

# HAPPINESS HAPPINESS INSTALLATION



## CAUTION

Parts are placed at the bottom of the product.

- If you have any questions with the product, please contact us by:
- **Email: [customerservice@zoy-living.com](mailto:customerservice@zoy-living.com)**  
(we will reply to you within 24 hours)

# Assembly Instructions







Model:CP6567EF11D

## CAUTION

**DO NOT** use any sharp objects to open plastic wrapped components as this may result damage to product or components .

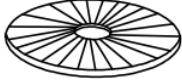
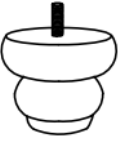
Your recliner comes packaged in **TWO** box. Carefully remove all of components from the packaging and setaside for assembly.

## Package Contents

<b>BOX 1</b> CP6567EF11D				
	A*1	B*1	C*4	D*2
<b>BOX 2</b> CP6567EF11D				
	E*2			
<b>BOX 2</b> CP6567EF11D				
	F*1	G*1		

# 1 RECLINER ASSEMBLY - BODY SETUP

## Step1

Install the combination of **wooden feet (D)** and **washers (C)** on the bottom of the **seat body (A)** facing the front of the sofa through the following methods.

Install the combination of **wooden feet (E)** and **washers (C)** on the bottom of the **seat body (A)** facing the back of the sofa.

Please tighten to secure the wooden legs and ensure they are securely installed before use.

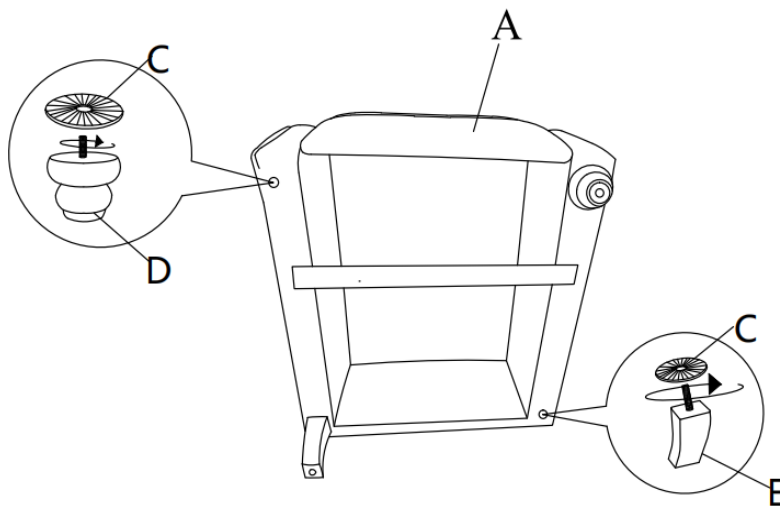

## Step2

Attach **Chair Back (B)** to **Chair Seat (A)** by aligning the metal grooves on **Chair Seat (A)** and **Chair Back (B)**.

Ensure the **Chair Back (B)** slides down to the bottom of the **Chair Seat (A)**'s metal grooves.

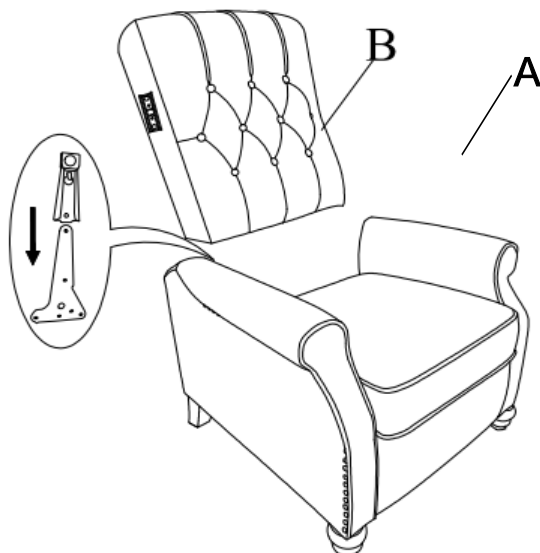

# 2 RECLINER ASSEMBLY - BODY SETUP

## Step3

Install both of chair Ears (F&G) by aligning the metal grooves and sliding down to the bottom.

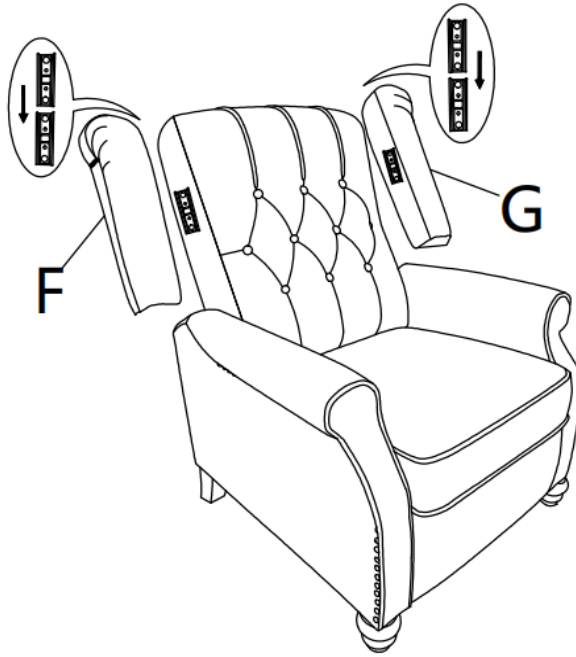

**ASSEMBLY COMPLETED**

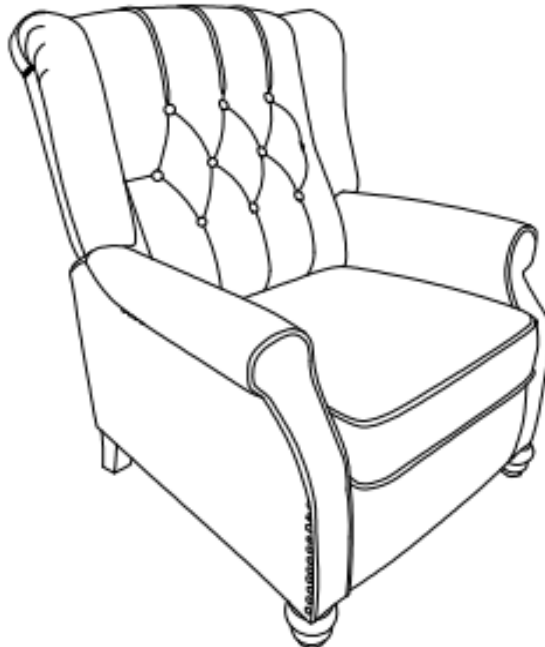

# 3 INSTRUCTIONS FOR USE - SIZE DIMENSIONS

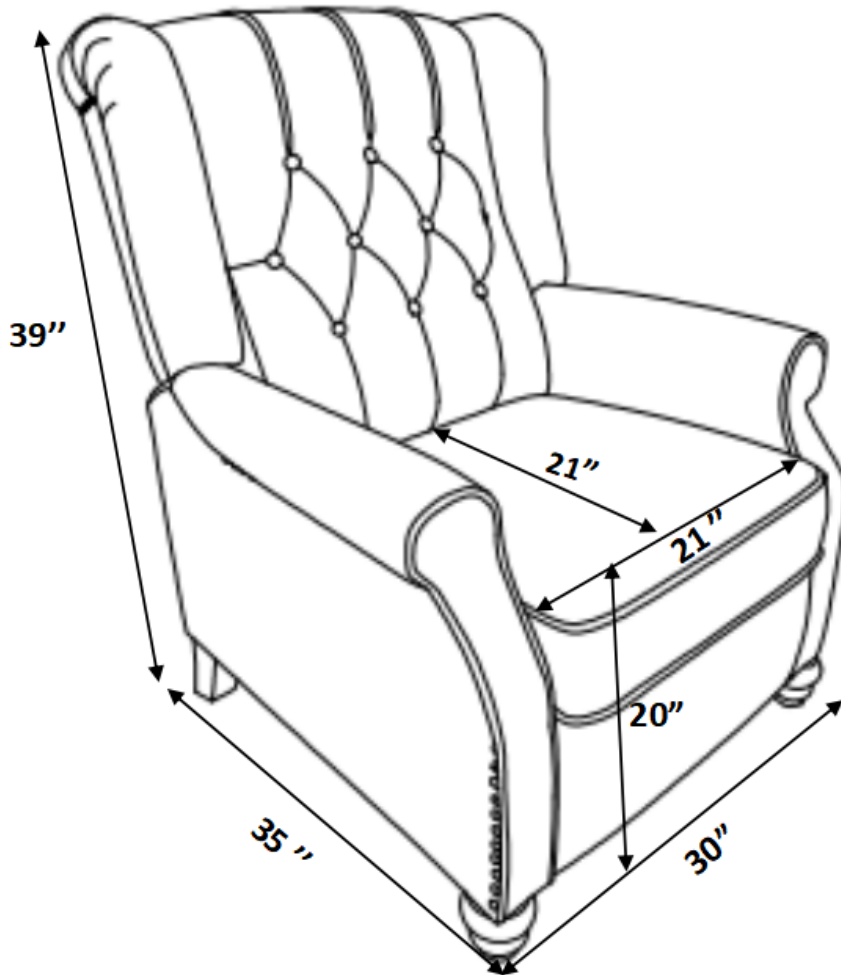

**ACCENT CHAIR**

**CP6567EF11D**

## ⚠️ WARNINGS

1. Please check if the components of the chair are all included and can be used normally.
2. Assemble all components according to the instruction correctly before you connect the chair to the power.
3. Please DO NOT sit on the armrests or footrest to eliminate the risk of tipping over.
4. If the chair is damaged or doesn't match the website description, please send clear pictures of the product and label of the carton to our service team for further help.
5. If the recliner doesn't work, you may try the following measures for self-checking firstly:
  - a) check if all the cables are connected;
  - b) check if the light of transformer is on.

If the chair still doesn't work, please feed the information back to our customer service in time and we will help you solve the matter as soon as possible.

6. If you have any questions about our products, please contact us by:

Email: [customerservice@zoy-living.com](mailto:customerservice@zoy-living.com) (we will respond to your inquiry within 24 hours)

