

# ASSEMBLY INSTRUCTIONS

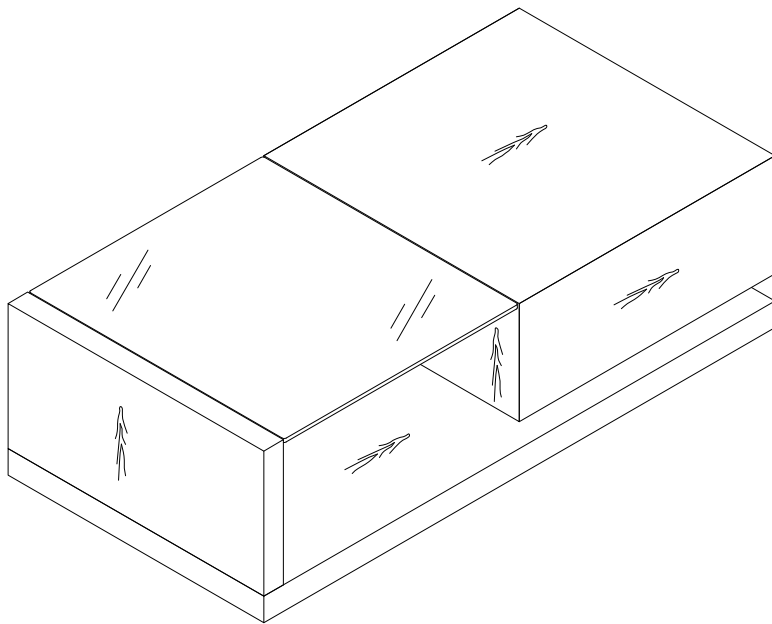

## TOOLS REQUIRED

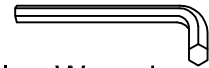

Allen Wrench

(Included)



Phillips Screwdriver

(Not Included)

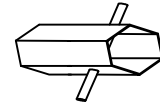

Socket Wrench

(Included)



2 - People  
Recommended

## ASSEMBLY RATING



EASY —————> DIFFICULT

The Assembly Rating is a 5-point system showing the level of effort needed to assemble a specific product.



## **CHECK BEFORE STARTING**

### **Are you missing anything?**

Double-check all parts, hardware and accessories listed are all accounted for.

### **Check out our Quick Tips!**

We recommend reviewing the pre-assembly handouts. Even experts need a refresher now and then!

### **Should we send any replacements?**

Are there any irregularities or flaws in the parts? We can send replacements!

### **Prep Time!**

Please review the assembly instructions and all diagrams prior to assembling.

# PRE ASSEMBLY INTRODUCTION

We understand building ready-to-assemble furniture can be a challenging experience for some. To help avoid confusion, we have provided some helpful tips that may speed up the process.



## Teamwork

ALWAYS have at least two people to help with transporting and assembling the product to avoid potential injury and/or damage.



## Suitable Location

Assembling near the area of the intended location is highly recommended.



## Sufficient Space

Make sure you have enough space to move around during the assembly.



## Avoid Scratches

Use cardboard, blankets or a carpeted area while assembling furniture to prevent to prevent scratches and damages.



## Flat Surface

Make sure the furniture rests on a flat and level surface with each leg evenly touching the floor.

# ASSEMBLY AND CARE ADVICE



**FAILURE TO FOLLOW THE GUIDELINES BELOW MAY RESULT IN INJURY AND/OR PROPERTY DAMAGE.**



Position each part correctly and insert screws or bolts into their respective holes.



Turn clockwise to tighten and only tighten when step is completed or when instructed to do so.



Use the appropriate hand tools or power tools for assembly. Select steps, such as tightening screws and/or bolts, may require hand tools to avoid causing damage during assembly.



Save the instructions and store any supplied tools for later maintenance.



After two weeks, check and tighten any loose hardware and repeat again every six months thereafter.

**IT IS THE USER'S RESPONSIBILITY TO MAINTAIN THE FURNITURE. THE HARDWARE MAY LOOSEN OVER TIME AND MAY CAUSE THE FURNITURE TO BE WOBBLY AND UNABLE TO SUPPORT ITS INTENDED WEIGHT CAPACITY. THIS MAY LEAD TO COLLAPSE AND MAY CAUSE SERIOUS INJURY.**

# COFFEE TABLE

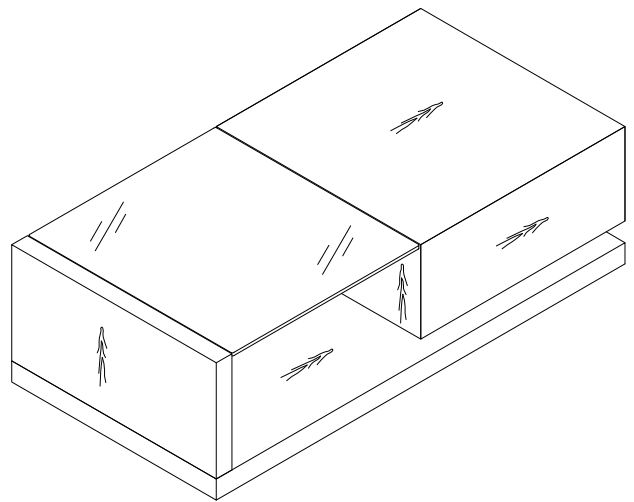
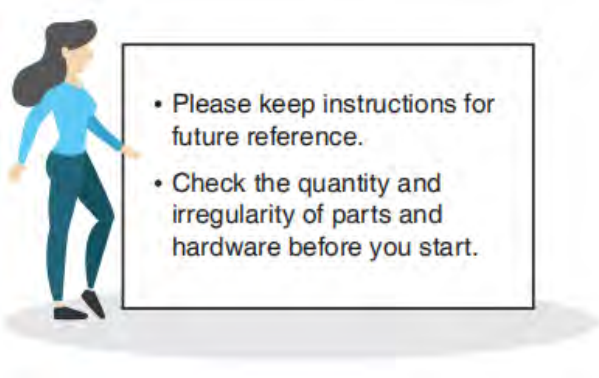

## PARTS

#1 1pc

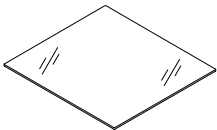

Glass

#2 1pc

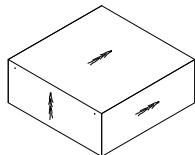

Box

#3 1pc

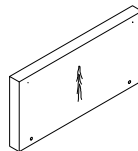

Left Upright Board

#4 1pc

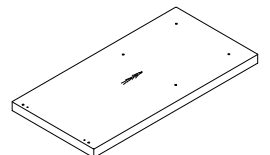

Bottom Board

#5 2pcs



Connection

# COFFEE TABLE

CM4568C



- Please keep instructions for future reference.
- Check the quantity and irregularity of parts and hardware before you start.

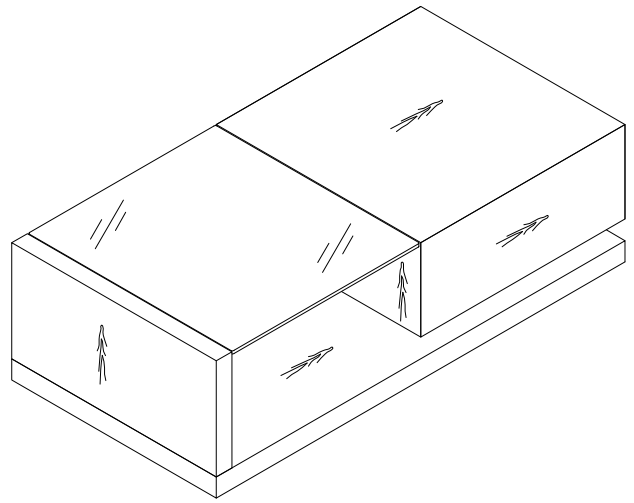

## HARDWARE

#A 4pcs



Bolt 1/4" x 1-3/8"

#B 2pcs



Rod 1/4" x 3-1/8"

#C 6pcs



Washer Ø16xØ7x1.0

#D 2pcs



Nut M6

#E 2pcs



Hammer Nut

#F 2pcs



Set Screw Ø6x30

#G 4pcs



Screw M5 x 15

#H 4pcs



Sucker

#I 6pcs



Adjustable Foot

#J 1pc

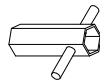

Socket Wrench M6

#K 2pcs



Ø20 Sealing Sticker

#L 1pc

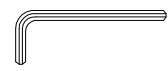

Allen Wrench M4

## CM4568C Points 2 cartons

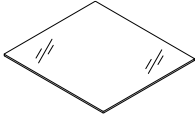
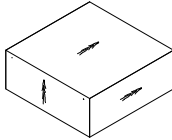
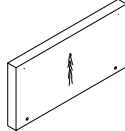
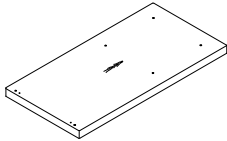
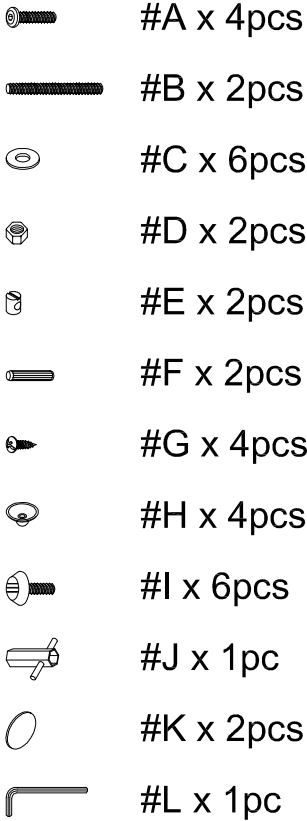
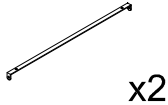
Carton	Designation		Part	Hardware
CM4568C-1	Glass	#1		
	Box	#2		
	Left Upright Board	#3		
CM4568C-2	Bottom Board	#4		
	Connection	#5		

# ASSEMBLY INSTRUCTIONS

1

Exploded View

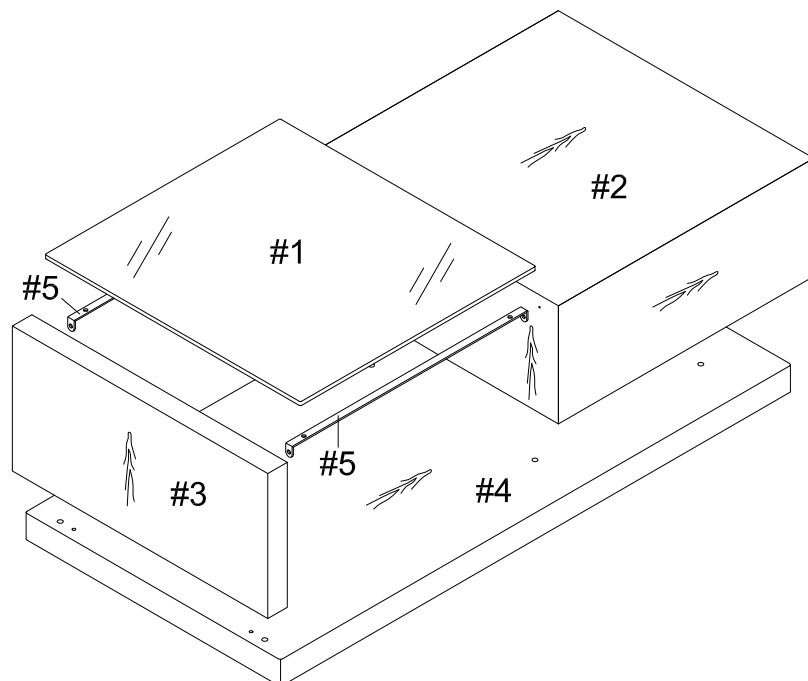

2

- Part #2 x 1pc
- Part #4 x 1pc
- Hardware #A x 4pcs
- Hardware #C x 4pcs
- Hardware #I x 6pcs
- Hardware #L x 1pc

Align box (#2) to the bottom board (#4), then secure by using bolts (#A) with washers (#C). Attach levelers (#I) onto the bottom board (#4).

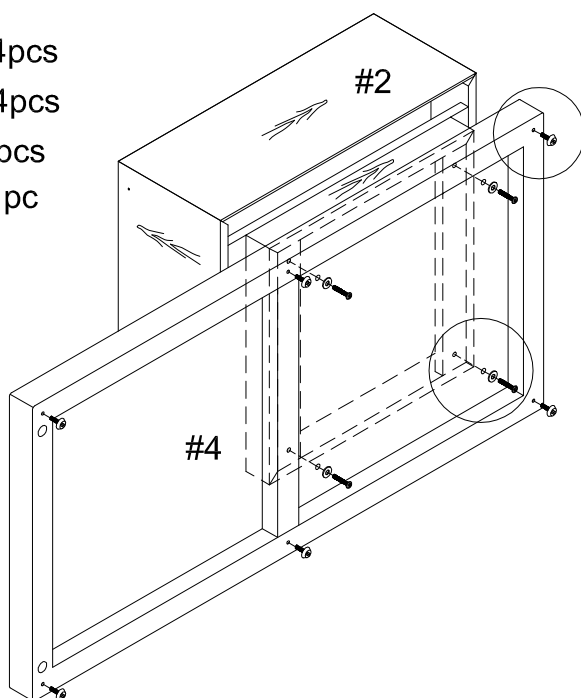

2-1

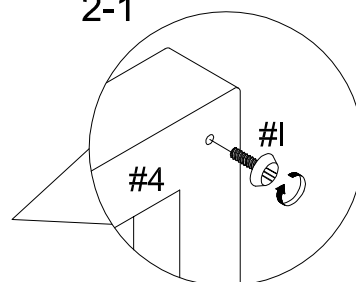

2-2

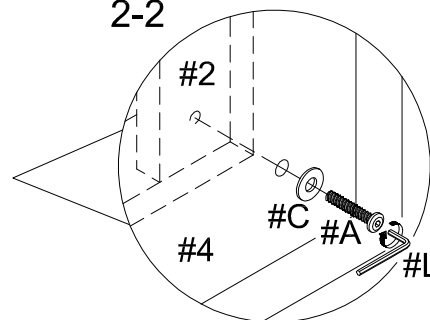

# ASSEMBLY INSTRUCTIONS

Connect threaded bolts (#B) to barrel nuts (#E) through the upright board (#3). Attach dowels (#F) onto the upright board (#3).

## 3

- Part #3 x 1pc
- Hardware #B x 2pcs
- Hardware #C x 2pcs
- Hardware #D x 2pcs
- Hardware #E x 2pcs
- Hardware #F x 2pcs
- Hardware #J x 1pc

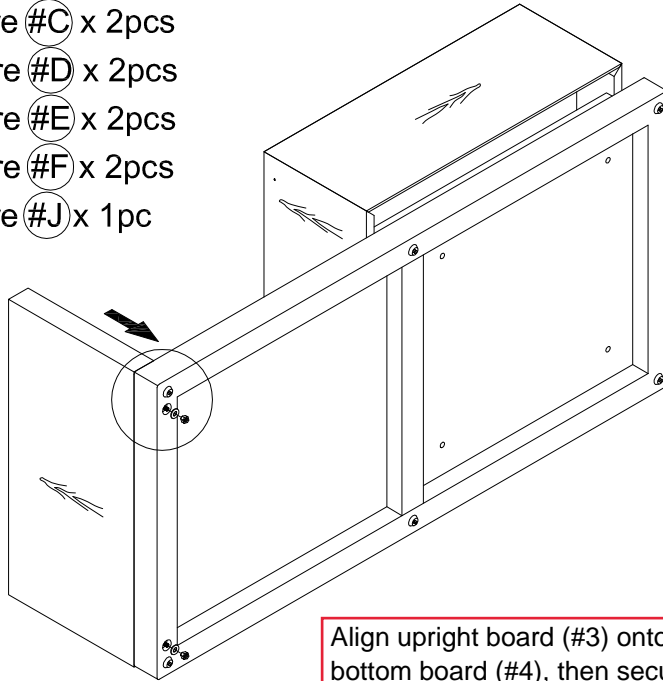

Align upright board (#3) onto bottom board (#4), then secure by using nuts (#D) with washers (#C).

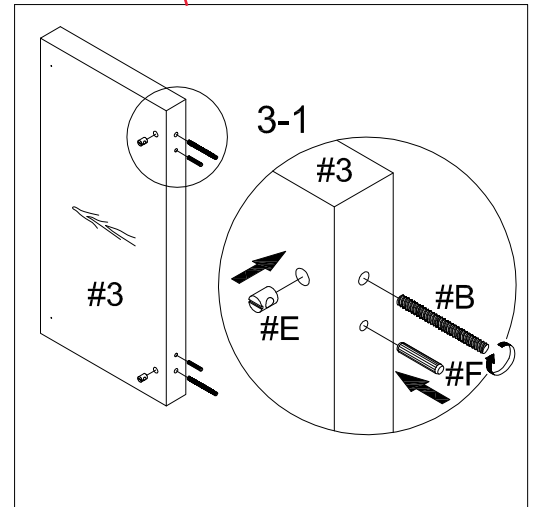

3-2

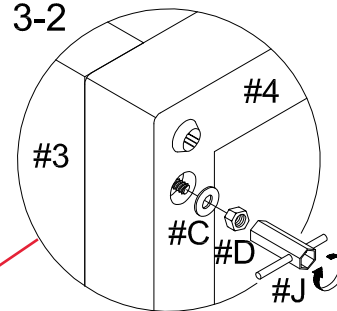

## 4

- Part #5 x 2pcs
- Hardware #G x 4pcs
- Hardware #K x 2pcs

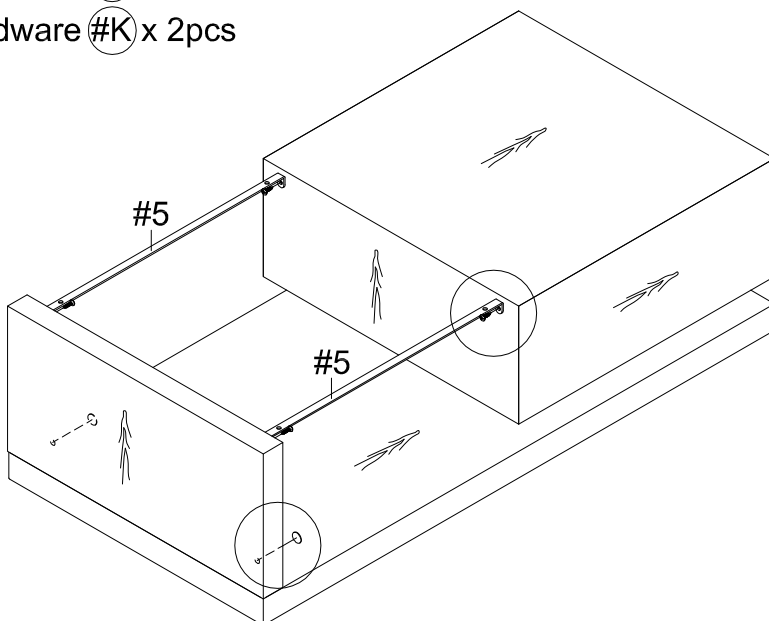

Align connections (#5) to the frame, then secure by using screws (#G).

4-1

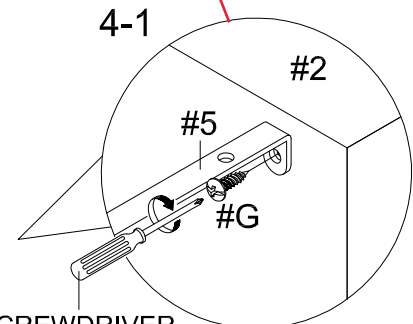

SCREWDRIVER  
(NOT PROVIDED)

4-2

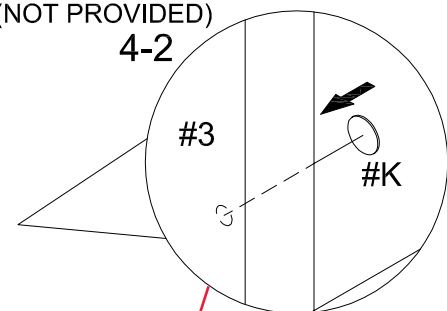

Cover barrel nuts by using stickers (#K).

# ASSEMBLY INSTRUCTIONS

## 5

Part #1 x 1pc  
Hardware #H x 4pcs

Attach suckers (#H) to the connections (#5), then place glass (#1) onto the top.

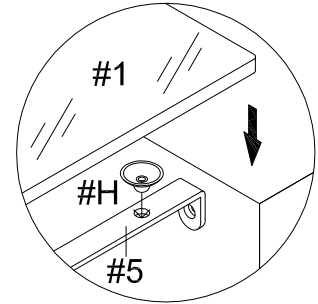
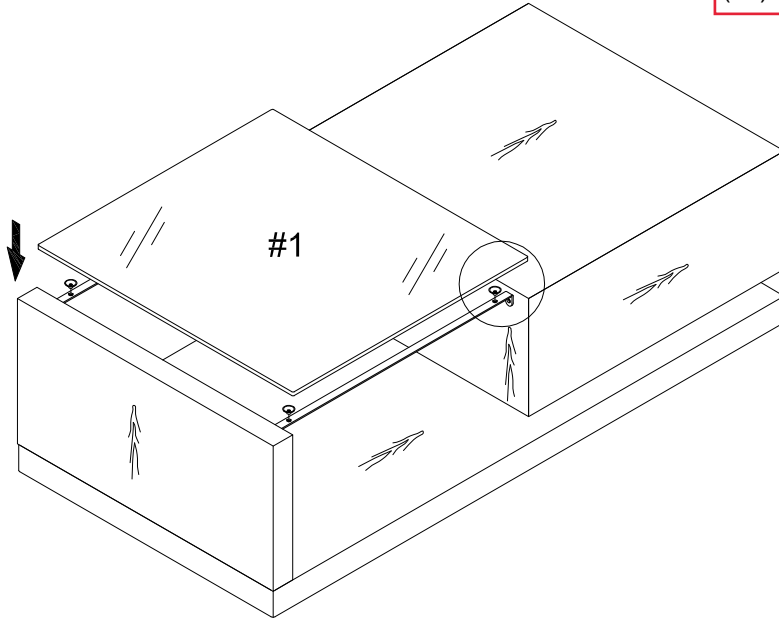

## 6

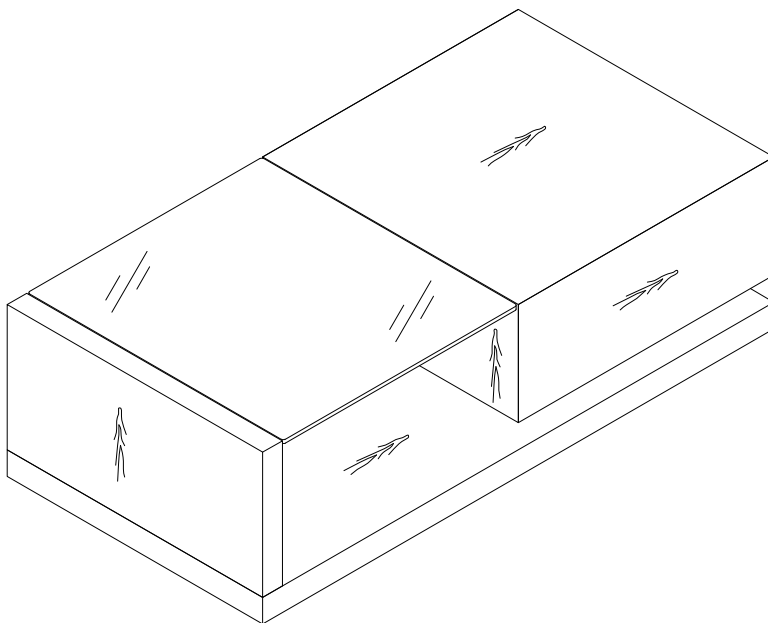

### ASSEMBLY COMPLETED



Please ensure the furniture rests on an even and flat surface. If the product wobbles or feels loose, double-check all bolts and/or screws are properly tightened and secured.



#### Keep this handy!

Please retain this instruction manual and any order-related information for future reference.



#### Lift, don't drag!

To avoid damage to product please always LIFT the product when transporting or adjusting the placement.

# ASSEMBLY INSTRUCTIONS

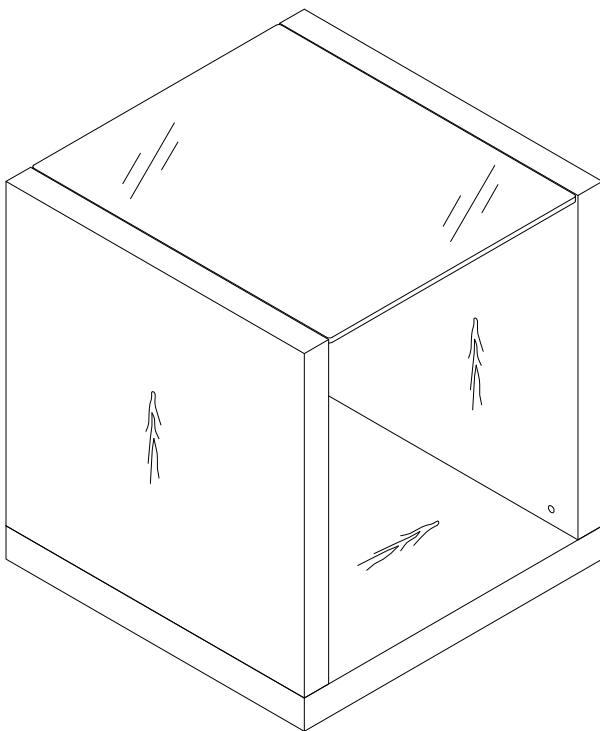

## TOOLS REQUIRED



Phillips Screwdriver

(Not Included)

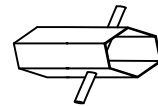

Socket Wrench

(Included)



2 - People  
Recommended

## ASSEMBLY RATING



EASY —————> DIFFICULT

The Assembly Rating is a 5-point system showing the level of effort needed to assemble a specific product.



## **CHECK BEFORE STARTING**

### **Are you missing anything?**

Double-check all parts, hardware and accessories listed are all accounted for.

### **Check out our Quick Tips!**

We recommend reviewing the pre-assembly handouts. Even experts need a refresher now and then!

### **Should we send any replacements?**

Are there any irregularities or flaws in the parts? We can send replacements!

### **Prep Time!**

Please review the assembly instructions and all diagrams prior to assembling.

# PRE ASSEMBLY INTRODUCTION

We understand building ready-to-assemble furniture can be a challenging experience for some. To help avoid confusion, we have provided some helpful tips that may speed up the process.

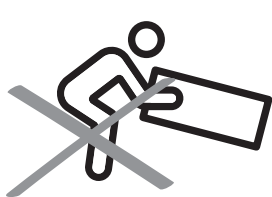

## Teamwork

ALWAYS have at least two people to help with transporting and assembling the product to avoid potential injury and/or damage.

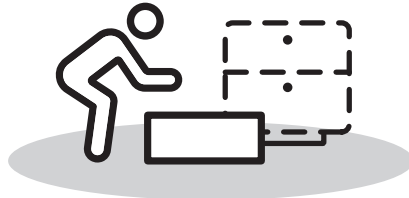
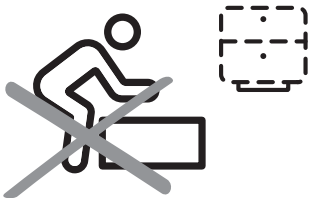

## Suitable Location

Assembling near the area of the intended location is highly recommended.



## Sufficient Space

Make sure you have enough space to move around during the assembly.



## Avoid Scratches

Use cardboard, blankets or a carpeted area while assembling furniture to prevent to prevent scratches and damages.

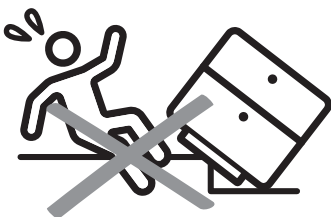

## Flat Surface

Make sure the furniture rests on a flat and level surface with each leg evenly touching the floor.

# ASSEMBLY AND CARE ADVICE



**FAILURE TO FOLLOW THE GUIDELINES BELOW MAY RESULT IN INJURY AND/OR PROPERTY DAMAGE.**



Position each part correctly and insert screws or bolts into their respective holes.

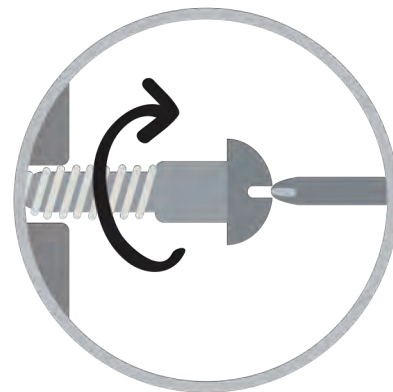

Turn clockwise to tighten and only tighten when step is completed or when instructed to do so.



Use the appropriate hand tools or power tools for assembly. Select steps, such as tightening screws and/or bolts, may require hand tools to avoid causing damage during assembly.

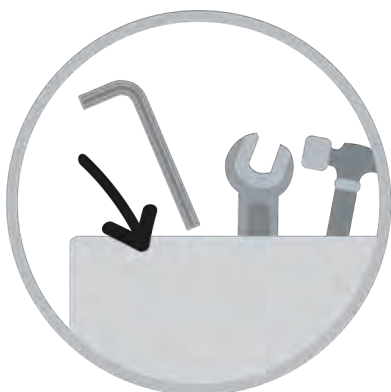

Save the instructions and store any supplied tools for later maintenance.

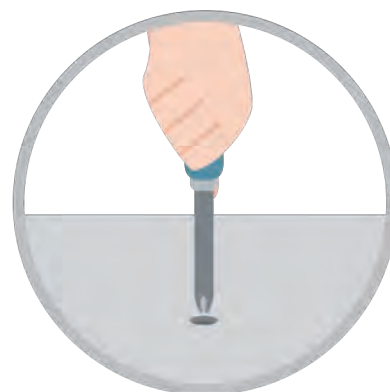

After two weeks, check and tighten any loose hardware and repeat again every six months thereafter.

**IT IS THE USER'S RESPONSIBILITY TO MAINTAIN THE FURNITURE. THE HARDWARE MAY LOOSEN OVER TIME AND MAY CAUSE THE FURNITURE TO BE WOBBLY AND UNABLE TO SUPPORT ITS INTENDED WEIGHT CAPACITY. THIS MAY LEAD TO COLLAPSE AND MAY CAUSE SERIOUS INJURY.**

# END TABLE



- Please keep instructions for future reference.
- Check the quantity and irregularity of parts and hardware before you start.

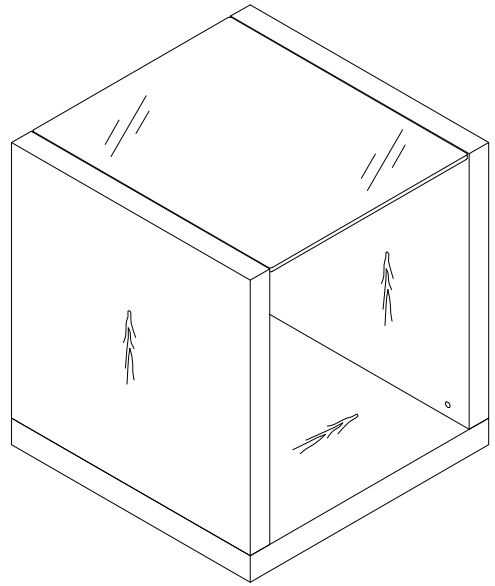

## PARTS

#1 1pc

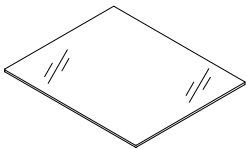

Glass

#2 2pcs

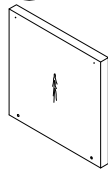

Upright Board

#3 1pc

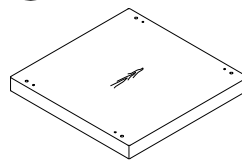

Bottom Board

#4 2pcs



Connection

## HARDWARE

#A 4pcs



Ø20 Sealing Stickers

#B 4pcs



Rod 1/4" x 3-1/8"

#C 4pcs



Washer Ø16xØ7x1.0

#D 4pcs



Nut M6

#E 4pcs



Hammer Nut

#F 4pcs



Set Screw Ø6x30

#G 4pcs



Screw M5 x 15

#H 4pcs



Sucker

#I 4pcs



Adjustable Foot

#J 1pc

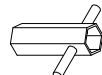

Socket Wrench M6

# ASSEMBLY INSTRUCTIONS

1

Exploded View

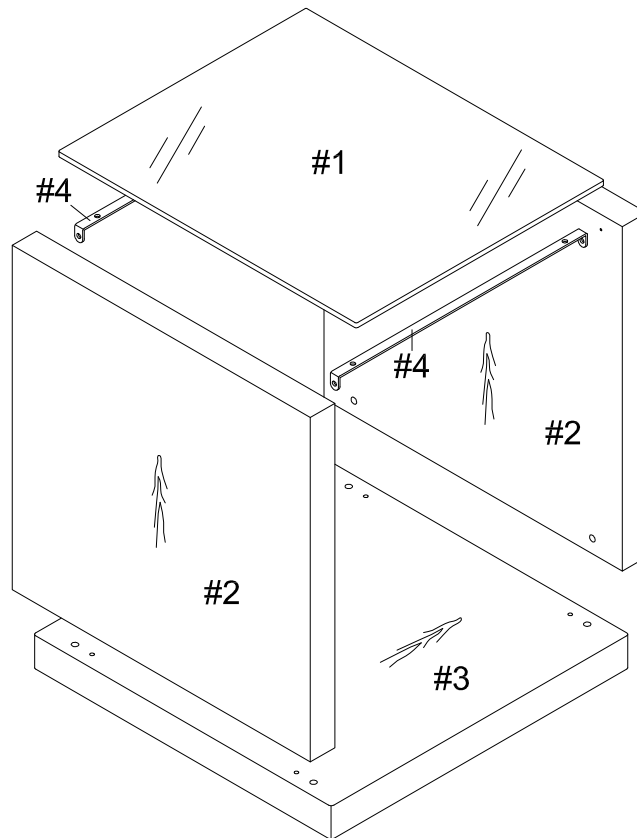

2

- Part #2 x 2pcs
- Hardware #B x 4pcs
- Hardware #E x 4pcs
- Hardware #F x 4pcs

Connect threaded bolts (#B) to barrel nuts (#E) through the upright board (#2). Attach dowels (#F) onto the upright board (#2).

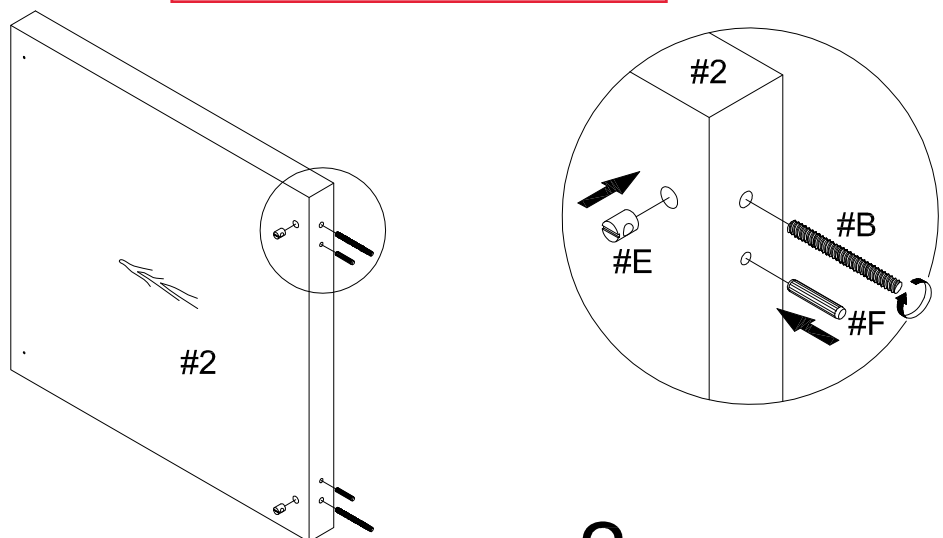

x2

# ASSEMBLY INSTRUCTIONS

## 3

- Part #3 x 1pc
- Hardware #C x 4pcs
- Hardware #D x 4pcs
- Hardware #I x 4pcs
- Hardware #J x 1pc

Align upright boards (#2) to the bottom board (#3), then secure by using nuts (#D) with washers (#C). Attach levelers (#I) to the bottom board (#3).

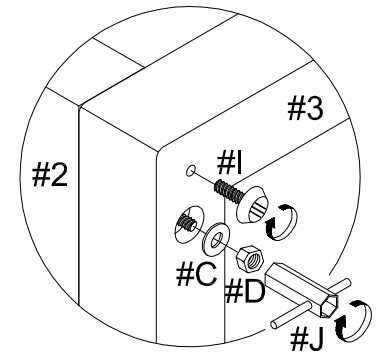
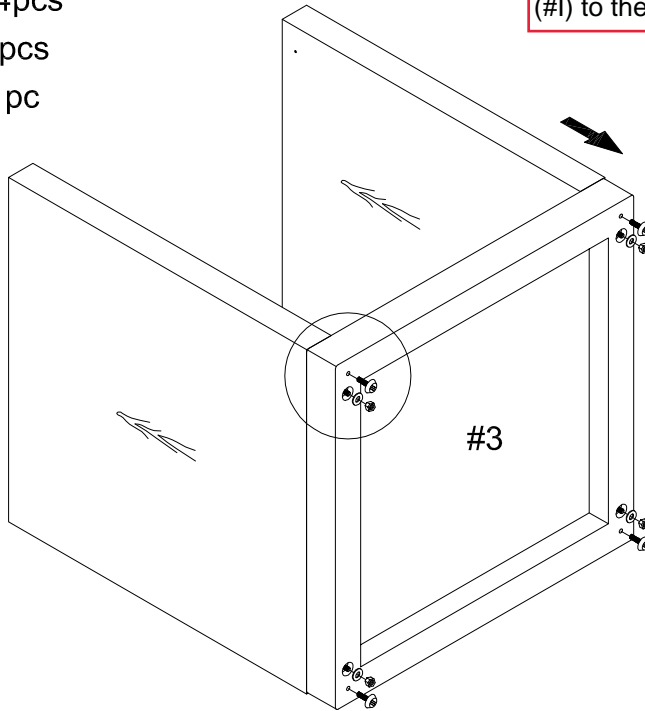

## 4

- Part #4 x 2pcs
- Hardware #A x 4pcs
- Hardware #G x 4pcs

Align connections (#4) to the upright boards (#2), then secure by using screws (#G). Cover barrel nuts by using stickers (#A).

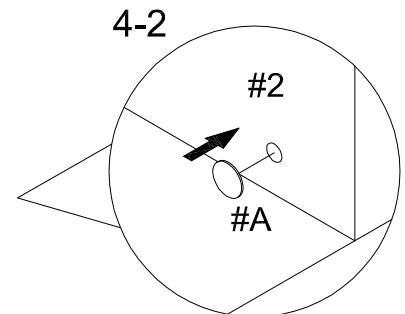
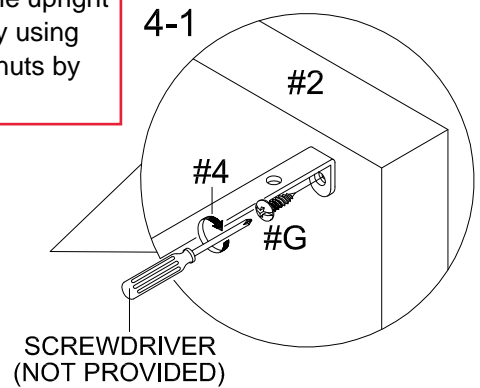
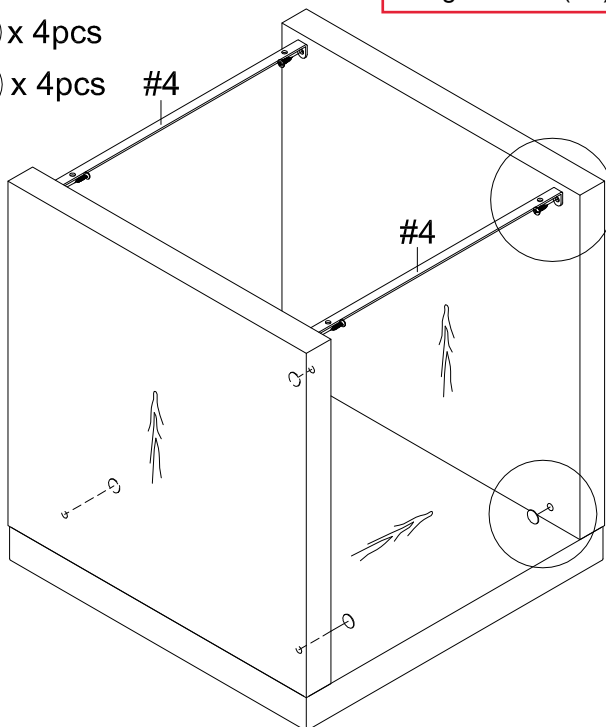

# ASSEMBLY INSTRUCTIONS

## 5

Part #1 x 1pc  
Hardware #H x 4pcs

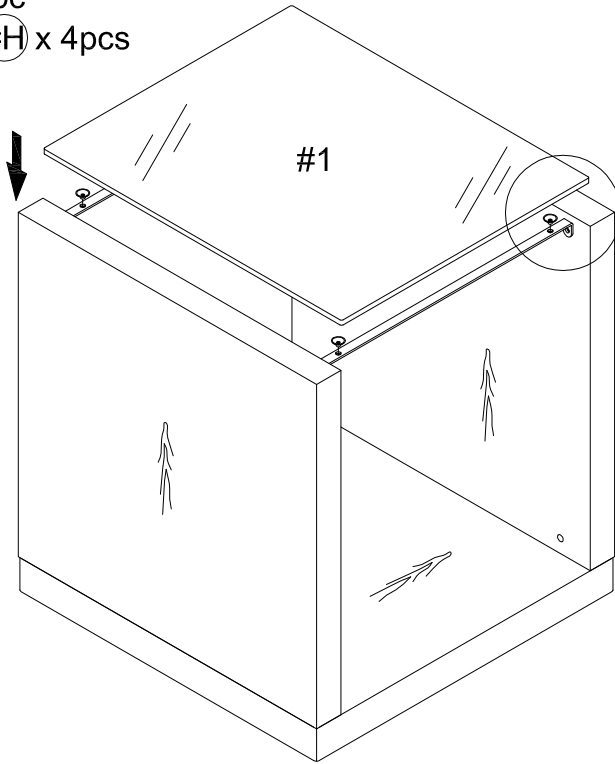

Attach suckers (#H) onto connections (#4), then carefully place glass (#1) onto the top.

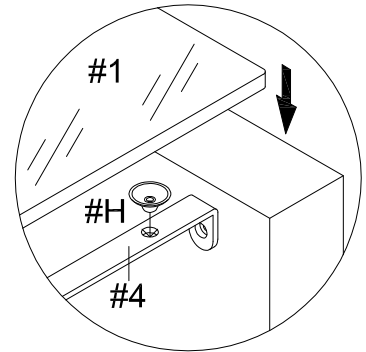

## 6

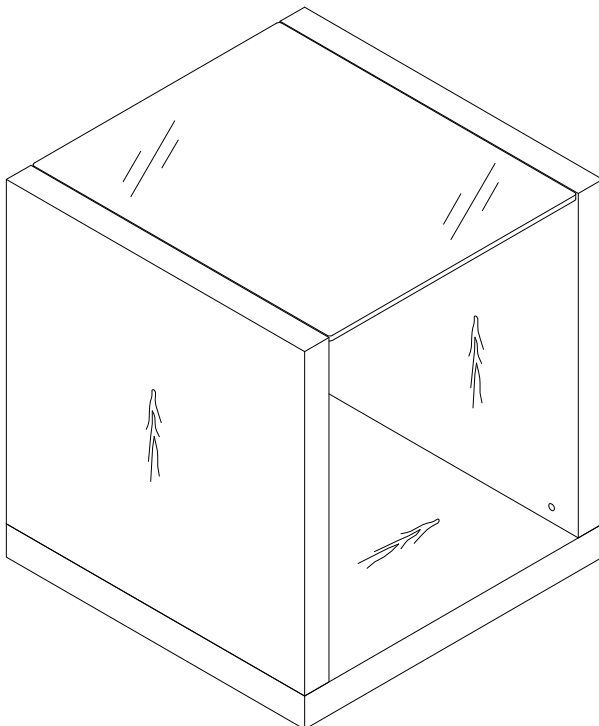

### ASSEMBLY COMPLETED



Please ensure the furniture rests on an even and flat surface. If the product wobbles or feels loose, double-check all bolts and/or screws are properly tightened and secured.



#### Keep this handy!

Please retain this instruction manual and any order-related information for future reference.



#### Lift, don't drag!

To avoid damage to product please always LIFT the product when transporting or adjusting the placement.

# ASSEMBLY INSTRUCTIONS

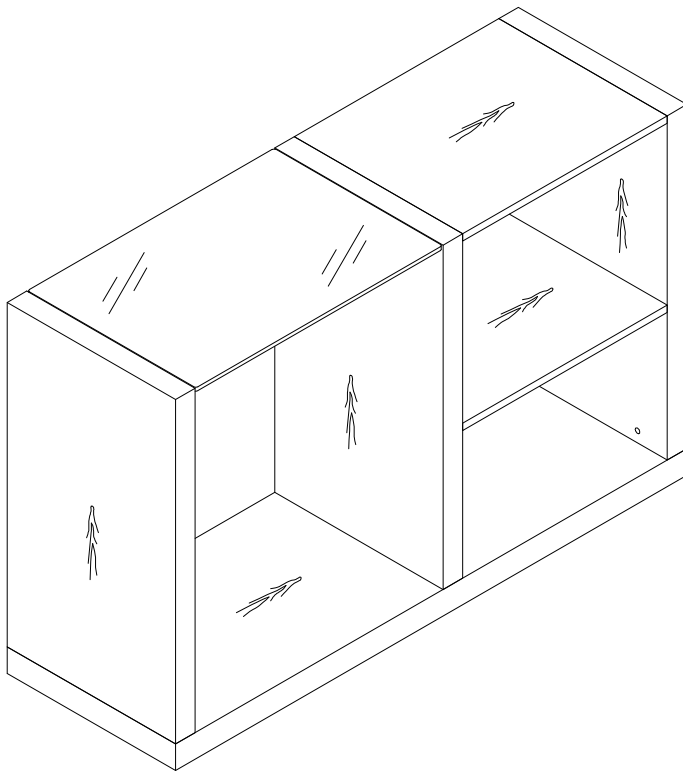

## TOOLS REQUIRED



Phillips Screwdriver

(Not Included)

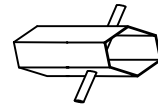

Socket Wrench

(Included)



2 - People  
Recommended

## ASSEMBLY RATING



EASY —————> DIFFICULT

The Assembly Rating is a 5-point system showing the level of effort needed to assemble a specific product.



## **CHECK BEFORE STARTING**

### **Are you missing anything?**

Double-check all parts, hardware and accessories listed are all accounted for.

### **Check out our Quick Tips!**

We recommend reviewing the pre-assembly handouts. Even experts need a refresher now and then!

### **Should we send any replacements?**

Are there any irregularities or flaws in the parts? We can send replacements!

### **Prep Time!**

Please review the assembly instructions and all diagrams prior to assembling.

# PRE ASSEMBLY INTRODUCTION

We understand building ready-to-assemble furniture can be a challenging experience for some. To help avoid confusion, we have provided some helpful tips that may speed up the process.

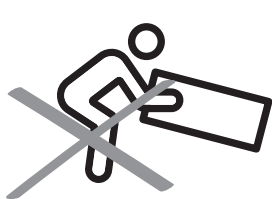

## Teamwork

ALWAYS have at least two people to help with transporting and assembling the product to avoid potential injury and/or damage.

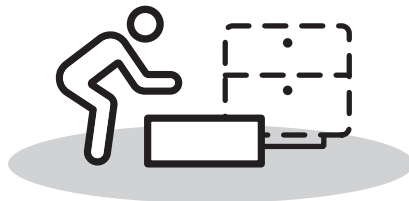
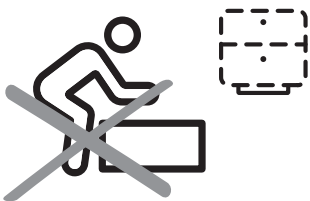

## Suitable Location

Assembling near the area of the intended location is highly recommended.



## Sufficient Space

Make sure you have enough space to move around during the assembly.

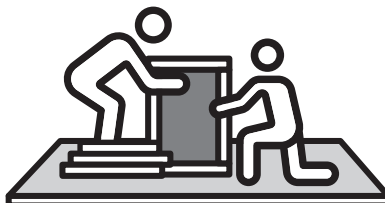

## Avoid Scratches

Use cardboard, blankets or a carpeted area while assembling furniture to prevent to prevent scratches and damages.

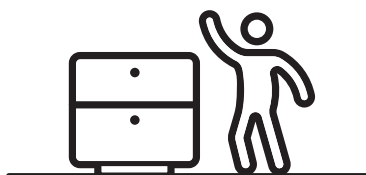
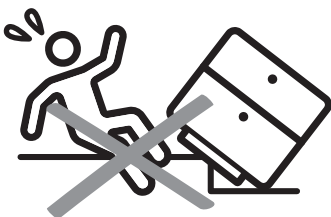

## Flat Surface

Make sure the furniture rests on a flat and level surface with each leg evenly touching the floor.

# ASSEMBLY AND CARE ADVICE



**FAILURE TO FOLLOW THE GUIDELINES BELOW MAY RESULT IN INJURY AND/OR PROPERTY DAMAGE.**



Position each part correctly and insert screws or bolts into their respective holes.

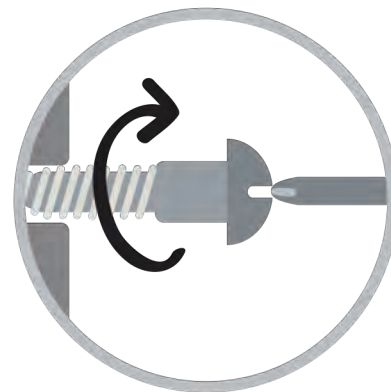

Turn clockwise to tighten and only tighten when step is completed or when instructed to do so.



Use the appropriate hand tools or power tools for assembly. Select steps, such as tightening screws and/or bolts, may require hand tools to avoid causing damage during assembly.



Save the instructions and store any supplied tools for later maintenance.

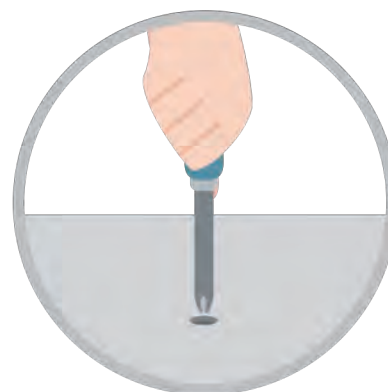

After two weeks, check and tighten any loose hardware and repeat again every six months thereafter.

**IT IS THE USER'S RESPONSIBILITY TO MAINTAIN THE FURNITURE. THE HARDWARE MAY LOOSEN OVER TIME AND MAY CAUSE THE FURNITURE TO BE WOBBLY AND UNABLE TO SUPPORT ITS INTENDED WEIGHT CAPACITY. THIS MAY LEAD TO COLLAPSE AND MAY CAUSE SERIOUS INJURY.**

# CAM LOCK FASTENER ASSEMBLY INSTRUCTIONS

## Note :

Every cam lock bolt must have a cam lock connector in order to fasten the parts together.

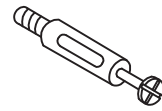

cam bolt



cam lock

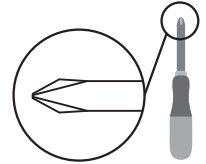

screwdriver

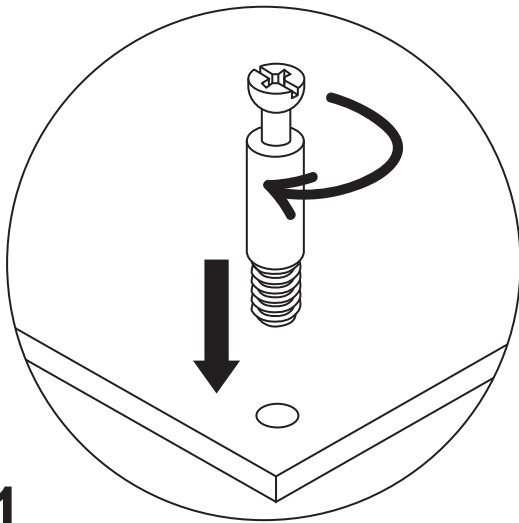

**1**

Screw the cam bolt into panel.

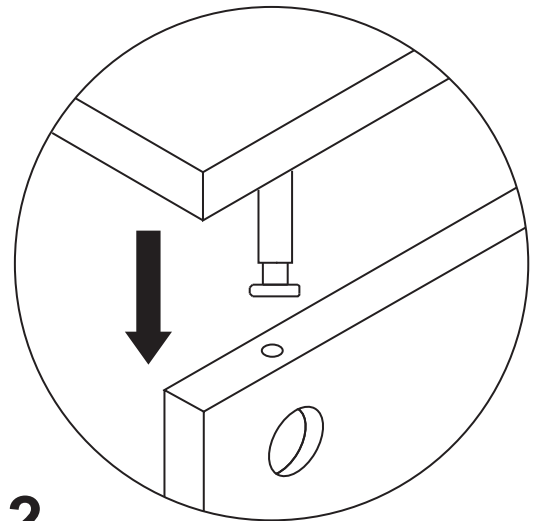

**2**

Insert the cam bolt into the bolt hole of joint panel.

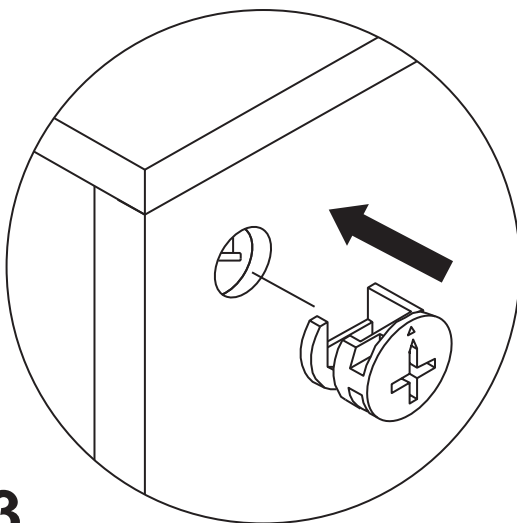

**3**

Align the cam lock with its side opening (or arrow) pointing to cam bolt.

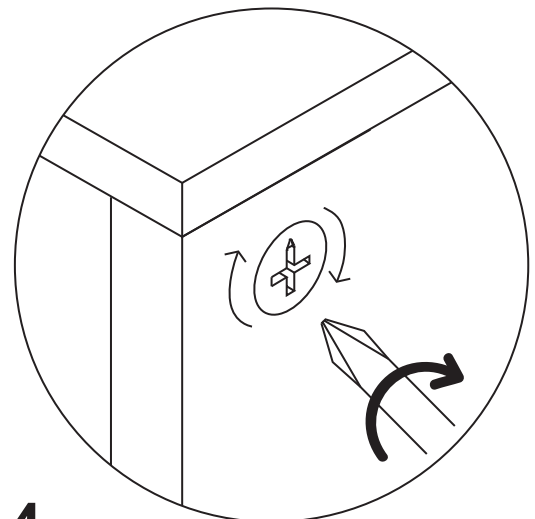

**4**

Turn the cam lock clockwise gently until it will not turn any more.

# SOFA TABLE

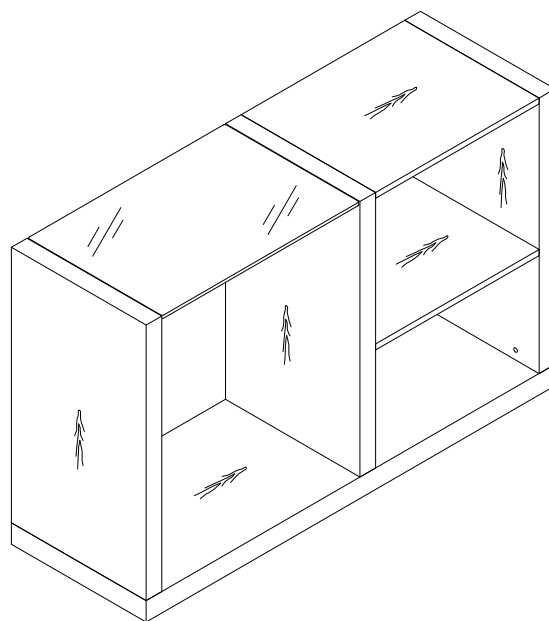
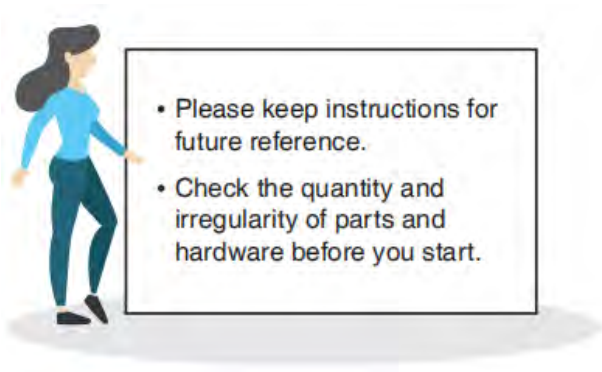

## PARTS

#1 1pc

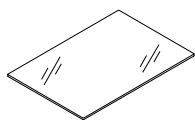

Glass

#2 1pc

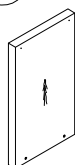

Left upright board

#3 1pc

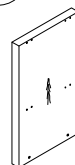

Middle upright board

#4 1pc



Right upright board

#5 1pc

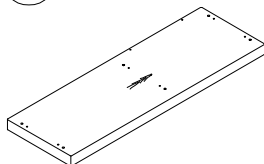

Bottom board

#6 1pc

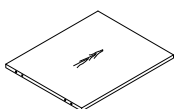

Up board

#7 1pc

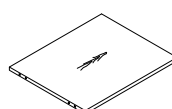

Middle board

#8 1pc

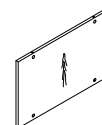

Back board

#9 2pcs



Connection

# SOFA TABLE

CM4568S



- Please keep instructions for future reference.
- Check the quantity and irregularity of parts and hardware before you start.

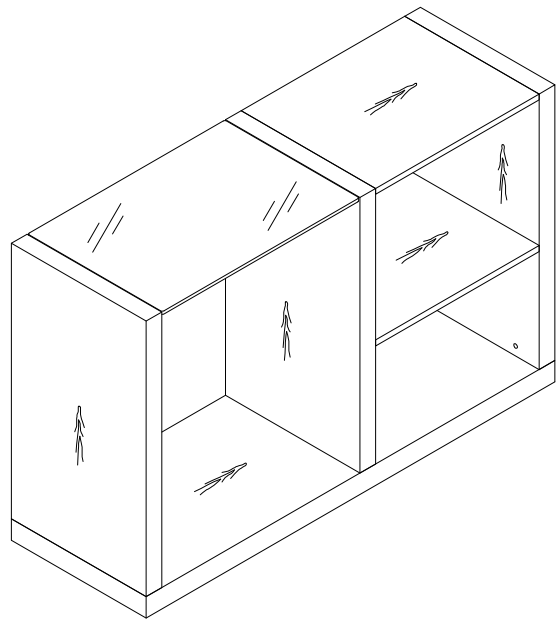

## HARDWARE

#A 2pcs



Rod 1/4" x 2-1/8"

#B 4pcs



Rod 1/4" x 3-1/8"

#C 6pcs



Washer Ø16xØ7x1.0

#D 6pcs



Nut M6

#E 6pcs



Hammer Nut

#F 14pcs



Set Screw Ø6x30

#G 4pcs



Screw M5 x 15

#H 4pcs



Sucker

#I 6pcs



Adjustable Foot

#J 1pc



Socket Wrench M6

#K 8pcs



Ø20 Sealing sticker

#L 8pcs

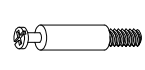

Cam Bolt M6x40

#M 8pcs



Cam Lock Ø14.5x11

#N 4pcs



Cam Bolt M6x24

#O 4pcs



Cam Lock Ø12x10.5

# ASSEMBLY INSTRUCTIONS

1

## Exploded View

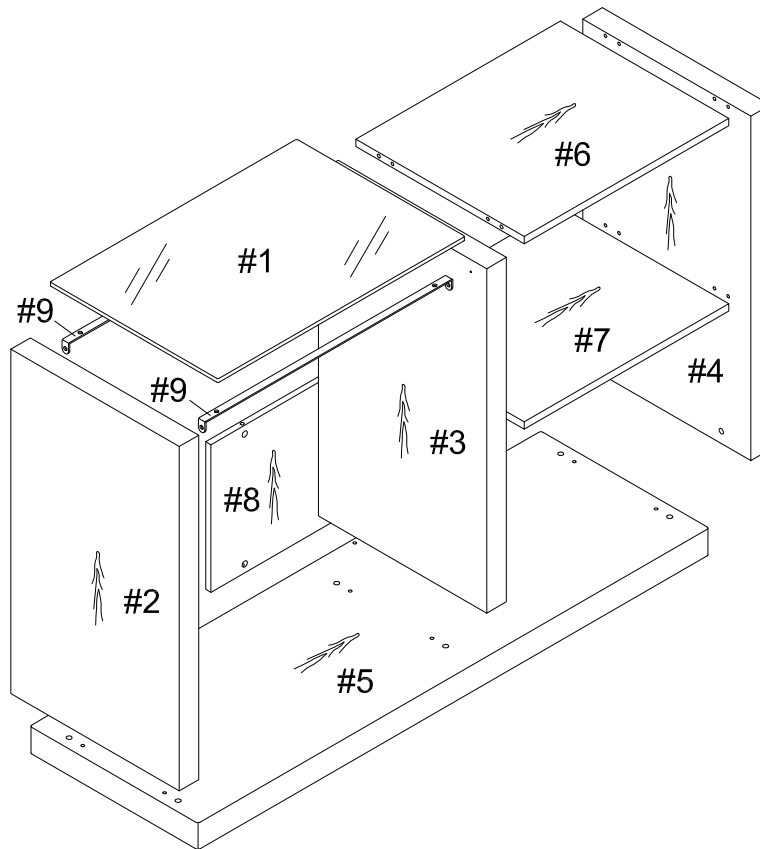

2

- Part #3 x 1pc
- Part #4 x 1pc
- Part #6 x 1pc
- Part #7 x 1pc
- Hardware #F x 8pcs
- Hardware #L x 8pcs
- Hardware #M x 8pcs

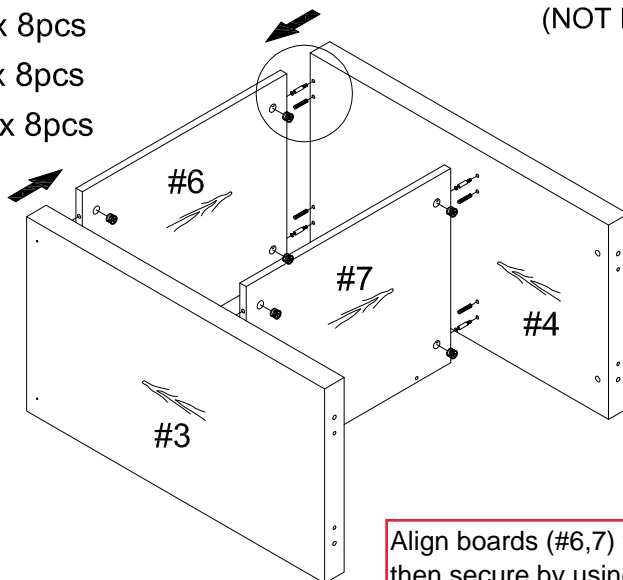

Attach cam bolts (#L) and dowels (#F) onto boards (#2,3).

2-1

SCREWDRIVER  
(NOT PROVIDED)

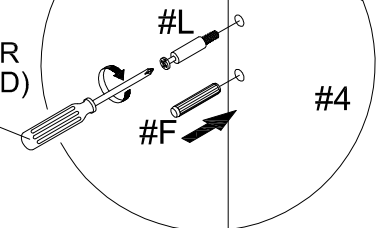

2-2

Align boards (#6,7) to the boards (#3,4), then secure by using cam locks (#M).

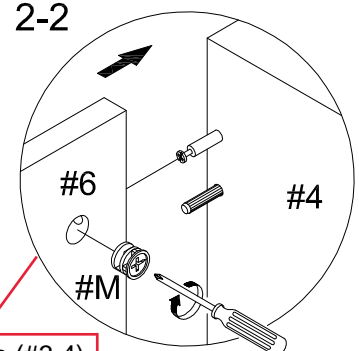

# ASSEMBLY INSTRUCTIONS

## 3

- Part #8 x 1pc
- Hardware #N x 2pcs
- Hardware #O x 2pcs

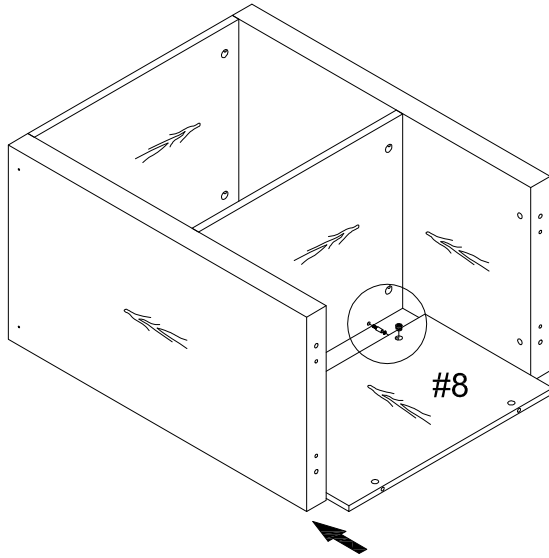

Attach cam bolts (#N) onto board (#7).

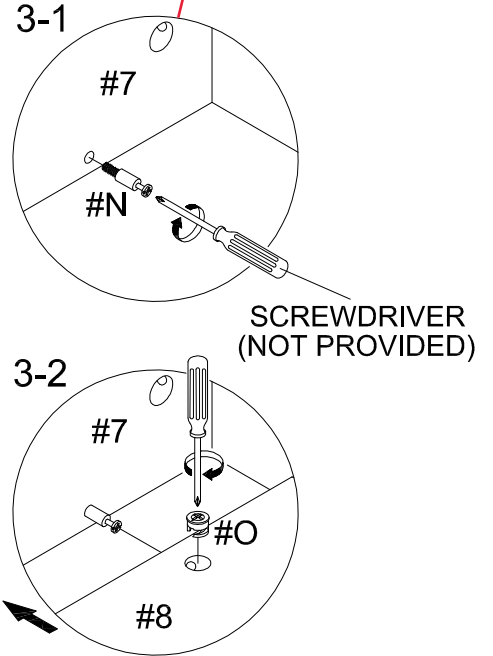

Align board (#8) to the board (#7), then secure by using cam locks (#O).

## 4

- Part #2 x 1pc
- Hardware #A x 2pcs
- Hardware #B x 4pcs
- Hardware #E x 6pcs
- Hardware #F x 6pcs

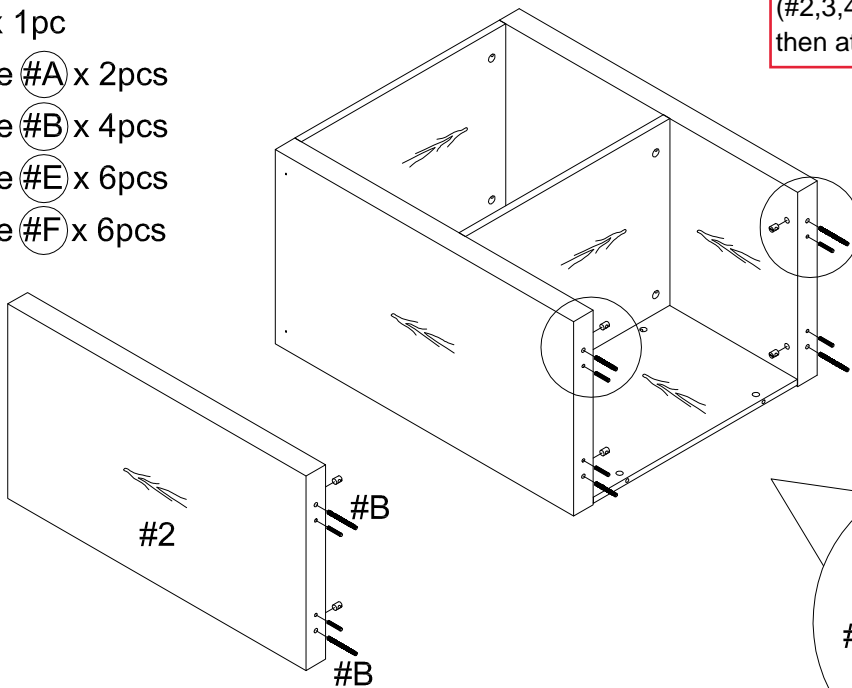

Attach threaded bolts (#A,B) to the barrel nuts (#E) onto boards (#2,3,4) as shown in the diagram, then attach dowels (#F).

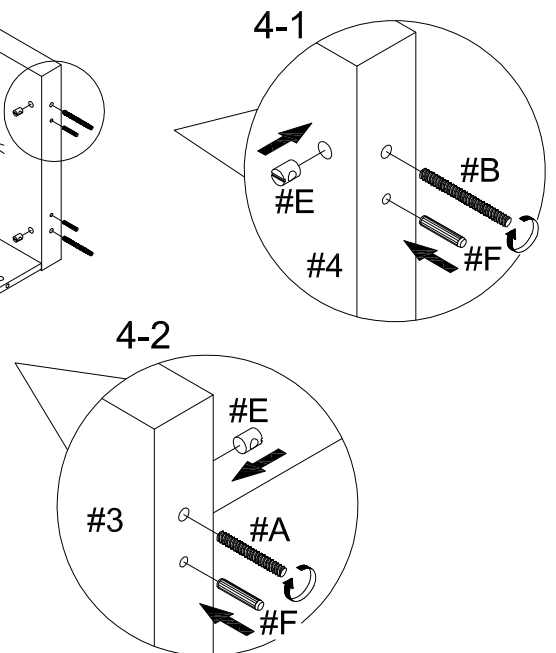

# ASSEMBLY INSTRUCTIONS

## 5

Attach cam bolts (#N) onto board (#5), then align board (#5) to the unit. Secure cam bolts (#N) by using cam locks (#O). Secure threaded bolts by using nuts (#D) with washers (#C). Attach levelers (#I) onto the board (#5).

Part #5 x 1pc

Hardware #C x 6pcs

Hardware #D x 6pcs

Hardware #I x 6pcs

Hardware #J x 1pc

Hardware #N x 2pcs

Hardware #O x 2pcs

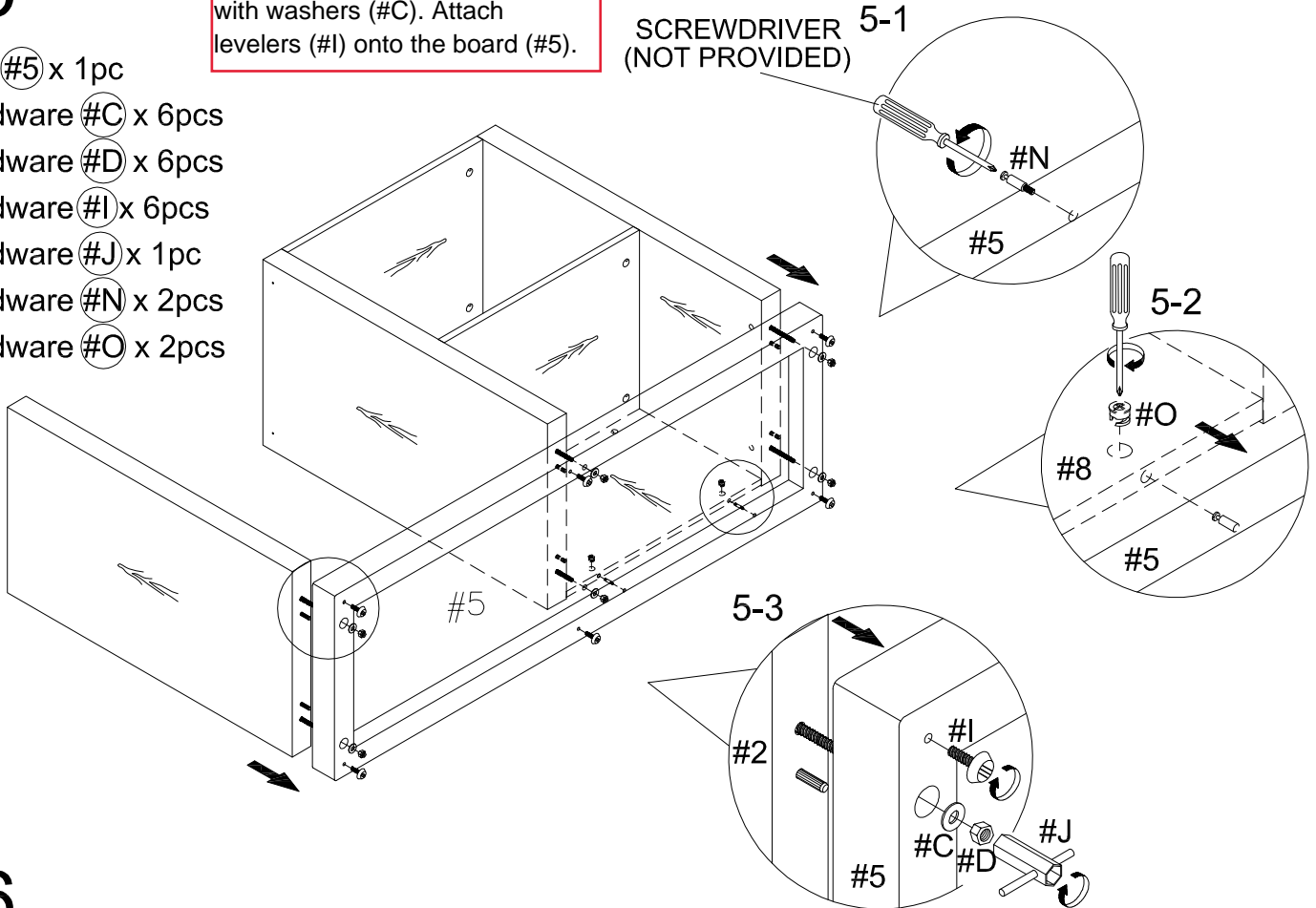

## 6

Part #9 x 2pcs

Hardware #G x 4pcs

Hardware #K x 8pcs

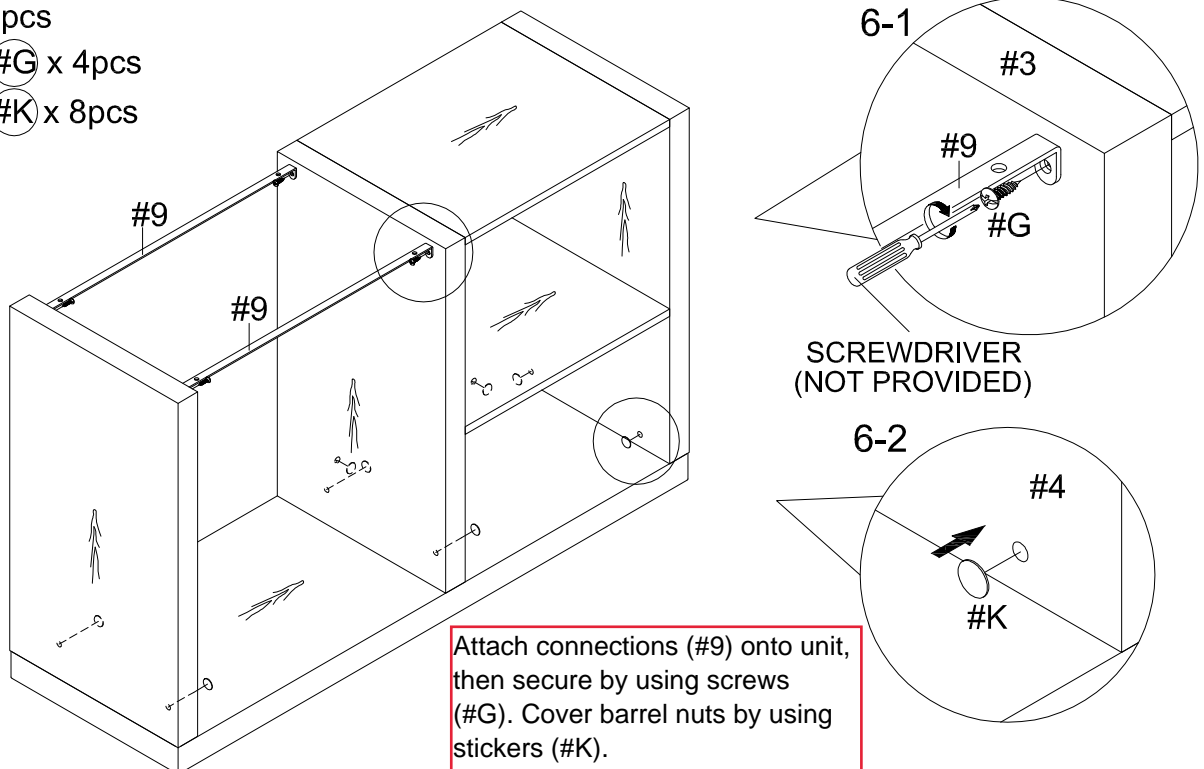

Attach connections (#9) onto unit, then secure by using screws (#G). Cover barrel nuts by using stickers (#K).

# ASSEMBLY INSTRUCTIONS

## 7

Part #1 x 1pc  
Hardware #H x 4pcs

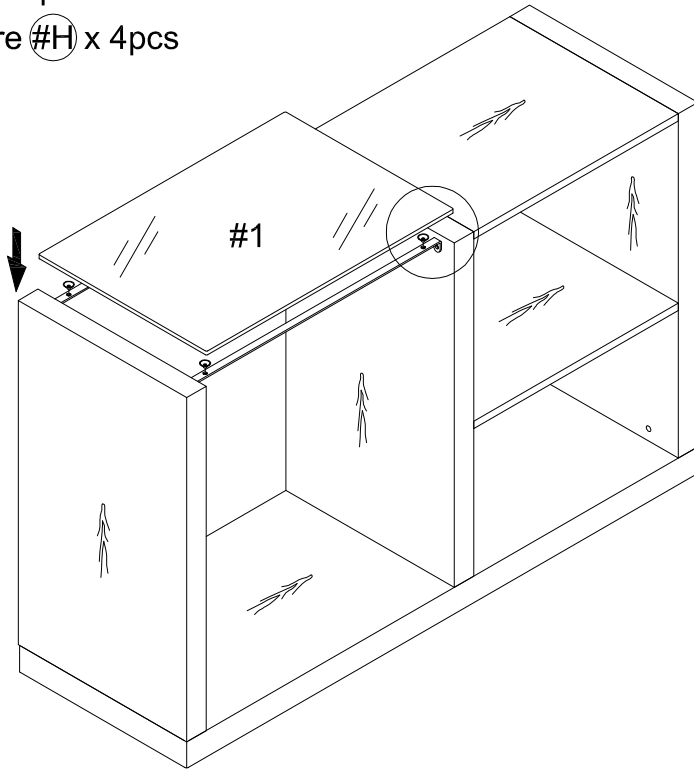

Attach suckers (#H) onto connections (#9), then place glass (#1) onto the top.

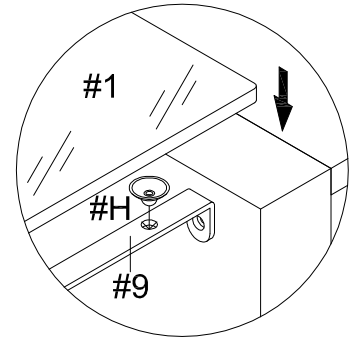

## 8

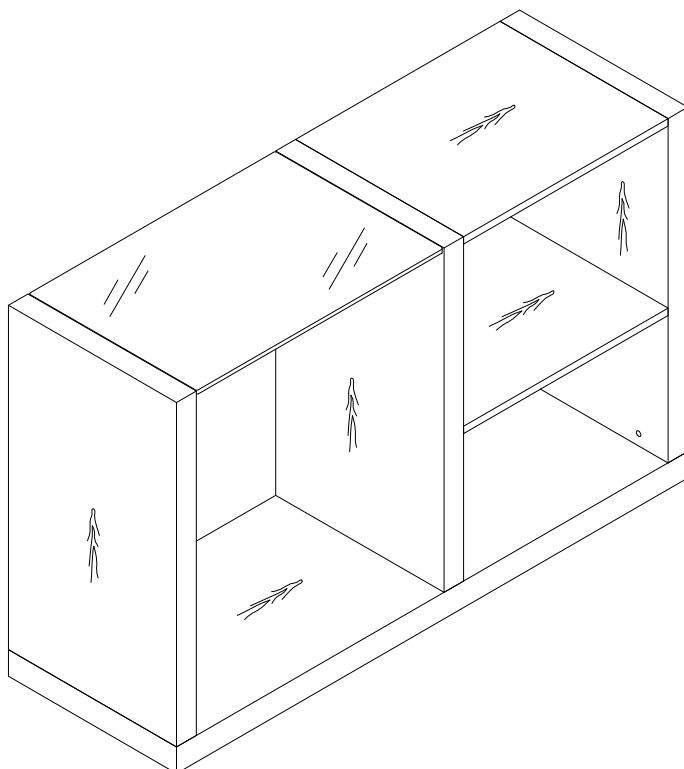

### ASSEMBLY COMPLETED



Please ensure the furniture rests on an even and flat surface. If the product wobbles or feels loose, double-check all bolts and/or screws are properly tightened and secured.



#### Keep this handy!

Please retain this instruction manual and any order-related information for future reference.



#### Lift, don't drag!

To avoid damage to product please always LIFT the product when transporting or adjusting the placement.