

ASSEMBLY INSTRUCTIONS

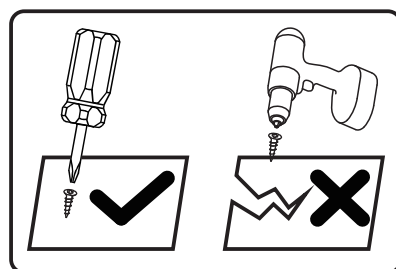
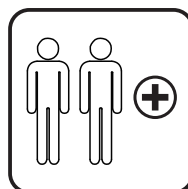
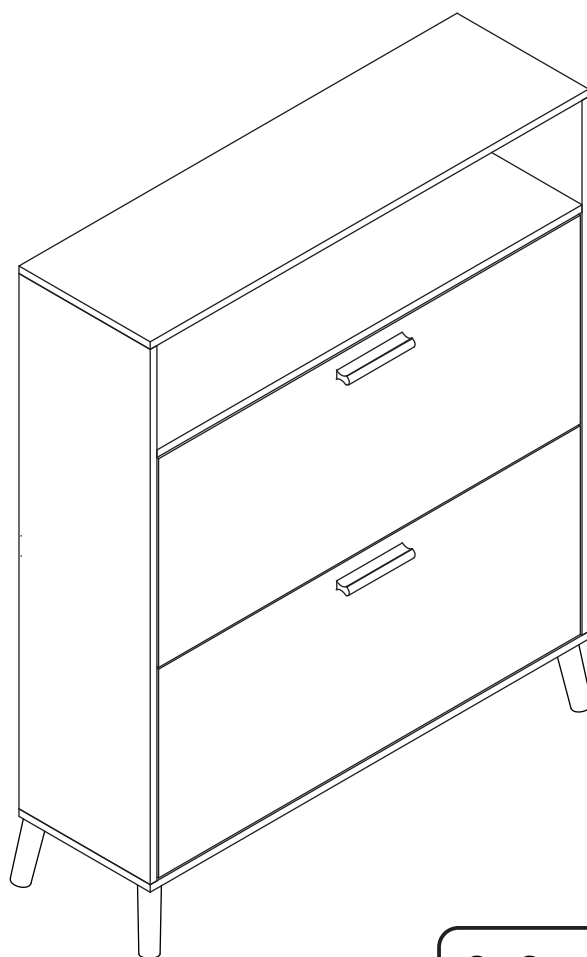

Tools Recommended

THIS INSTRUCTIONS CONTAINS IMPORTANT SAFETY INFORMATION.
PLEASE READ BEFORE ASSEMBLY AND KEEP FOR FUTURE REFERENCE.

IMPORTANT NOTICE

-This product contains small components, please ensure that they are kept away from small children.

-THIS INSTRUCTIONS CONTAINS IMPORTANT SAFETY INFORMATION.
PLEASE READ BEFORE ASSEMBLY AND KEEP FOR FUTURE REFERENCE.

-Read each step carefully. It is very important that each step of instruction is performed in the correct order. If these steps are not followed in sequence, assembly difficulties will occur.

-Make sure all parts are included. Most parts are labelled or stamped on the raw edge.

-Work in spacious area, preferably on a carpet, near the place the unit will be used.

-Do not use power tools to assemble your furniture. Power tools may strip or damage the parts.

-Move your new furniture carefully, with two people lift and carry the unit to it's new location.

-Never push, drag or pull your furniture (especially on carpet)



PLEASE DO NOT RETURN PRODUCT TO US IMMEDIATELY

If a part is missing or damaged, email our customer service.
We will gladly ship your replacement parts FREE of charge.

For Prompt, reliable service, please have your assemble instruction ready

 WARNING	
	Children have died from furniture tipover. To reduce the risk of furniture tipover: <ul style="list-style-type: none">• ALWAYS install anti-tip device provided.• NEVER put a TV on this product.• NEVER allow children to stand, climb or hang on any drawers, doors, or shelves.• NEVER open more than one drawer at a time.• Place heaviest items in the lowest drawers. <p>This is a permanent label. Do not remove!</p>
	

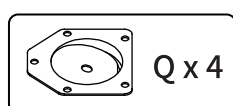
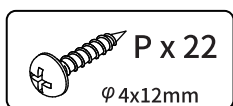
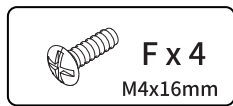
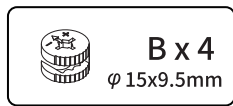
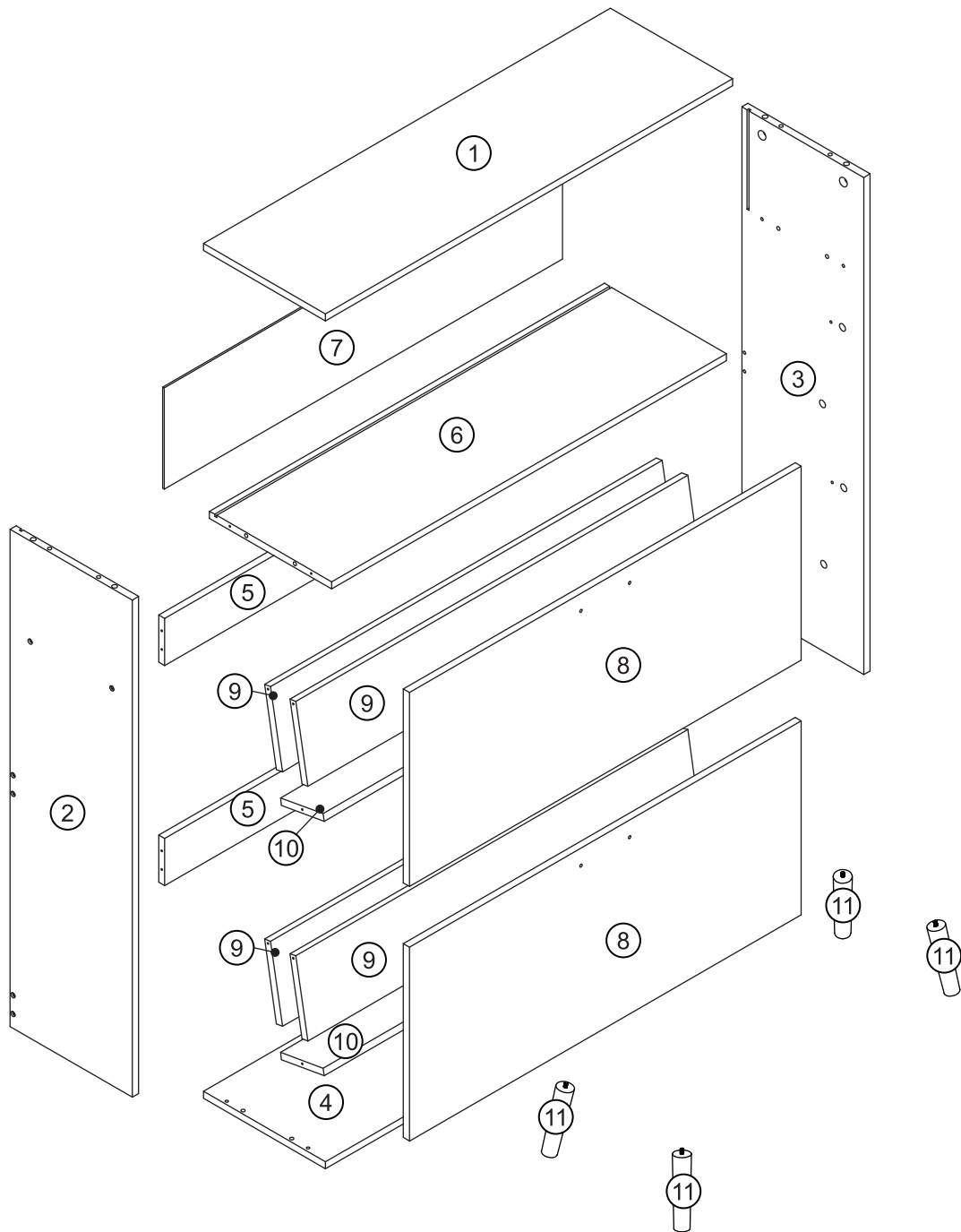

Step 1 Lock screw (A) on the part ①, then use Hardware (T) to install hardware (J) onto parts ② and ③. The installation position is as shown in the figure below.

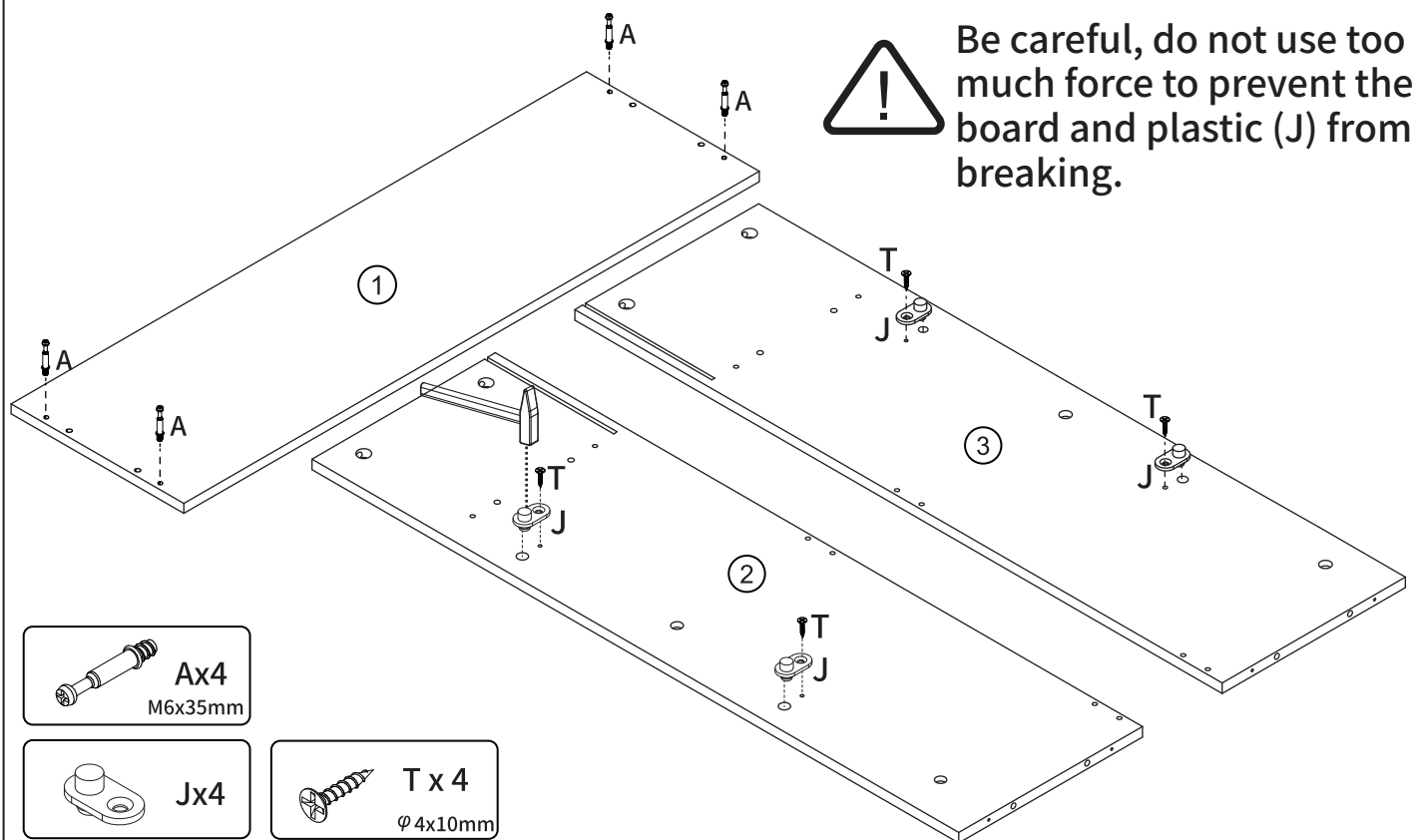

Step 2

Insert the dowel (C) into part ② first, then assemble part ⑤ and part ⑥ to part ② with screw (M).

Part (U) is hole sticker, you can use to cover the hole. The installation position is as shown in the figure below.

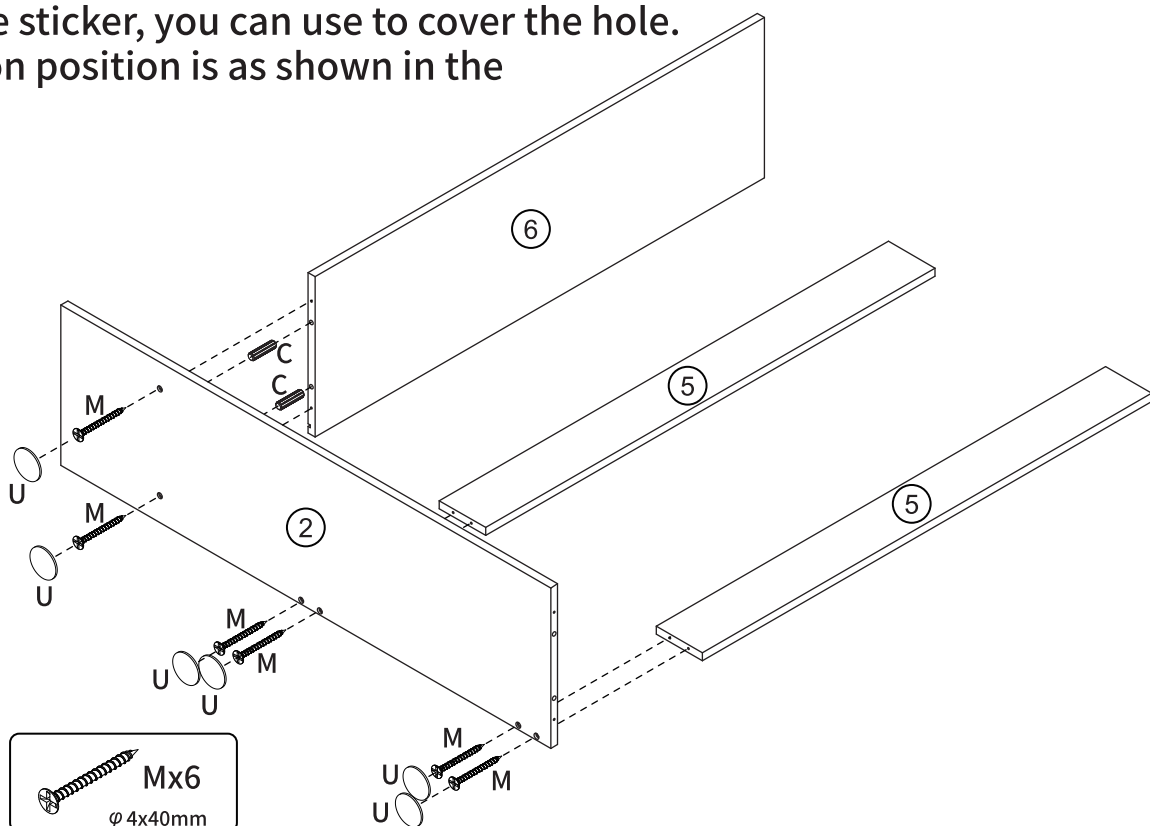

Step 3

Insert the dowel (C) into part ③ first.
Assemble Part ③ with Part ⑤ and ⑥ with screw (M).
Part (U) is hole sticker, you can use to cover the hole.
The installation position is as shown in the figure below.

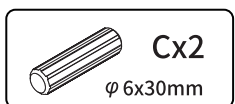
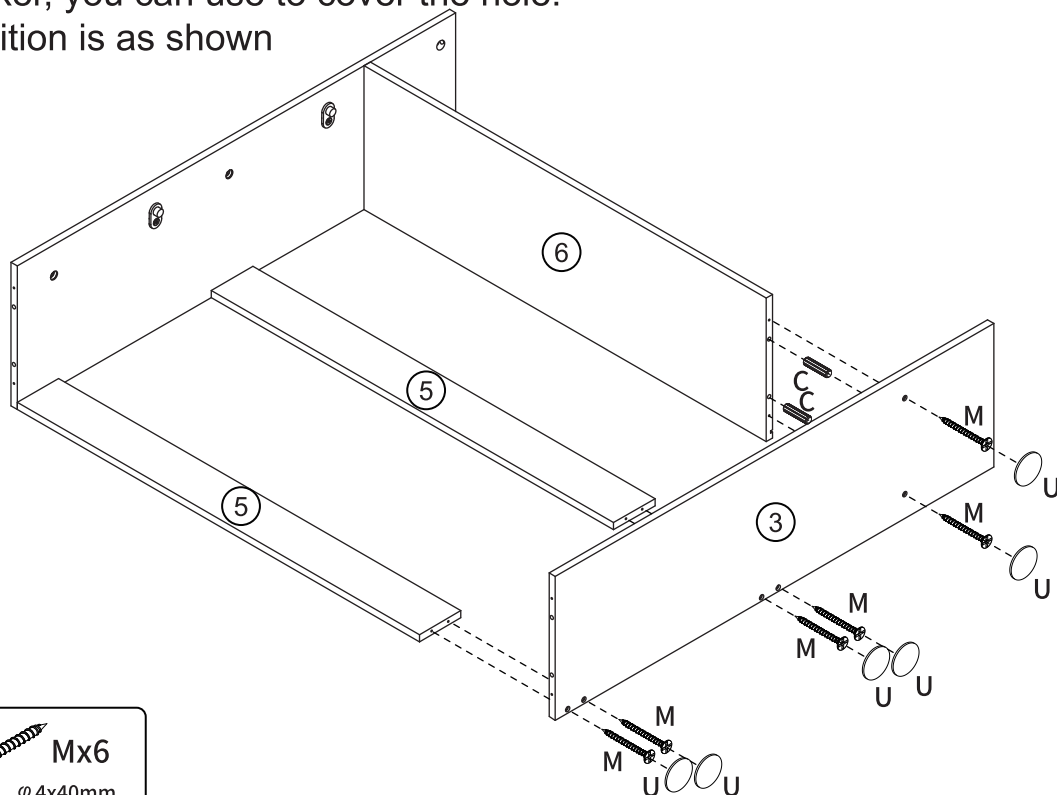

Step 4

Insert dowel (C) into part ② and ③ first, then assemble parts ④ and with screw (M).
The installation position is as shown in the figure below.

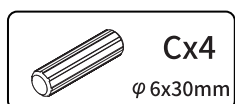
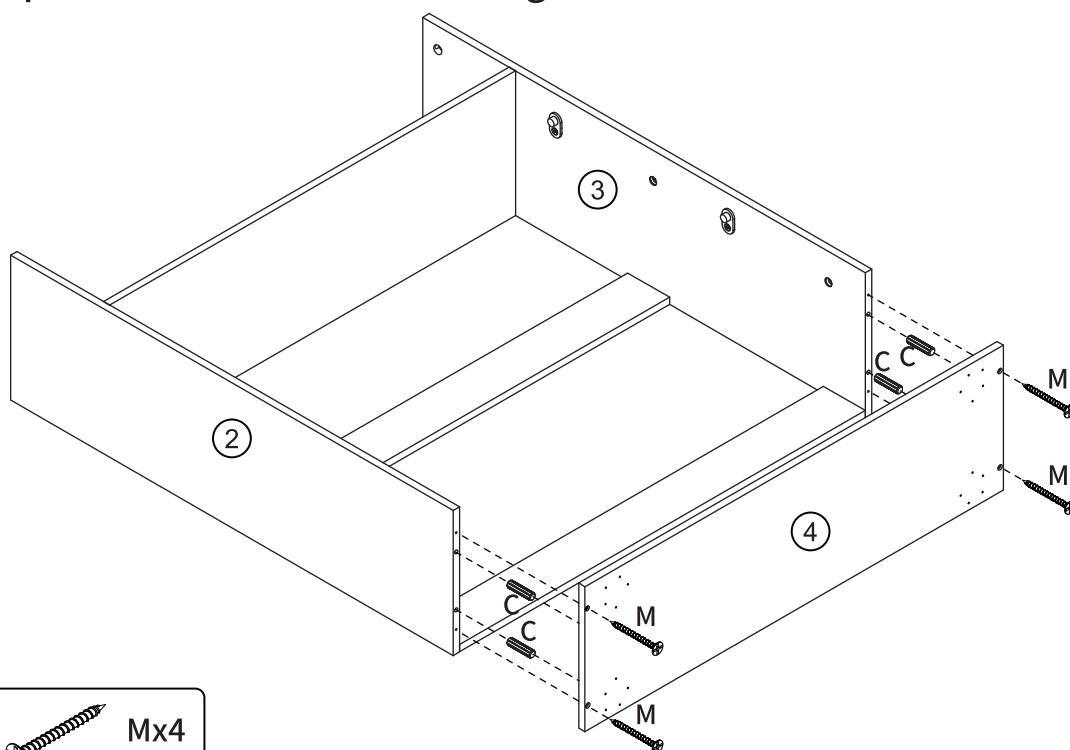

Step 5

Use screw (P) to lock hardware (Q) to part (4).
The installation position is shown in the figure below.

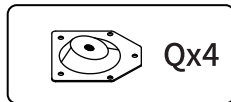
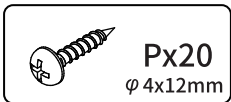
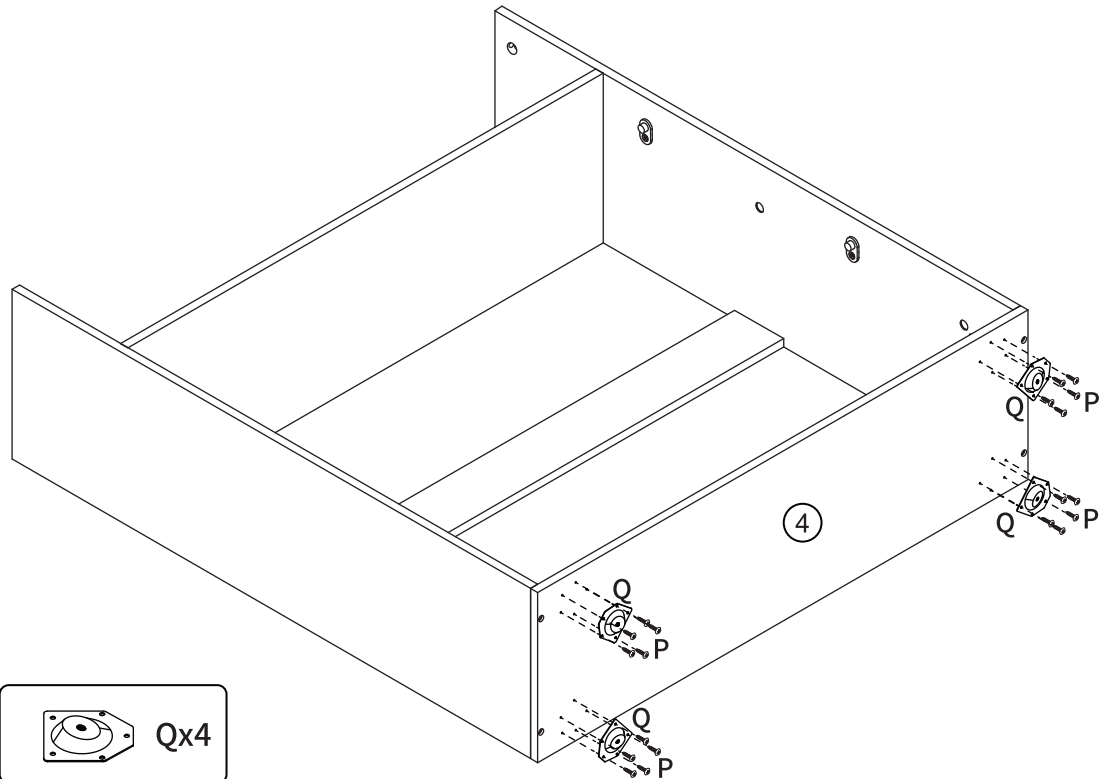

Step 6

Firstly, align the screw ends of the support feet (11) with the hardware (Q) at the four corners and tighten them.
Then tear off the protective film of the foot pad (R) and stick it on the support foot (11).
The installation position is as shown in the figure below.

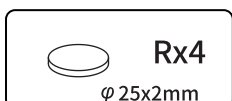
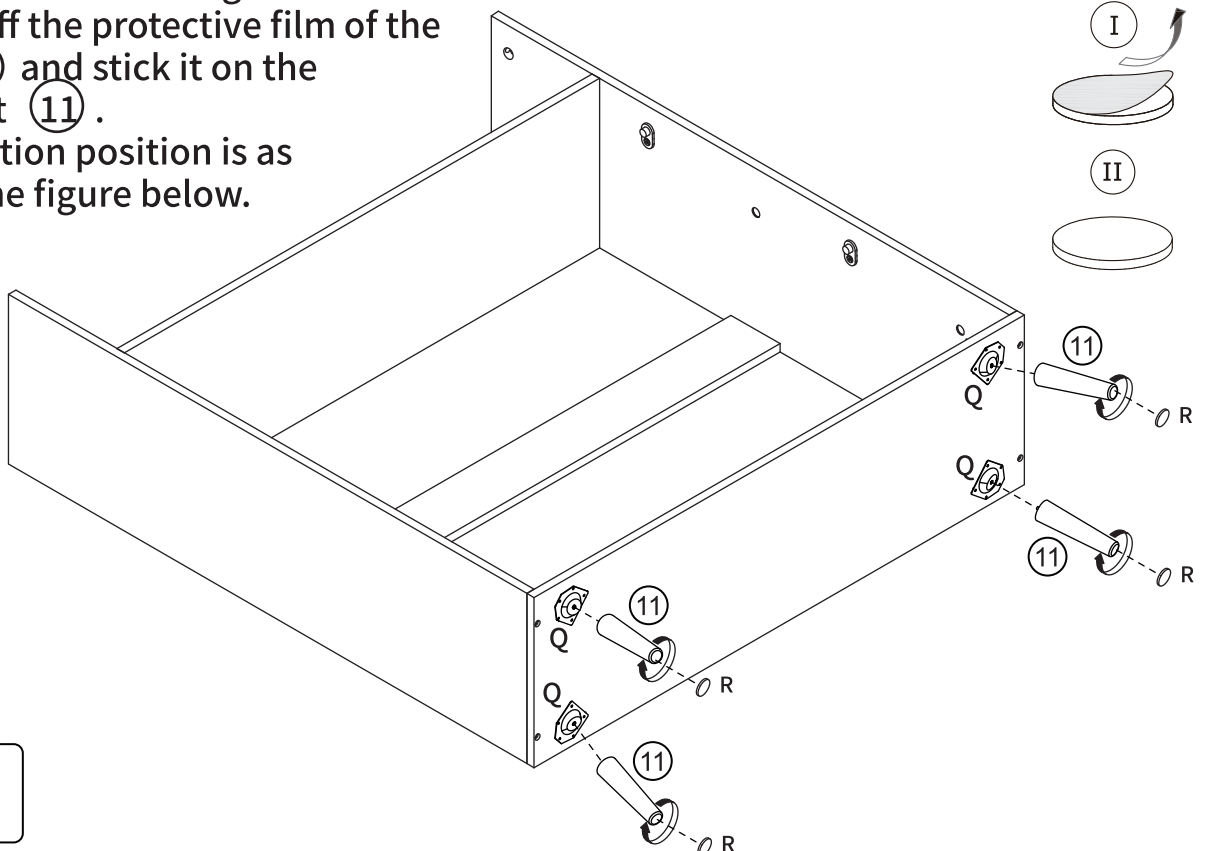

Step 7

Insert part ⑦ along the slot. The position is as shown below.

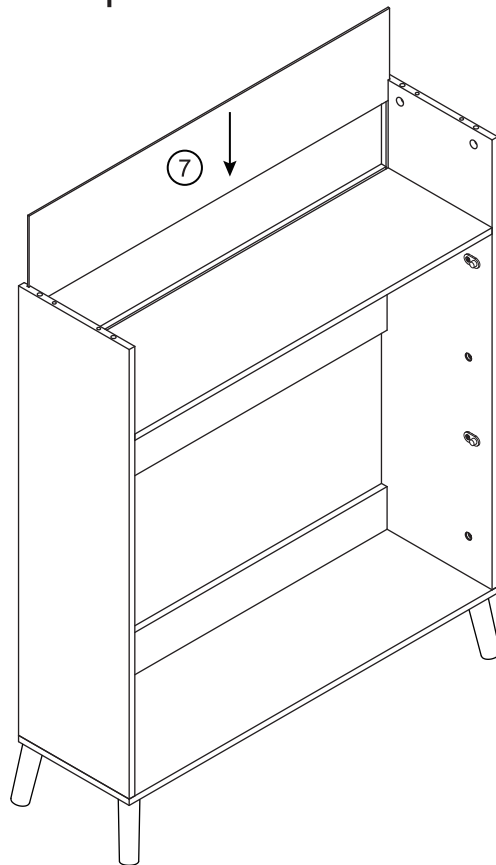

Step 8

Insert dowel (C) into parts ② and ③, then assemble part ① to part ② and ③. Put the eccentric (B) into the corresponding hole and use a flat-blade screw driver to turn it clockwise to tighten. The installation position is as shown below.

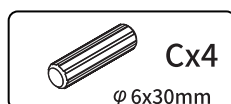
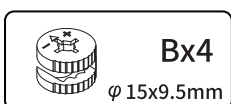
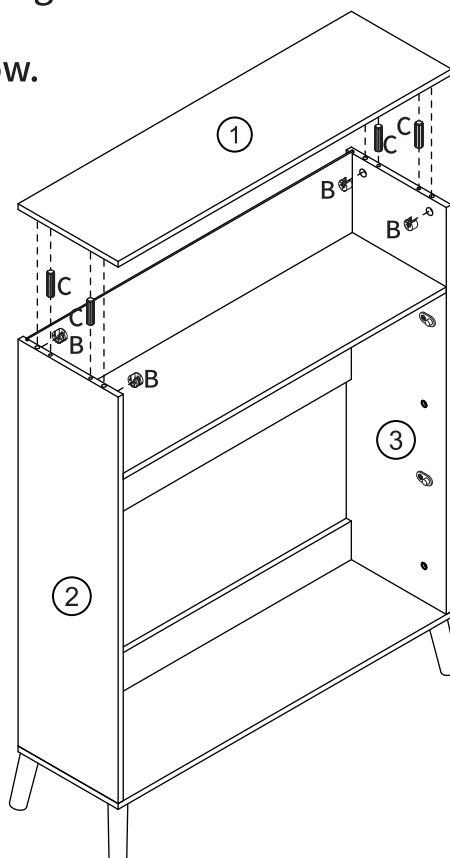
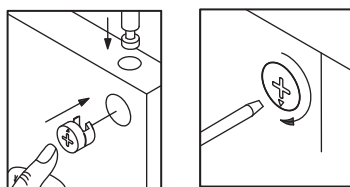

Step 9

Install the anti-rewind assembly (O) on the pilot hole of the part ① using screw (P) first.

Use the screws in component (S) to fasten the back plate buckle.

The installation position is as shown in the figure below.

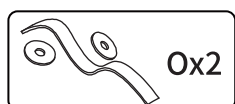
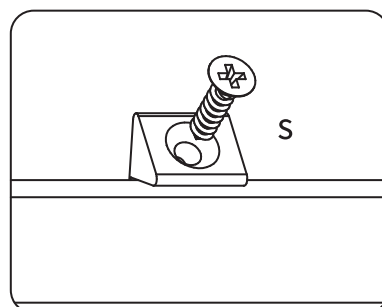
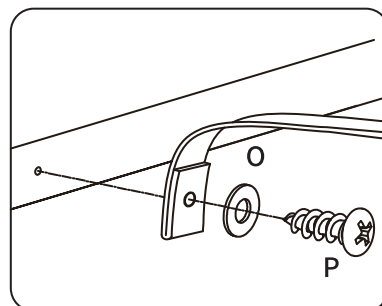
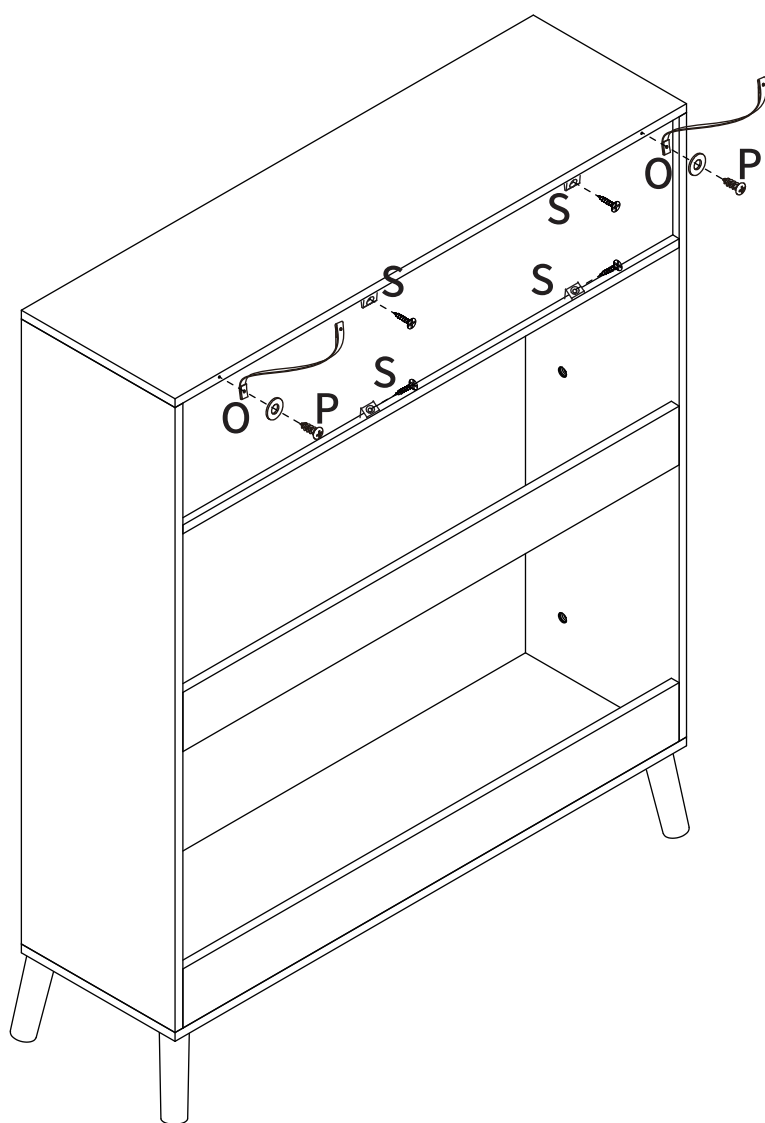

Step 10

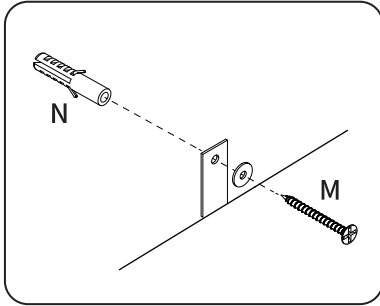

Firstly determine the hole position of the wall, drill holes in the hole position, and insert the expansion screw (N) into the face of the wall. Secondly, place the back of the shoe cabinet against the wall, and install a gasket on the anti-topsoy strip and use screw (M) through the gasket and cloth strip to secure the shoe cabinet to the wall. The installation location is as shown in the figure below.

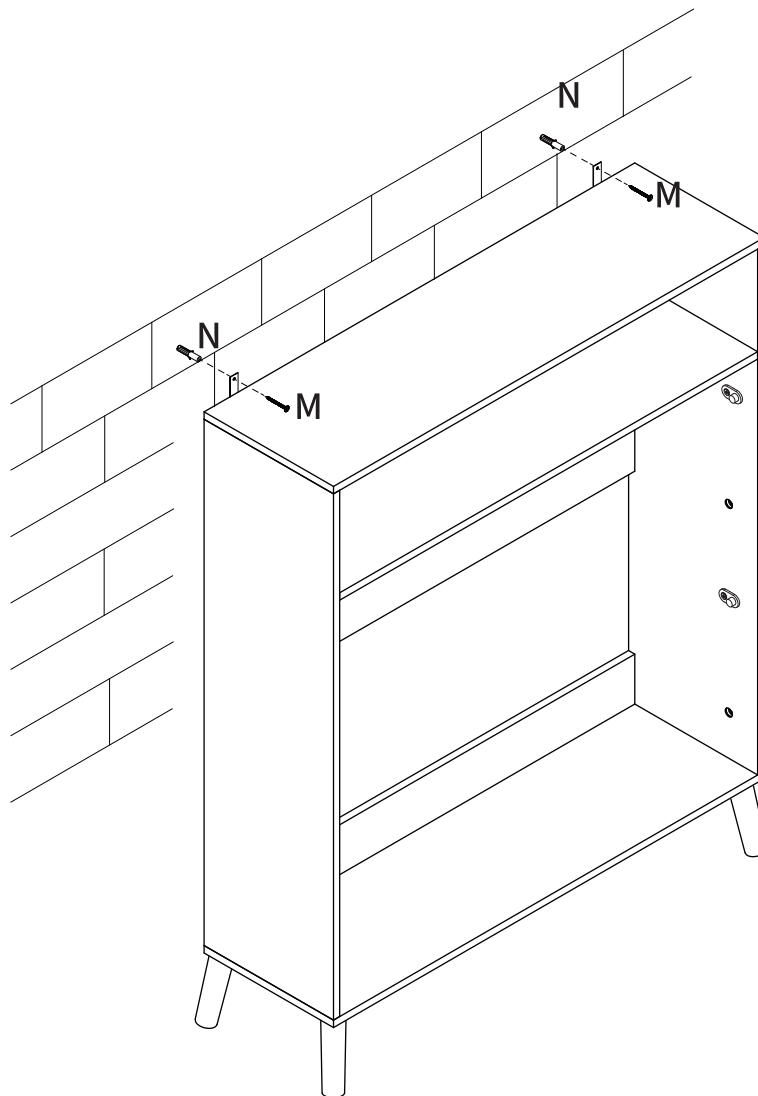

Step 11

Assemble (H) and (G) on the part ⑧ with screw (D), and then install handle (E) on the part ⑧ with screw (F). The installation position is as shown in the figure below.

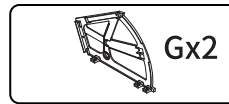
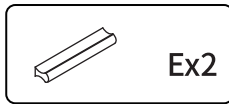
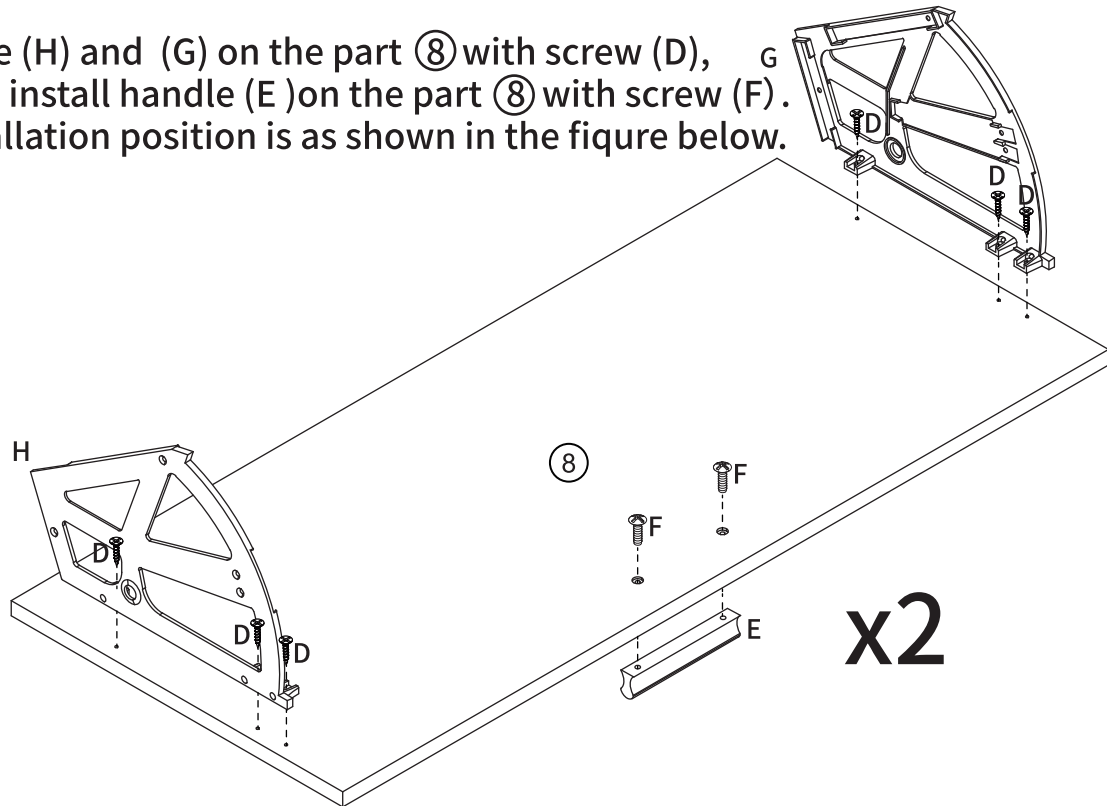

Step 12

Install the part ⑨ and ⑩ on (H) and (G) using screw (D). The installation position is as shown in the figure below.

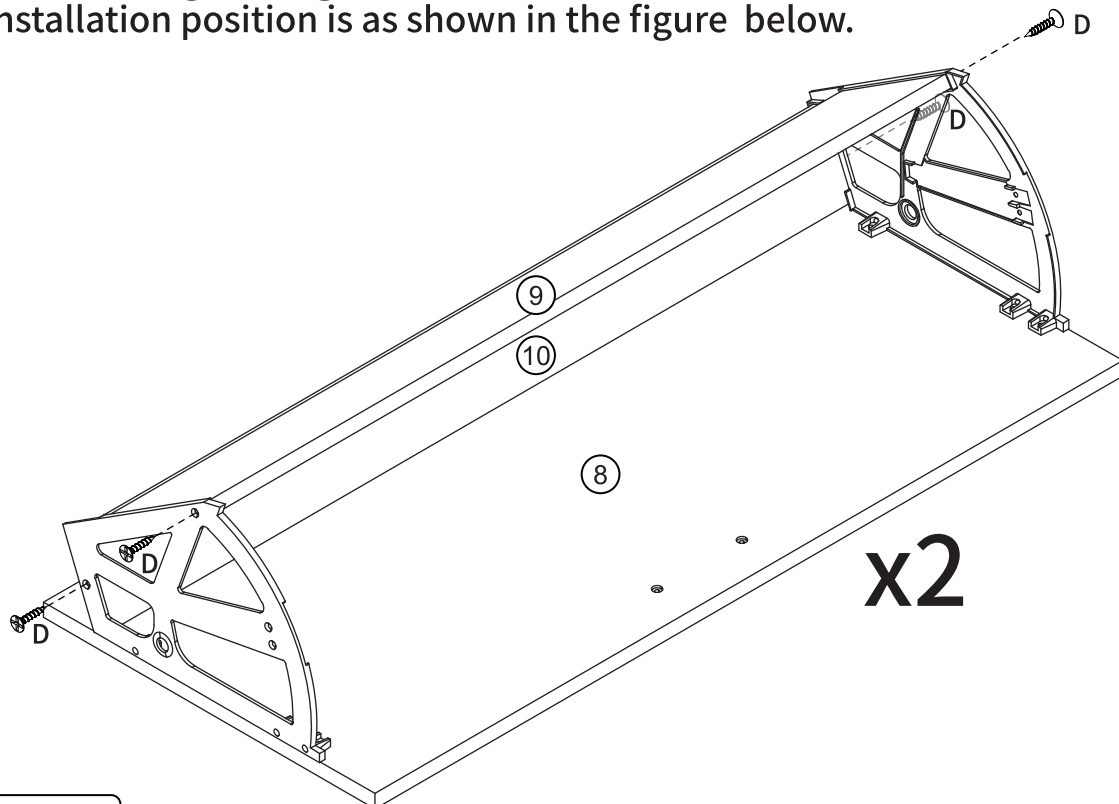

Step 13 Install hardware (K) as shown, then lock it on parts ② and ③ using screw (L) and wrench (I).
The installation position is as shown in the figure below.

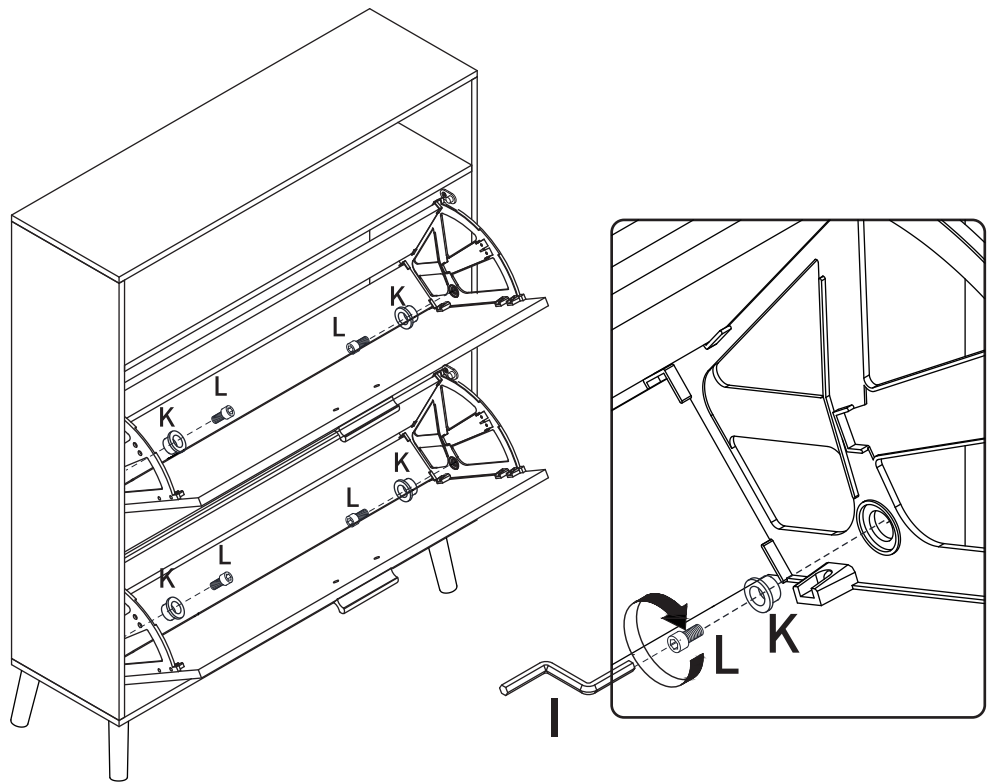
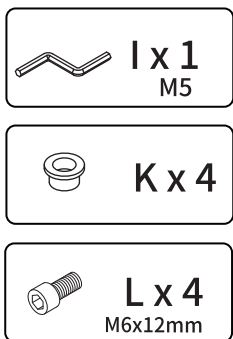

Step 14

Fasten the part ⑨ to (H) and (G) with screw (D).
The installation position is as shown below.

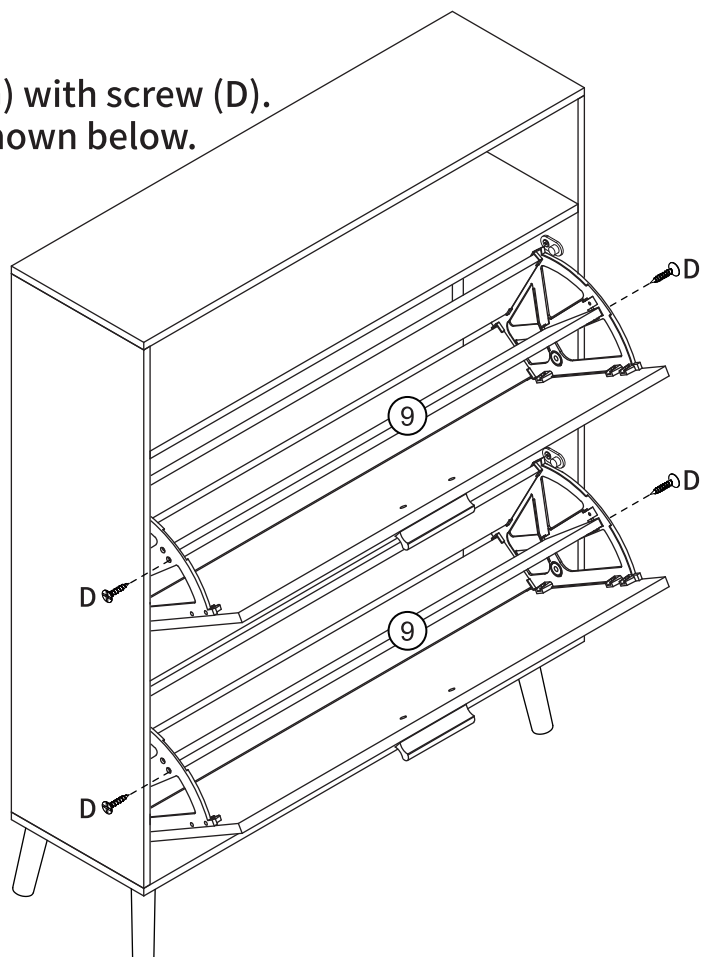

Step 15

