

# ASSEMBLY INSTRUCTIONS

Read this instruction carefully. See hardware and Furniture part list for guidance.  
 Be sure all parts are complete, before you assemble. Pace all wooden prevent from being scratched.  
 Follow the figure to start assembling.

**CAUTIONS:** 1. Do not FULLY- TIGHTEN the nut or bolt until all nut and bolt is ready assembled.  
 2. Do not OVER - TIGHTEN the nut or bolt avoid causing damages to the thread.  
 3. Keep all hardware parts out of reach of children.

NOTE: THE LIST AND QUANTITY SHOWN ARE FOR 1 UNIT ASSEMBLY.

PART LIST		
ITEM	DESCRIPTION	QTY
A	LEG (1)	1 PC
B	LEG (2)	1 PC
C	BACK TOP	1 PC
D	CUSHION SEAT	1 PC
E	CORNER BLOCK	1 PC

HARDWARE LIST		
ITEM	DESCRIPTION	QTY
1	WOOD DOWEL M8 x 30mm	4 PCS
2	JCBC SCREW M6 x 30mm	4 PCS
3	JCBC SCREW M6 x 70mm	4 PCS
4	SPRING WASHER M6	8 PCS
5	FLAT WASHER M6 x 13mm	8 PCS
6	I0543 L BRACKET	4 PCS
7	PEN HEAD SCREW M4 x 12mm	8 PCS
8	CSK SCREW M4 x 25mm	4 PCS
9	ALLEN KEY M4	1 PC

## STEP 01

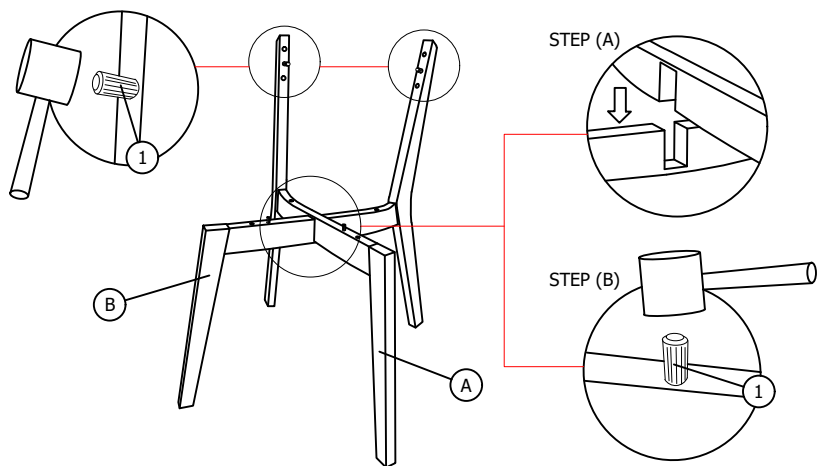

## STEP 02

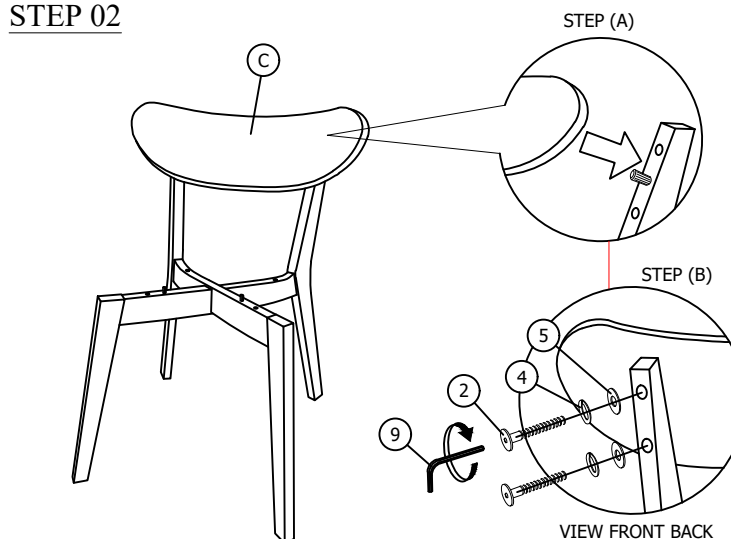

## STEP 05

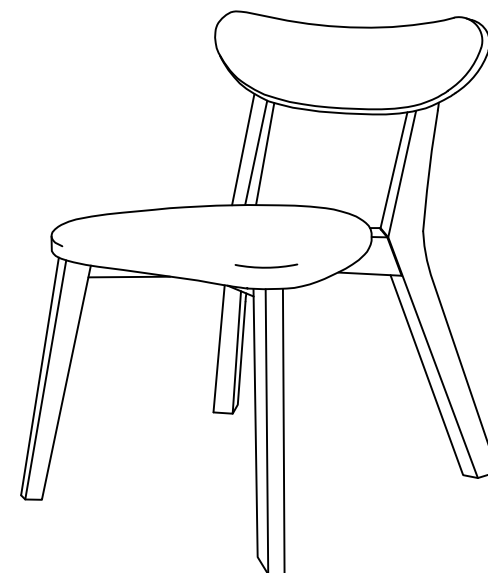

## STEP 03

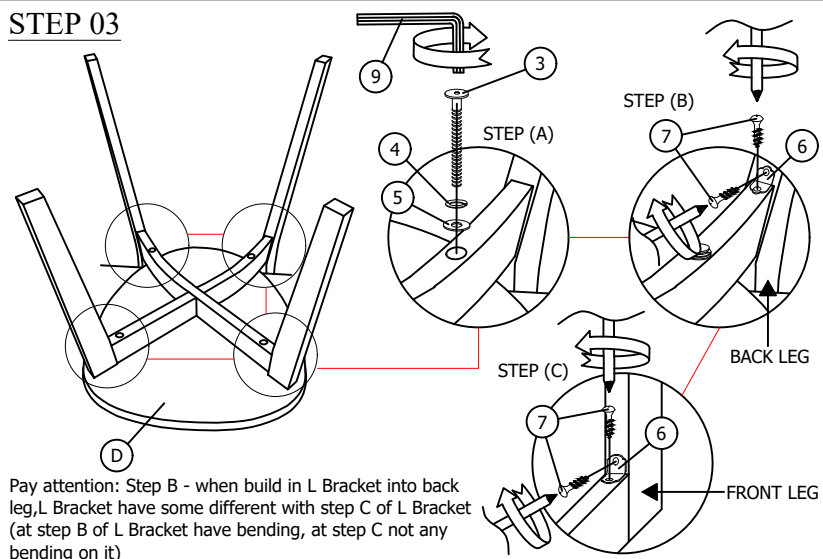

## STEP 04

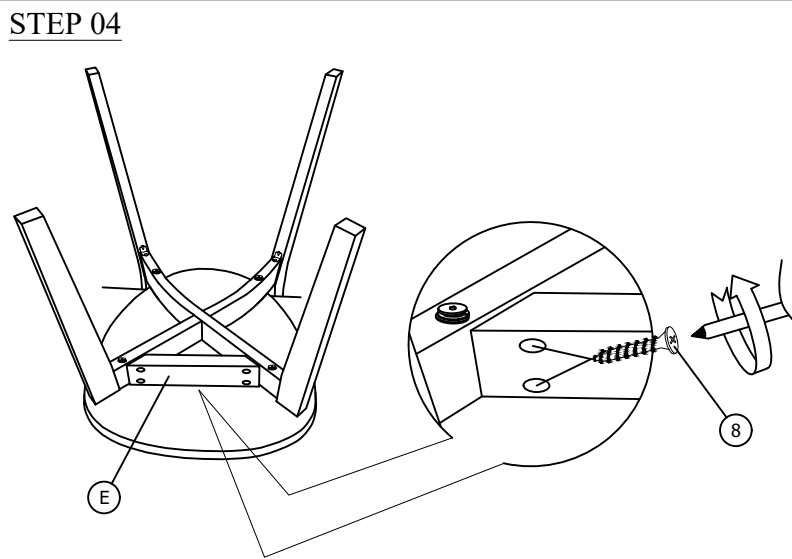

FULLY SET-UP (CHAIR)