

ASSEMBLY INSTRUCTIONS

QUEEN BED

is packed in 3 cartons









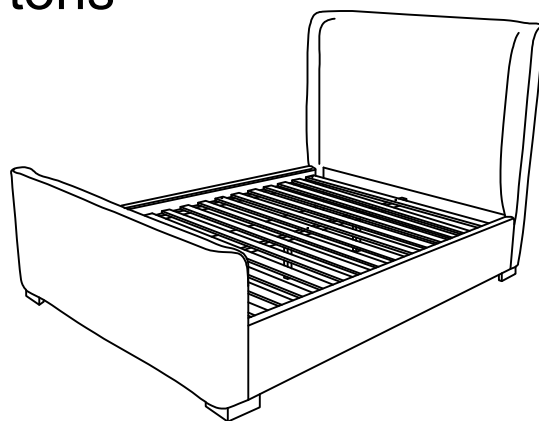

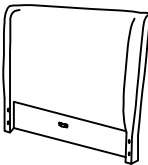
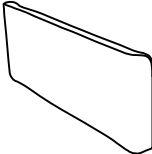
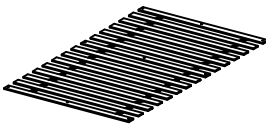
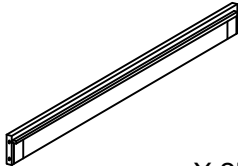

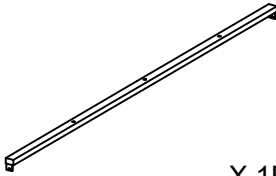
THANK YOU FOR PURCHASING THIS QUALITY PRODUCT.
 READ THESE INSTRUCTIONS CAREFULLY.
 SEE PARTS LIST AND HARDWARE LIST FOR GUIDANCE,
 BE SURE ALL PARTS ARE PRESENT PRIOR TO ASSEMBLY.

CAUTIONS:

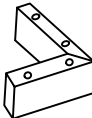
1. DO NOT FULLY TIGHTEN BOLTS UNTIL ALL BOLTS ARE IN PLACE AND READY FOR ASSEMBLY.
2. DO NOT OVER TIGHTEN BOLTS TO AVOID CAUSING DAMAGE TO THE THREADS.
3. KEEP ALL PARTS AND HARDWARE OUT TO REACH OF CHILDREN.
4. REQUIRE 2 PEOPLE TO ASSEMBLY.

TOOLS NEEDED : SCREWDRIVER (NOT PROVIDED)



Carton	Item	Designation	Part	Hardware
1	8322 Q - HB	Headboard	A  X 1PC	
2	8322 Q - FB	Footboard	B  X 1PC	
		Slats	C  X 1SET	
3	8322 Q - SR	Side Rail	D  X 2PCS	1.JCBC BOLT M6 x 60mm  x 11pcs
		Center Support	E  X 1PC	2.JCBB BOLT M8 x 35mm  x 8pcs
		Center Support Leg	F  X 3PCS	3.FLAT WASHER M8 x 18mm  x 8pcs
		Bed Leg	G  X 4PCS	4.SPRING WASHER M8 x 13mm  x 8pcs
				5.CSK SCREW M4 x 20mm  x 2pcs
				6.CSK SCREW M4 x 38mm  x 9pcs
				7.ALLEN KEY M4  x 1pc
				8.ALLEN KEY M5  x 1pc

STEP 1

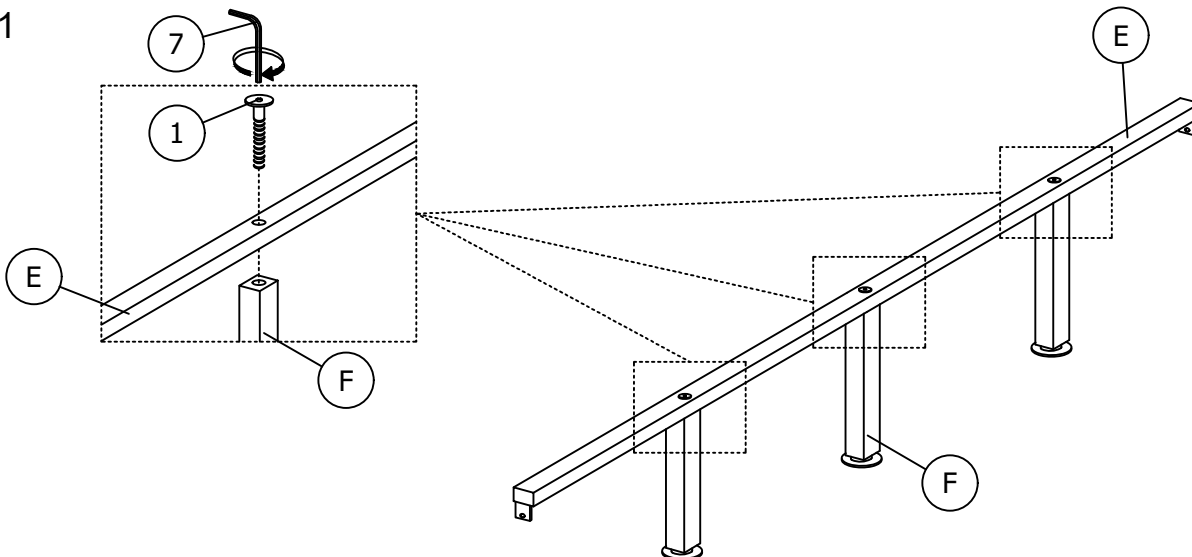

STEP 2

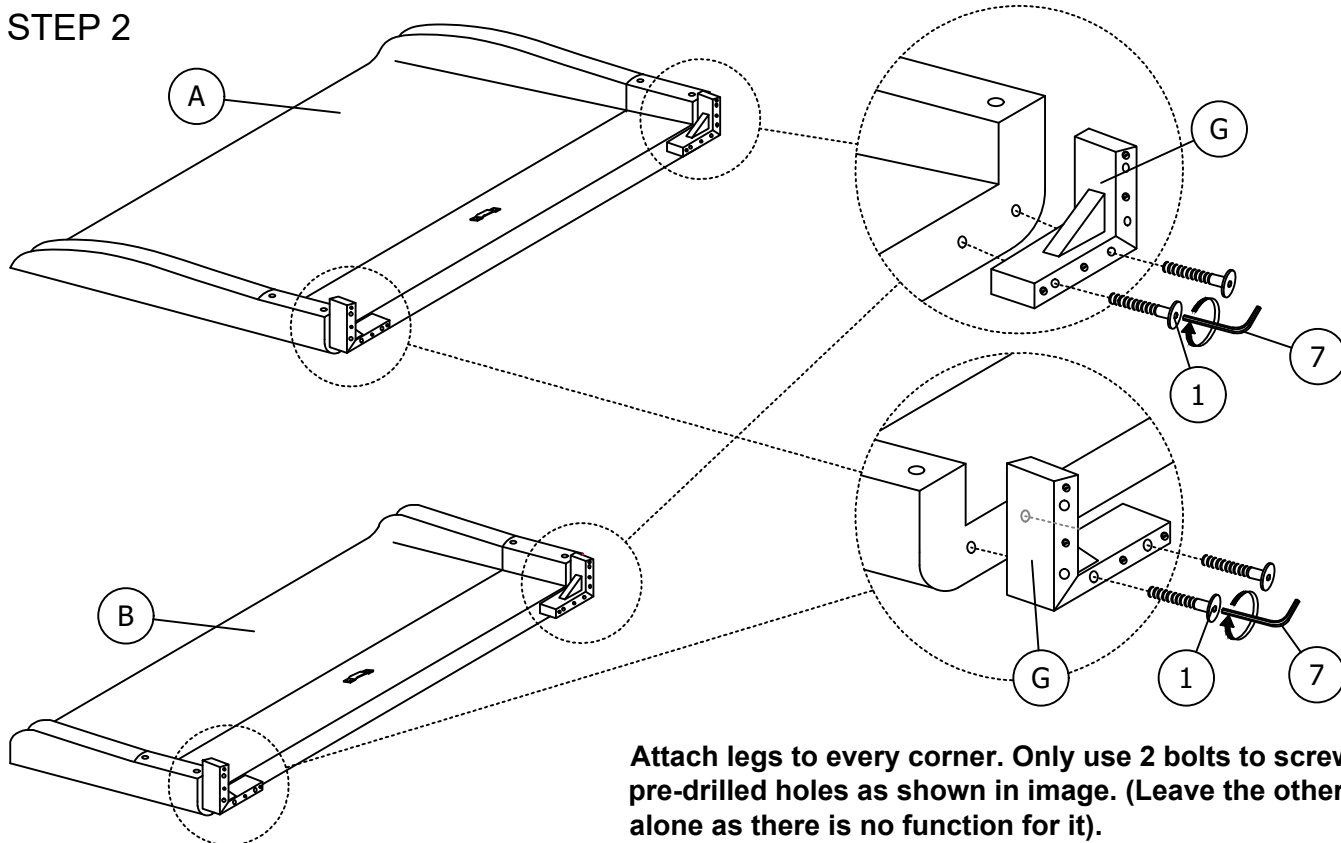

STEP 3

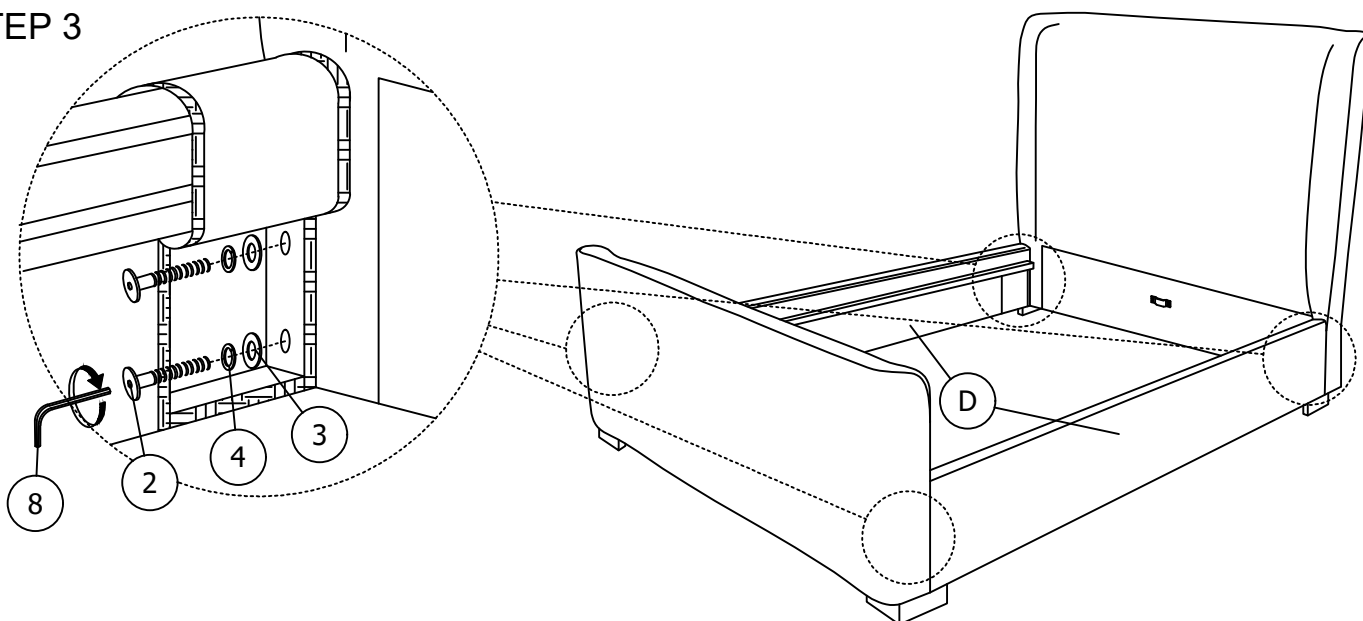

Repeat this step in all 4 corners to connect Side Rails to Headboard and Footboard.

STEP 4

Secure and tighten screws to attach Center Support to Headboard and Footboard. Make sure Center Support is leveled correctly.

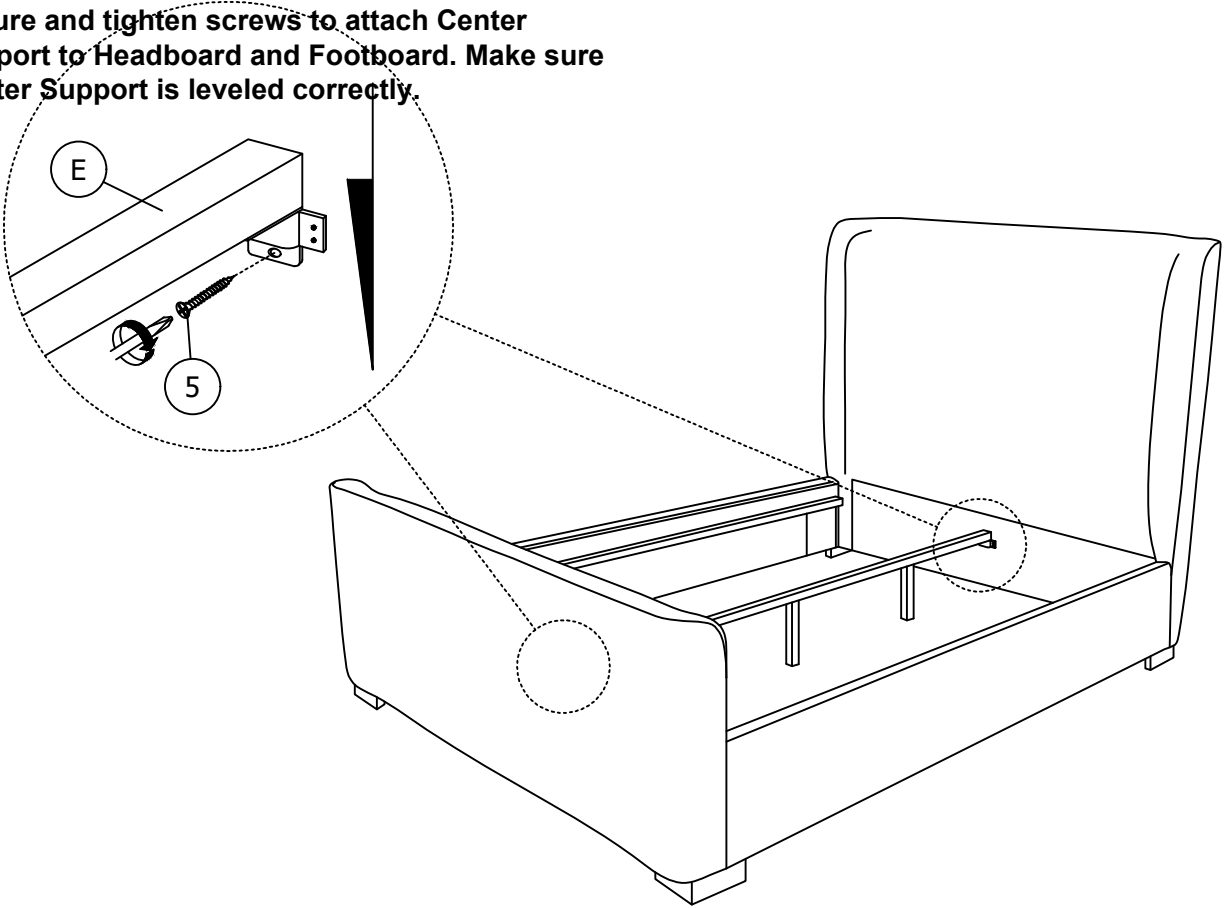

STEP 5

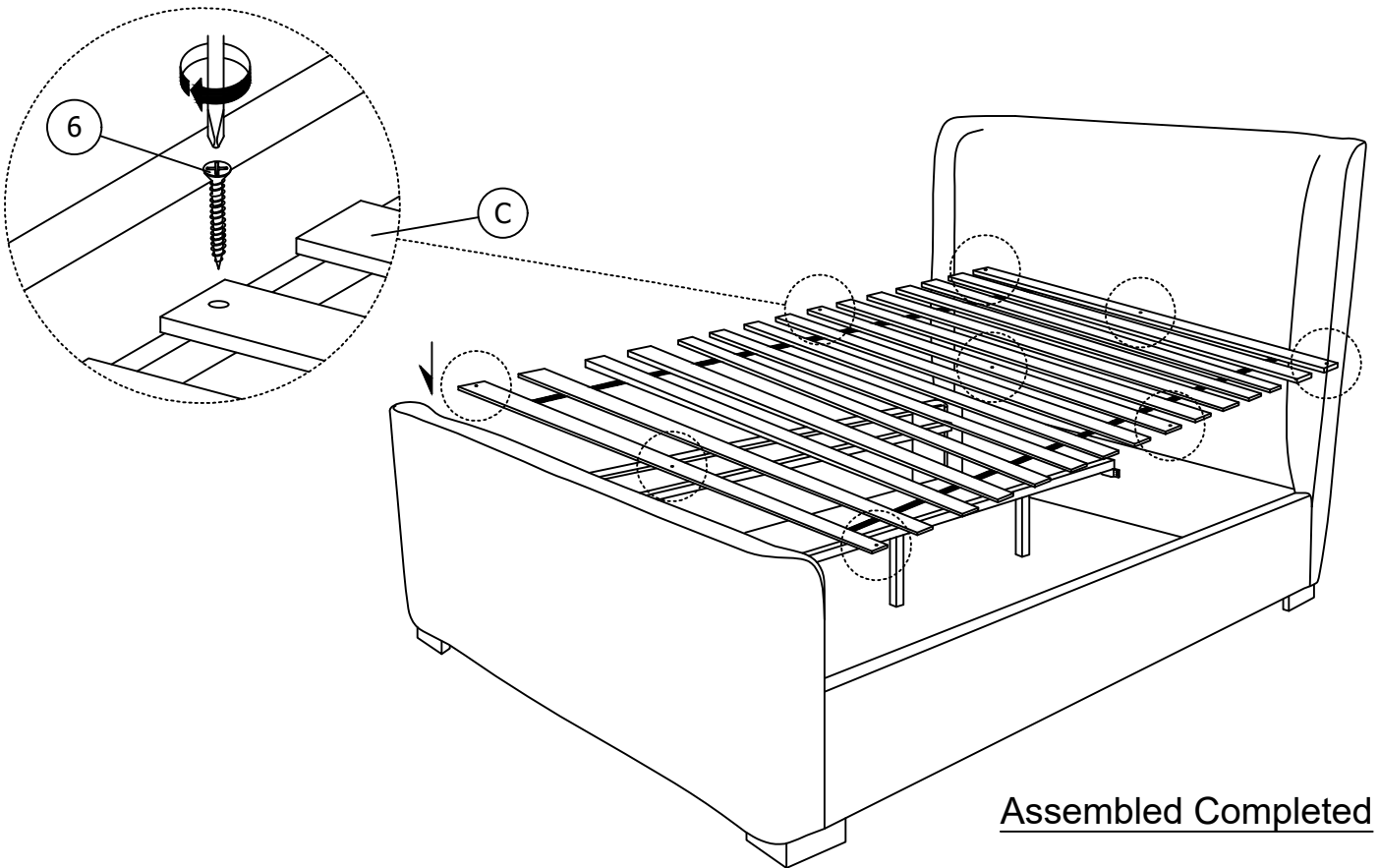

Reminder: Please ensure all bolts and screws are tightened and secure before you use it.

*** When moving bed position, the center support leg levelers must be adjust up right to avoid breakage of the leg and center support.**