







# WINSTON®

Assembly instructions for M69084-ST

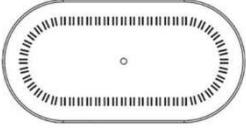
KD Table Parts		
Image	Description	Qty
	Table Leg	4
	Table Short Leg	2
	Center Ring	1
	Table Top	1

Hardware		
Image	Description	Qty
	1/4-20 X 1 1/2" Hex Bolt	8
	5/16 X 1 3/4 Ss Wshr Hh Bolt	6
	Lock washer 5/16"	6

## General Instructions

1. Separate and identify all parts, ensuring that all listed components are present.
2. To avoid scratches during assembly, use a soft surface or a cardboard box as a work area.
3. Follow the step-by-step instructions carefully.
4. Do not tighten bolts until all bolts and washers are properly installed.
5. Tighten bolts securely, but do not overtighten.

## Step 1

- Attach legs to the center ring using 5/16" x 1 3/4" bolts and 5/16" lock washers. **Do not tighten yet.**

## Step 2

- Place the tabletop on a flat/soft surface. Position the pre-assembled base legs over the tabletop, aligning the leg holes to the holes in the tabletop.

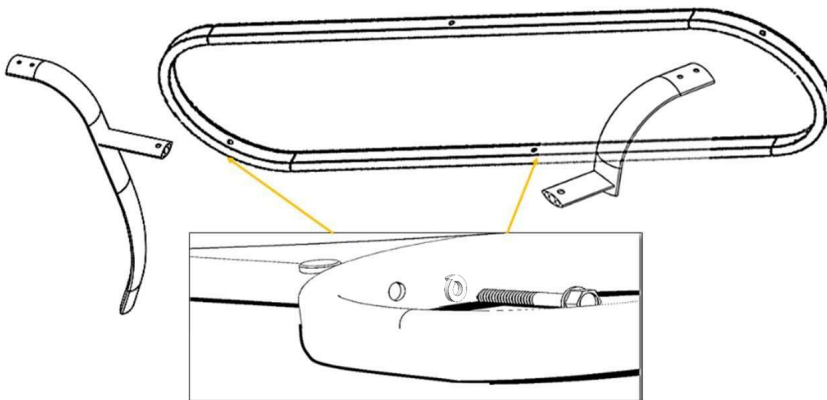

**Step 1**

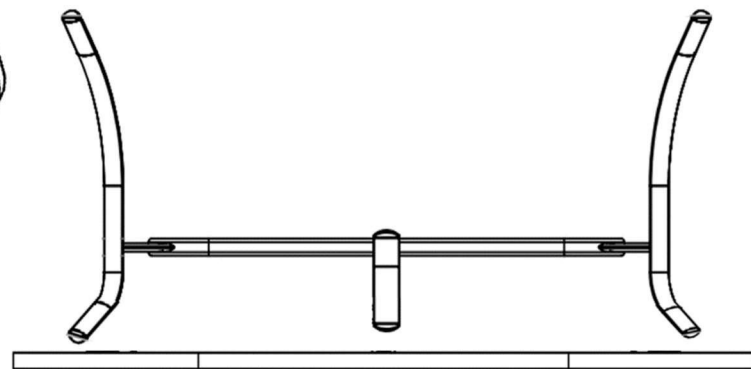

**Step 2**

# WINSTON®

Assembly instructions for M69084-ST

## Step 3

- Attach and secure pre-assembled base legs to the tabletop using 1/4" X 1 1/2 " Hex bolts, tighten these bolts before next step.

## Step 4

- Flip the table into an upright position on a flat surface, adjust or align the legs if needed to level, and then tighten the center ring bolts and lock washers to complete the assembly.

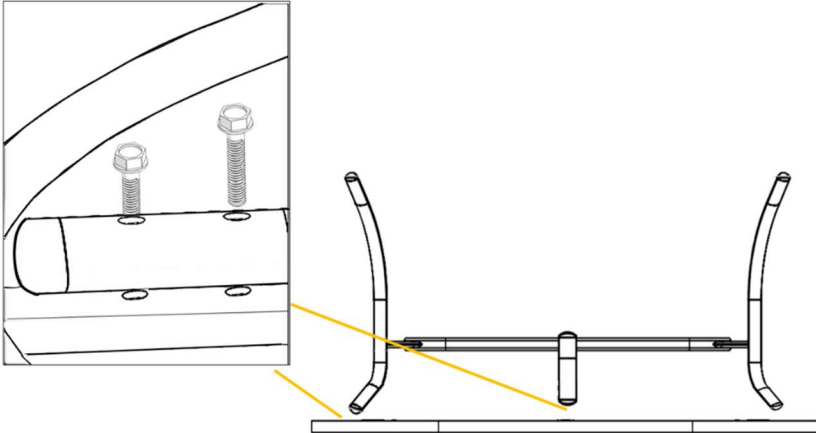

## Step 3

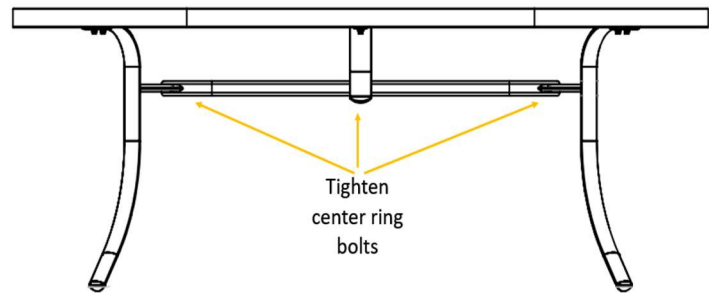

## Step 4

### Notes:

- Do not allow children to play with plastic wrapping or small parts, as these could be potential choking hazards. Discard immediately.
- Do not stand or climb on this KD Table
- Periodically check and ensure that all the bolts are completely tightened