

QUEEN/E.KING/CAL.KING STORAGE BED ASSEMBLY INSTRUCTIONS

BOX #1

(A) HEADBOARD: 1PC

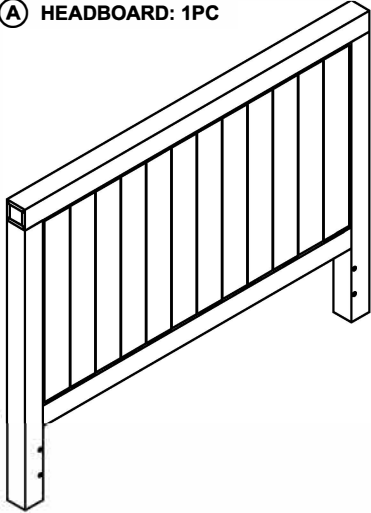

BOX #2

B1. FOOTBOARD
C. SLAT ROL

1 PC
1PC(13 SLATS)

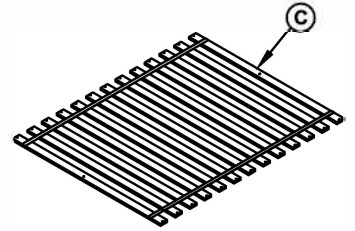
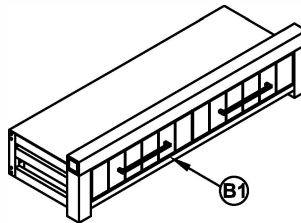

BOX #3

(D) SIDE RAIL: 2PCS

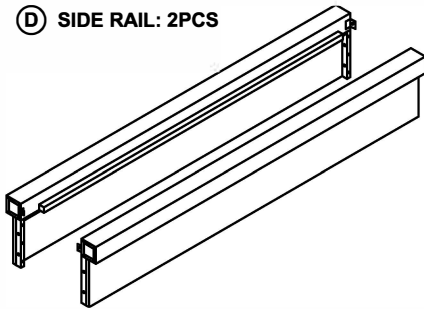

(E) CENTER RAIL: 1PC

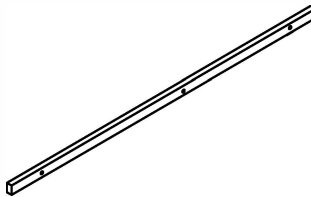

(F) CENTER LEGS: 2PCS

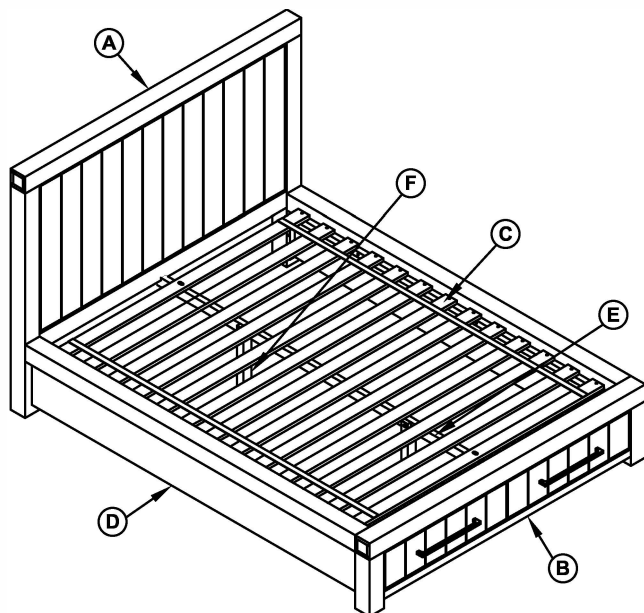

HARDWARE PACKED IN BOX #3

(1) ALLEN BOLT (M8x60): 8PCS



(2) ALLEN BOLT (M6x30): 4PCS



(3) FLAT WASHER (M8): 12PCS



(4) LOCK WASHER (M8): 12PCS



(5) ALLEN KEY: 1PC

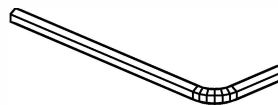

(6) WOOD SCREW (M4x30): 28PCS



(7) ALLEN BOLT (M8x25): 4PCS



QUEEN/E.KING/CAL.KING STORAGE BED ASSEMBLY INSTRUCTIONS



STEP 1

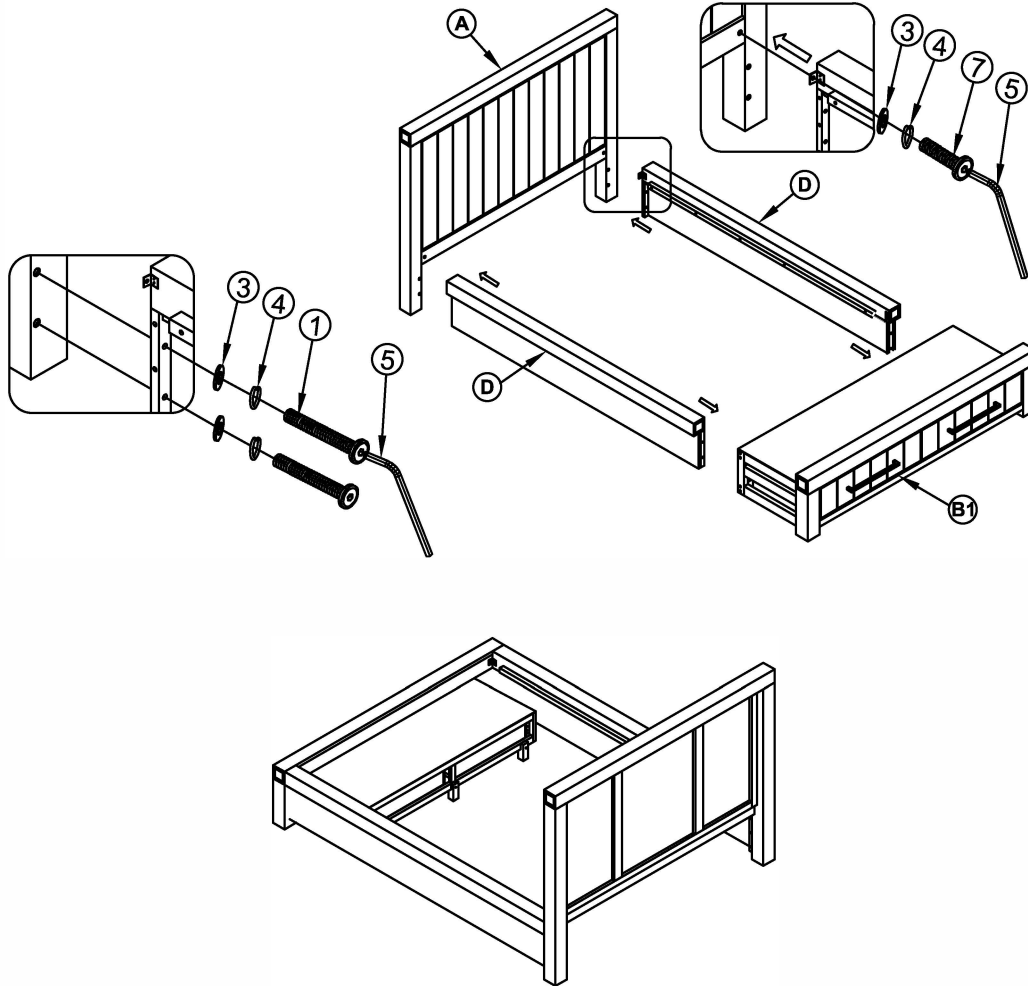

STEP 2

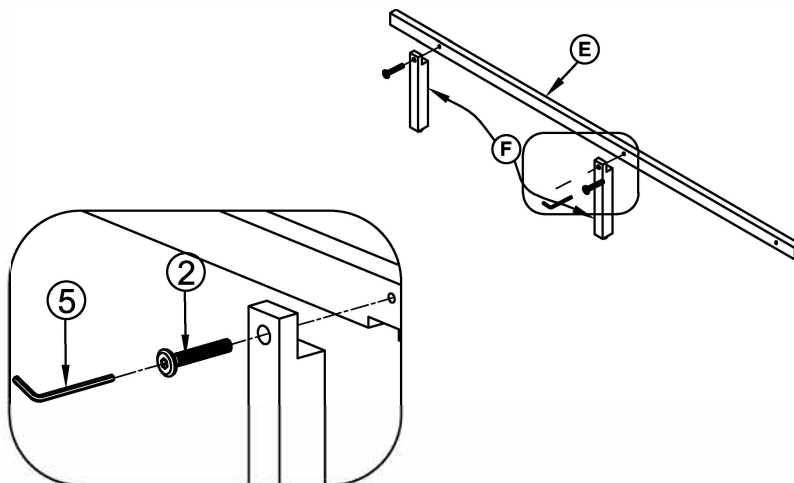

QUEEN/E.KING/CAL.KING STORAGE BED ASSEMBLY INSTRUCTIONS

STEP 3

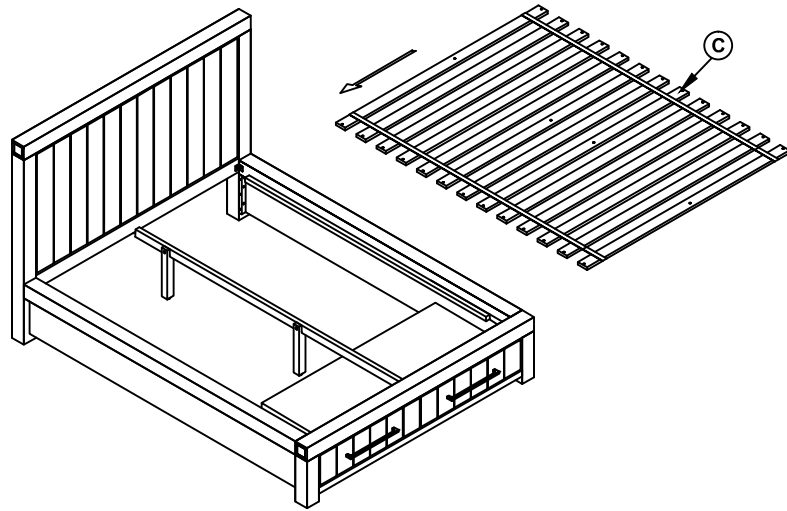

STEP 4

NOTE!: Phillips head screw driver for wood screws is not included in hardware.

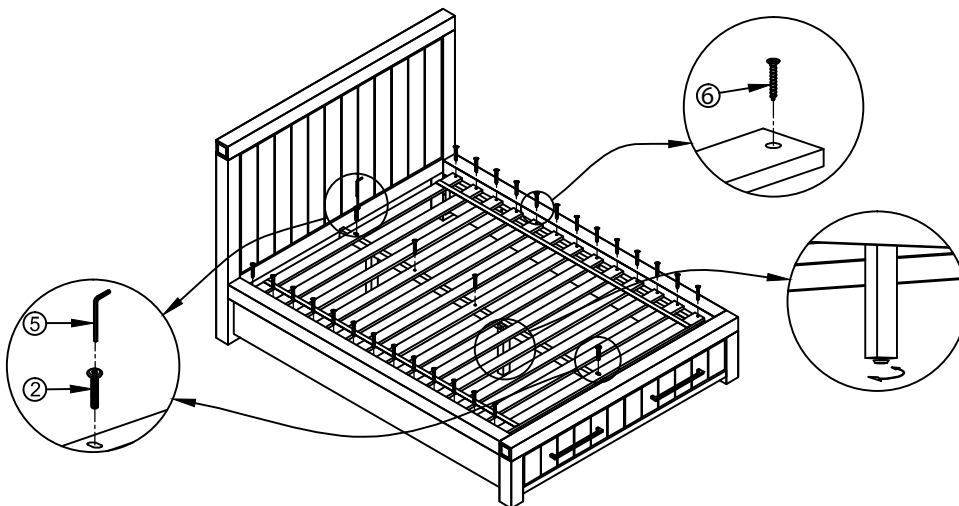

INSTRUCTIONS FOR ADJUSTING LEVELER :

Position the bed in your room
locate levelers under each leg
support.

Turn counter-clock wise to
extend clockwise to contract.

Adiust levelers until each leg
support is applying equal
upward pressure on the bed
slat.

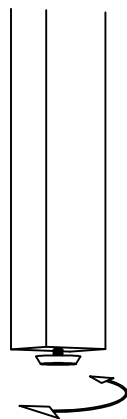

MAINTENANCE INTRUCTIONS :

- Remove box spring and mattress before moving your bed.
- Lift your bed when moving it. Dragging can damage leg support.
- Readjust levelers after moving your bed