

Assembly Instructions

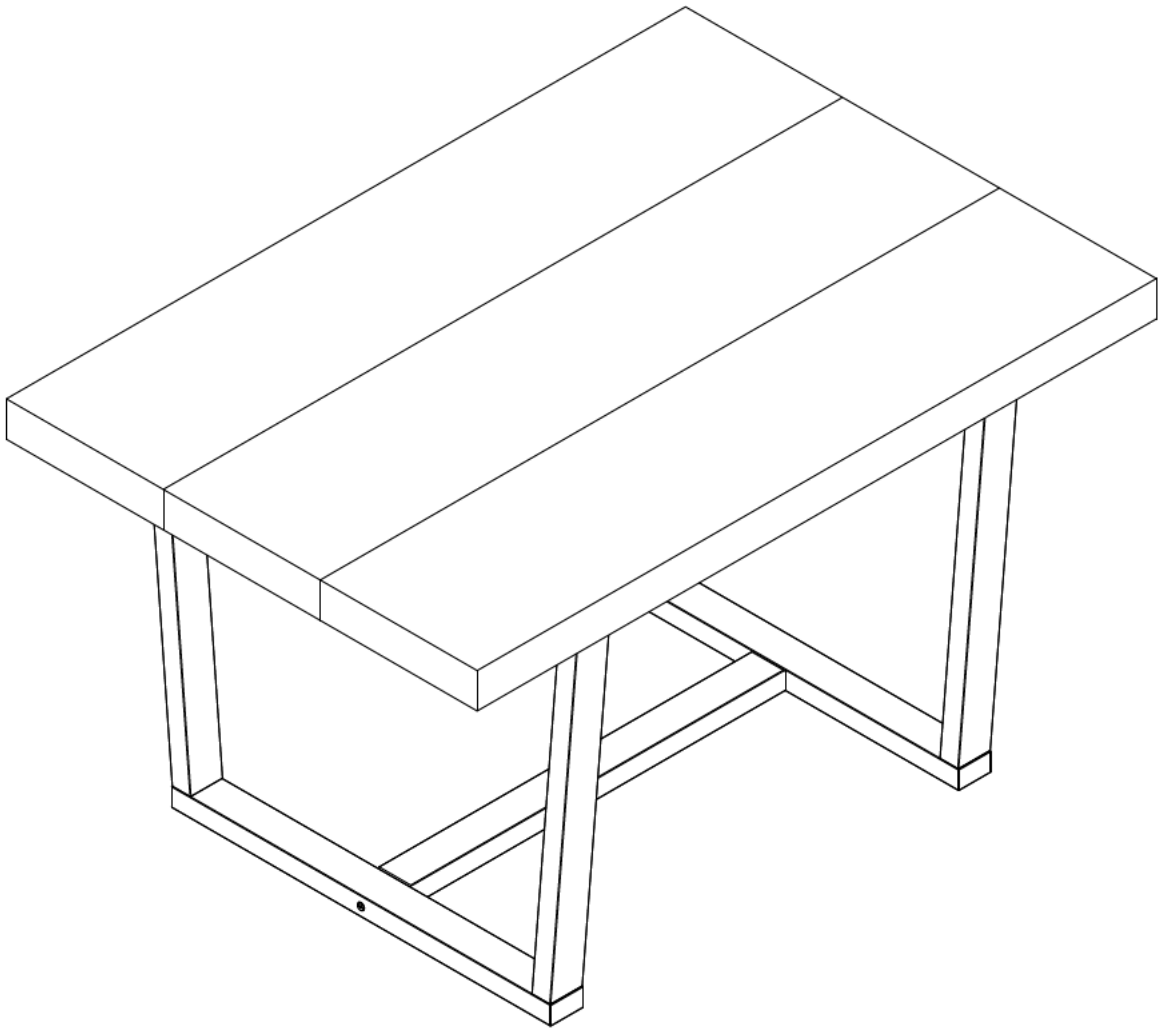

General Assembly Guidelines

- I. Ensure that all parts and hardware are available before beginning assembly.
- II. Follow each step carefully to ensure the proper assembly of this product.
- III. Two people are recommended for ease in the assembly of this product.
- IV. The three main types of hardware used to assemble this product are : wood dowels , screws and bolts.
- V. A Phillips head screwdriver is required for the assembly of this product .

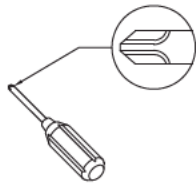



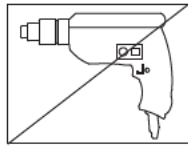

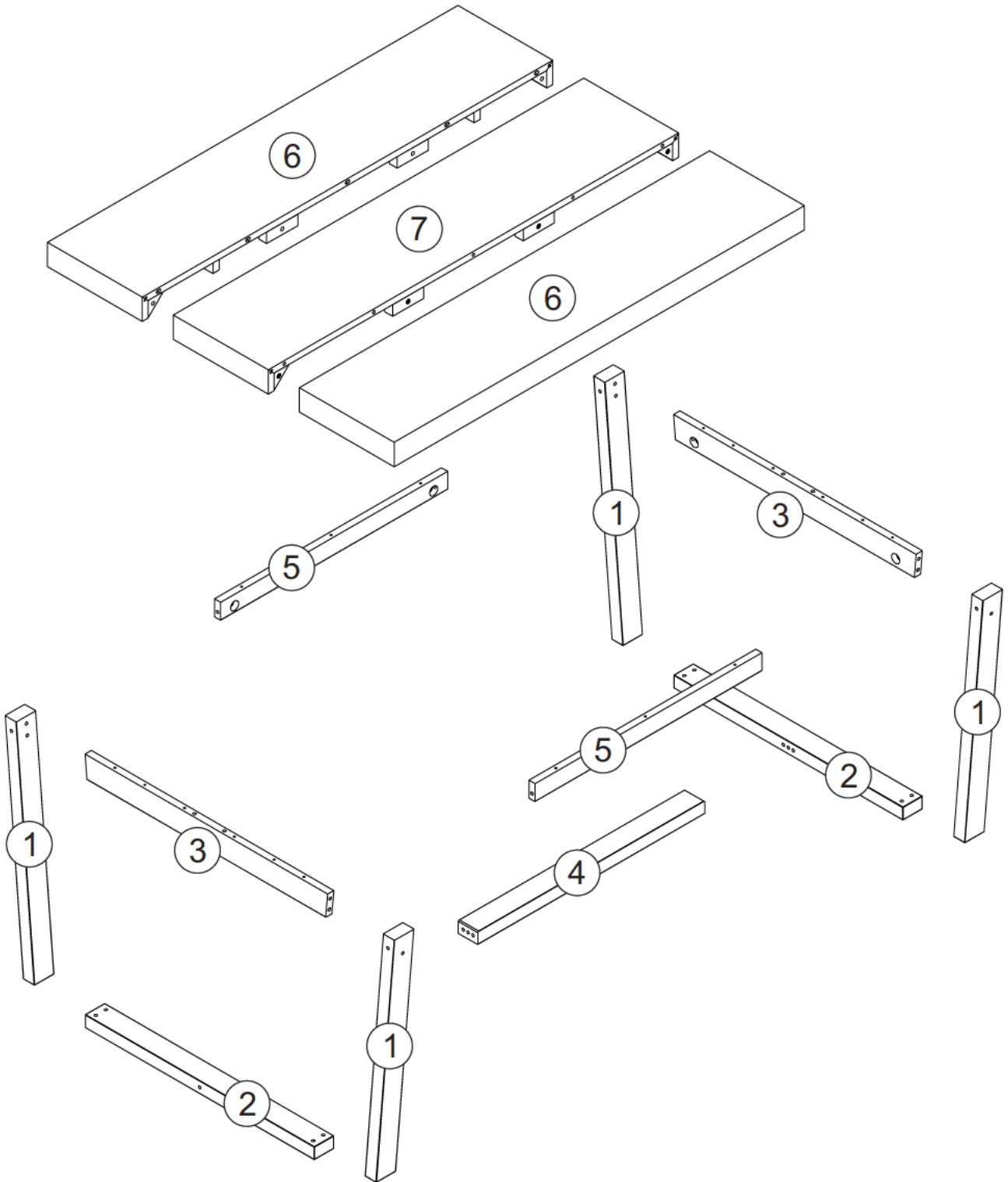

- VI. Power tools should not be used to assemble this product .



Parts List

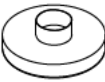
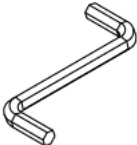

Hardware List

A		Ø 1/4" x 110 mm	Bolt	10 pcs
B		Ø 7.0 x 70 mm	Bolt	08 pcs
C		Ø 1/4" x 50 mm	Bolt	08 pcs
D		Ø 4.0 x 50 mm	Screw	18 pcs
E		Ø 8.0 x 30 mm	Wood dowel	22 pcs
F		Ø 1/4"	Barrel nut	10 pcs
G			Plastic foot	04 pcs
H		M4	Hex key	01 pcs

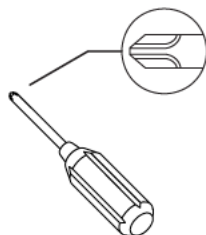
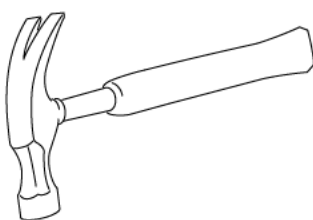

Phillips head screwdriver required for assembly
(not included)

Mallet or hammer recommended for assembly
(not included)

***The hardware quantities listed above are required for proper assembly.
Some extra hardware may also have been included.***

Step 1

Insert wood dowel (E) into parts (3), (4) and (7).

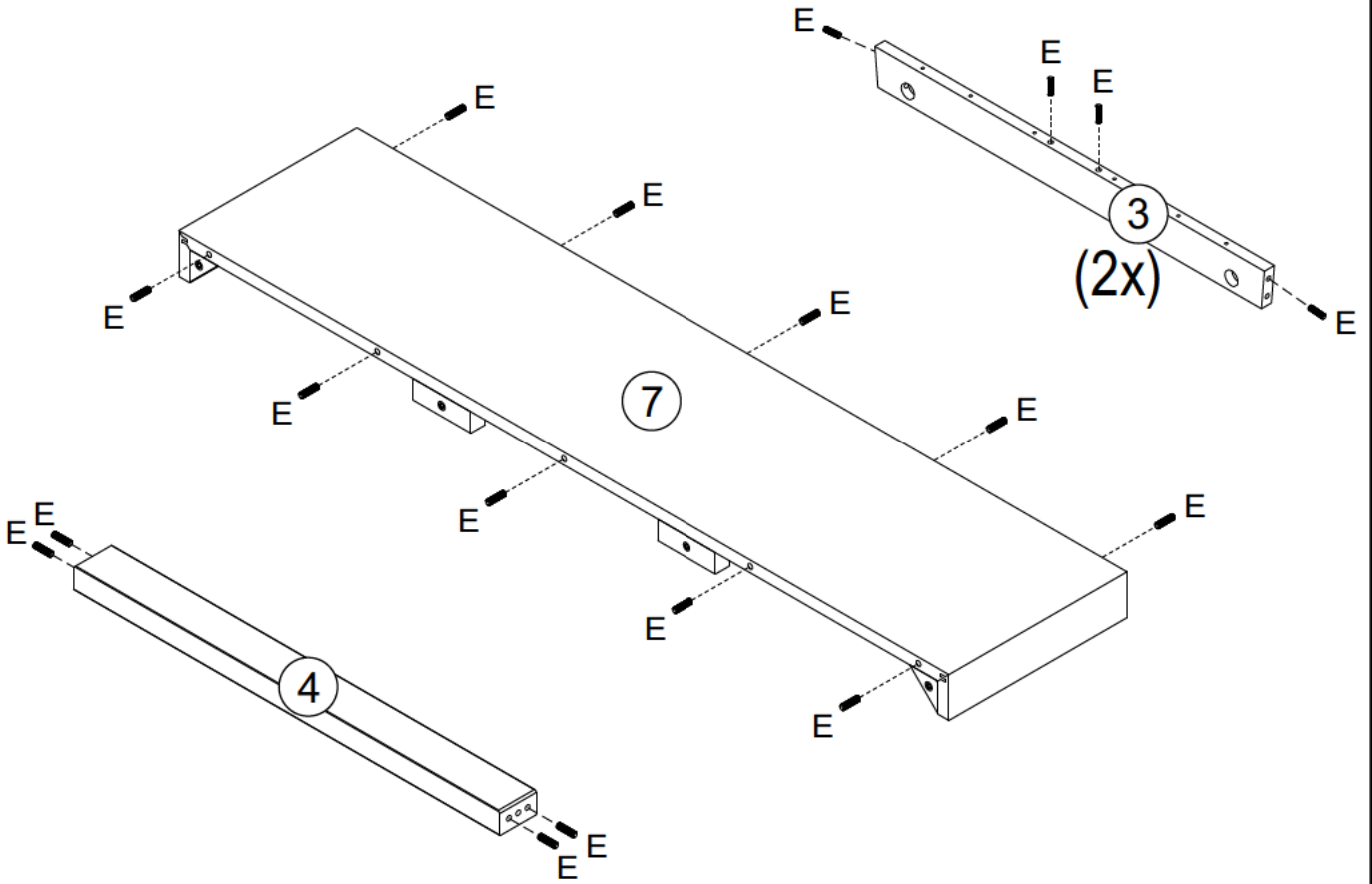

Step 2

Attach part (2) to part (1) using bolt (B) and a hex key (H). Complete this step twice.

(2x)

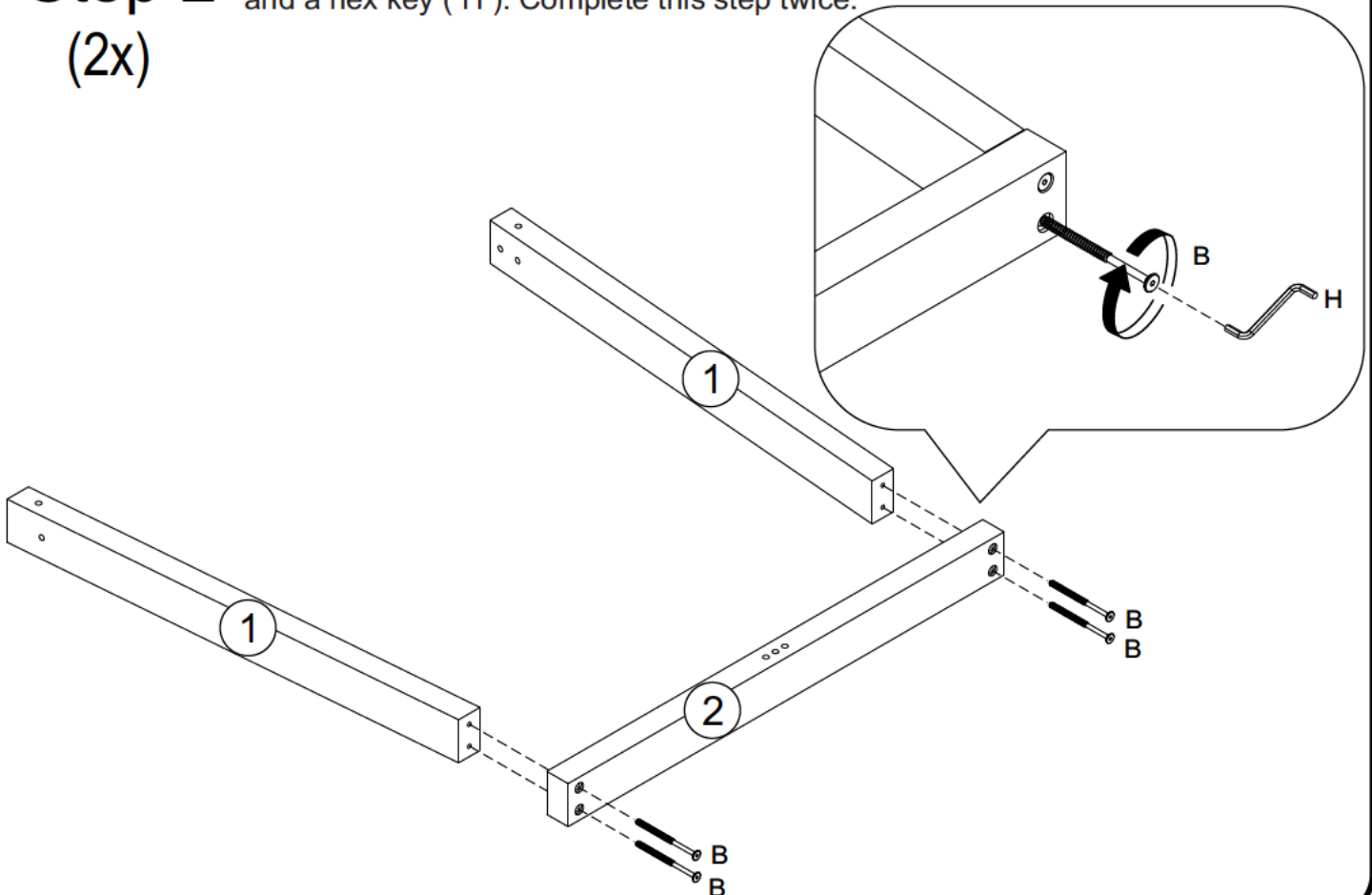

Step 3 (2x)

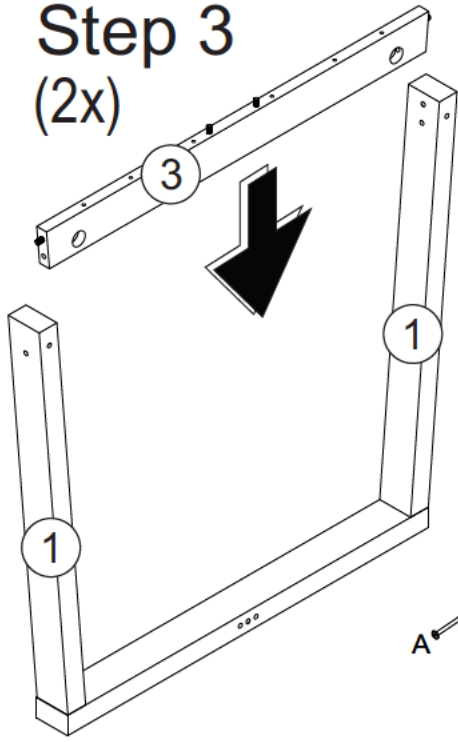

Attach part (3) to part (1) using bolt (A) with barrel nut (F) and hex key (H). Complete this step twice.

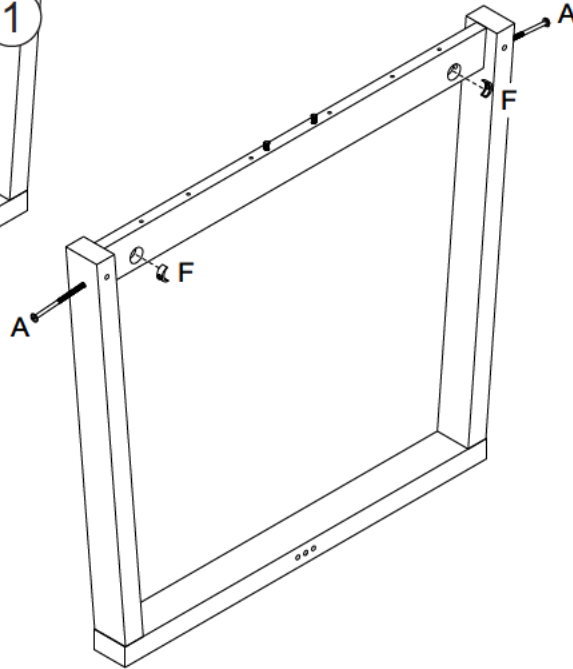

1st

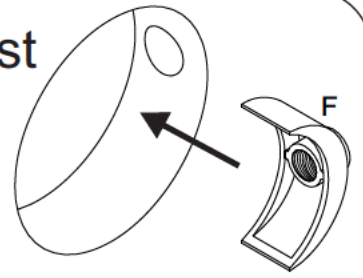

2nd

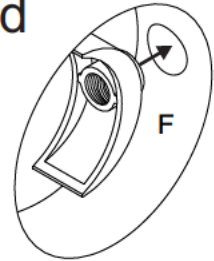

3rd

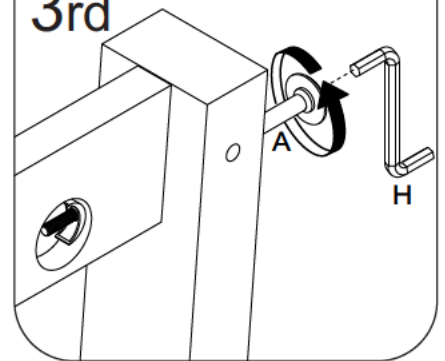

Step 4

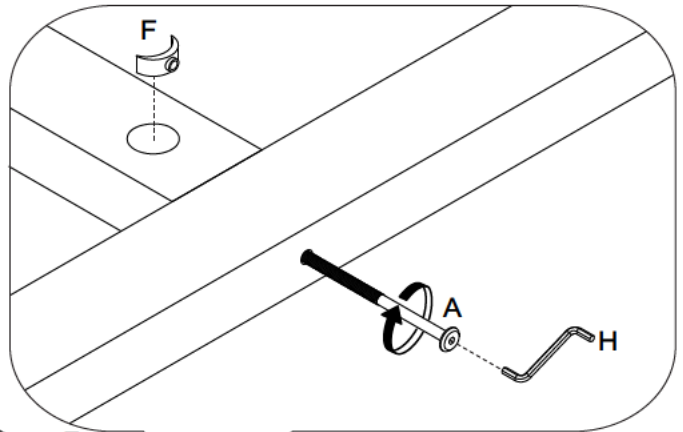
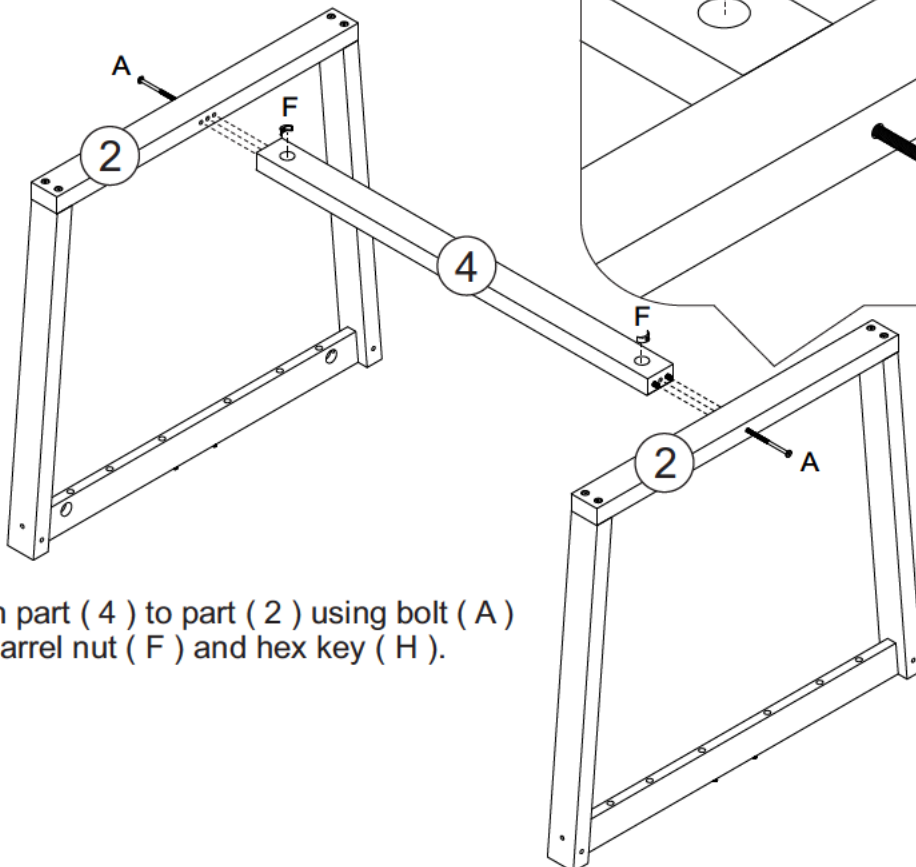

Attach part (4) to part (2) using bolt (A) with barrel nut (F) and hex key (H).

Step 5

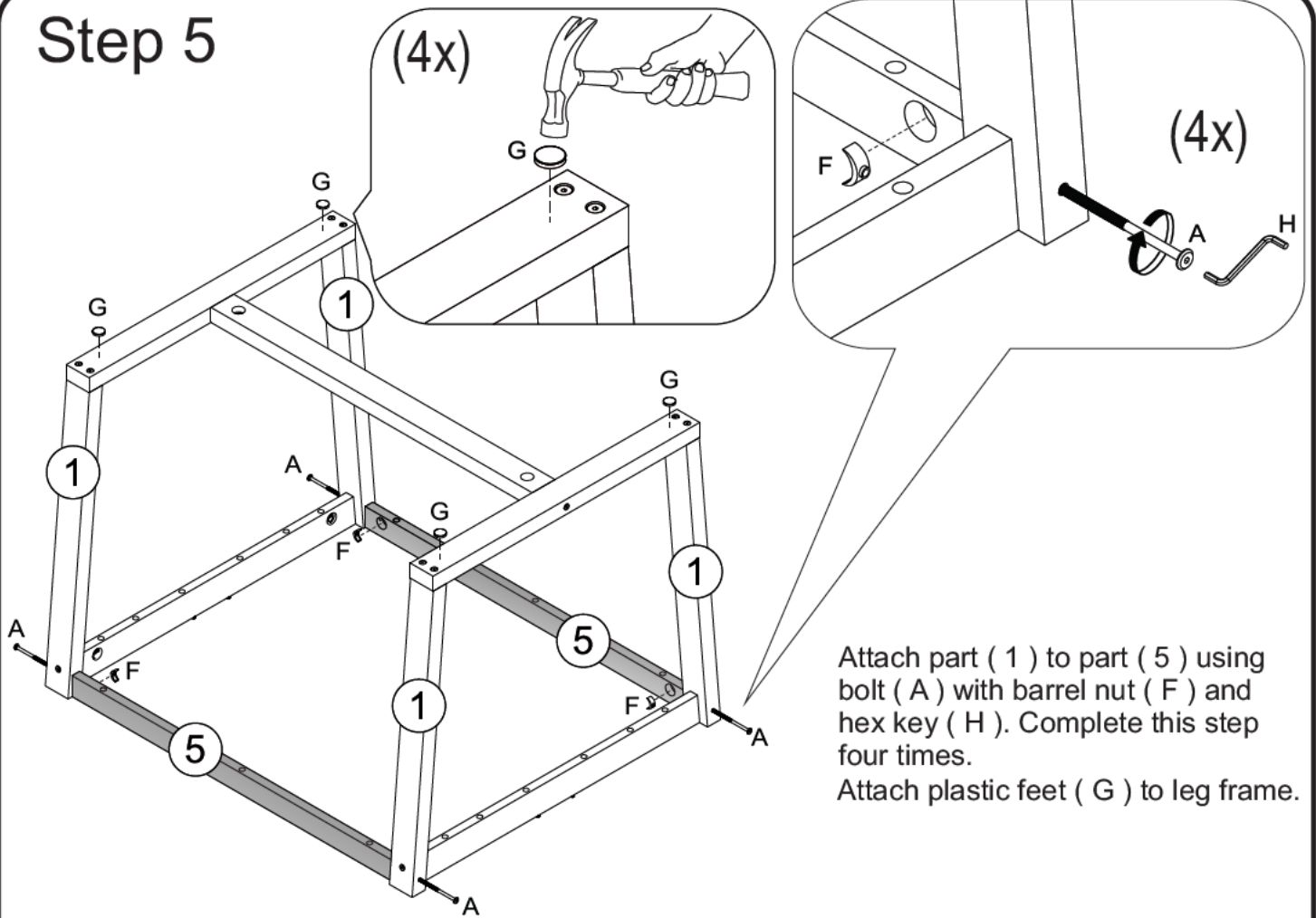

Step 6

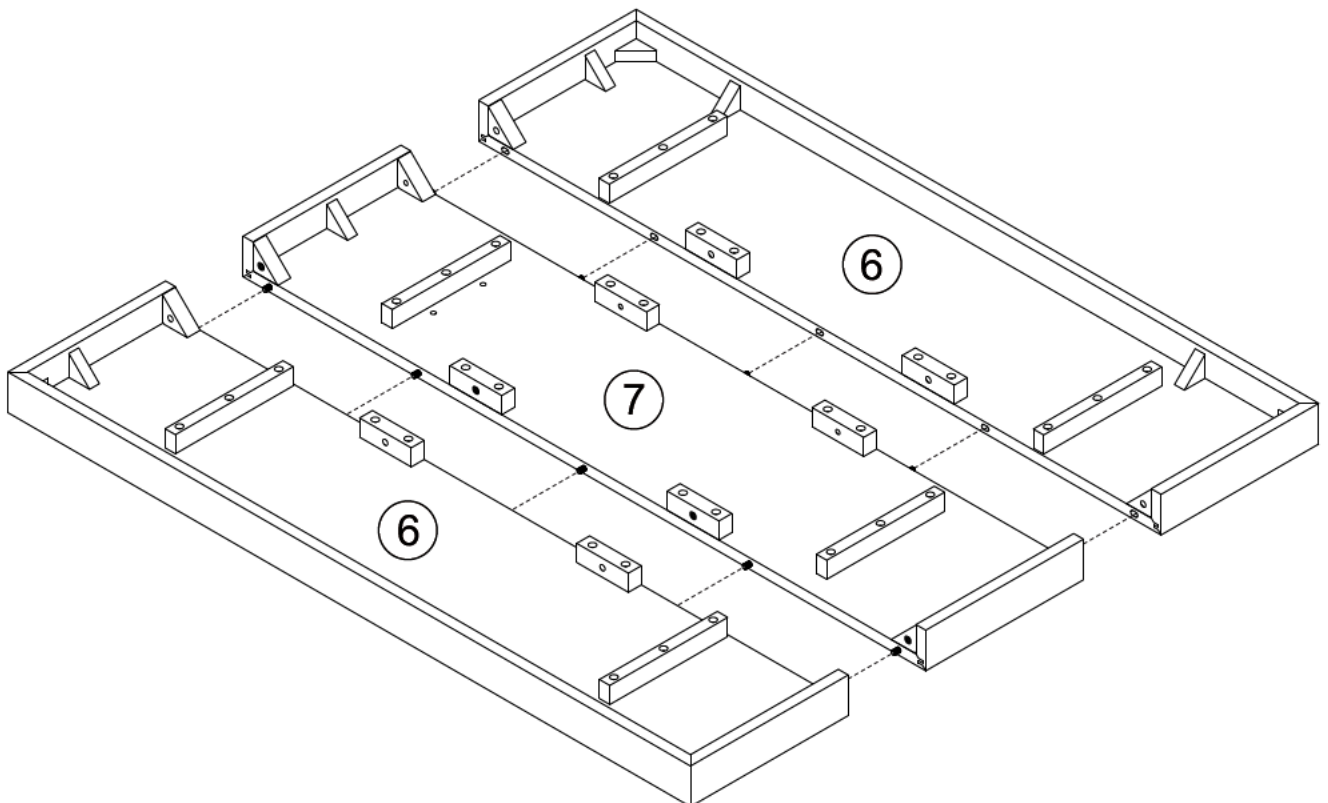

Step 7

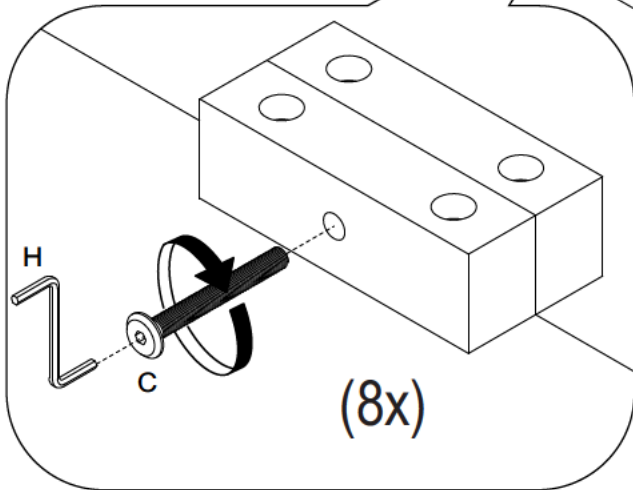
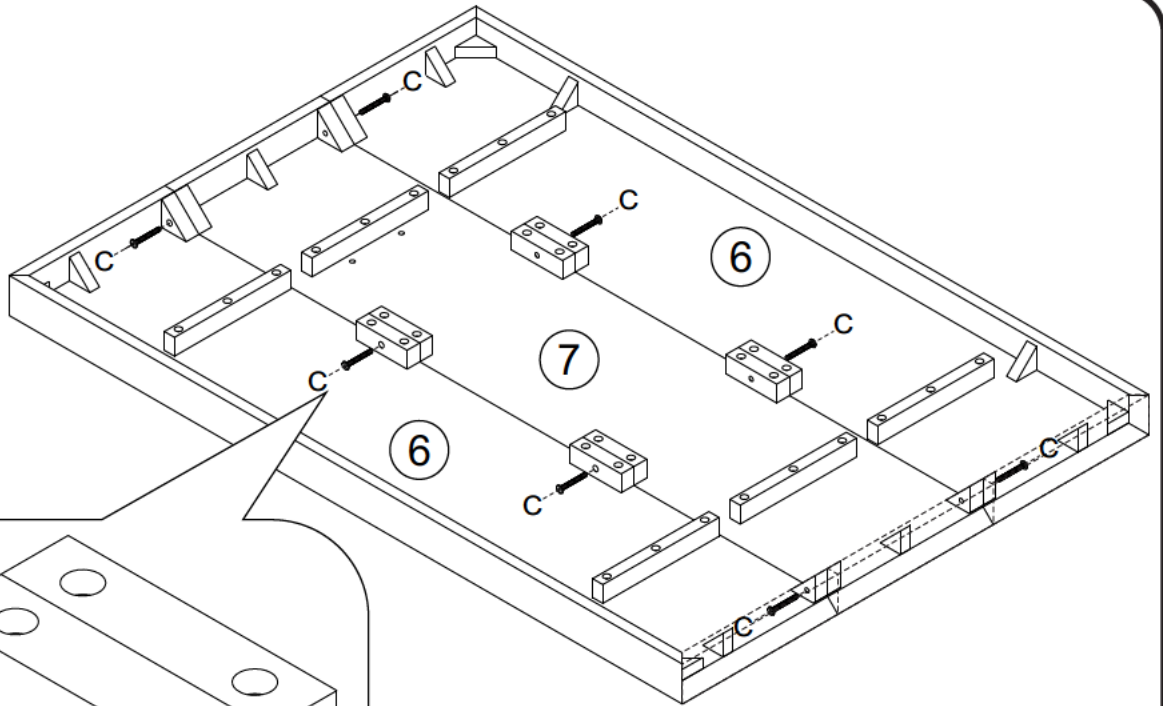

Attach part (7) to part (6).
Secure the pieces using bolt (C)
and hex key (H).

Step 8

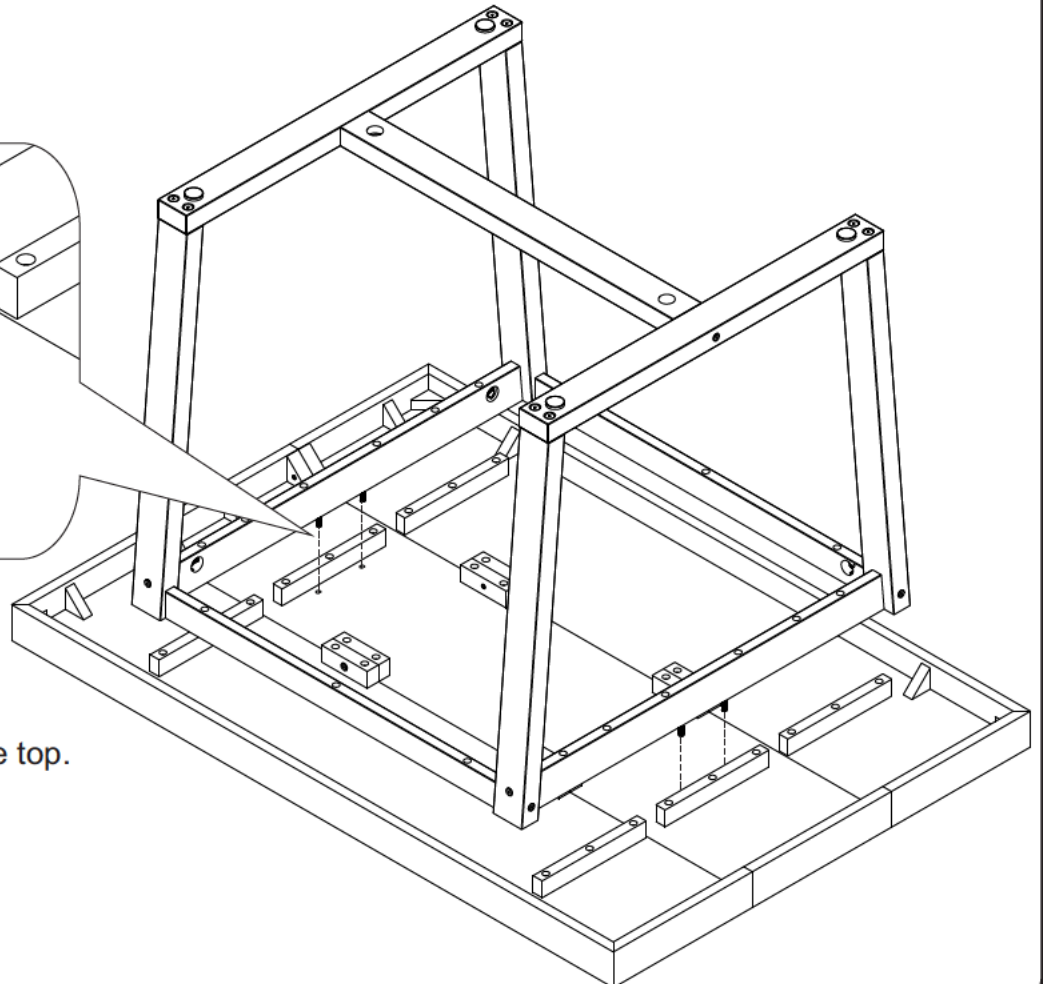
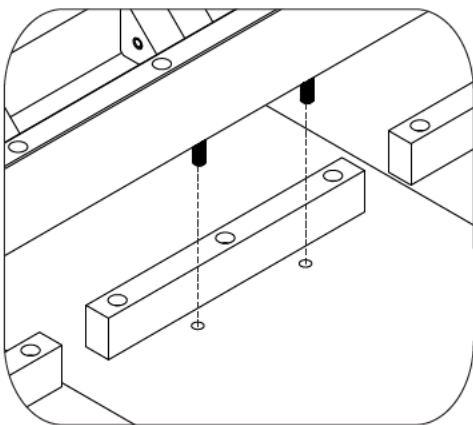

Place leg frame onto table top.

Step 9

Secure leg frame onto table top using screw (D) and a screwdriver.

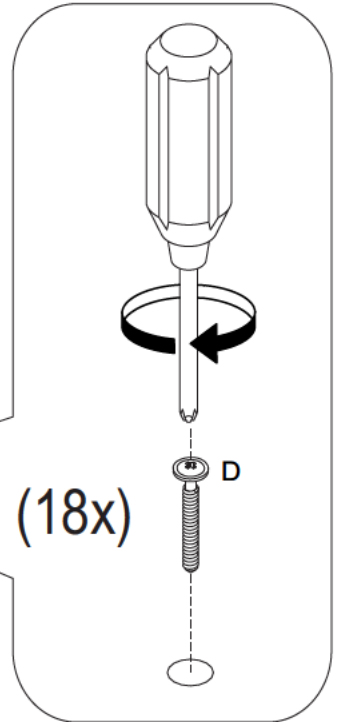
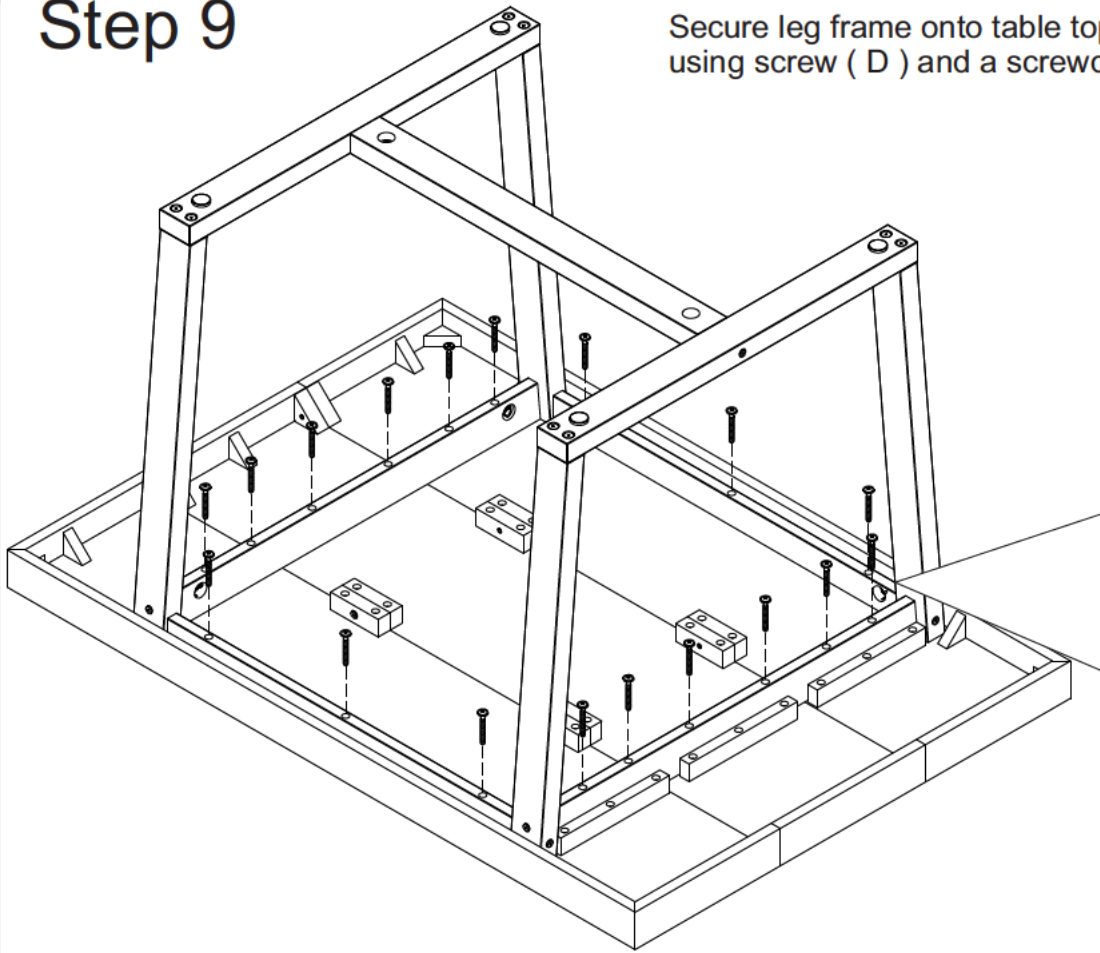

Step 10

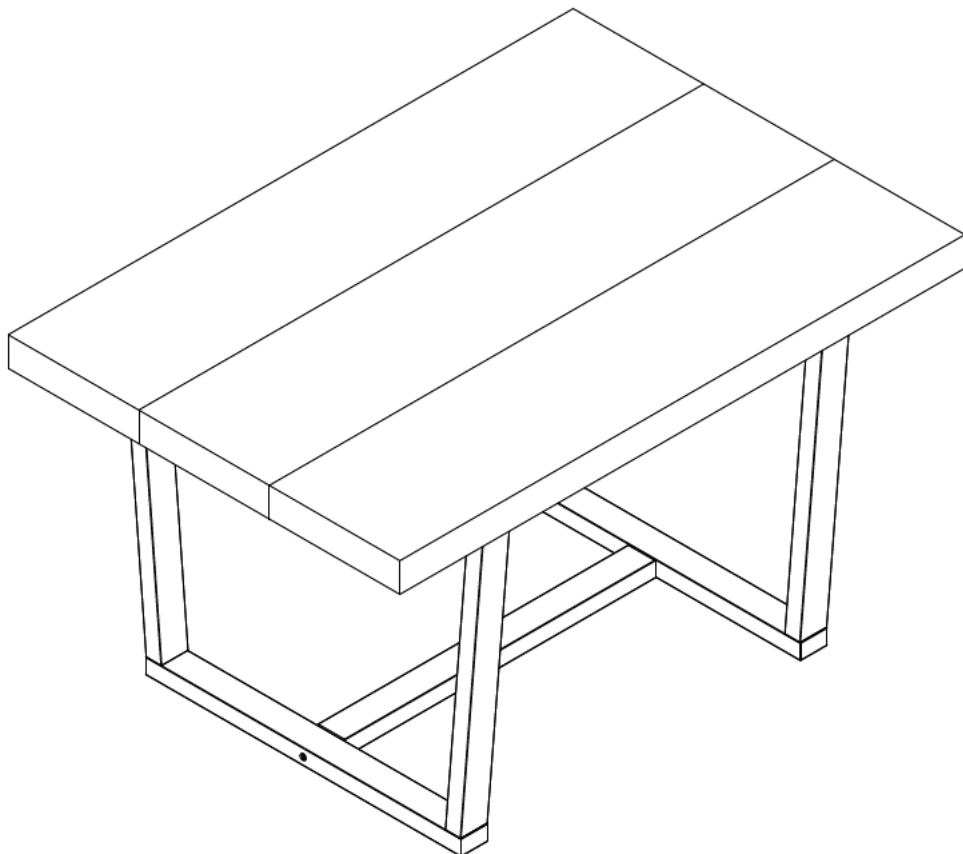

Final Assembly.