

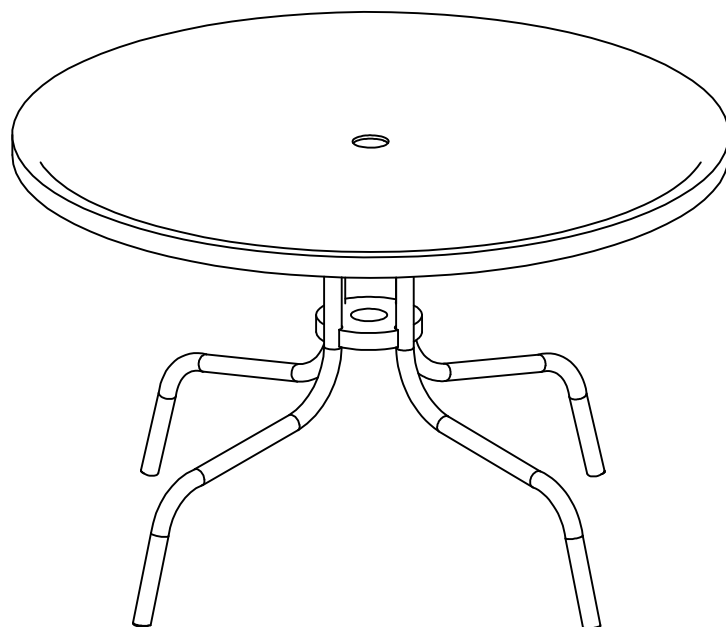

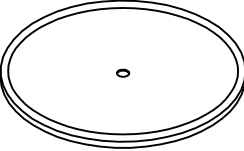



# GRIFFITH METAL PATIO TABLE



# PART LIST

<b>A</b> 	<b>B</b> 	<b>C</b> 
Top 1 PC	Leg 4 PCS	Leg Coupler 2 PCS

# HARDWARE LIST

<b>1</b> 	<b>2</b> 	<b>3</b> 	<b>4</b> 
Allen Bolt (M6x40mm) 8 PCS	Flat Washer 8 PCS	Square Nut 8 PCS	Allen Wrench 1 PC

**STEP 1** Insert Square Nuts (Part#3) into position in both of the Leg Couplers (C).

Note - Be sure that the square nuts are completely inserted to the bottom of leg coupler.

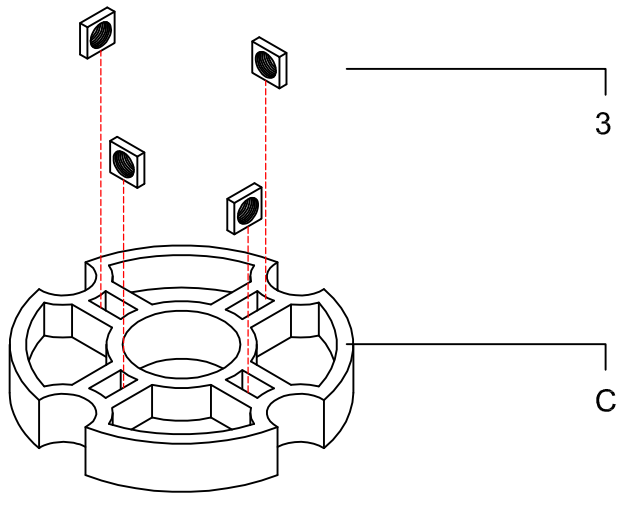

 8 PCS

**STEP 2** Attach the Leg Coupler (C) to two of the legs (B) using Allen Bolts (Part#1) & Flat Washers (Part#2) as shown.

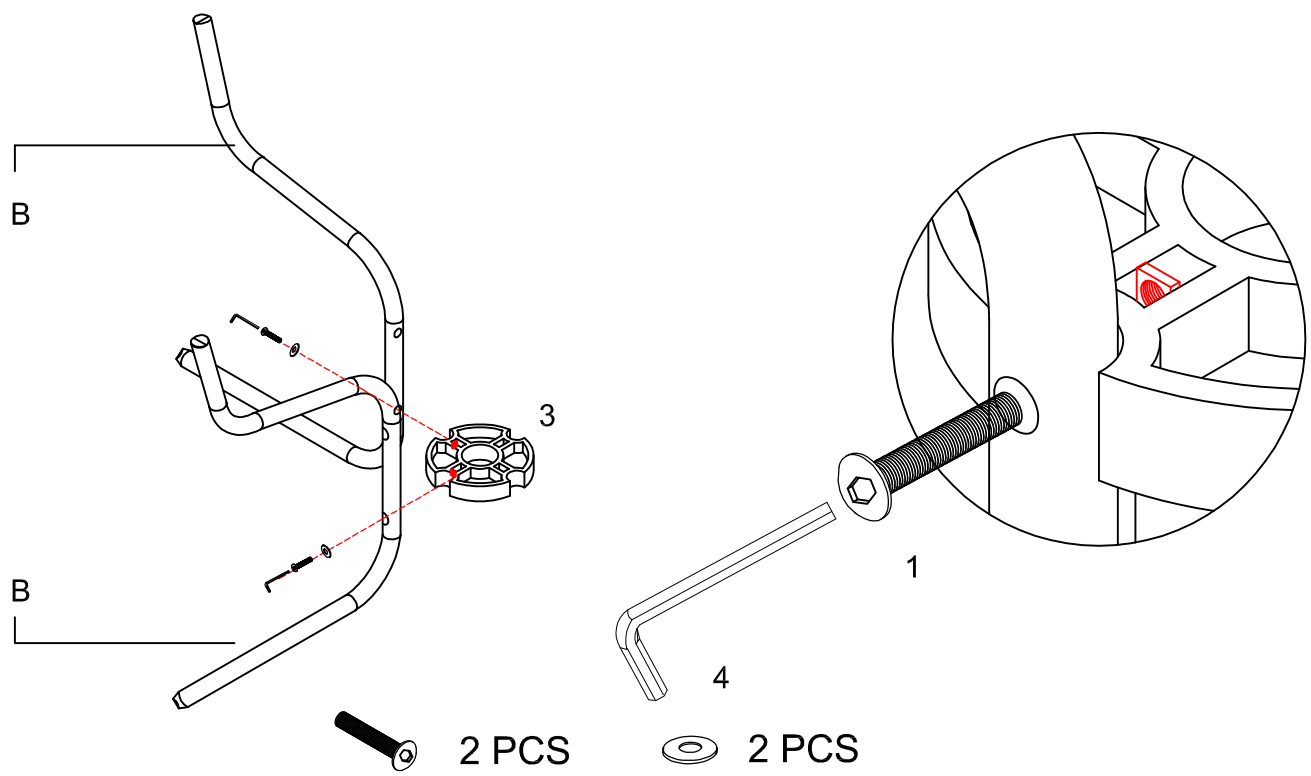

**STEP 3**

Lay the Top (A) on a flat surface with the bottom lip facing up. Fit the flat ends of the legs under the lip of Top (A) aligning the hole of the Leg Coupler (C) with the hole in Top (A).

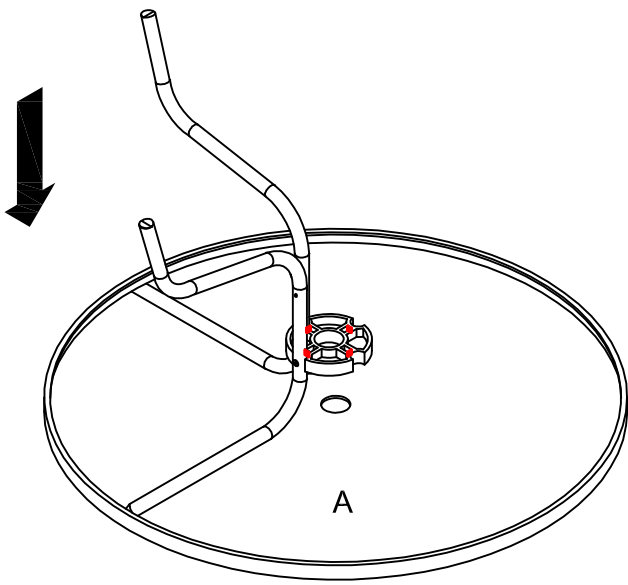

**STEP 4**

Add a third Leg (B) fitting the flat end under the lip of Top (A) and attach using an Allen Bolt (Part#1) and Flat Washer (Part#2) as shown.

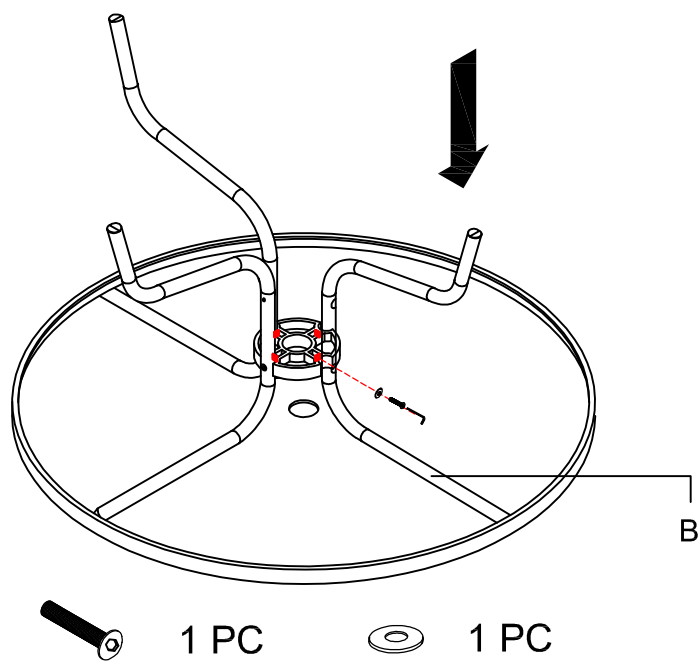

**STEP 5** Attach the second Leg Coupler (C) to the three Legs (B) using Allen Bolts (Part#1) & Flat Washers (Part#2) as shown.

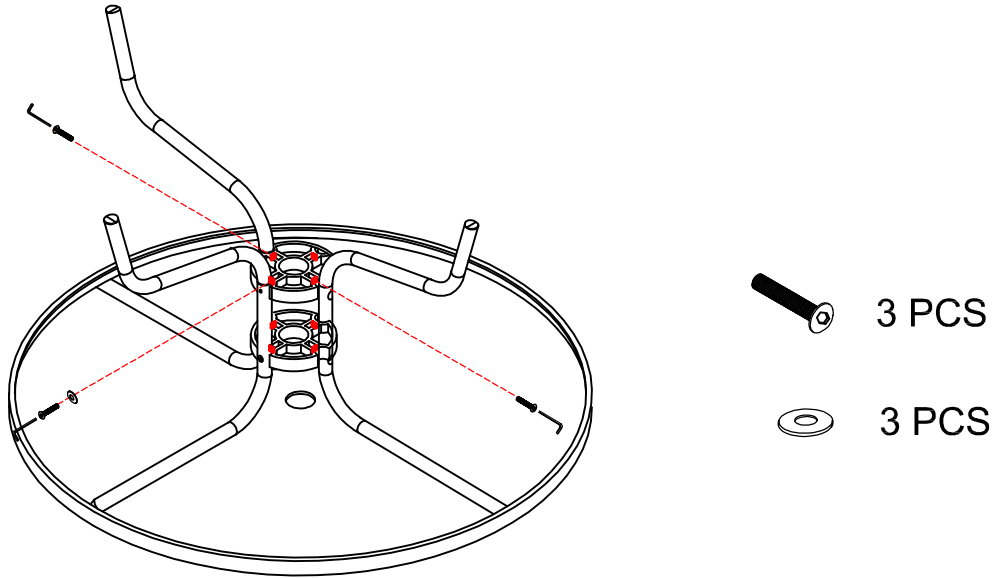

**STEP 6** Add the fourth Leg (B) by fitting the flat end of the leg under the lip of the table and positioning the portion with the bolt holes into the Leg Coupler (C).

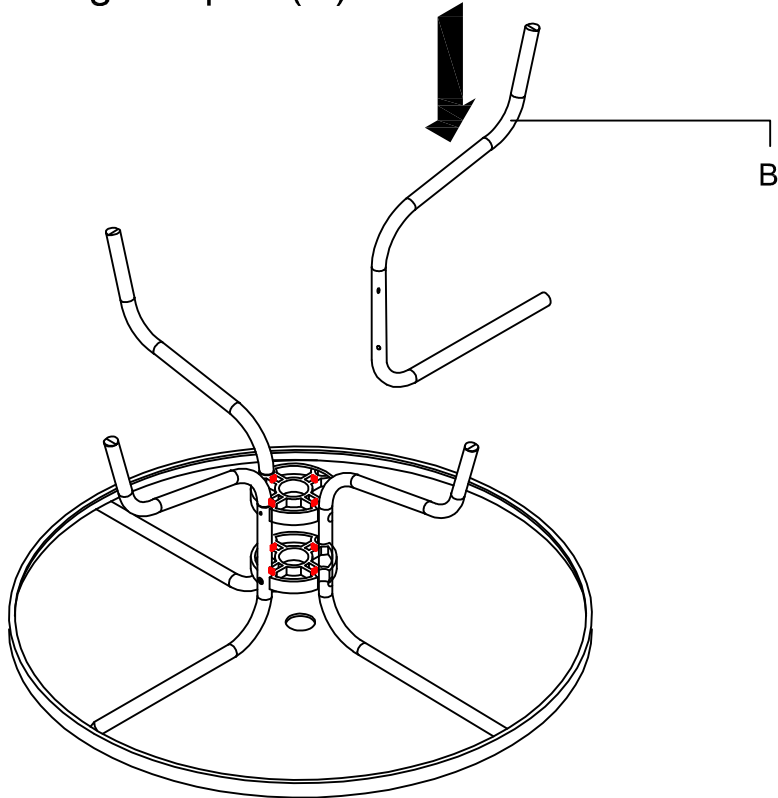

**STEP 7**

Attach the fourth Leg (B) to the Leg Coupler (C) using Allen Bolts (Part#1) and Flat Washers (Part#2) as shown.

Note - Be sure that the legs are aligned at 90 degree angles before tightening the fourth leg completely.

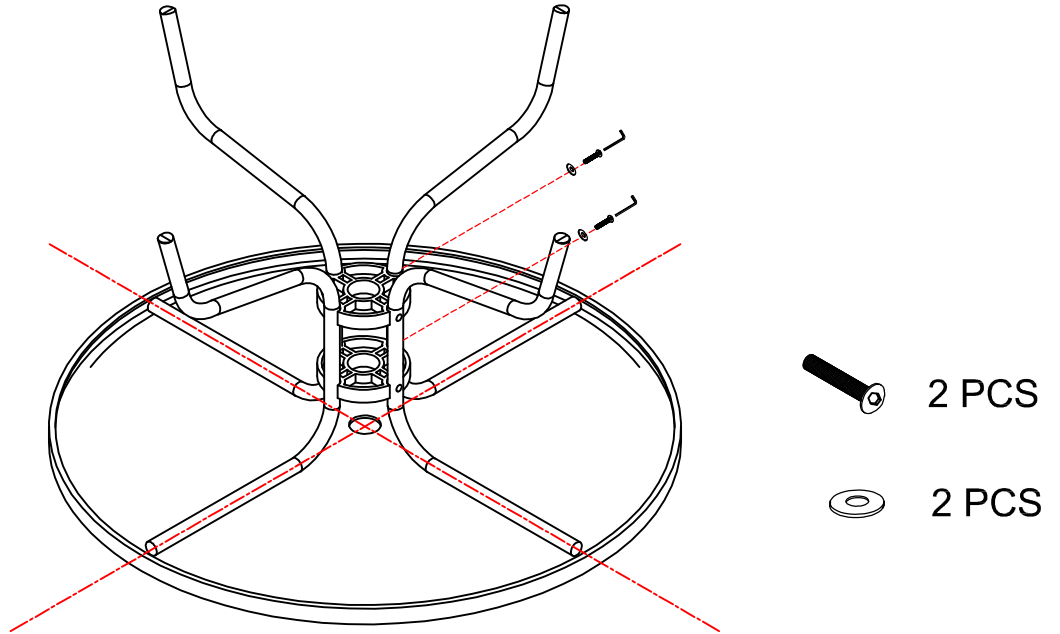

**STEP 8**

Turn the table over on a flat surface.

