

**OFE022 OFE023 OFE024**  
**OFE025 OFE026 OFE027**

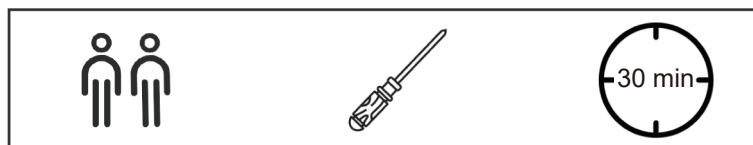

Any questions please contact us  
[service@replycenter.net](mailto:service@replycenter.net)



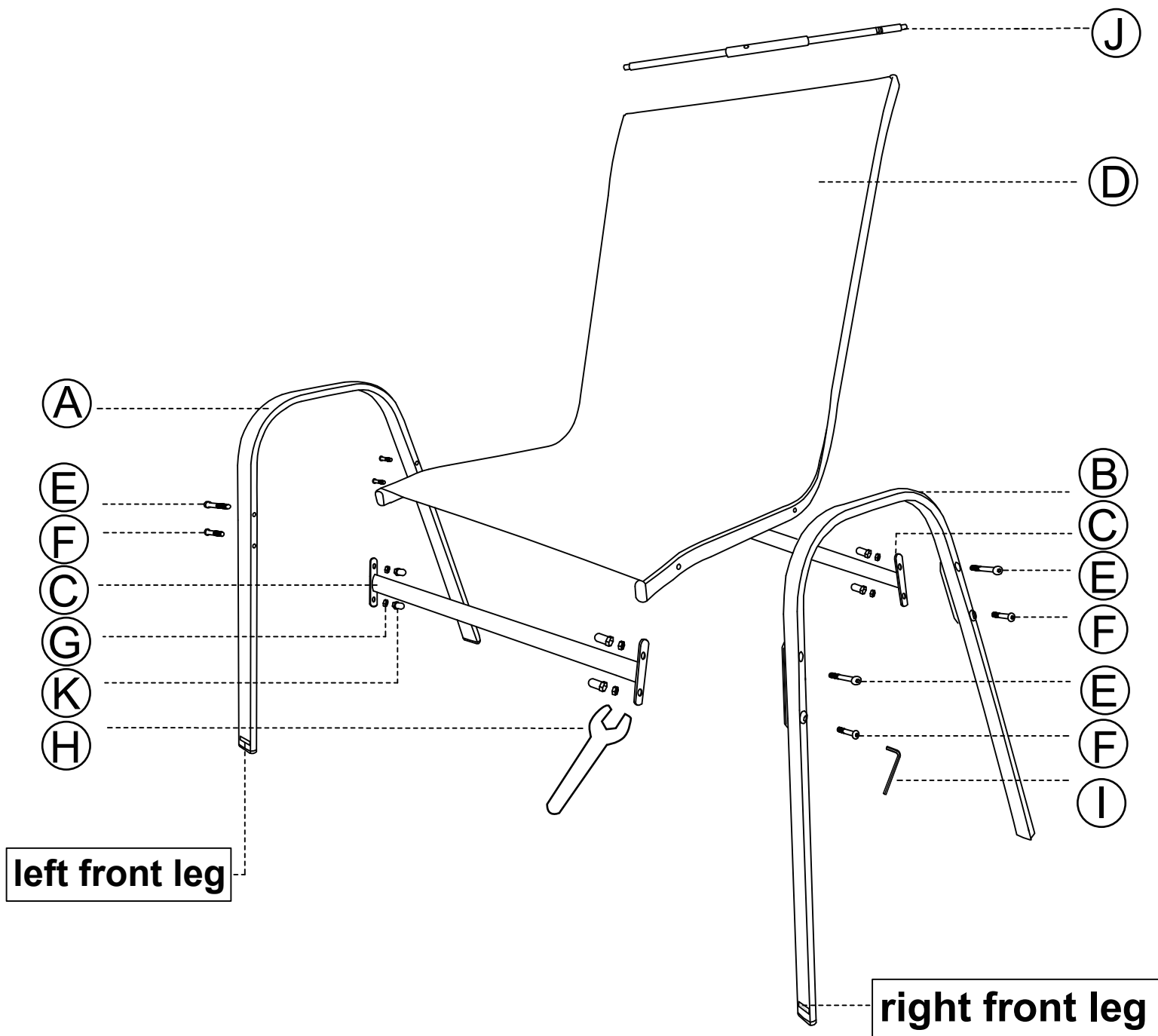

Read this instruction carefully. Refer hardware and furniture parts list for guidance. Be sure all parts are complete before assembling. Place all wooden furniture part on a clean and flat soft surface to prevent scratches. Refer steps provided as assembling guide.

# EXPLODED DRAWING:

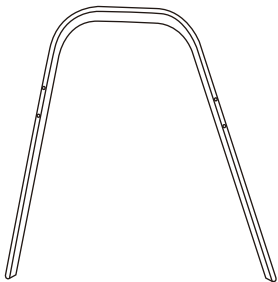

**NOTE!!!** Please ensure you follow these instructions carefully during installation. It's crucial NOT to completely tighten the screws initially. Wait until STEP8 is finished before tightening all screws.

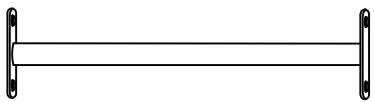
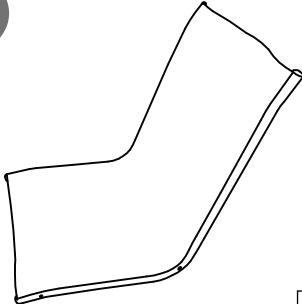
# ACCESSORY LIST

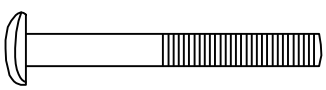
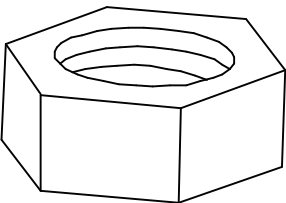
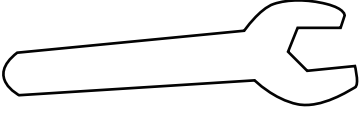
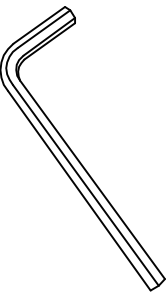
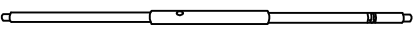
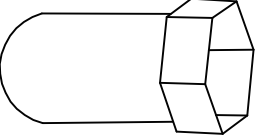
<p><b>A</b></p>  <p>left front leg</p> <p>x 1</p>	<p><b>B</b></p>  <p>right front leg</p> <p>x 1</p>	<p><b>C</b></p>  <p>x 2</p>
<p><b>D</b></p>  <p>x 1</p>	<p><b>E</b></p>  <p>4pcs 70mm</p> <p>x 4</p>	<p><b>F</b></p>  <p>4pcs 55mm</p> <p>x 4</p>
<p><b>G</b></p>  <p>x 8</p>	<p><b>H</b></p>  <p>x 1</p>	<p><b>I</b></p>  <p>x 1</p>
<p><b>J</b></p>  <p>x 1</p>	<p><b>K</b></p>  <p>x 8</p>	

# STEP

1

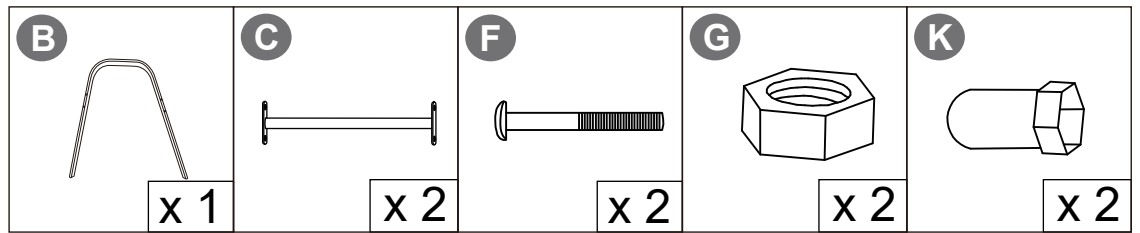

Attach the right side of support beam (C) to the Right Leg (B) first. Use screws (F), nuts (G) and parts (K) to connect them.

**Note!** There are 2 holes on the support beam (C), you just need to connect the bottom hole of the (C) first.

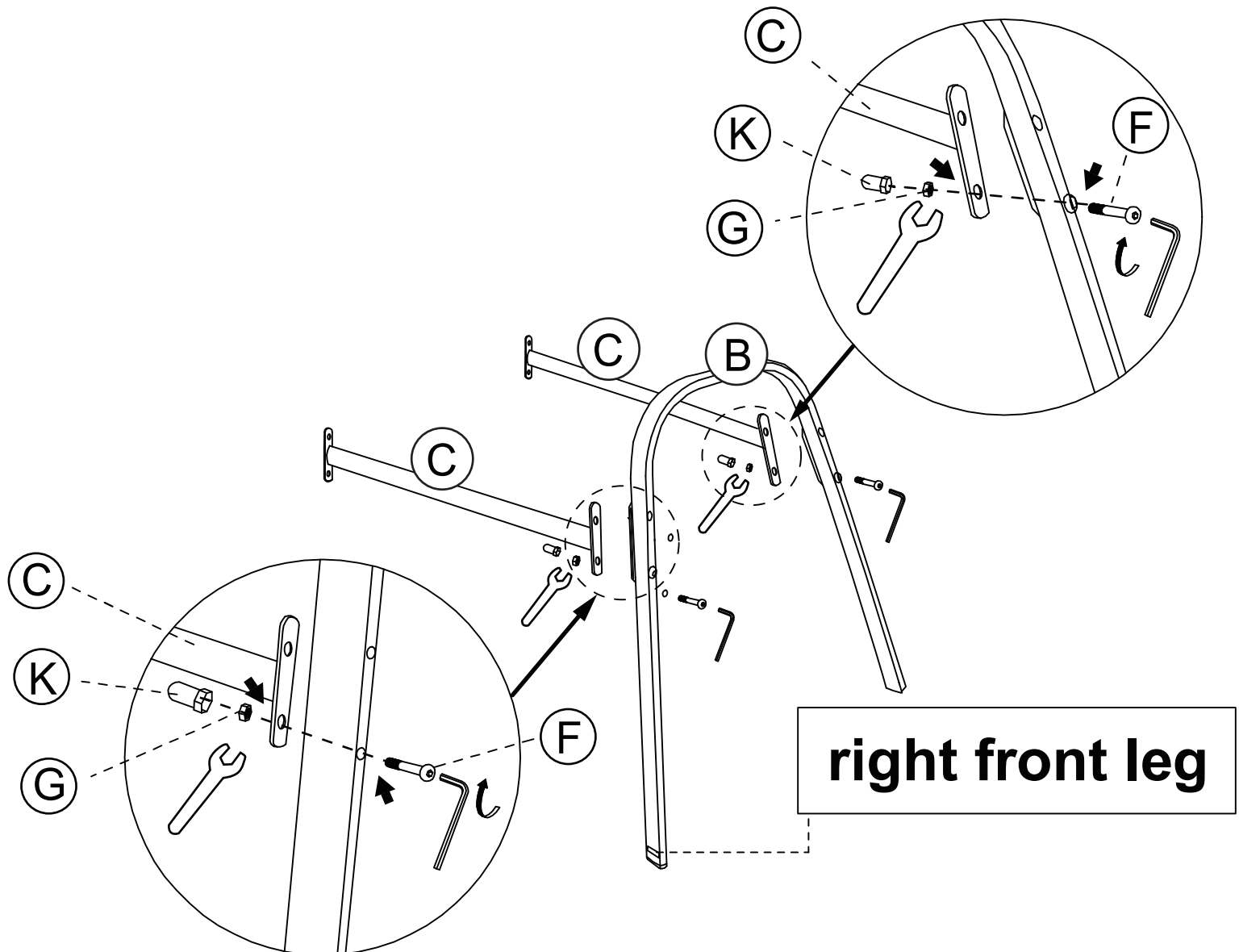

# STEP

2

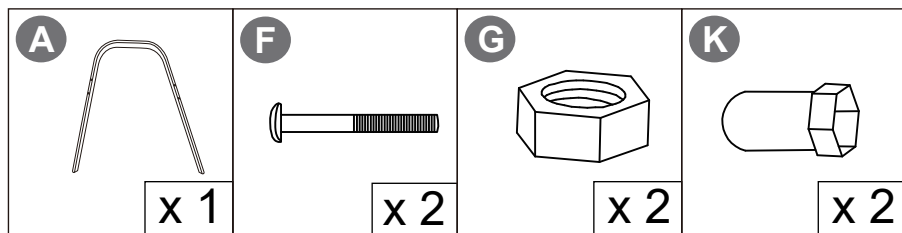

After attach the right side of 2 support beams (C) to Right Leg (B), please attach the left side of 2 support beams (C) to Left Leg (A). Use screws (F), nuts (G), parts (K) to connect them.

**Note!** There are 2 holes on the support beam (C), you just need to connect the bottom hole of the (C) first.

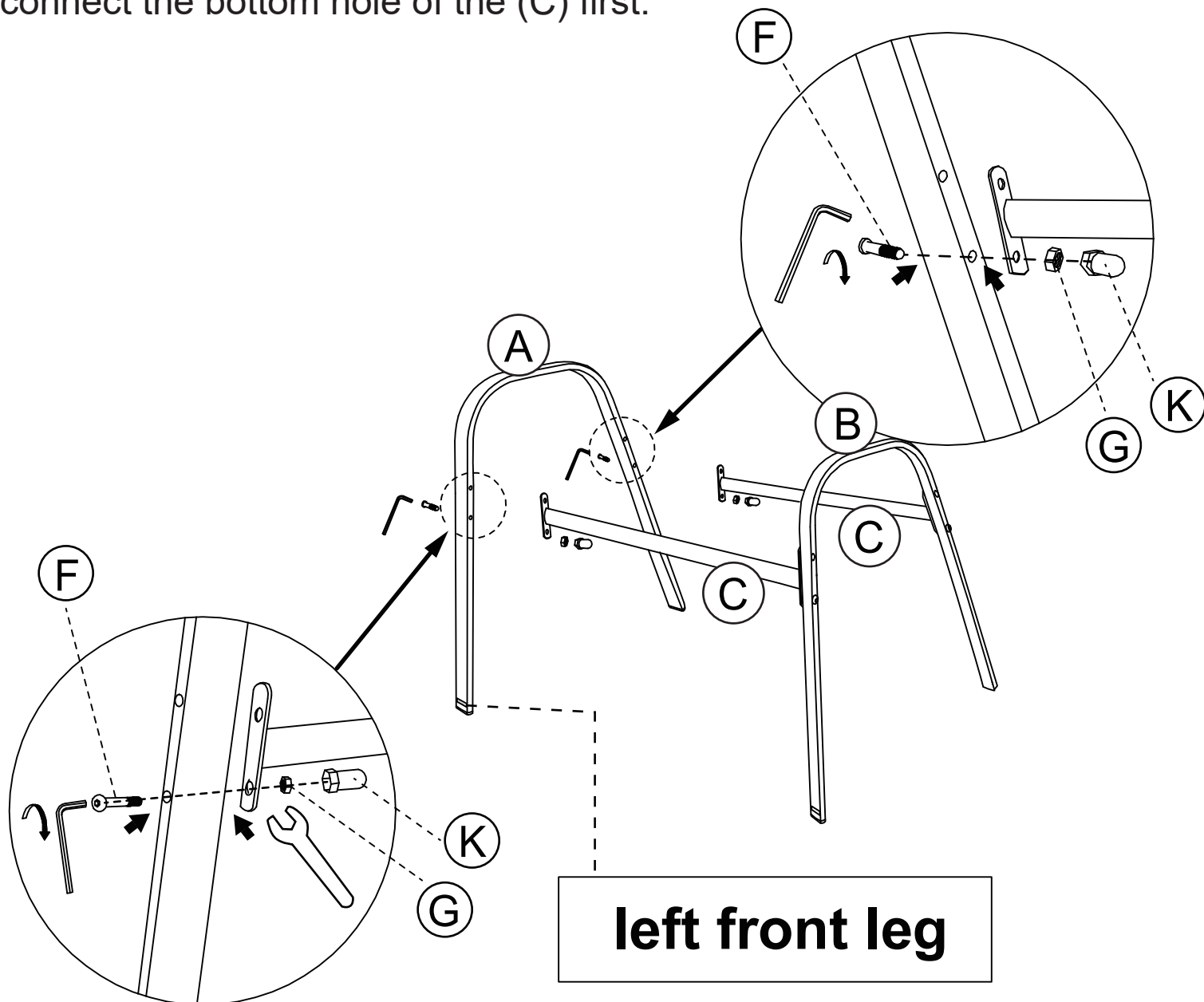

# STEP

3

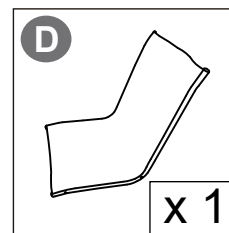

Unfold Part (D) and make it at the correct direction before install it to the chair frame.

**Note!** If the Part (D) is correctly unfolded, you will only see two holes on the side of the Part (D). Please check it before installing.

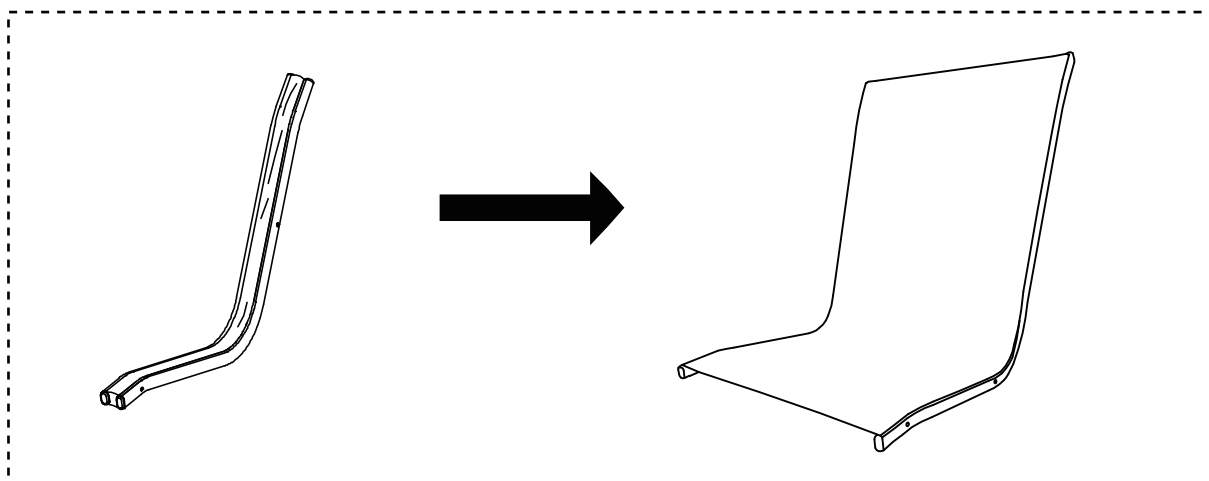

**A** If the Part (D) is correctly unfolded, you will only see two holes on the side of the Part (D).

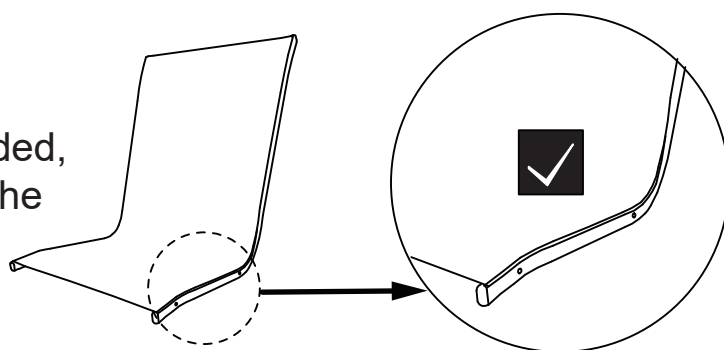

**B** If the Part (D) is unfolded uncorrect, you will see three holes on the side of the Part (D).

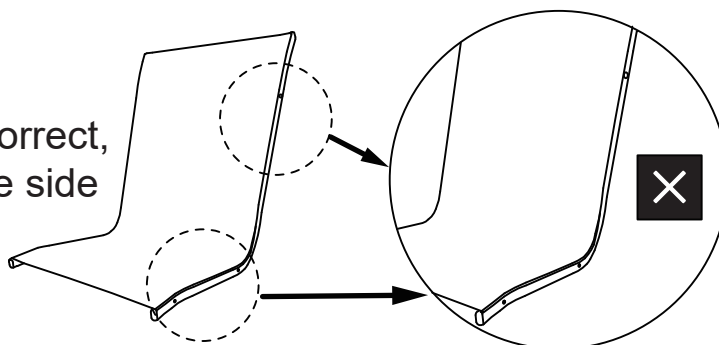

# STEP

4

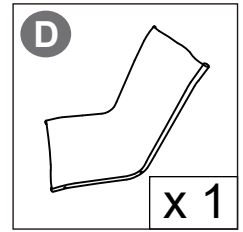

Make sure you place the the part (D) on the chair frame at the correct direction. Align the holes of part (D) to the top holes of the support beam (C).

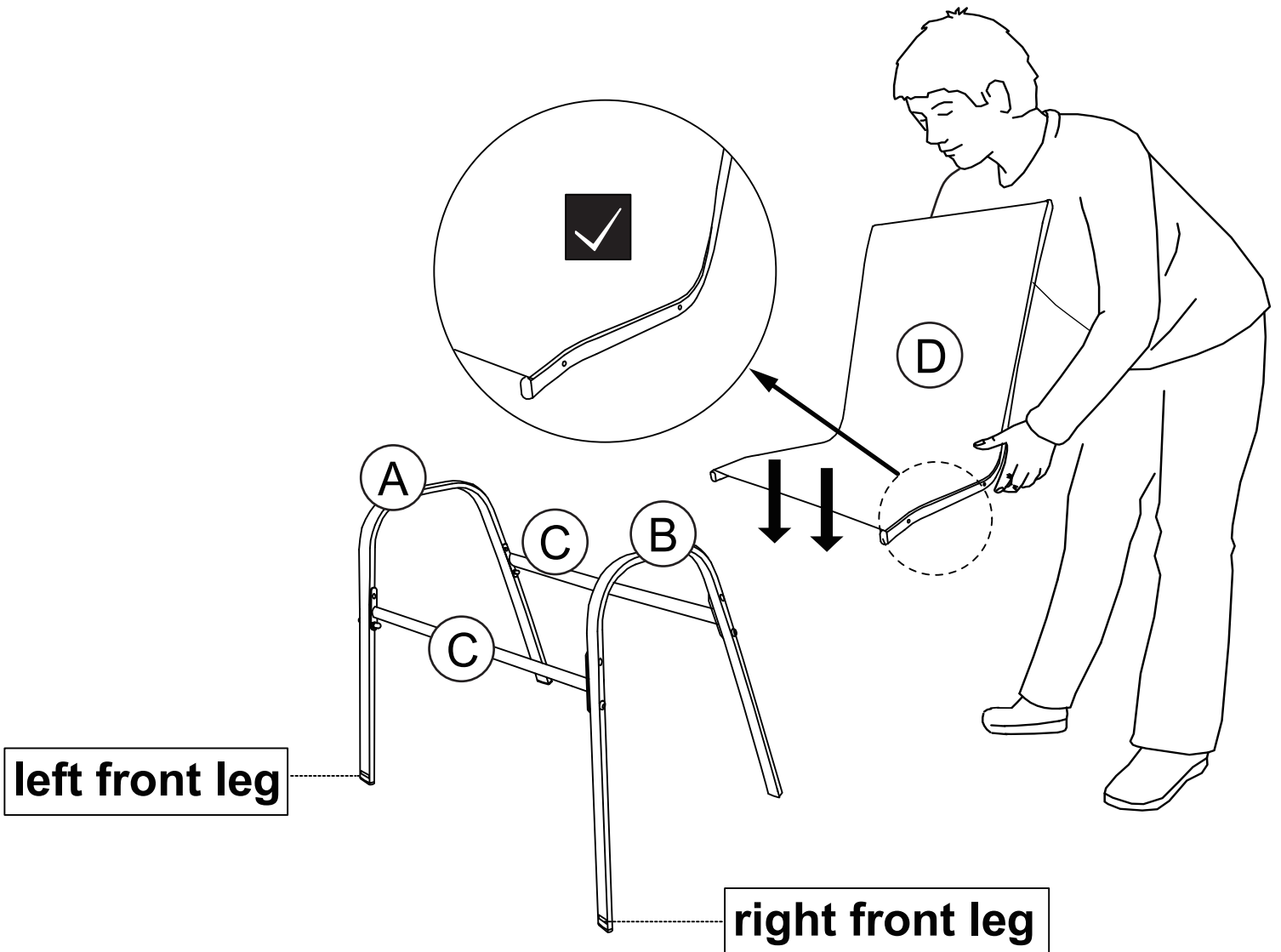

# STEP

5

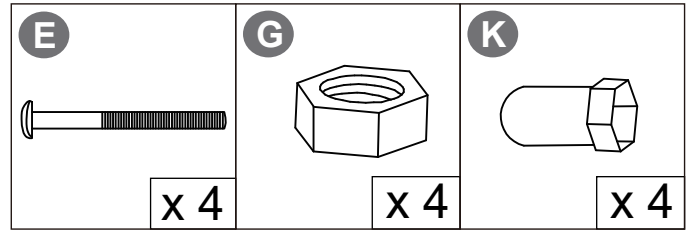

Use screws (E) and nuts (G) and parts (K) to connect part (D) to the metal frame. After this step, you can tighten each screw.

**Note!** There are 2 holes on the support beam (C), you just need to connect the top hole of the support beam (C) first.

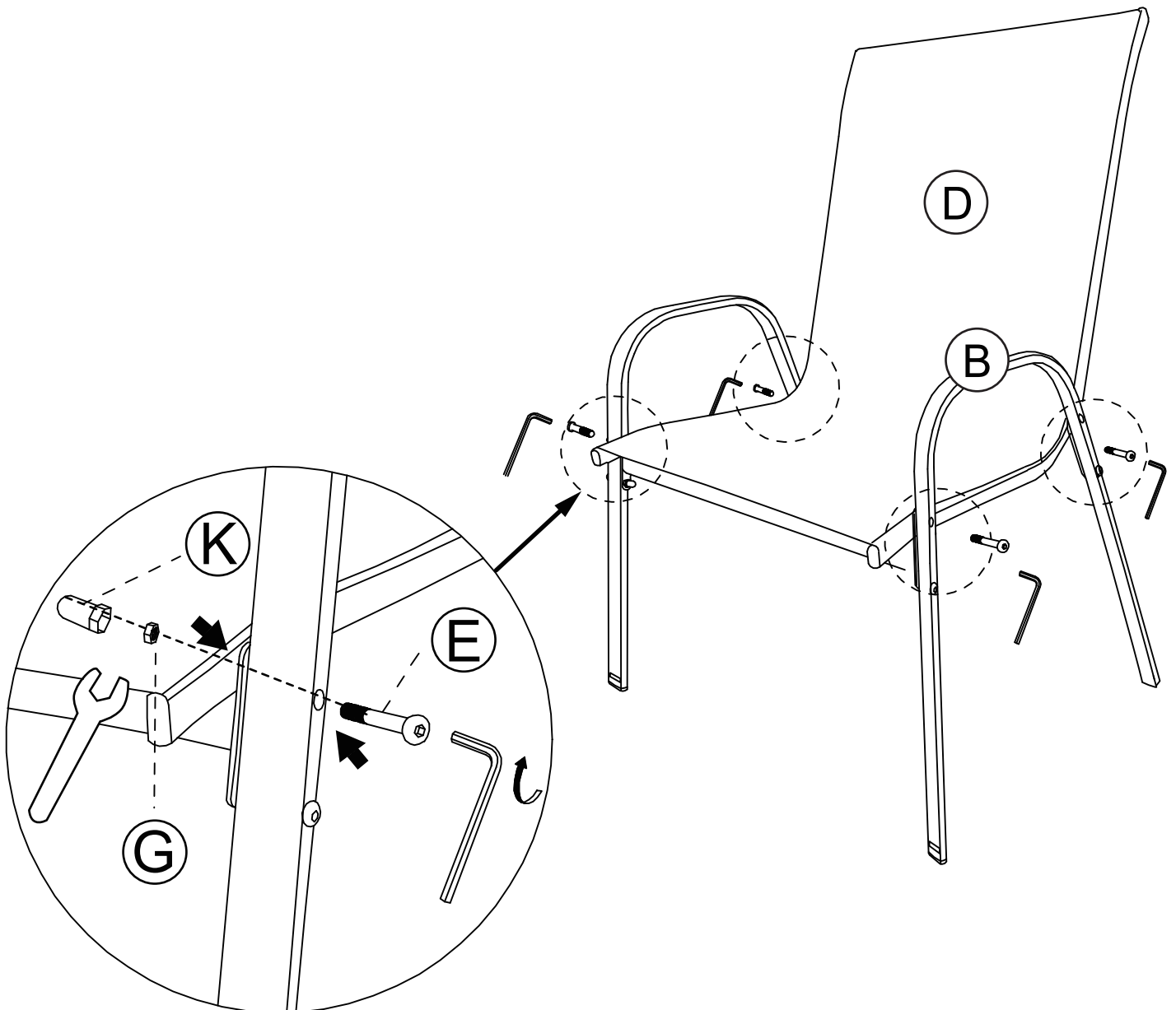

# STEP

6

First insert the left side of Part (J) into the Part (D). Then insert the right side of Part (J) into the Part (D).

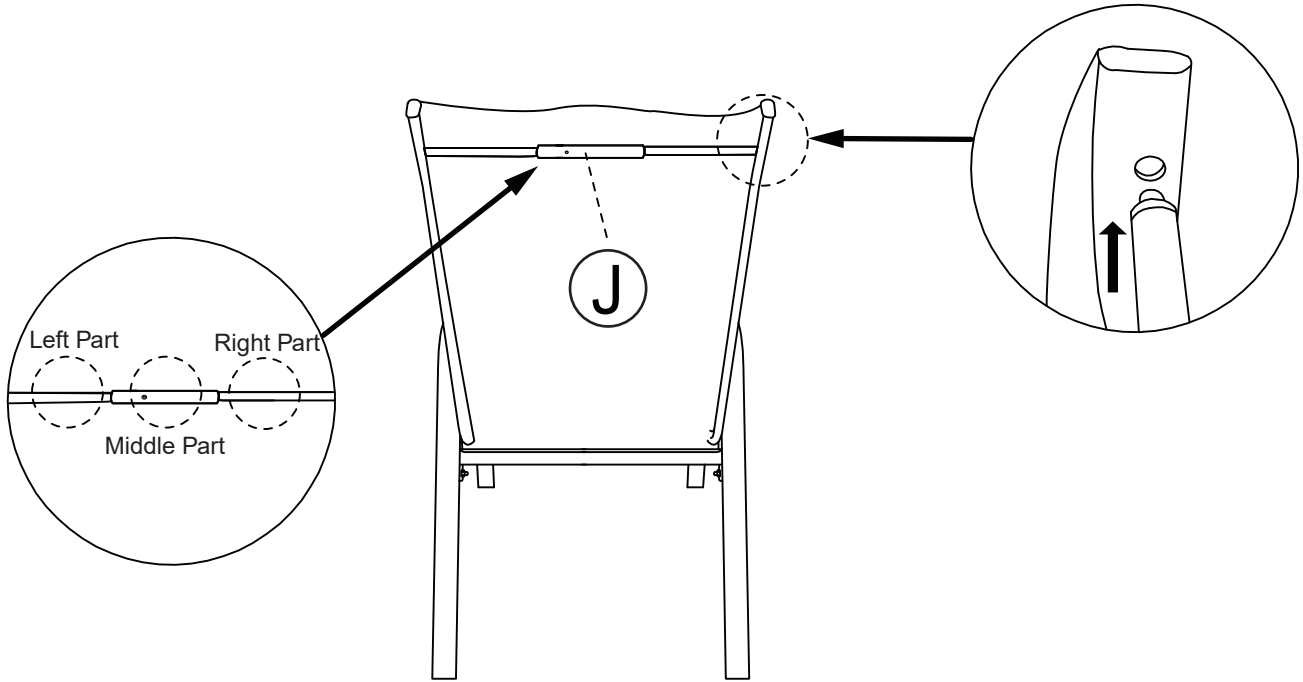
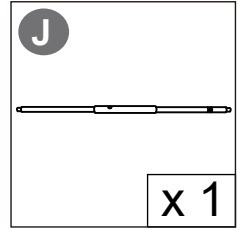

7

Hold the middle part of the Part (J) and rotate the right part of it by clockwise until the seat back is fully extended.

**Note!** You don't need to rotate Part (J) to the end, you can stop when the seat back is flat.

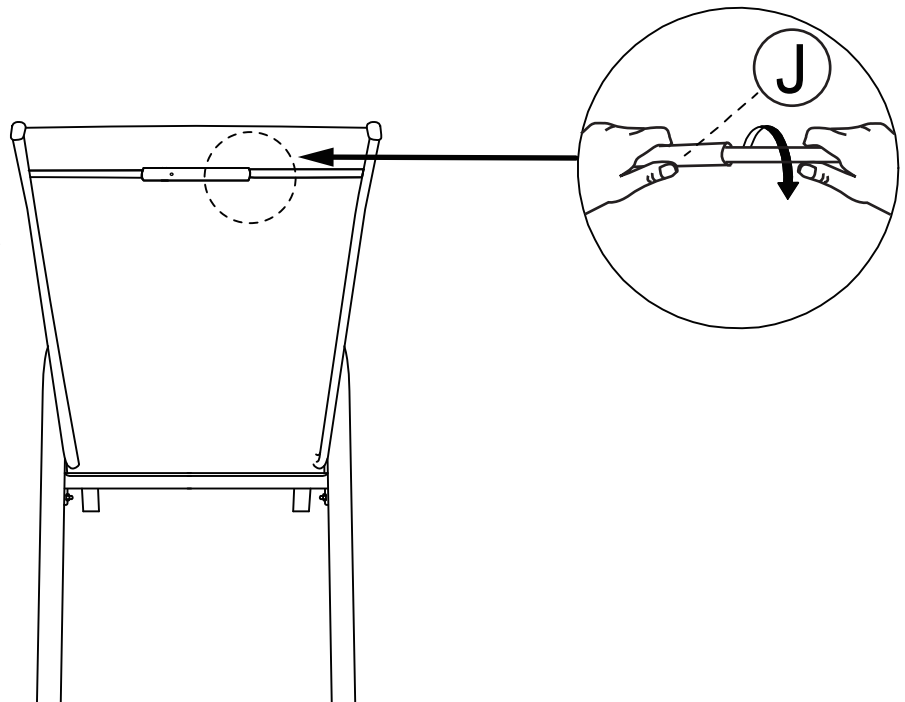

# STEP

---

---

8

Tighten all the screws and nuts.

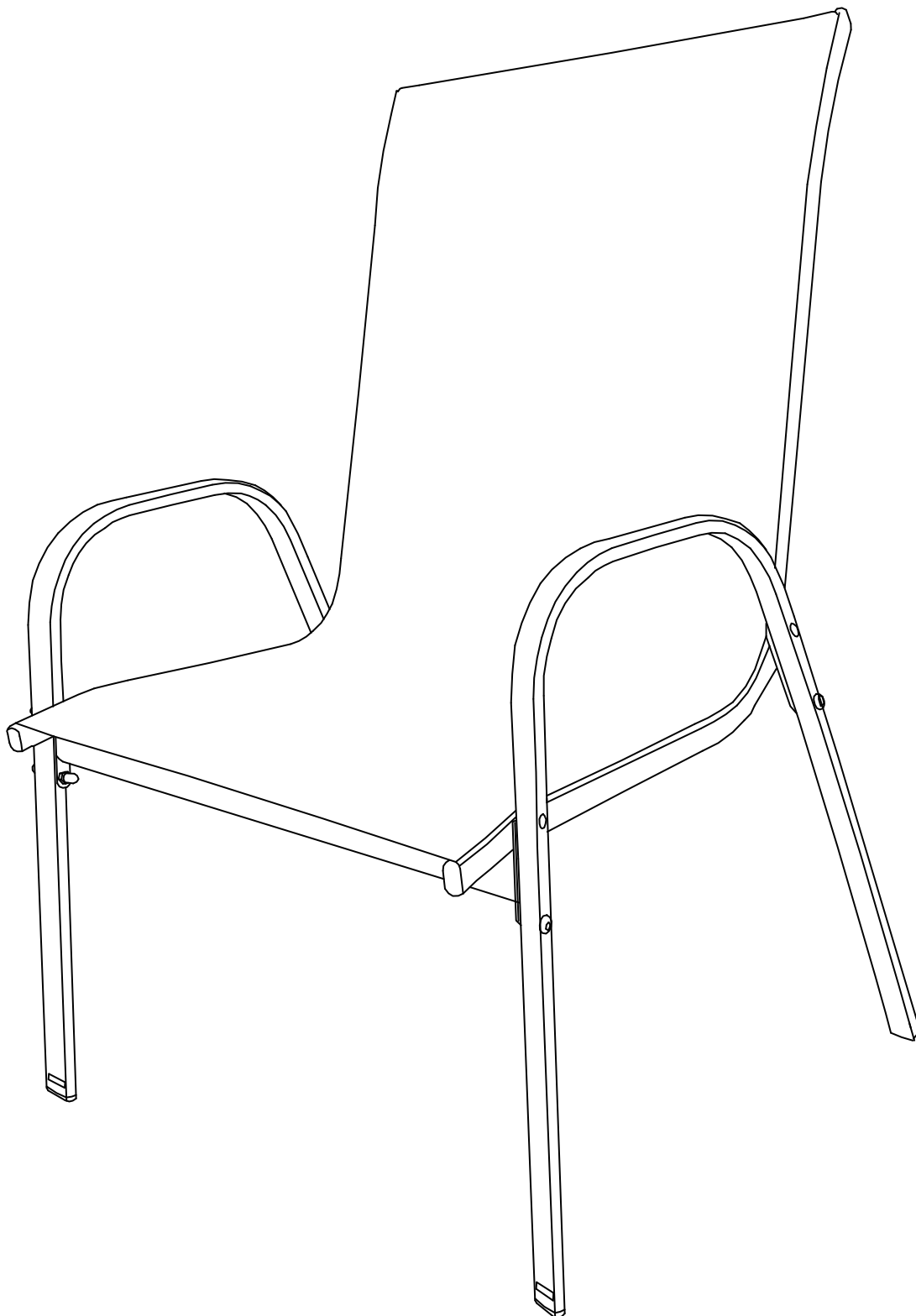

# CUSTOMER SERVICE FAQs

---

---

Q: The chair is unstable and wobbly after installation.

A: If you find that the chair is unstable and wobbly after installation, please review steps 1 and 2 of the installation.

Q: Some parts are missing, I could not finish assembly.

A: Please kindly circle missing parts in the parts list of the manual, and send pictures to our service team.

We will prepare and ship them to you for free ASAP.

Q: My item occurs a quality problem. I am not satisfied with it.

A: Please kindly take it easy and provide us pictures.

We would help you to solve it by send replacement parts, replacement products or refund. And you do not need to take time to repack and return it back to us.

Q: The color is not the same as I ordered. How to solve it?

A: Please kindly help to provide us the pictures of the SKU number, the shipping label on the carton and also the product itself, better in one picture. Your pictures will help us to speed up solving the problem.

Q: How to prolong the service life of this item?

A: When it is stained with dusts, oil or sweat, please wipe with a damp cloth. You'd better use a cover when it is out of use.

# AFTER-SALE

---

---

## AFTER-SALE SERVICE

If you have any suggestions for our products or find that the products have quality problems, please contact us first, our after-sales team will reply you within 24 hours, and we will do our best to give you solutions until you are satisfied.

### Guaranteed Customer Service

Your shopping experience is very important to us!

Feel unsatisfied? **Contact us!**

Have any questions? **Contact us!**

Wanna share your experience with our products?

Share your pictures with us.

Any suggestions? **Contact us!**

We gotcha back!



E-mail: [service@replycenter.net](mailto:service@replycenter.net)