

# ASSEMBLY INSTRUCTIONS

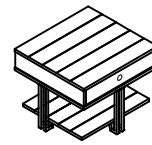

954-915

## TOOLS REQUIRED:

Allen Wrench (supplied, Part # D)

## BEFORE YOU START:

1. Check the hardware against the hardware list to make sure all items are present.
2. Assemble your furniture on a soft, flat surface to avoid scratching the finish.
3. **CAUTION:** Do not over tighten screws, nuts or bolts during assembly.
4. Your furniture may require occasional tightening.

## INSTRUCTIONS:

1. Turn the top upside down on a clean soft surface. As Shown in Figure 1.
2. Attach the three legs to the top panel using Flat Washer (A), Lock Washer (B) and Bolt (C), tighten with the Allen Wrench (D). As Shown in Figure 1.  
(Do not over tighten bolts during assembly.)
3. Attach the shelf to the three legs using Flat Washer (A), Lock Washer (B) and Bolt (C), tighten with the Allen Wrench (D). As Shown in Figure 2.  
(Do not over tighten bolts during assembly.)
4. Repeat steps 2,3 for the fourth leg. As shown in Figure 3.
5. Tighten all bolts before setting table back upright.

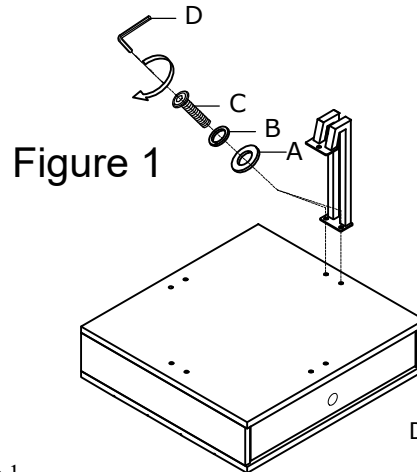

Figure 1

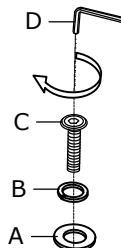

Figure 2

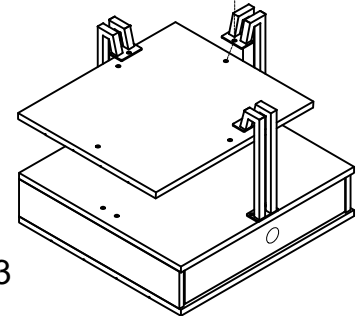
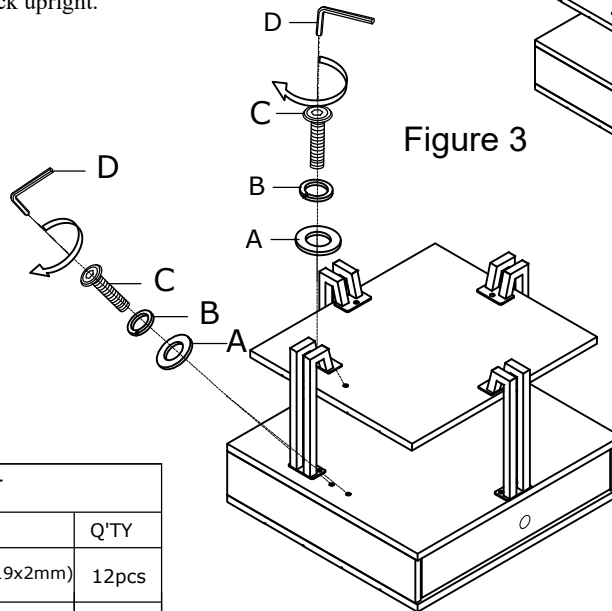

Figure 3



HARDWARE LIST			
NO.	Drawing	Description	Q'TY
A		Flat Washer (Ø5/16 "x19x2mm)	12pcs
B		Lock Washer (Ø5/16 "x13mm)	12pcs
C		Allen Bolt (Ø5/16 "x3/4")	12pcs
D		4mm Allen Wrench	1pc