

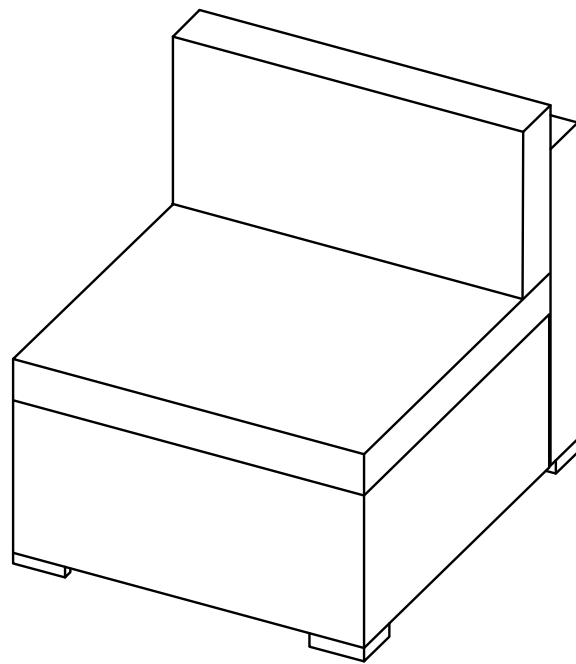

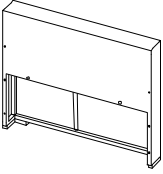

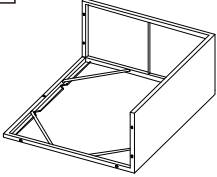

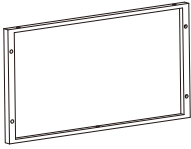

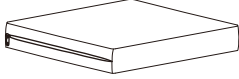

Outdoor Wicker Armless Chair



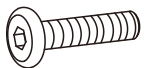
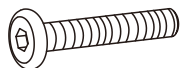
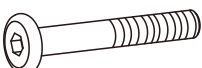

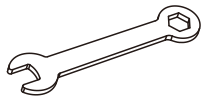

PART LIST

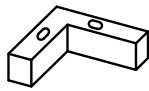
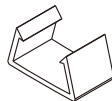
A 	B 	C 	E 	F 
Back Panel 1 PC	Seat Panel 1 PC	Side Panel 1 PC	Cover of Seat Cushion * 1 PC	Core of Seat Cushion 1 PC
G 	H 	*Please note cushion covers will ship separately.		
Cover of Back Cushion * 1 PC	Core of Back Cushion 1 PC			

HARDWARE LIST

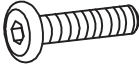
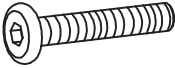
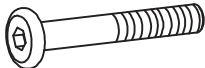
#1 	#2 	#3 	#4 	#5 
M6*30mm Short Bolt 3 PCS	M6*35mm Medium Bolt 4 PCS	M6*50mm Long Bolt 6 PCS	M6mm Nut 10 PCS	D18 mm Washer 15 PCS
#6 	#7 	#8 	#9 	#10 
D 12mm Small Washer 4 PCS	M6mm Wrench 1 PC	M6mm Allen Key 1 PC	L Foot 2 PCS	Plastic Clip 2 PCS

EXTRA HARDWARE LIST

<p>#1</p>  <p>M6*30mm</p>	<p>#2</p>  <p>M6*35mm</p>	<p>#3</p>  <p>M6*50mm</p>	<p>#4</p>  <p>M6mm</p>	<p>#5</p>  <p>D 18mm</p>
<p>Short Bolt 1 PC</p>	<p>Medium Bolt 1 PC</p>	<p>Long Bolt 1 PC</p>	<p>Nut 1 PC</p>	<p>Washer 1 PC</p>
<p>#6</p>  <p>D 12mm</p> <p>Small Washer 1 PC</p>				

Step 1. Lay back panel (part A) down on a soft flat surface, such as carpet, as shown below. Attach seat panel (part B) to back panel (part A) using long bolts(part #3), washers (part #5), nuts (part #4), wrench(part #7) and allen key (part #8).

NOTE:Please do not fully tighten bolts until unit is fully assembled.

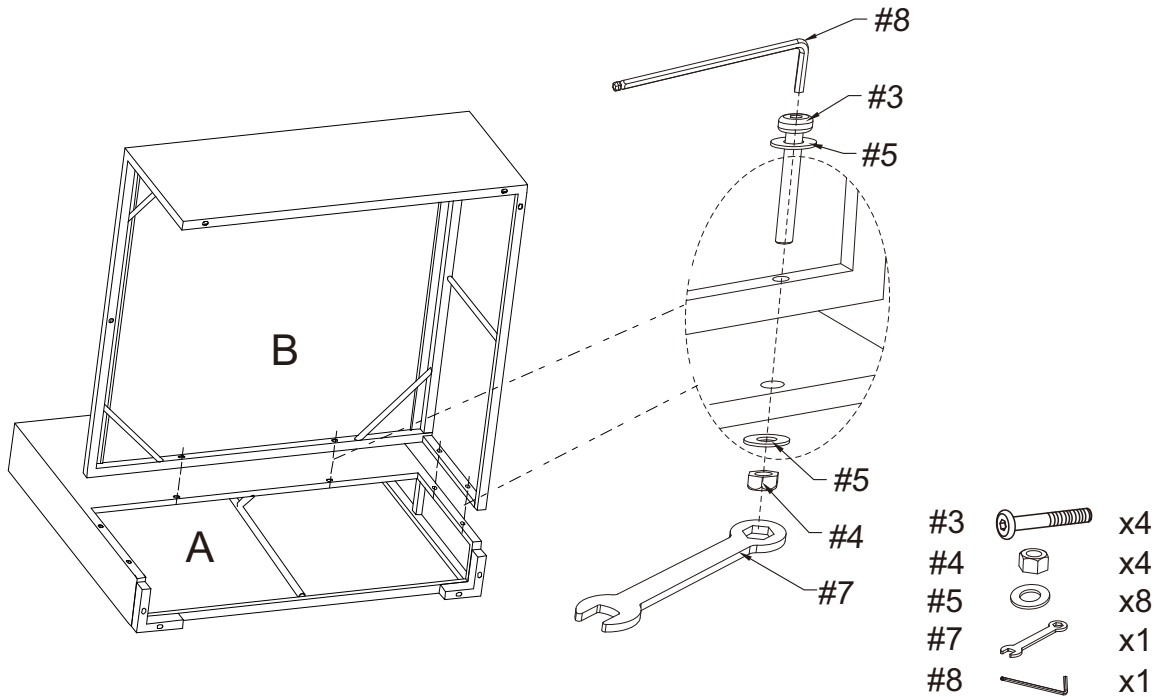

Step 2. Attach side panel (part C) to assembled unit (parts A&B) using short bolts (part #1) long bolts (part #3) , washers (part #5) , nuts (part #4),wrench (part #7) and allen key (part #8).

NOTE:Please do not fully tighten bolts until unit is fully assembled.

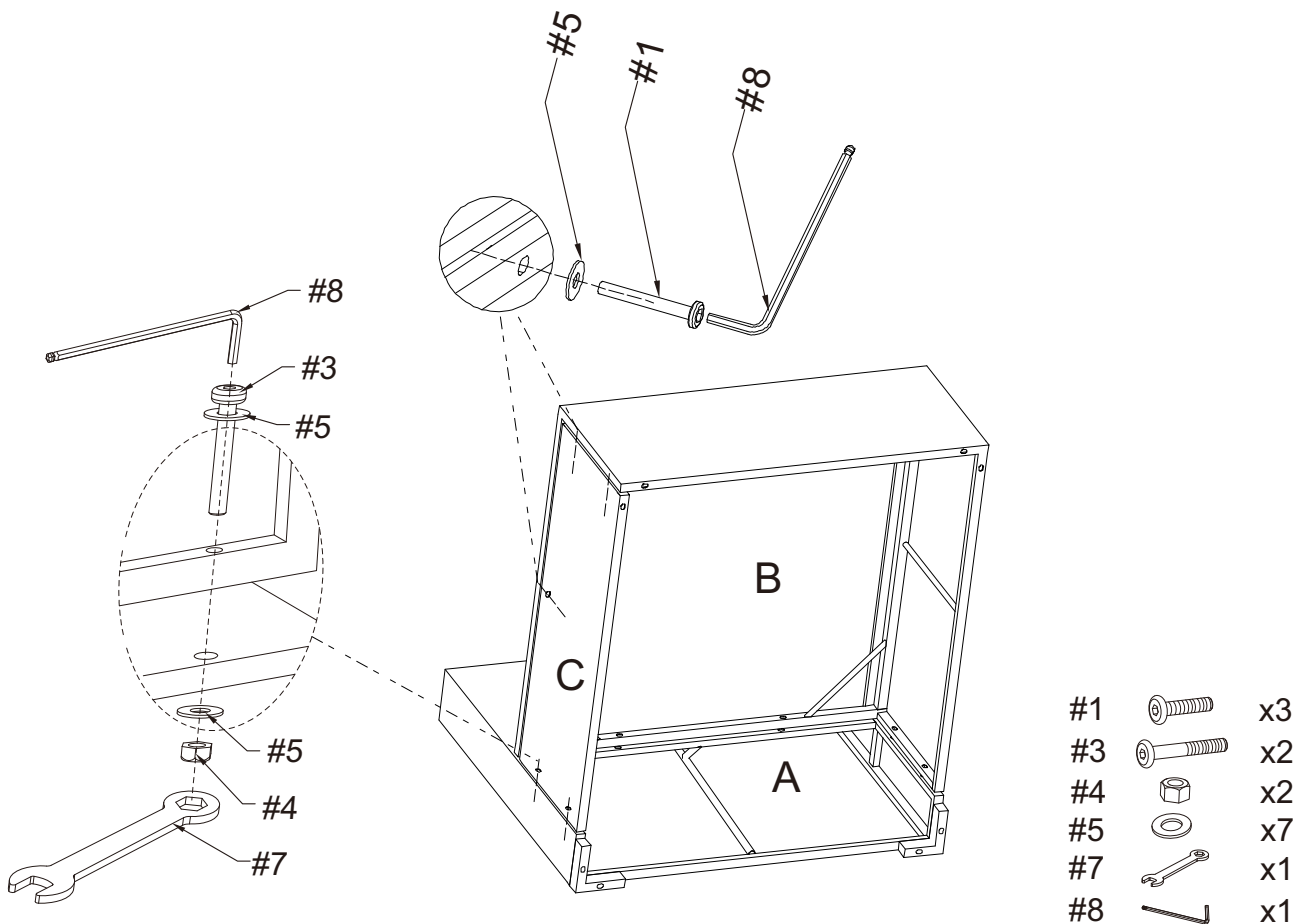

Step 3. Attach L feet (part #9) to assembled unit (parts B&C) using medium bolts (part #2), small washers (part #6), nuts (part #4), wrench (part #7) and allen key (part #8).

NOTE: Please fully tighten all bolts at this time.

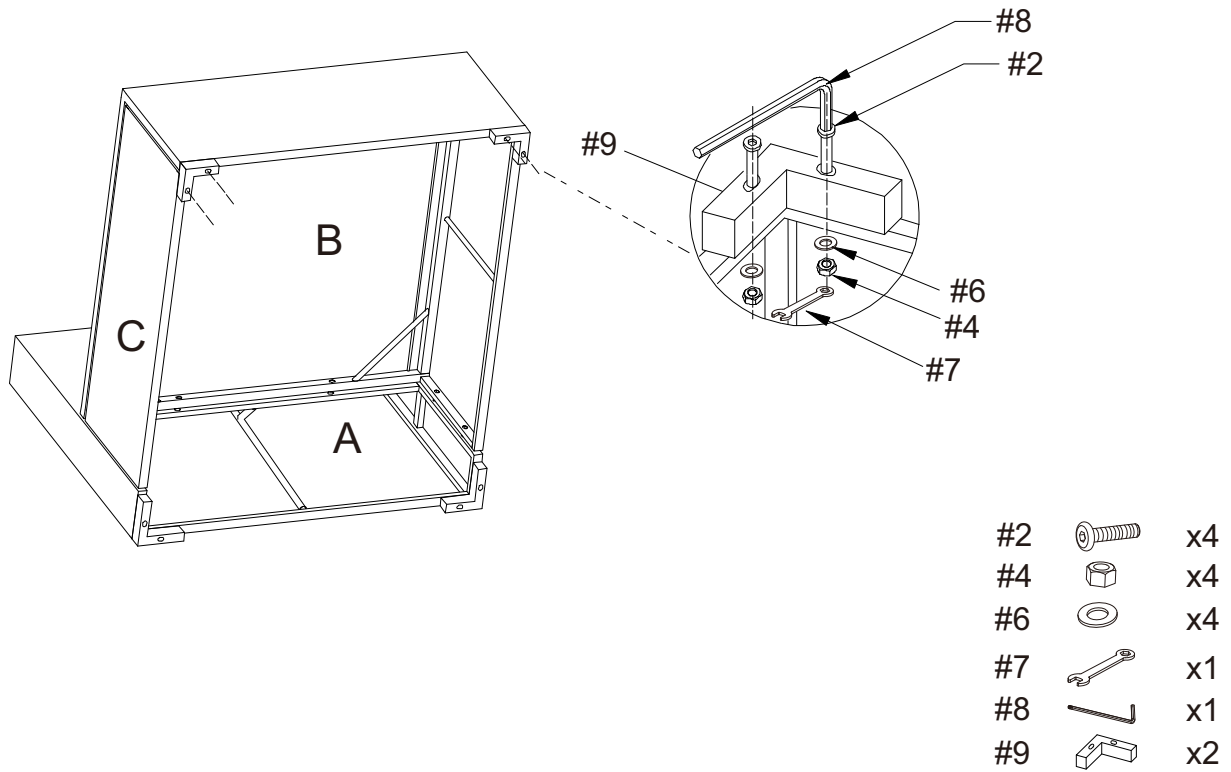

Step 4. Insert core of seat cushion (part F) into cover of seat cushion (part E).
Insert core of back cushion (part H) into cover of back cushion (part G).

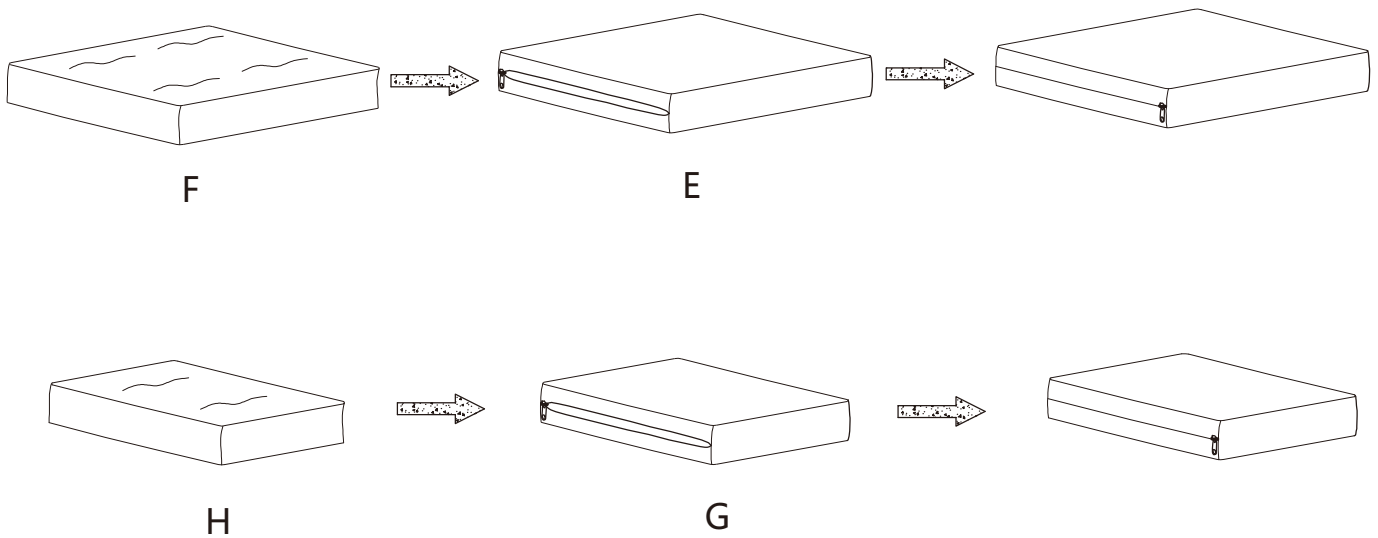

Step 5. Carefully turn the assembled chair upright and add cushions as shown below.

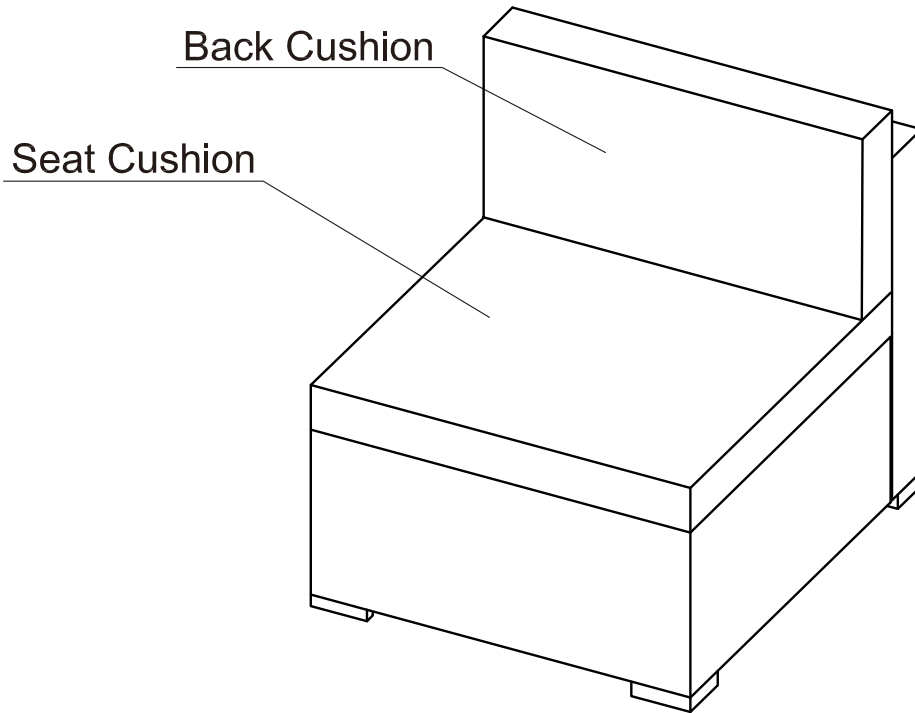

Step 6. Use plastic clips (part #10) to secure additional units together as shown.

