

Dining Table

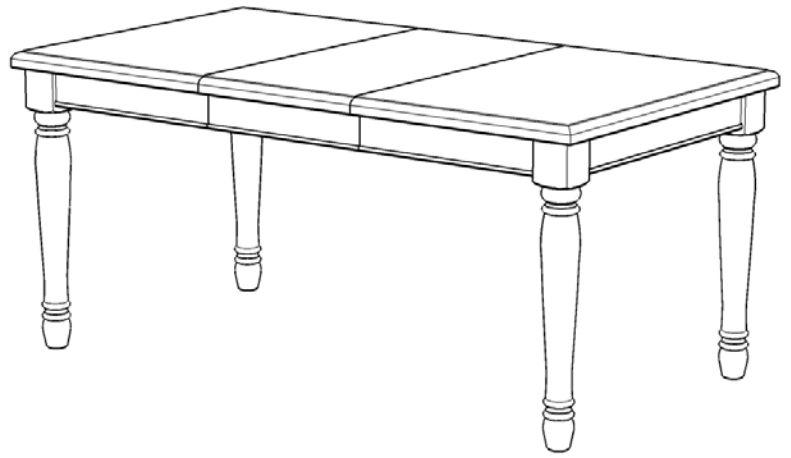

IMPORTANT NOTE

Carefully remove all the parts from the carton and put them individually on a soft cloth to prevent scratches or other damages occurring to the parts.

We have taken great care in the design of this product and request that you carefully and strictly follow our assembly instructions to ensure a completed product as it was designed.

Part List

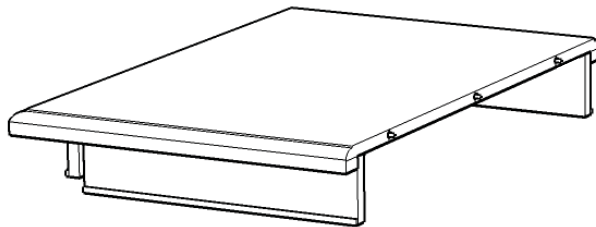

A.
Top
1 pc.

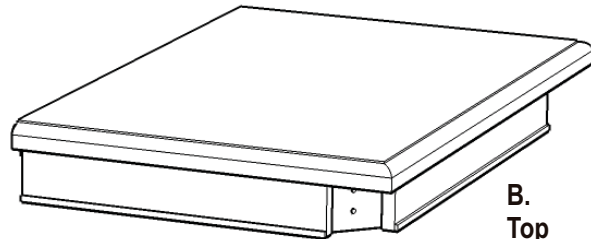

B.
Top
1 pc.

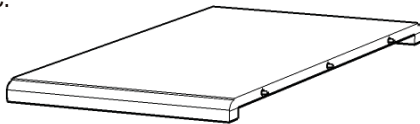

C.
Leaf
1 pc.



D.
Apron
2 pcs.



E.
Leg
4 pcs.

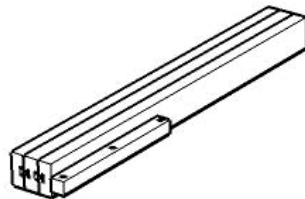

F.
Table Slide
2 pcs.

Hardware List



Hex Wrench
1 pc.



Key Wrench
1 pc.



Spring Washer
8 pcs. (+1 extra)



Spring Washer (Small)
12 pcs. (+1 extra)



**M3.5x32
Wood Screw (short)**
6 pcs. (+1 extra)



**M3.5x40
Wood Screw**
16 pcs. (+1 extra)



**Small
Hex Wrench**
1 pc.



**M8x50
Bolt**
8 pcs. (+1 extra)



Flat Washer
8 pcs. (+1 extra)



Flat Washer (Small)
12 pcs. (+1 extra)



**M6x40
Head Cap Bolt**
12 pcs. (+1 extra)

Tools required for assembly : Phillips screwdriver

Tools recommended for assembly : Level

IMPORTANT

- * Do not tighten up all the screws until each part is properly assembled.
- * You should keep Hex Wrench in a safe place as you may need to tighten up the Head Cap Bolts in the future.
- * After assembly, item must be level to work properly. Use the included adjustable levelers to level.
- * Use a soft cloth between these parts and the floor.

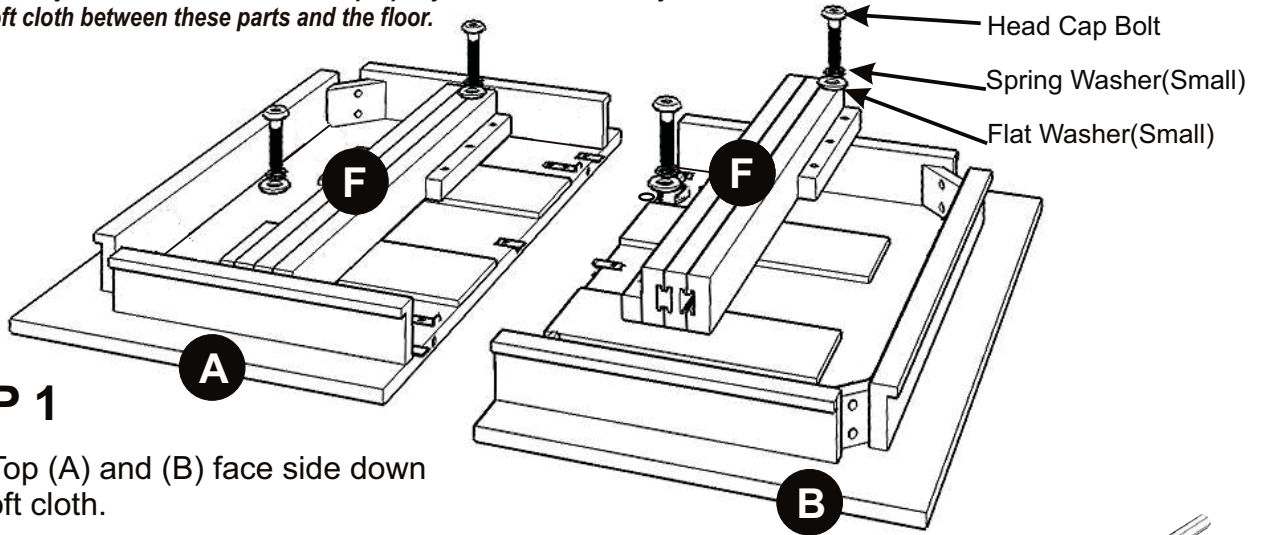

STEP 1

Place Top (A) and (B) face side down on a soft cloth.

Remove Table Slides (F) from their packing position by loosening and removing Head Cap Bolts, Spring Washers (Small) and Flat Washers (Small) using Hex Wrench. (see Figure 1)

Note: These 4 Head Cap Bolts, Spring Washers (Small) and Flat Washers (Small) will be used in Step 2.

DO NOT DISCARD

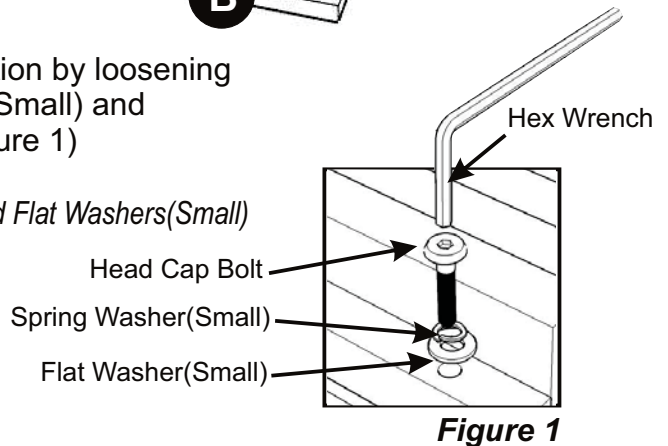

Figure 1

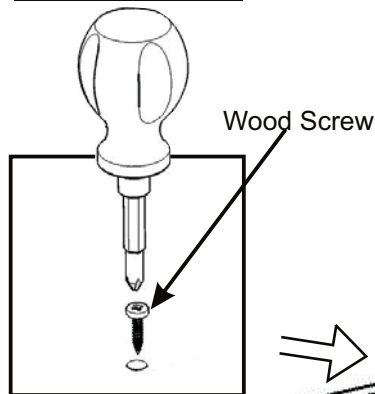
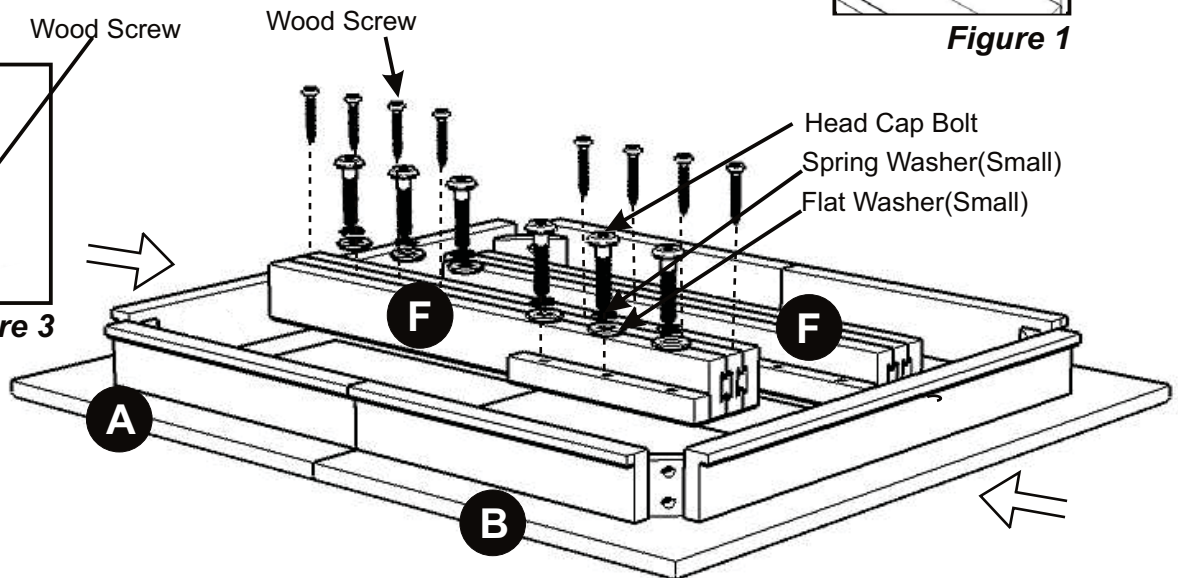

Figure 3



STEP 2

Attach Top (A) with (B), by aligning dowels with the holes and firmly pushing together.

Engage the locks by turning their handles clockwise $\frac{1}{4}$ turn (see Figure 2).

Attach Table Slides (F) to the unit using Head Cap Bolts, Spring Washers (Small) and Flat Washers (Small).

Tighten Wood Screws (see Figure 3).

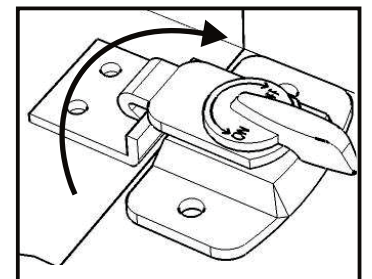
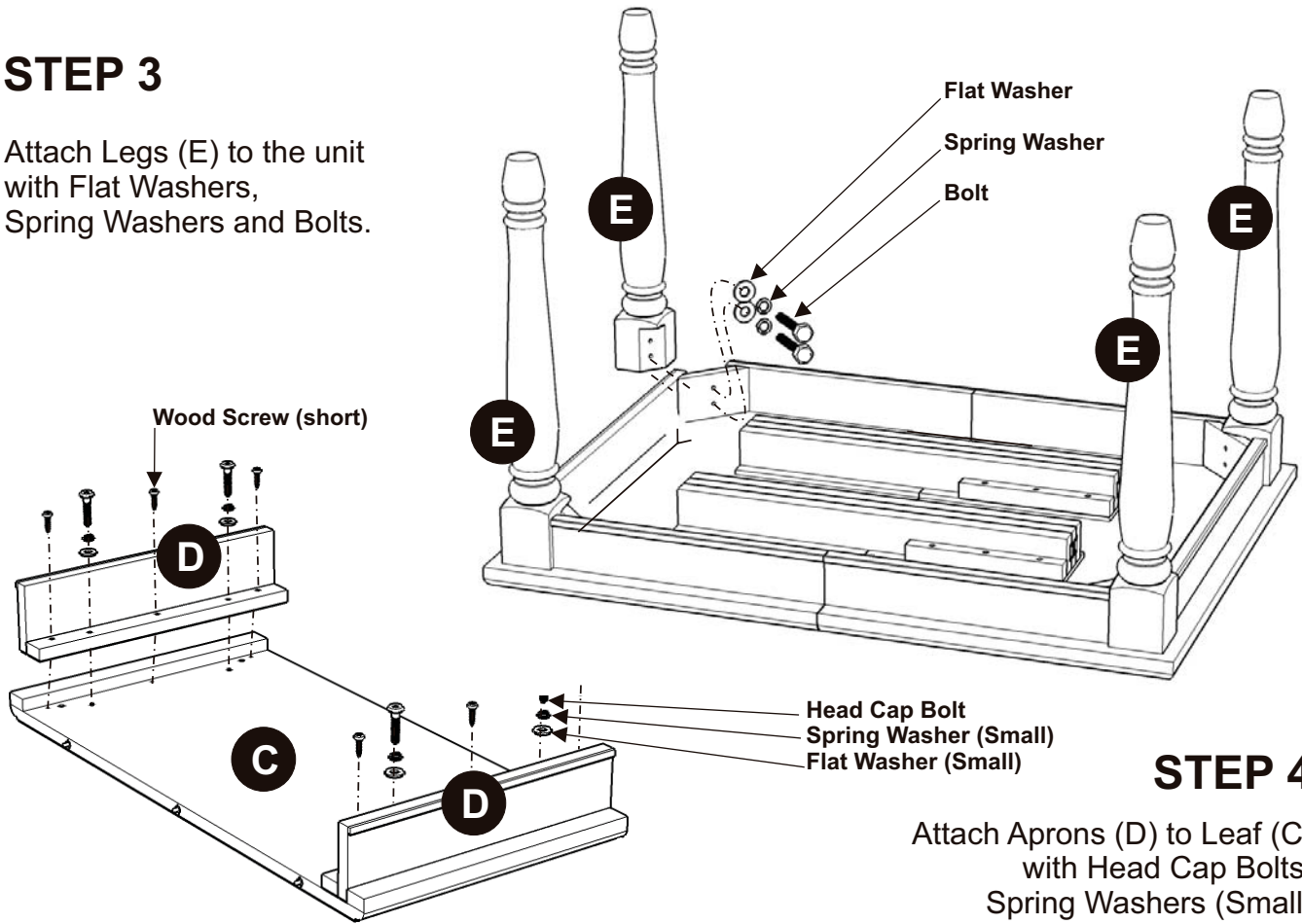

Figure 2

STEP 3

Attach Legs (E) to the unit with Flat Washers, Spring Washers and Bolts.



STEP 4

Attach Aprons (D) to Leaf (C) with Head Cap Bolts, Spring Washers (Small), Flat Washers (Small) and Wood Screws (short).

Adding the Leaf

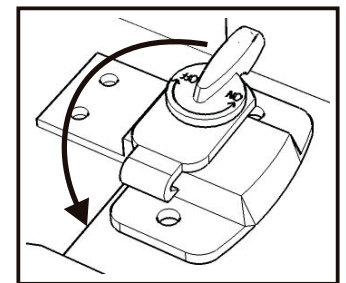
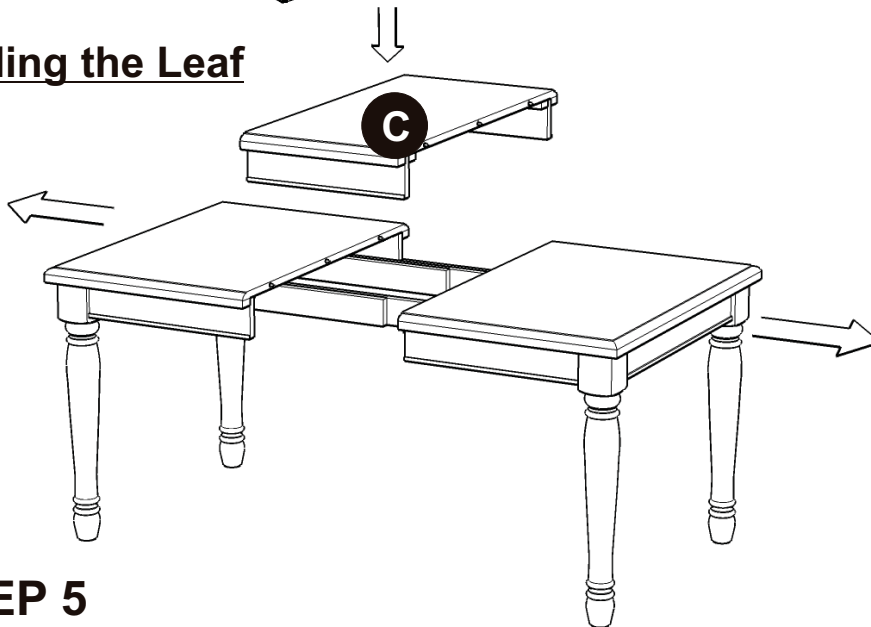

(Figure 3)

STEP 5

Disengage the locks by turning their handles counter-clockwise $\frac{1}{4}$ turn (see Figure 3).

Pull out both sides of the table, then place Leaf (C) in the unit as shown, aligning the dowels with the holes.

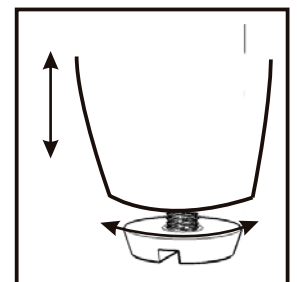

(Figure 4)

Push the table together firmly, then engage the locks by turning their handles clockwise $\frac{1}{4}$ turn (see Figure 2).

To level the unit, adjust the adjustable levelers on the bottom of unit.

(see Figure 4)

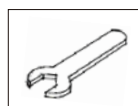

Please keep the Key Wrench as you may need to re-tighten the Bolts in the future.