

INSTRUCTIONS ASSEMBLY

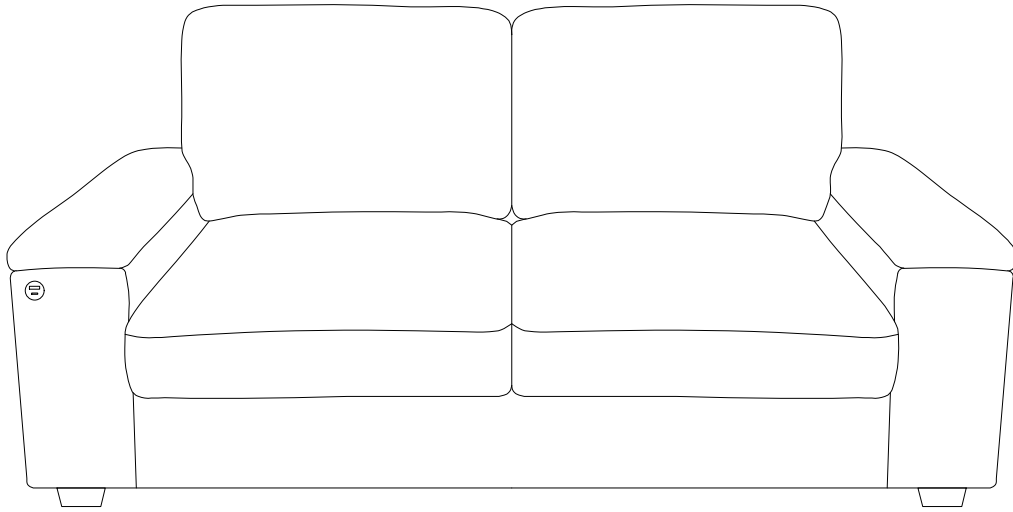

PARTS LIST

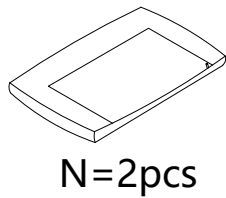
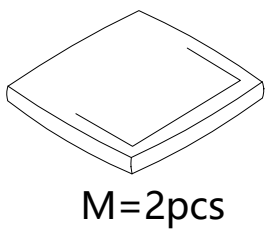
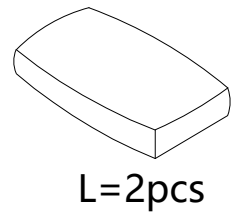
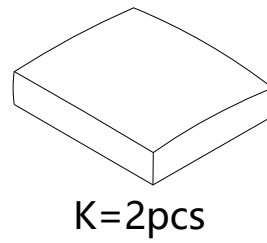
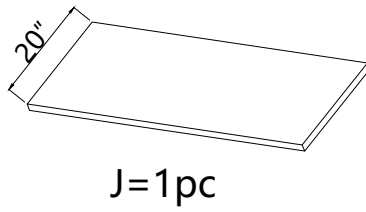
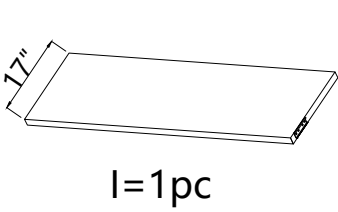
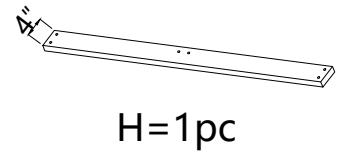
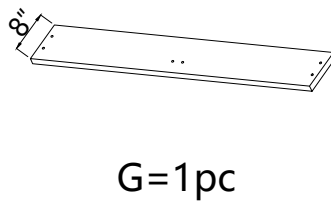
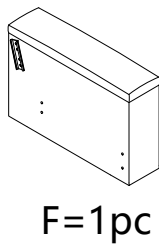
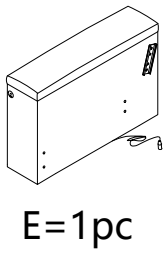
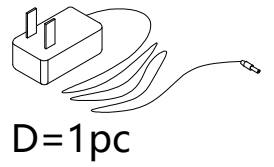
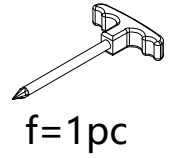
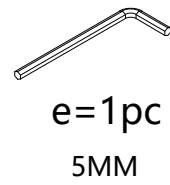
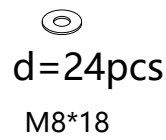
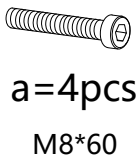

step1

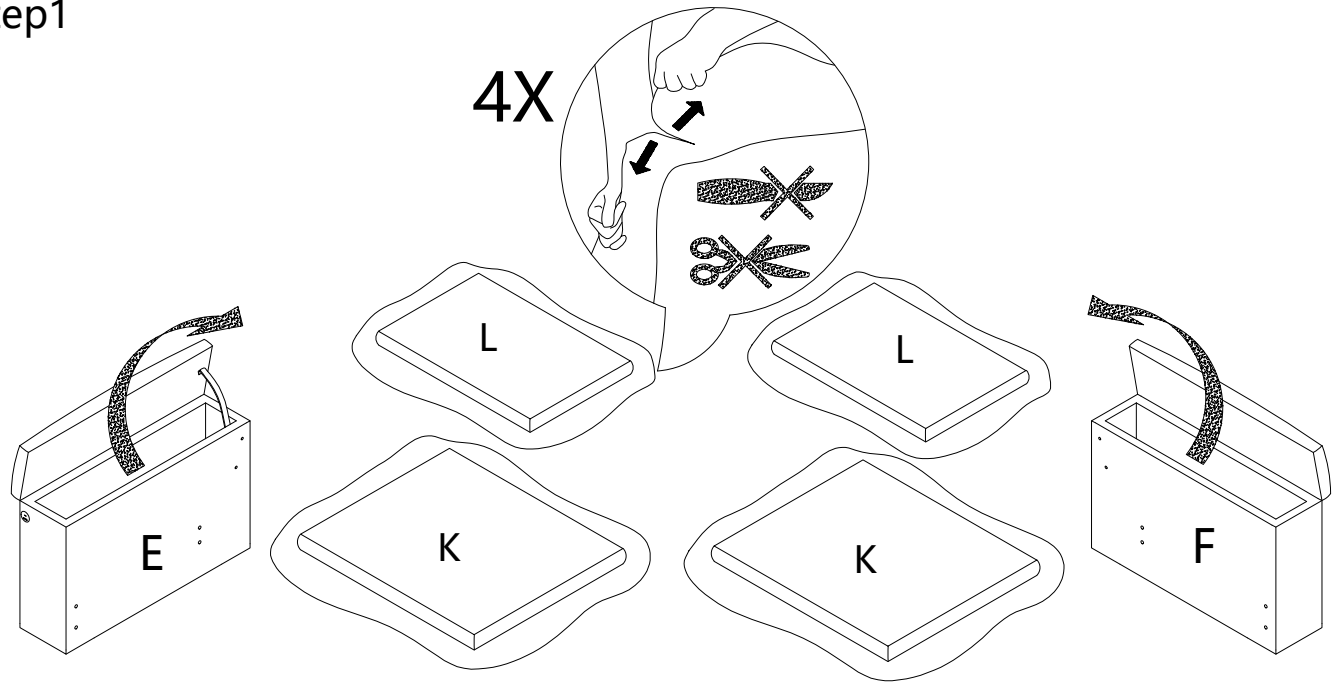

step2

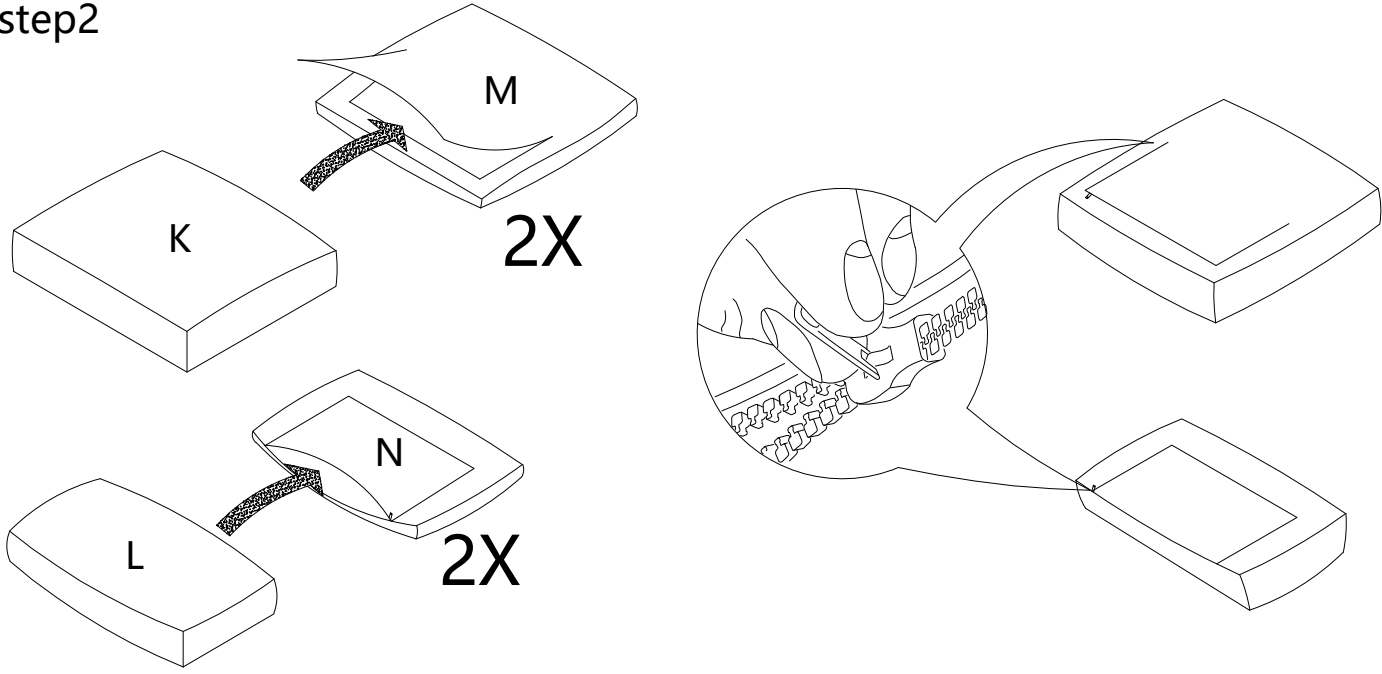

step3

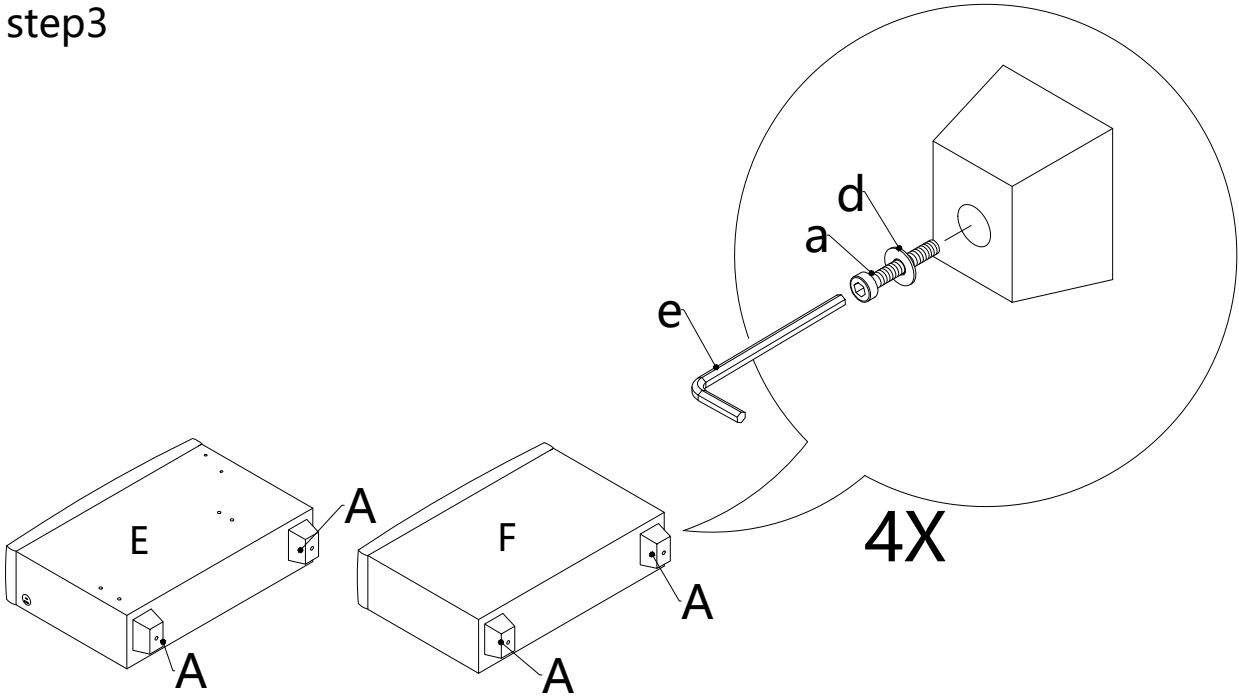

step4

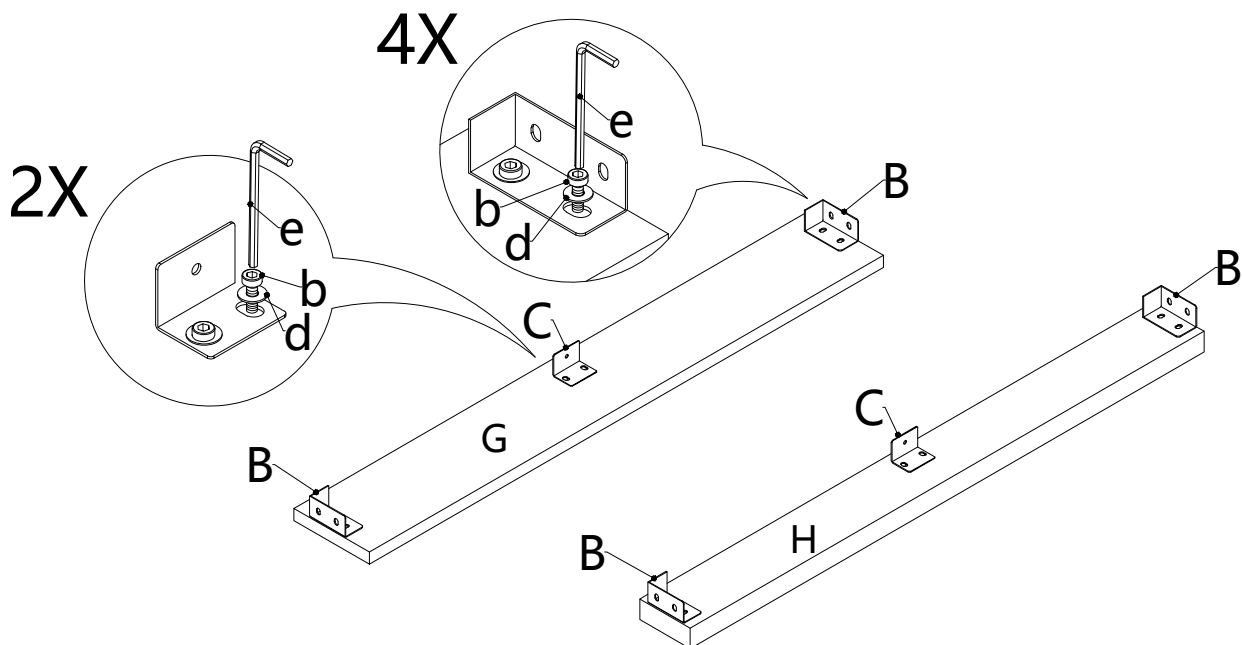

step5

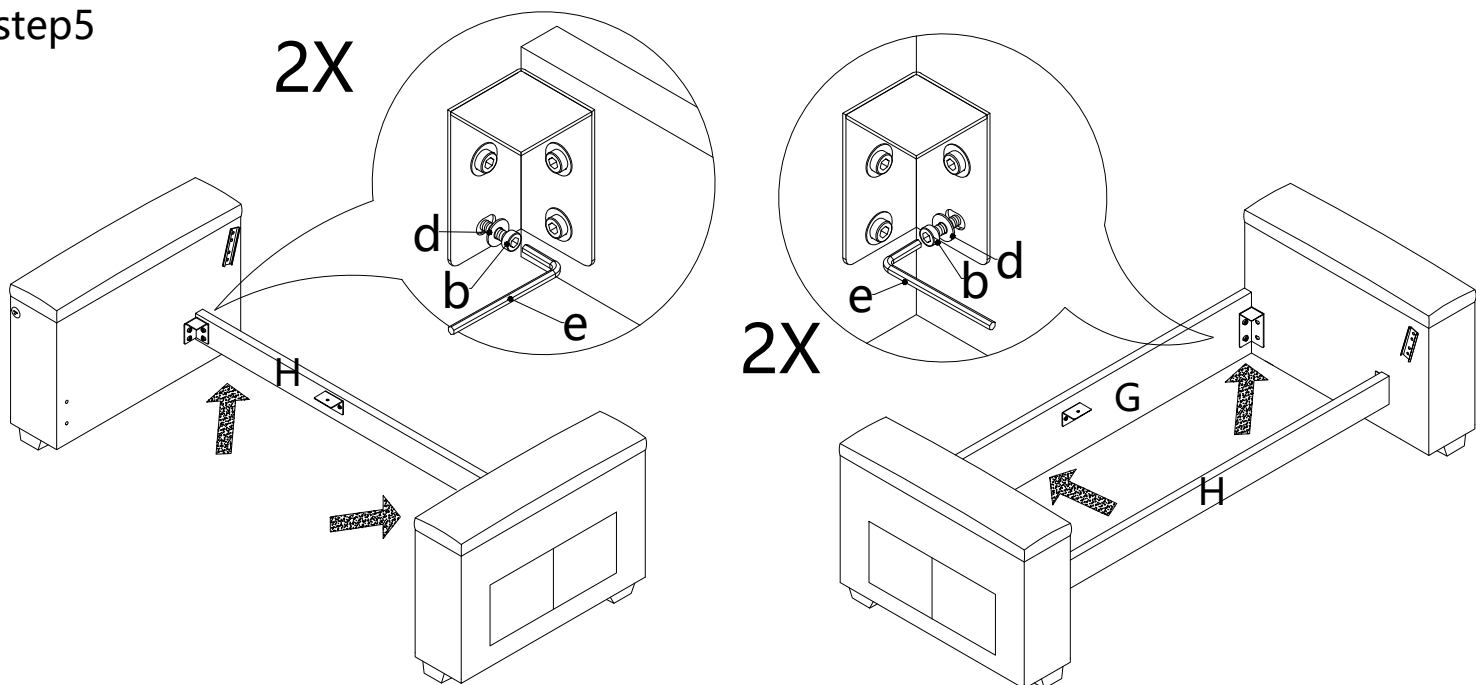

step6

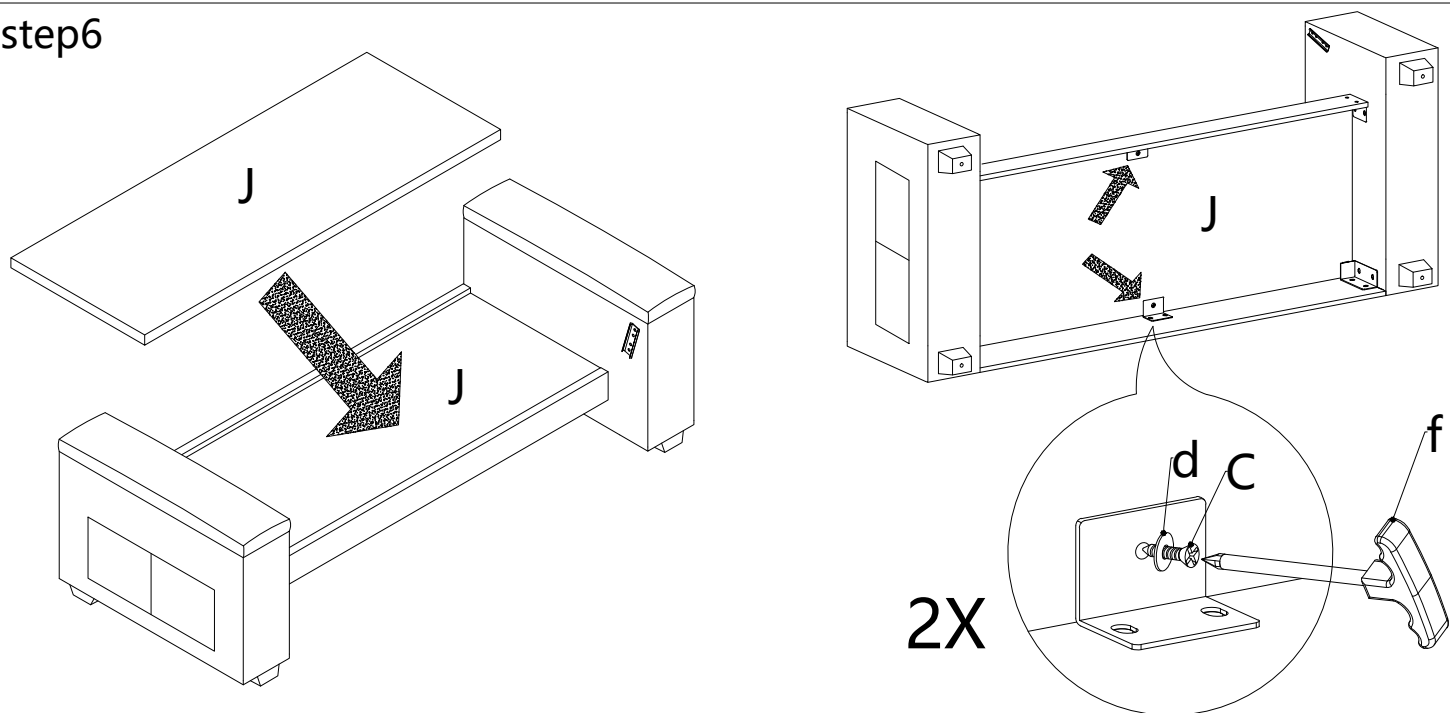

step7

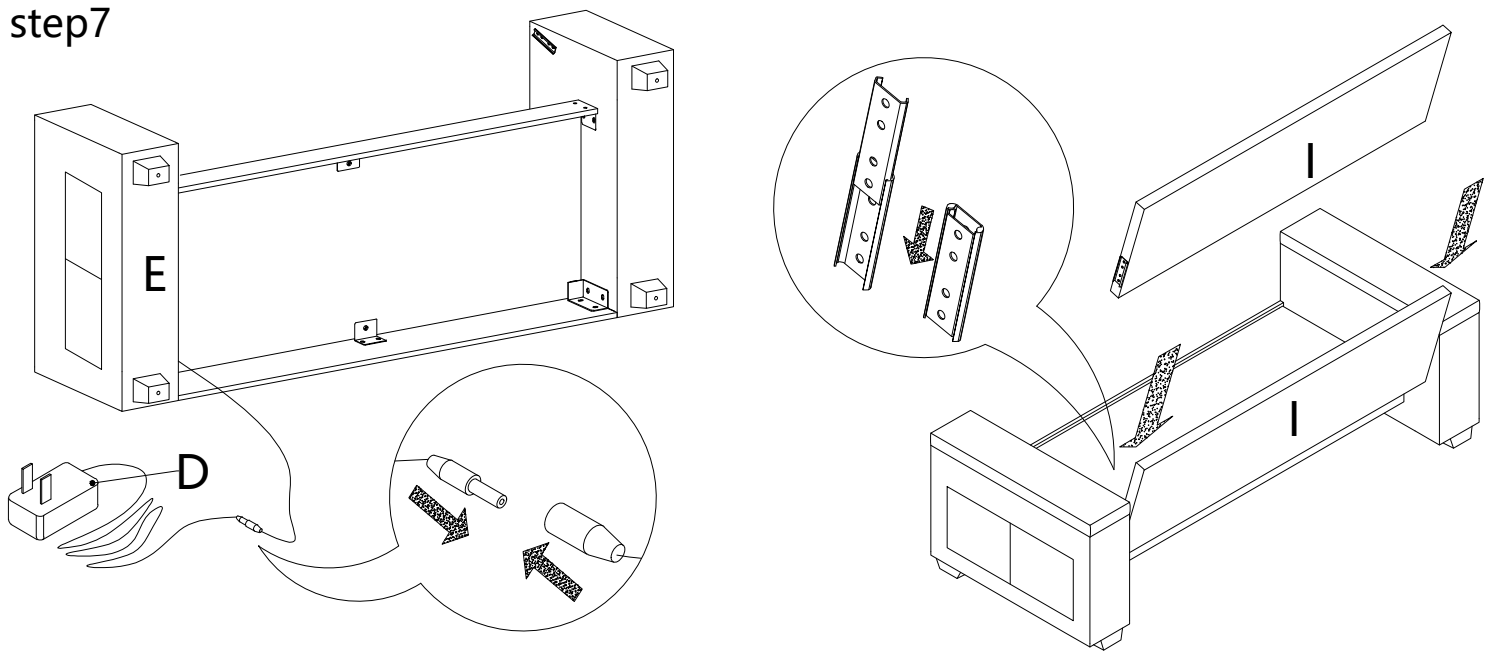

step8

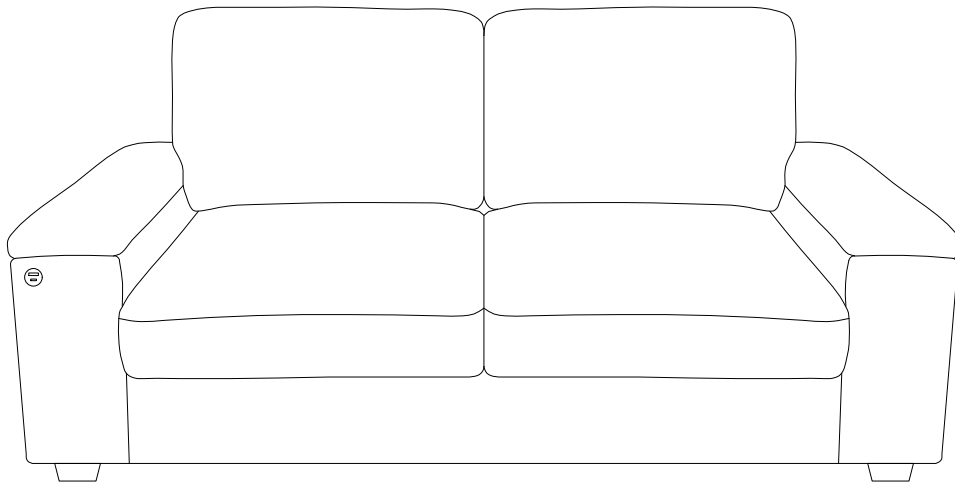
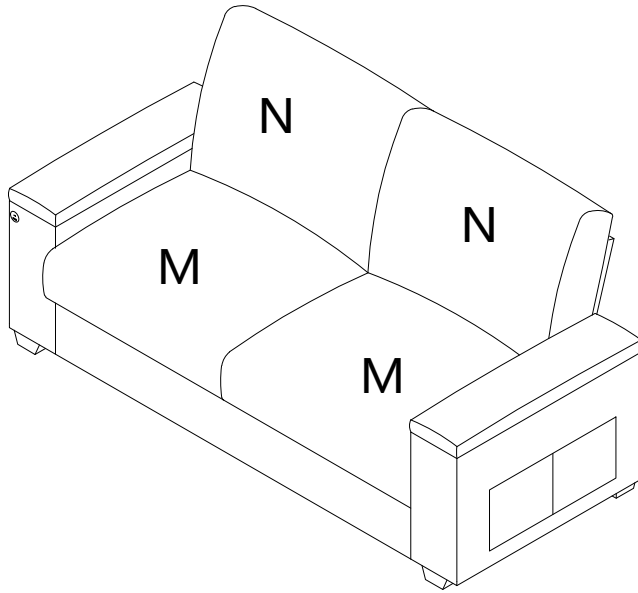

WARM TIP

1. Compressed back cushion and seat cushion should be recovered 72 hours after opening.
2. Avoid scratching, please open compressed cushion by hand, do not use scissor and knife.