

# ASSEMBLY INSTRUCTIONS





Item No : D1651-15B OSCAR DINING TABLE FOR GLASS TOP TABLE











D1651-15T OSCAR ROUND GLASS TOP FOR STD OR COUNTER DINING BASE

Thank you for purchasing this quality product. Be sure to check all packing materials carefully for small parts, which may have come loose inside the carton during shipment. Identify and count all items and compare with the parts list and/or hardware list shown below.

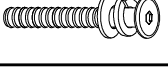
**IMPORTANT NOTE :**

- \* PLACE ALL WOODEN PARTS ON A CLEAN AND SMOOTH SURFACE SUCH AS A RUG OR CARPET TO AVOID THE PARTS FROM BEING SCRATCHED.
- \* PLEASE DO NOT OVERTIGHTEN THE SCREWS TO AVOID CRACKING THE PARTS.
- \* BEFORE YOU BEGIN, KINDLY REVIEW THE ASSEMBLY INSTRUCTIONS AND FOLLOW STEP BY STEP.
- \* KEEP ALL HARDWARE PARTS OUT OF REACH OF CHILDREN.

PARTS LIST			
NO	DESCRIPTION	SKETCH	QTY
A	Glass Top		1 Pc
B	Leg		4 Pcs
C	Shelf		1 Pc
D	Mounting Box		1 Pc

HARDWARE LIST			
NO	DESCRIPTION	SKETCH	QTY
1	Hex Nut 5/16"		8 Pcs
2	Spring Washer 5/16"		8 Pcs
3	Flat Washer 5/16"		8 Pcs
4	Wrench		1 Pc
5	JCBC Bolt M6 x 2 6/8" w/ Spring Washer M6 and Flat Washer M6 x 4/8"		4 Pcs
6	Allen Key M4		1 Pc
7	JCBC Bolt M6 x 1"		4 Pcs
8	Allen Key M3		1 Pc
9	Threaded Rod		8 Pcs
10	Aluminium Die		4 Pcs

**STEP 1 :** Remove the plastic bolt cover on each table leg (B) before assembling the table. Attach the table leg (B) to the mounting box (D) by insert the bolts on the legs into the respective holes on the box and assemble the table legs (B) to the mounting box (D) by using the Wrench (4) with hardware 1, 2, and 3.

**\*DO NOT TIGHTEN THE NUTS.**

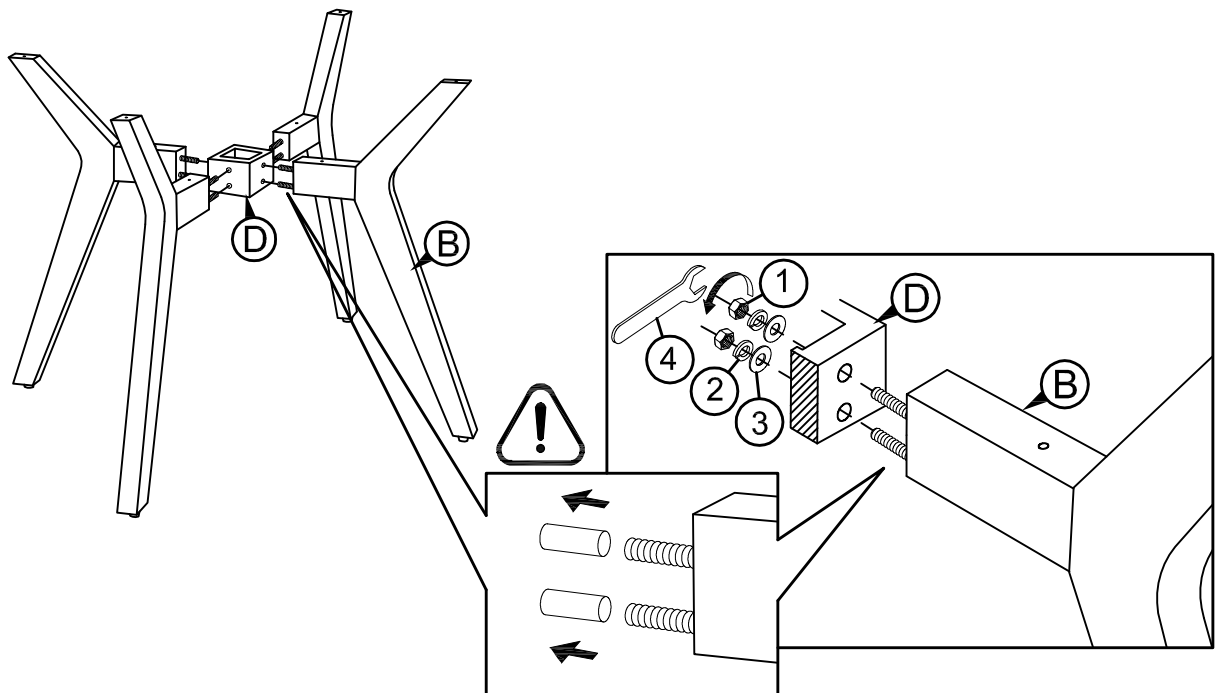

STEP 2 : Face the larger hole of the Aluminium die (10) upward and align the hole on the die to the screw hole on the top of leg (B). Assemble the Aluminium die (10) with the leg (B) by using the Allen Key (6) with hardware 7.  
\*PLEASE FULLY TIGHTEN THE BOLT.

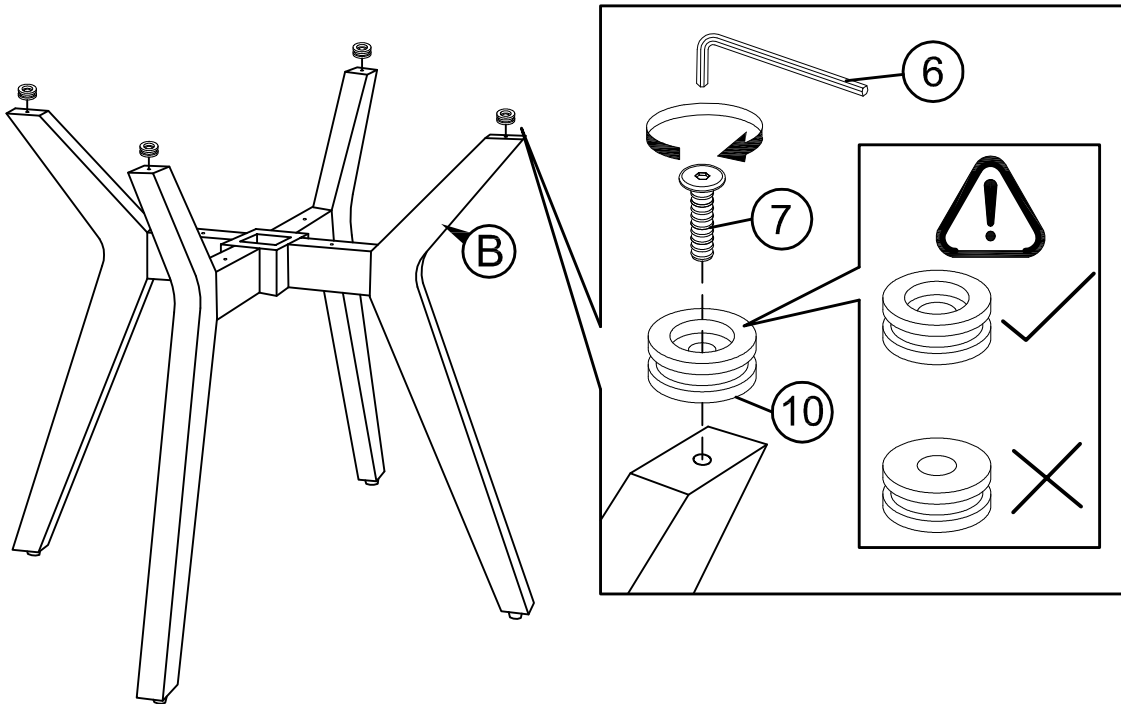

STEP 3 : Place the glass top (A) on the table base by aligning the Aluminium die (10) on the table base with the pre-installed die cap on the glass top (A).

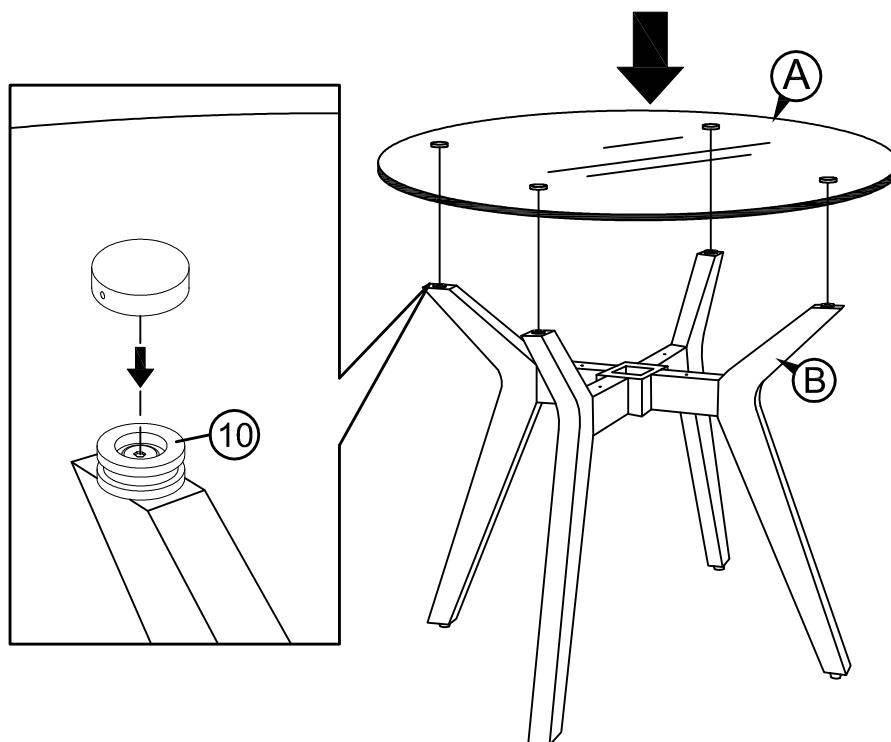

STEP 4 : Fully tighten all the Hex nuts of the table leg (B) with the mounting box (D) by using the Wrench (4).

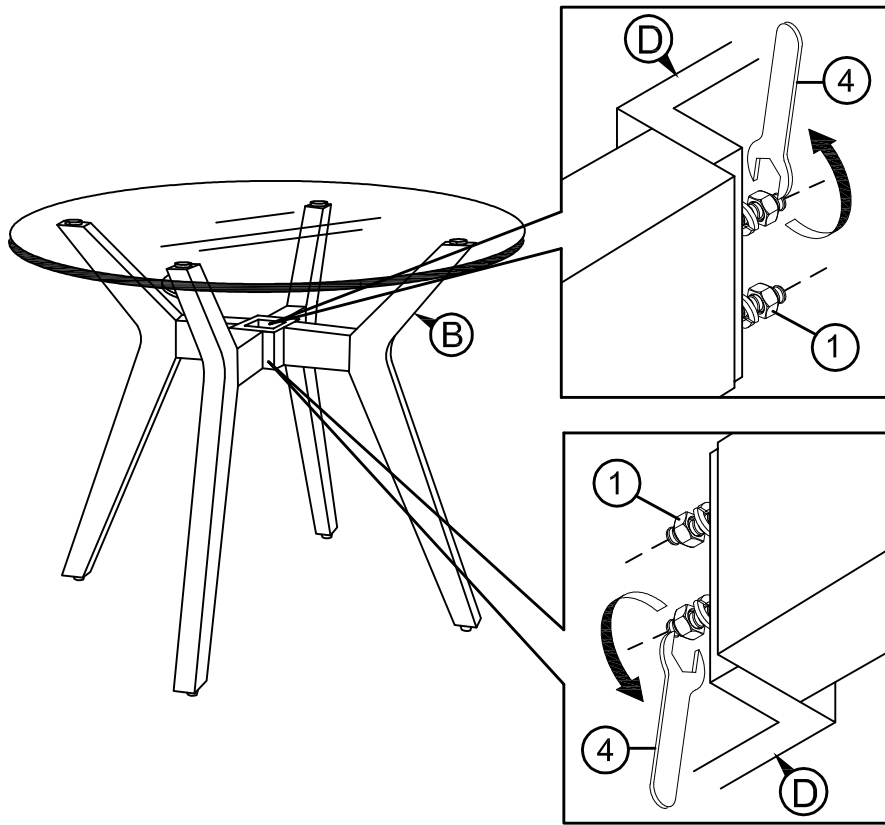

STEP 5 : Place the Shelf (C) on top of the mounting box (D) and assemble the Shelf (C) with the table leg (B) by using the Allen Key (6) with hardware 5.

**\*TIGHTEN THE BOLTS.**

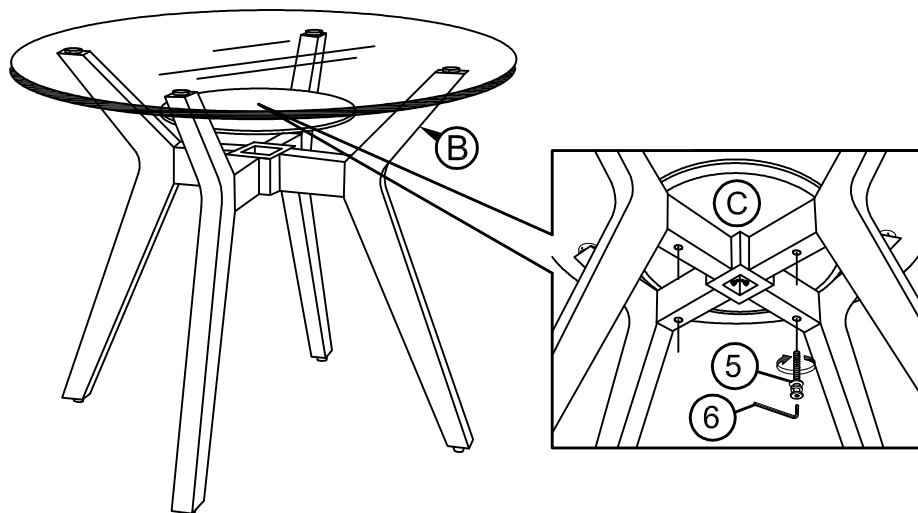

**STEP 6 :** Assemble the glass top (A) with the table base by using the Allen Key (8) with hardware 9.  
\*Attention: Make sure the hex hole on the threaded rod is facing outward to enable the Allen key to turn the rod.

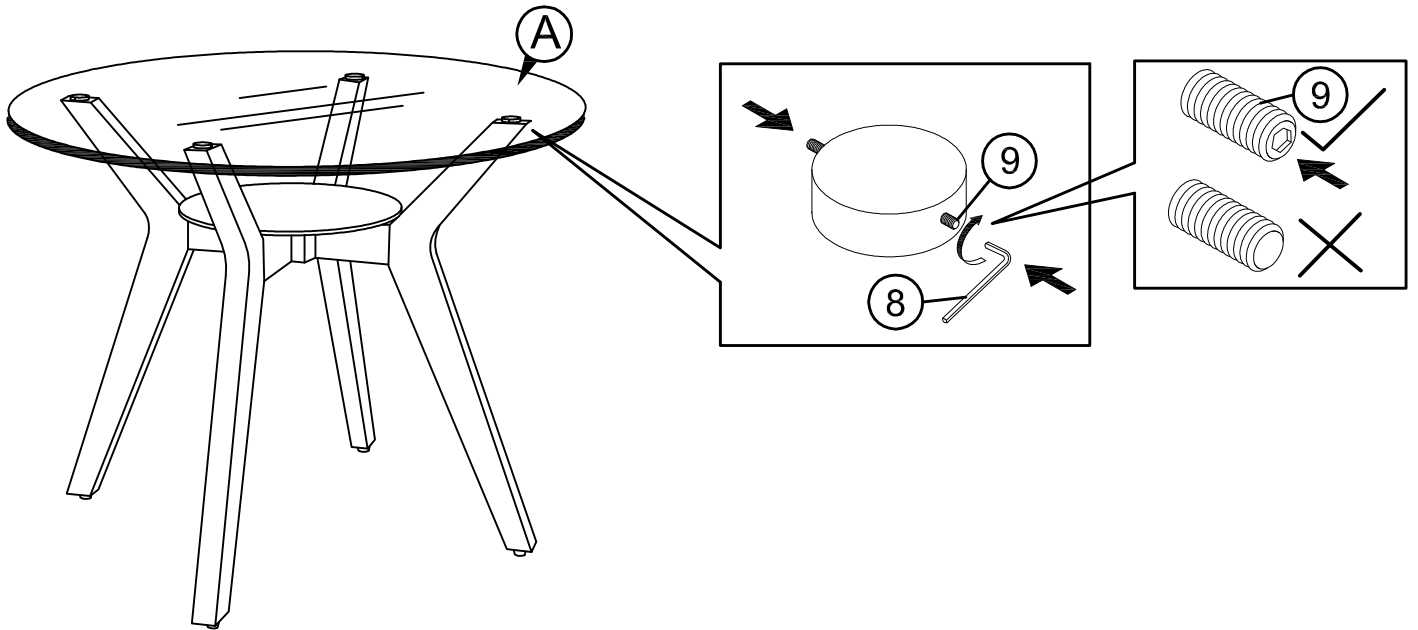

**STEP 7 :** To level the table, place the table on a flat surface and adjust the levelers on the bottom of each leg (B).

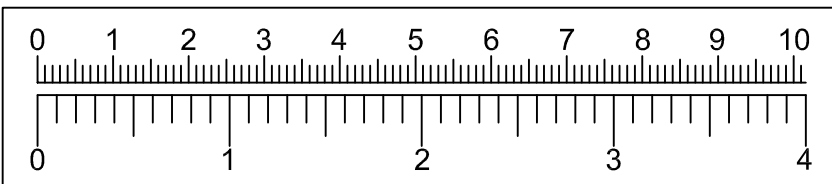
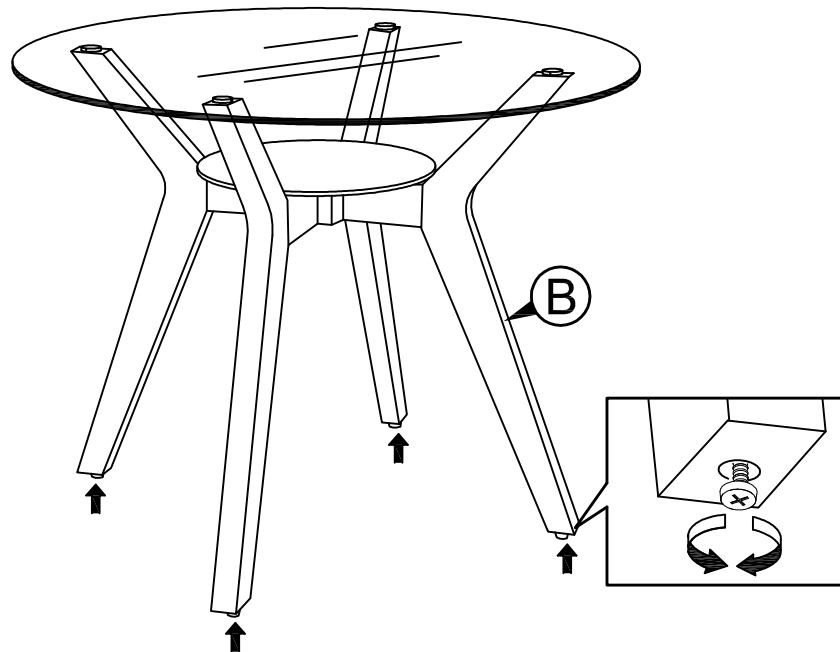



New  
Classic®  
FURNITURE

# ASSEMBLY INSTRUCTIONS

Item No : D1651-20  
Oscar Wood Back Chair  
(2PCS PER CARTON)

Thank you for purchasing this quality product. Be sure to check all packing materials carefully for small parts, which may have come loose inside the carton during shipment. Identify and count all items and compare with the parts list and/or hardware list shown below.

PARTS LIST			
NO	DESCRIPTION	SKETCH	QTY
A	Front Stretcher		2 Pcs
B	Back Stretcher		2 Pcs
C	Left Side Facing (LSF) Frame		2 Pcs
D	Right Side Facing (RSF) Frame		2 Pcs
E	Chair Back		2 Pcs
F	Cushion Seat		2 Pcs

HARDWARE LIST			
NO	DESCRIPTION	SKETCH	QTY
1	JCBC Bolt M6 x 1" w/ Spring Washer M6 and Flat Washer M6 x 4/8"		8 Pcs
2	JCBC Bolt M6 x 1 6/8" w/ Spring Washer M6 and Flat Washer M6 x 4/8"		8 Pcs
3	Allen Key M4		1 Pc
4	L Bracket		8 Pcs
5	PH CB Screw M4 x 4/8"		16 Pcs
6	Wood Dowel M8 x 1"		4 Pcs
7	Wood Button 9/16"		8 Pcs

### CAUTIONS :

(1) **DO NOT FULLY-TIGHTEN THE NUT OR NUT BOLTS INITIALLY UNTIL ALL NUTS OR BOLT IS READY ASSEMBLED.**

(TO AVOID CAUSING DAMAGES TO THE THREAD, DO NOT OVER-TIGHTEN THE NUTS OR BOLTS.)

(2) **KEEP ALL HARDWARE PART OUT OF REACH OF CHILDREN.**

**STEP 1 :** Install Front Stretcher (A) and Back Stretcher (B) to the LSF Frame (C) and RSF Frame (D) by a align the wood dowels on the stretchers into the frames.

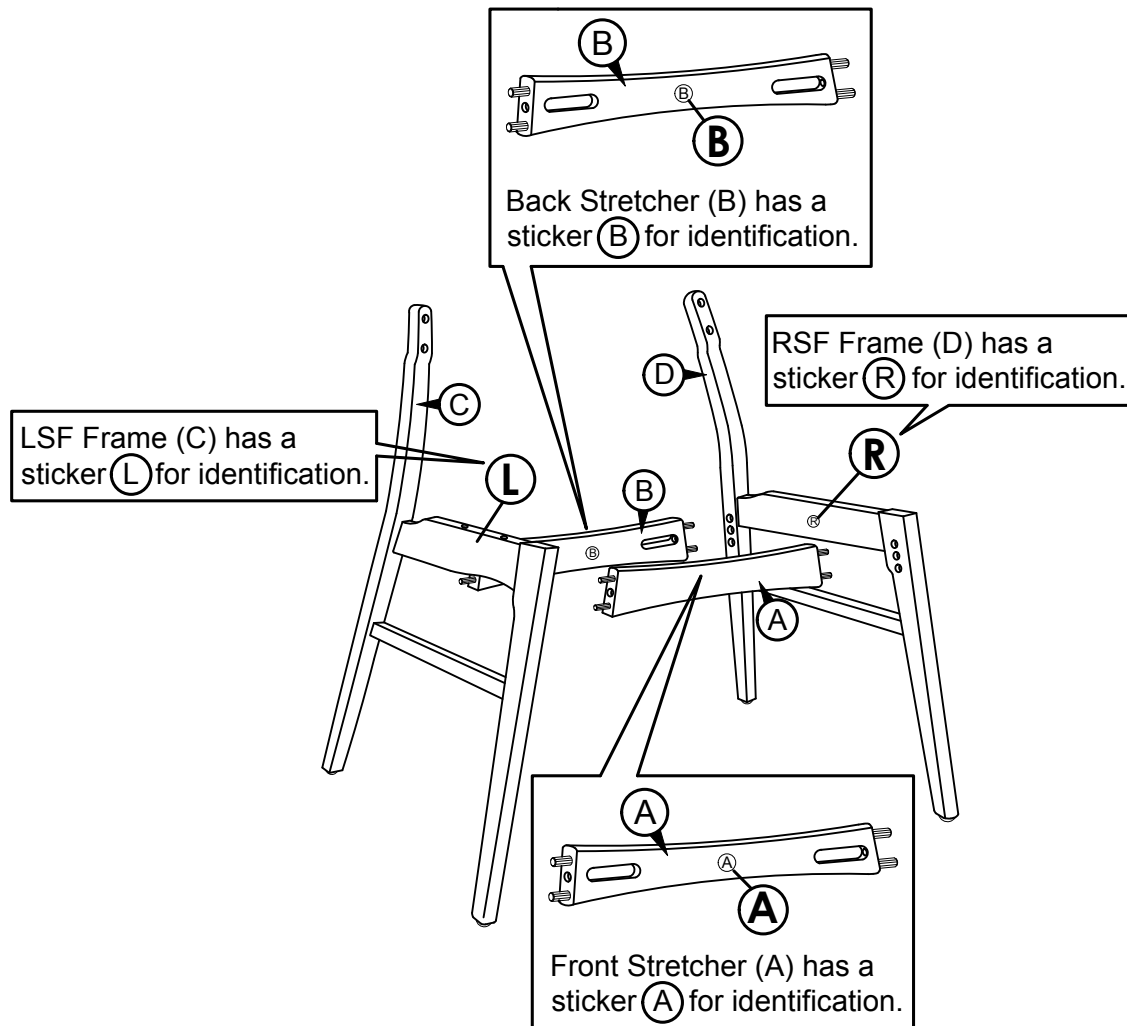

STEP 2 : Assemble the front stretcher (A) and the back stretcher (B) to the LSF Frame (C) and RSF Frame (D) by using the Allen key (3) with the hardware 2.

**\*DO NOT TIGHTEN THE BOLTS**

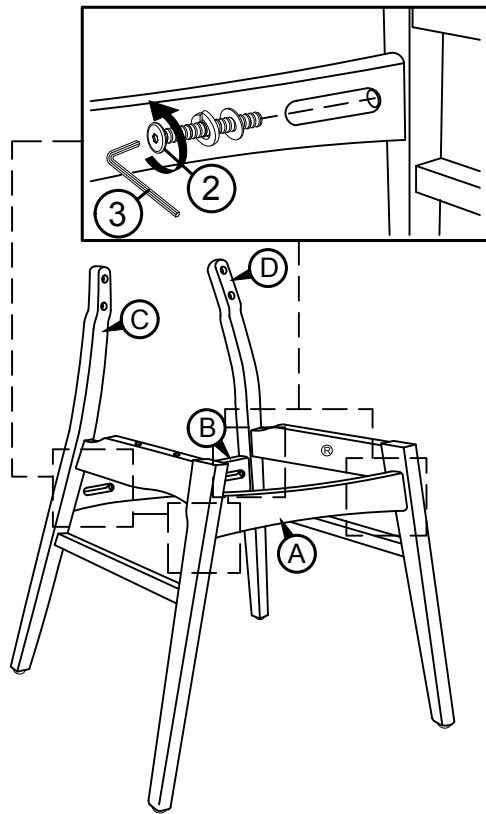

STEP 3 : Assemble the Chair back (E) to the top of the assembled chair frame by using the Allen Key (3) with the hardware 1.

**\*DO NOT TIGHEN ALL THE BOLTS OF THE CHAIR BACK (E) UNTIL ALL BOLTS ARE IN PLACE and be careful not to over-tighten.**

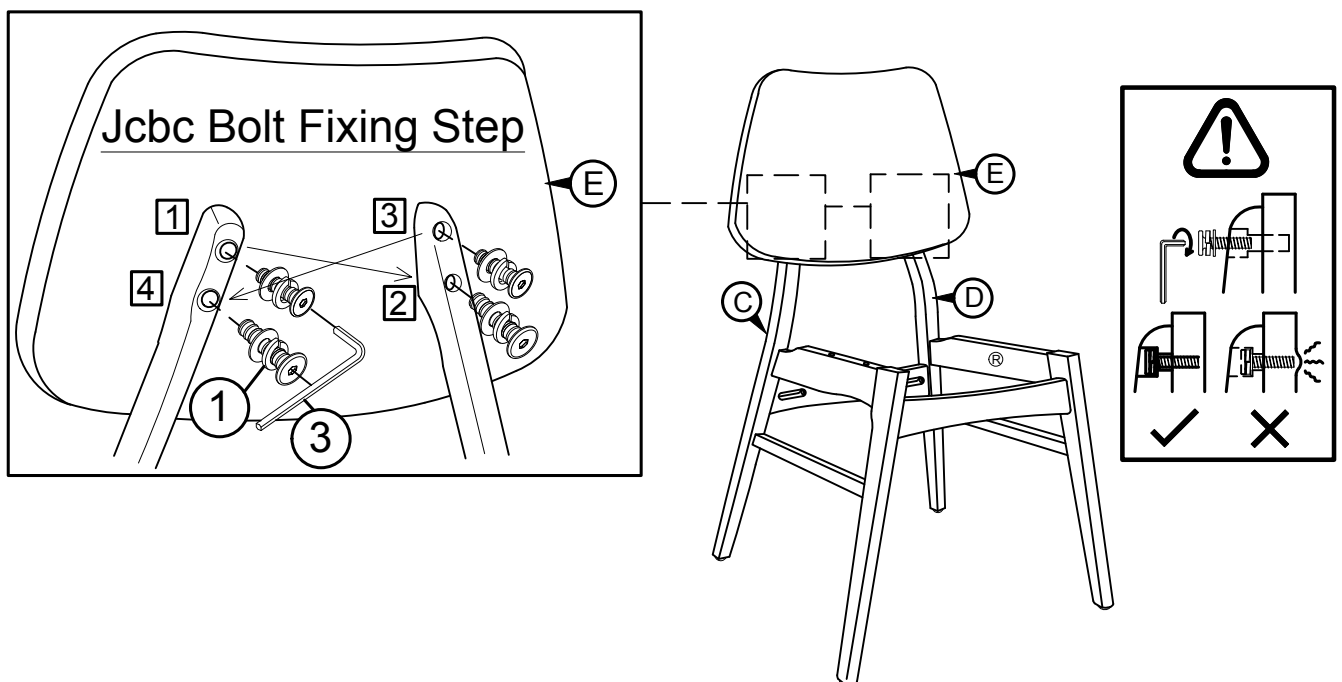

STEP 4 : Install the wood button on the chair back (E) by use a wood mallet to lightly tap in each wood button (7) to conceal the screw holes.

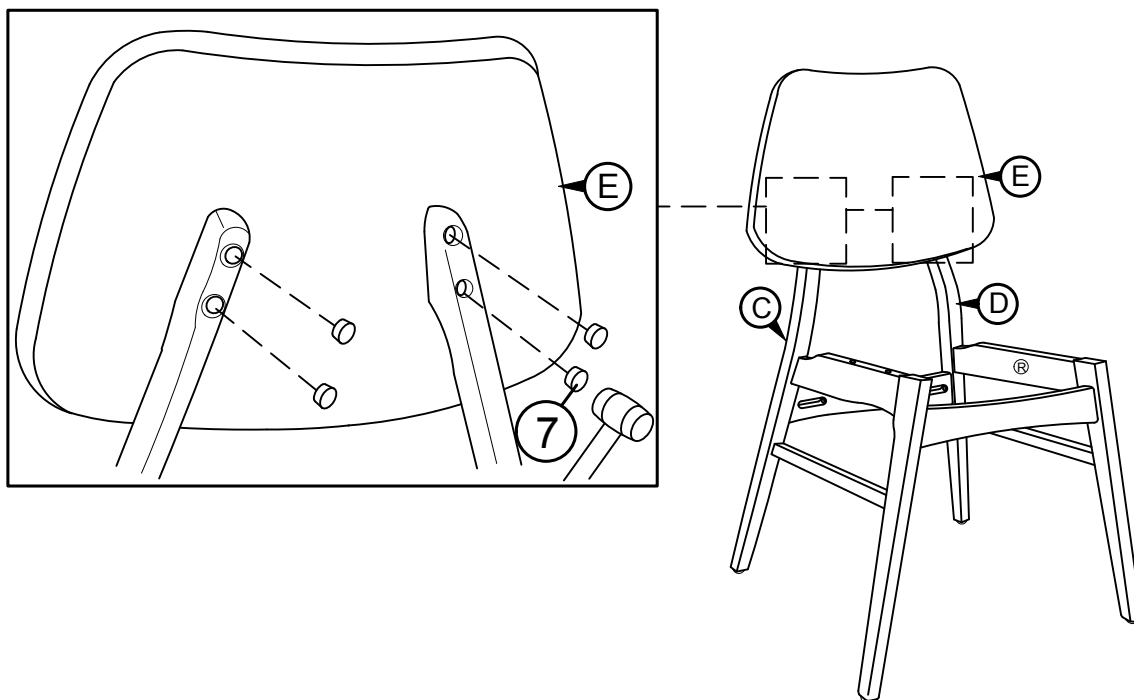

STEP 5 : To level the chair, place the chair on a flat surface and tighten all the bolts using Allen Key (3).

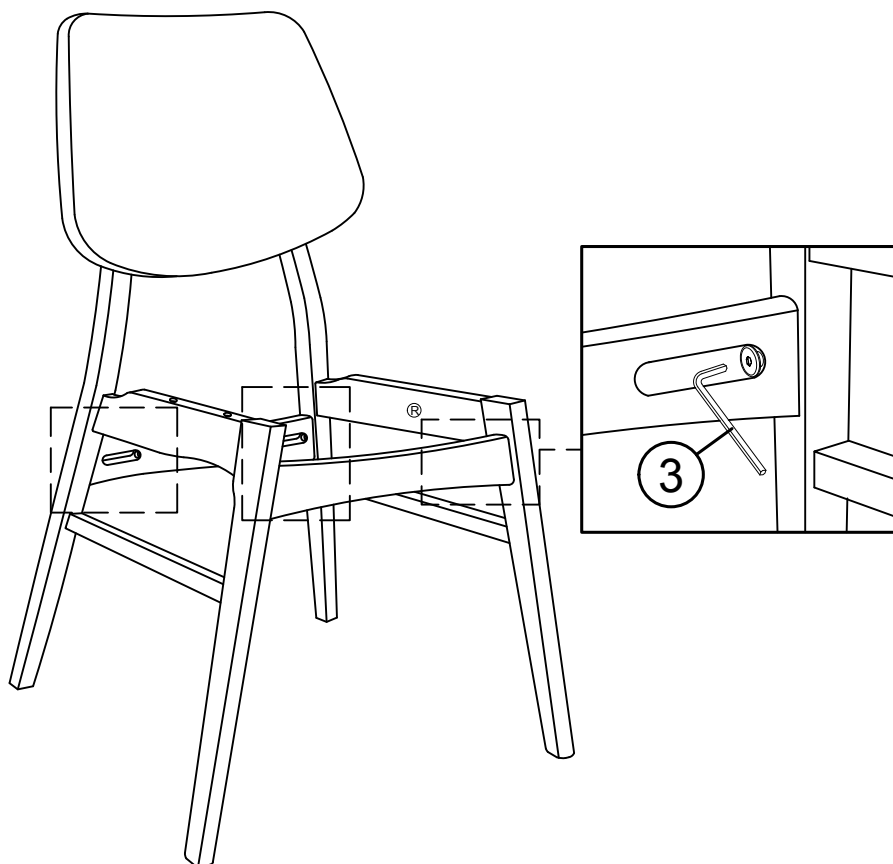

STEP 6 : Insert Wood Dowel (6) into the designated hole on LSF Frame (C) as shown.

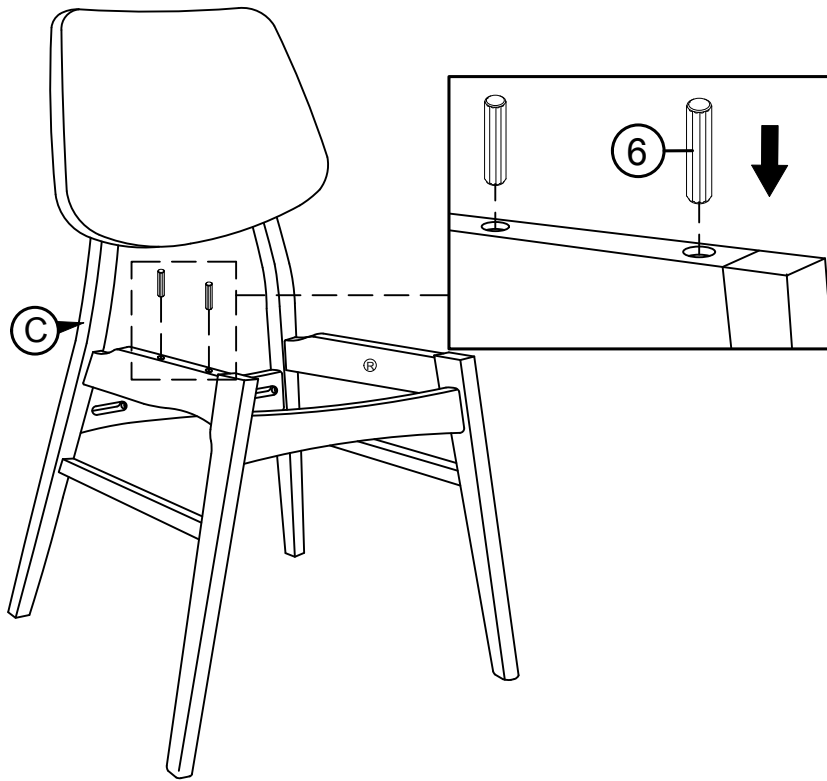

STEP 7 : Place the Cushion Seat (F) bottom-side up on a elevated surface (e.g. table top). Then place the chair frame upside down so the wood dowels on the LSF frame (C) are positioned into the Cushion Seat (F).

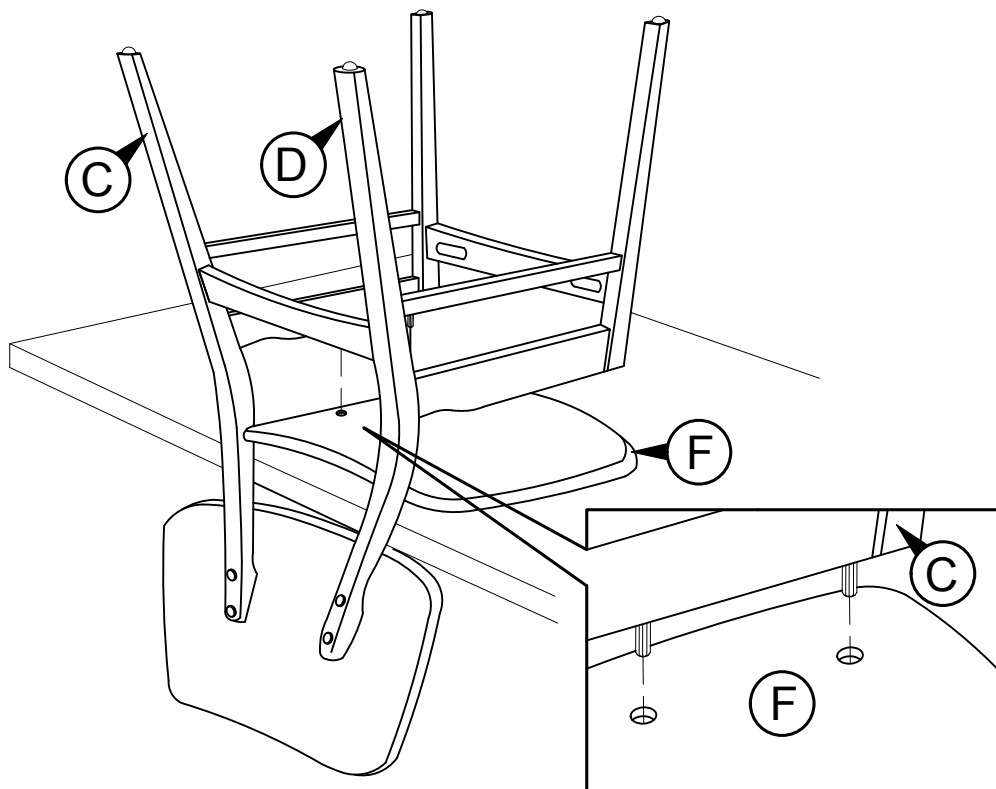

STEP 8 : Assemble the seat frame (C&D) to the Cushion Seat (F) by using a screwdriver with hardware 4 and 5.

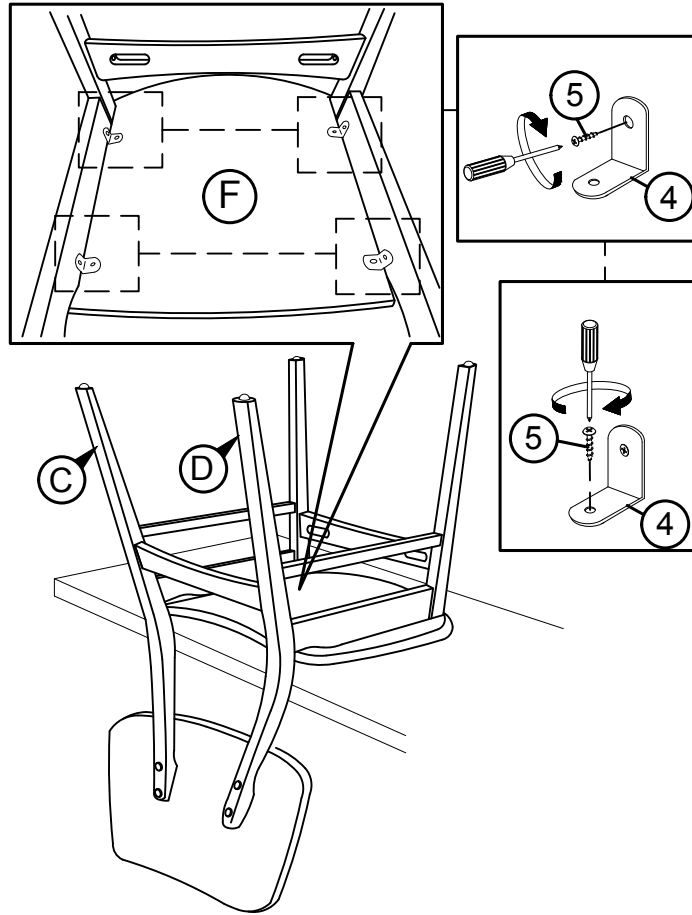

STEP 9 : Place the chair right side up and the assembly is complete.

