

# ASSEMBLY INSTRUCTIONS

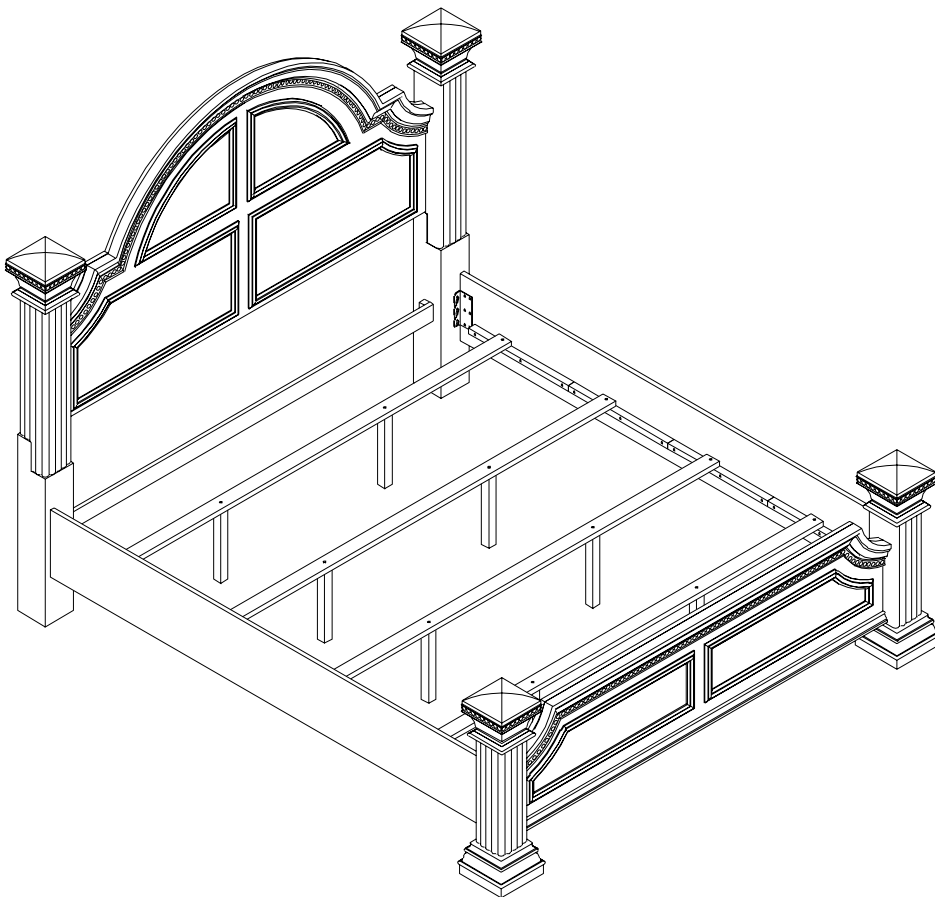

## TOOLS REQUIRED



Allen Wrench  
(Included)



Phillips  
Screwdriver  
(Not Included)



3 - People  
Recommended

## ASSEMBLY RATING



EASY —————> DIFFICULT

The Assembly Rating is a 5-point system showing the level of effort needed to assemble a specific product.



## CHECK BEFORE STARTING

### Are you missing anything?

Double-check all parts, hardware and accessories listed on Page 6 are accounted for.

### Check out our Quick Tips!

We recommend reviewing the pre-assembly handouts. Even experts need a refresher now and then!

### Should we send any replacements?

Are there any irregularities or flaws in the parts? We can send replacements!

### Prep Time!

Please review the assembly instructions and all diagrams prior to assembling. Set up your workspace by laying the parts and hardware out separately, then begin!

# PRE ASSEMBLY INTRODUCTION

We understand building ready-to-assemble furniture can be a challenging experience for some. To help avoid confusion, we have provided some helpful tips that may speed up the process.



### Teamwork

ALWAYS have at least two people to help with transporting and assembling the product to avoid potential injury and/or damage.



### Suitable Location

Assembling near the area of the intended location is highly recommended.



### Sufficient Space

Make sure you have enough space to move around during the assembly.



### Avoid Scratches

Use cardboard, blankets or a carpeted area while assembling furniture to prevent scratches.



### Flat Surface

Make sure the furniture rests on a flat and level surface with each leg evenly touching the floor.

# ASSEMBLY AND CARE ADVICE



**FAILURE TO FOLLOW THE GUIDELINES BELOW MAY RESULT IN INJURY AND/OR PROPERTY DAMAGE.**



Position each part correctly and insert screws or bolts into their respective holes.



Turn clockwise to tighten and only tighten when step is completed or when instructed to do so.



Use the appropriate hand tools or power tools for assembly. Select steps, such as tightening screws and/or bolts, may require hand tools to avoid causing damage during assembly.



Save the instructions and store any supplied tools for later maintenance.



After two weeks, check and tighten any loose hardware and repeat again every six months thereafter.

**IT IS THE USER'S RESPONSIBILITY TO MAINTAIN THE FURNITURE. THE HARDWARE MAY LOOSEN OVER TIME AND MAY CAUSE THE FURNITURE TO BE WOBBLY AND UNABLE TO SUPPORT ITS INTENDED WEIGHT CAPACITY. THIS MAY LEAD TO COLLAPSE AND MAY CAUSE SERIOUS INJURY.**

# BED



- Please keep instructions for future reference.
- Check the quantity and irregularity of parts and hardware before you start.

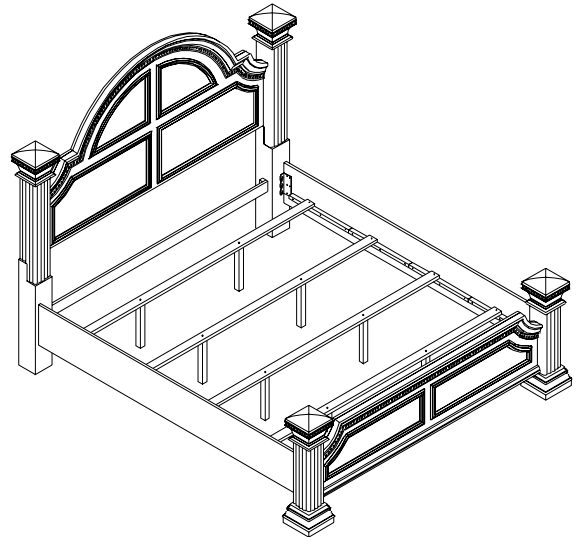

## PARTS

#1 1pc



Headboard

#2 4pcs



Finial

#3 2pcs



HB Leg(L&R)

#4 1pc



Support Rail

#5 1pc

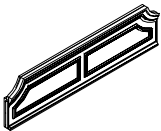

Footboard

#6 2pcs



FB Post(L&R)

#7 2pcs



FB Leg

#8 4pcs



Slat

#9 8pcs

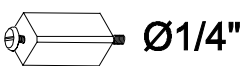

Slat Support  
35x35x300mm

#10 2pcs

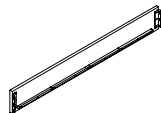

Side Rail

## HARDWARE

#A 12pcs

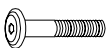

Bolt  
Ø1/4" x 2 1/2"

#B 4pcs

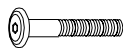

Bolt  
Ø1/4" x 1 3/4"

#C 16pcs



Lock Washer  
Ø1/4"x10mm

#D 12pcs



Flat Washer  
Ø1/4"x19mm

# HARDWARE

#E 4pcs



Flat Washer  
Ø1/4"x13mm

#F 2pcs



Allen Key M4

#G 12pcs



Screw  
#4 x 35mm

#H 12pcs

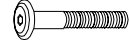

Bolt  
Ø5/16" x 1"







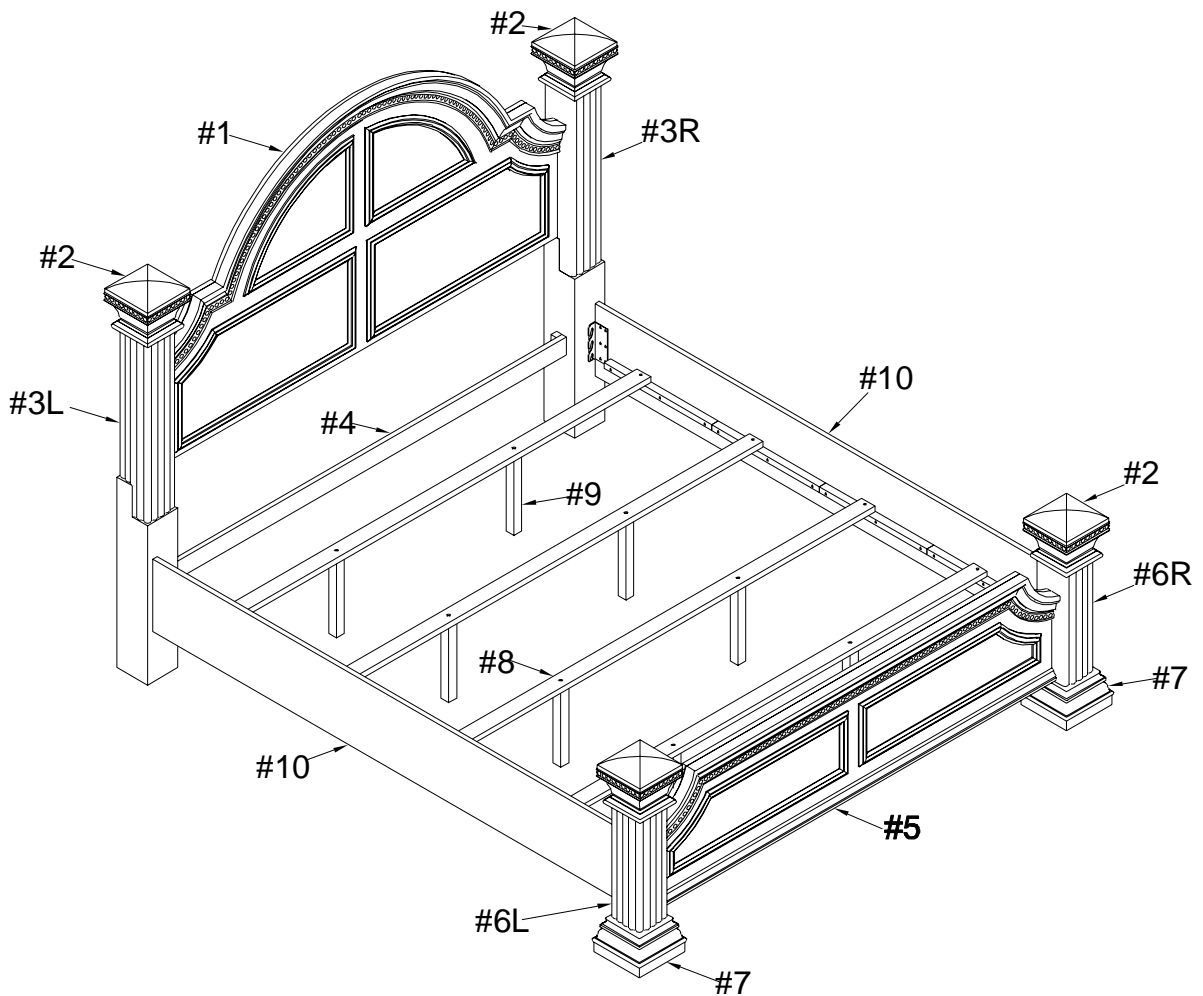







#I 8pcs



Screw  
#4 x 30mm

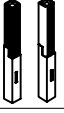
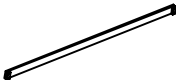
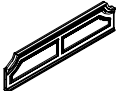

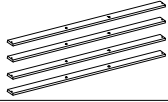
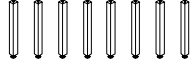
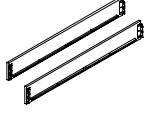
# is packed in 3 cases

Carton	Disignation	Part	Hardware
	Headboard	#1 	 #A x 12pcs  #B x 4pcs  #C x 16pcs  #D x 12pcs  #E x 4pcs  #F x 1pc  #G x 12pcs  #I x 8pcs
	Finial	#2 	
	Headboard Leg (L&R)	#3 	
	Support Rail	#4 	
	Footboard	#5 	
	Footboard Post (L&R)	#6 	
	FB Leg	#7 	
	Slat	#8 	
	Slat Support	#9 	
	Side Rail	#10 	 #F x 1pc  #H x 12pcs

# ASSEMBLY INSTRUCTIONS

## 1

- Part #1 x1pc
- Part #2 x2pcs
- Part #3 x2pcs
- Hardware #A x6pcs
- Hardware #C x6pcs
- Hardware #D x6pcs
- Hardware #G x4pcs

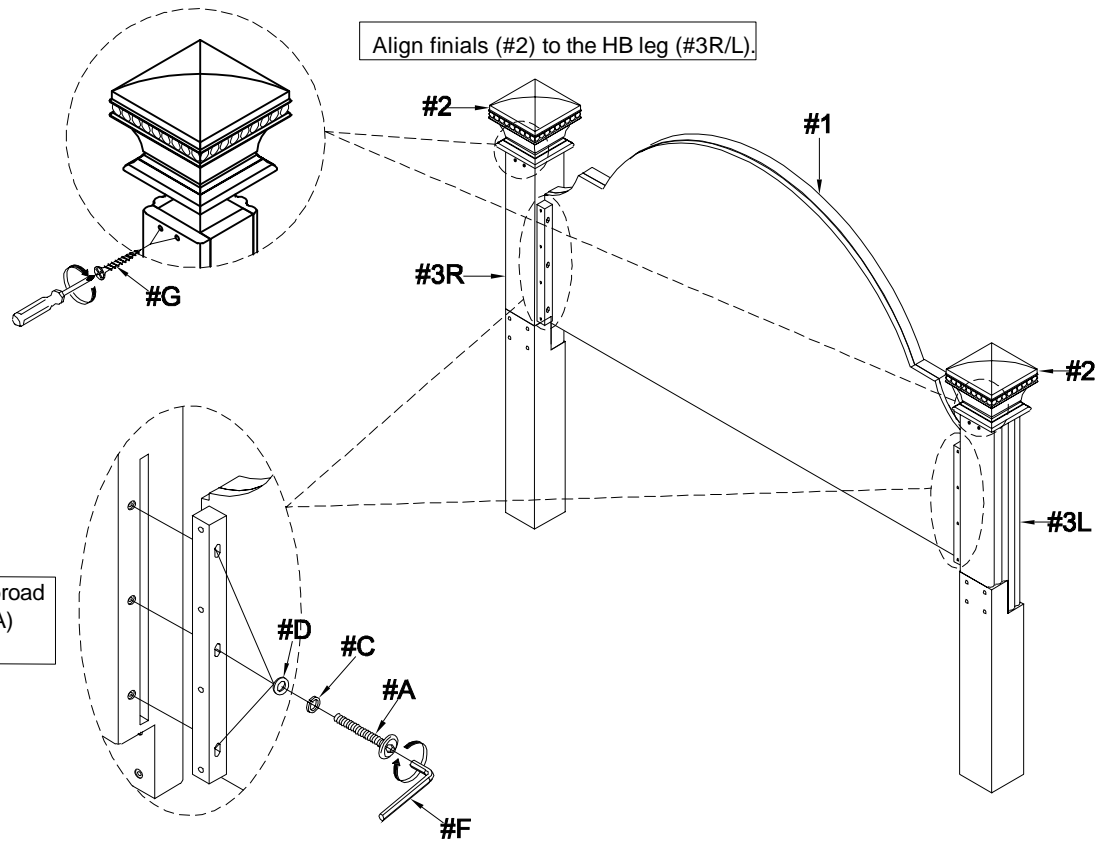

## 2

- Part #4 x1pcs
- Hardware #B x4pcs
- Hardware #C x4pcs
- Hardware #E x4pcs

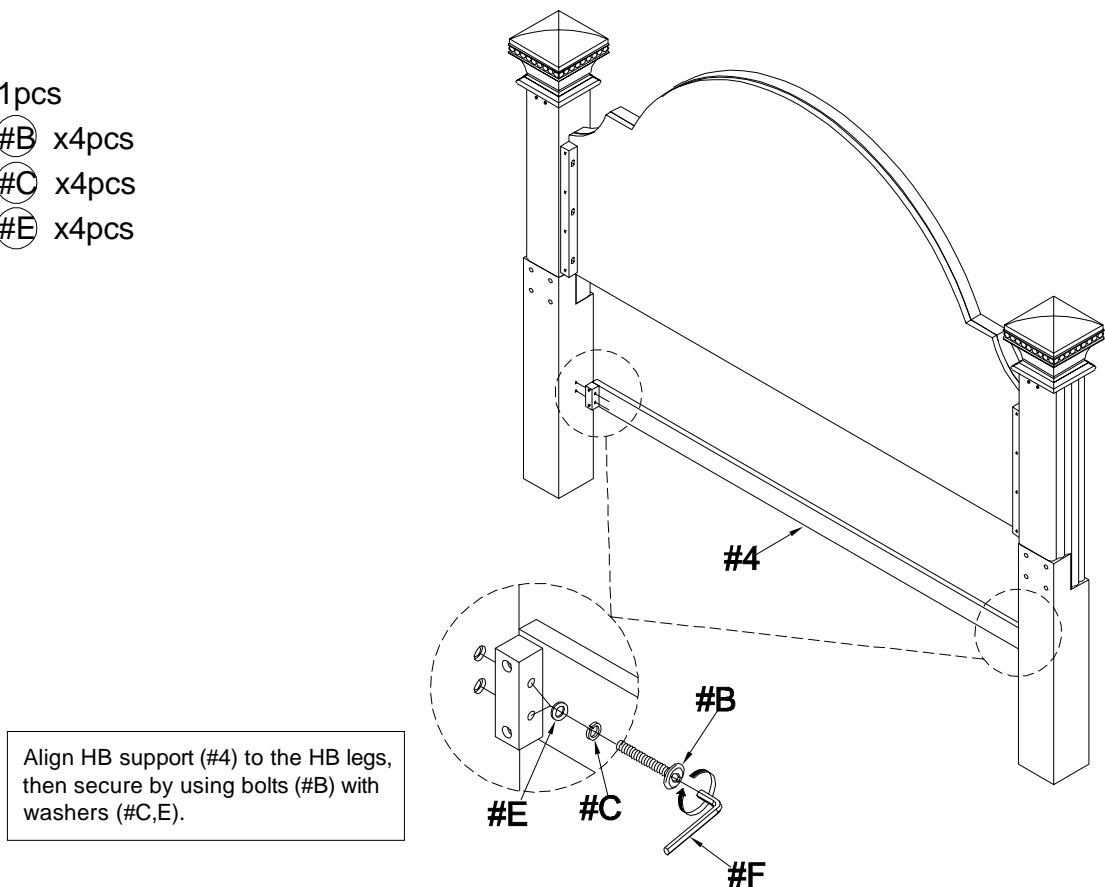

# ASSEMBLY INSTRUCTIONS

## 3

Part #2 x2pcs

Part #5 x1pc

Part #6 x2pcs

Hardware #A x6pcs

Hardware #C x6pcs

Hardware #D x6pcs

Hardware #G x4pcs

Align footboard (#5) to the FB legs (#6R/L), then secure by using bolts (#A) with washers (#C,D).

Align finials (#2) to the FB legs (#6R/L), then secure by using screws (#G).

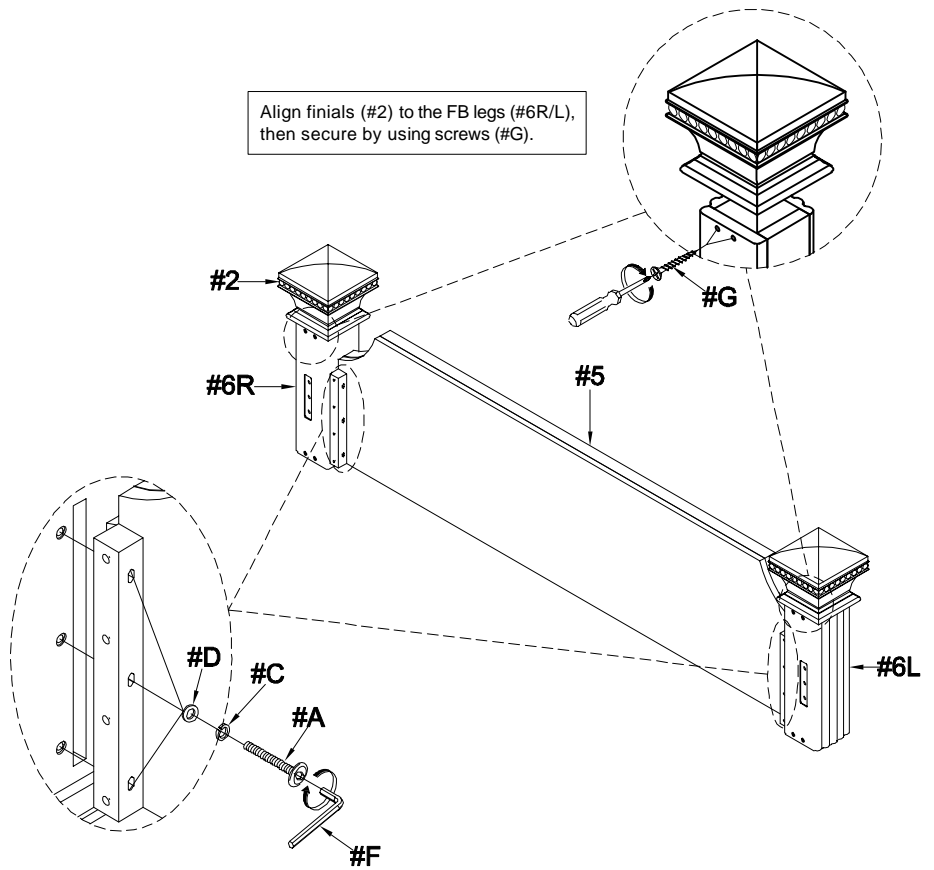

## 4

Part #7 x2pcs

Hardware #G x4pcs

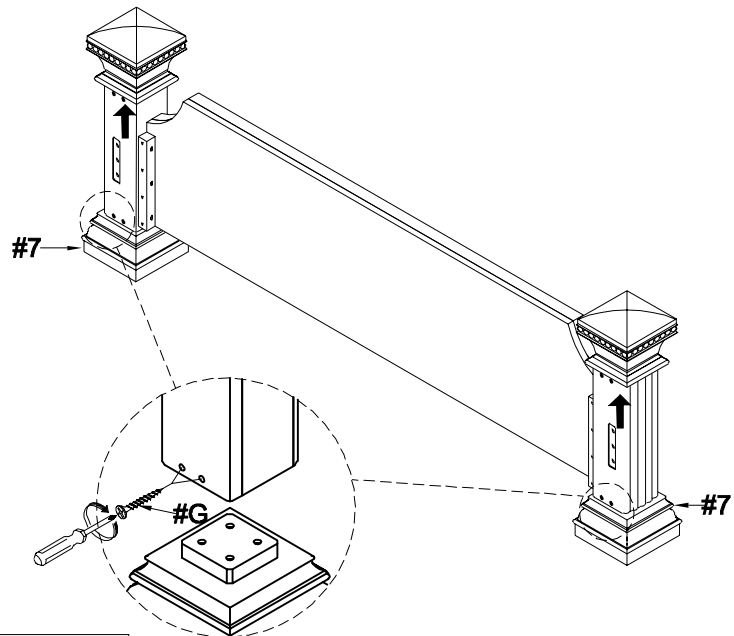

Align FB leg (#7) to the footboard, then secure by using screws (#G).

# ASSEMBLY INSTRUCTIONS

## 5

Part #10 x2pcs  
Hardware #H x12pcs

Align the side rails (#10) to the headboard (#1) and footboard(#5), then secure by using bolts (#H).

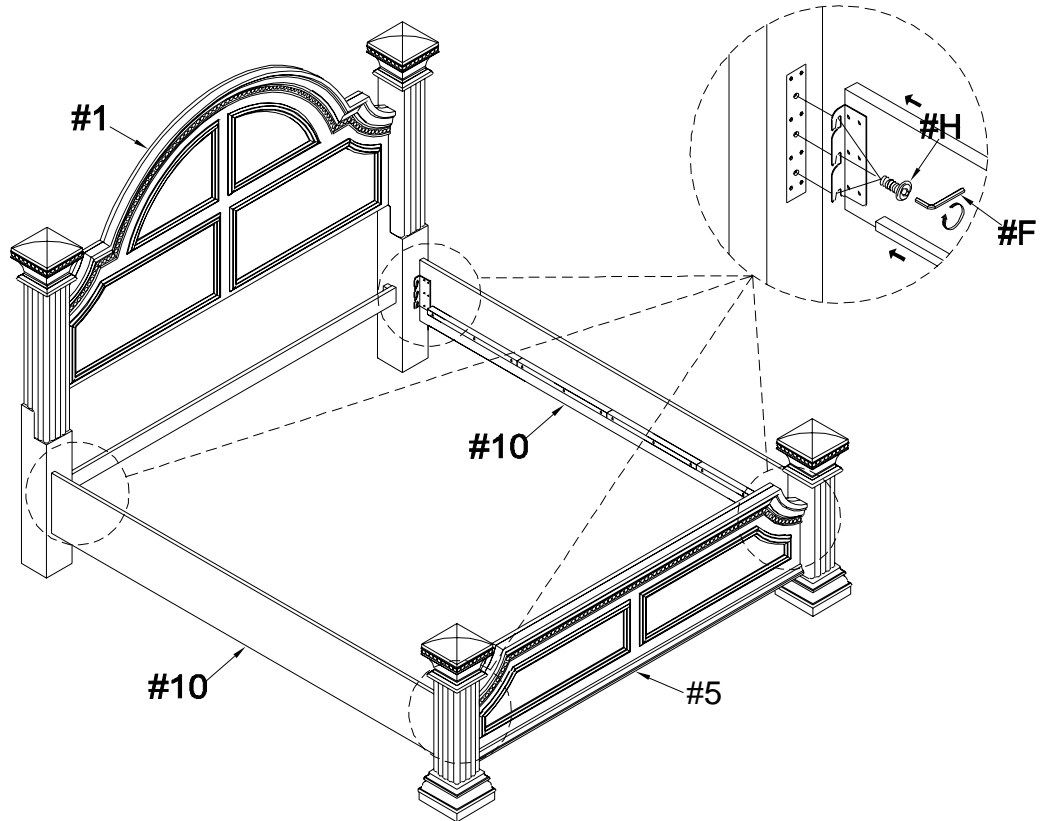

## 6

Part #8 x1pc  
Part #9 x2pcs

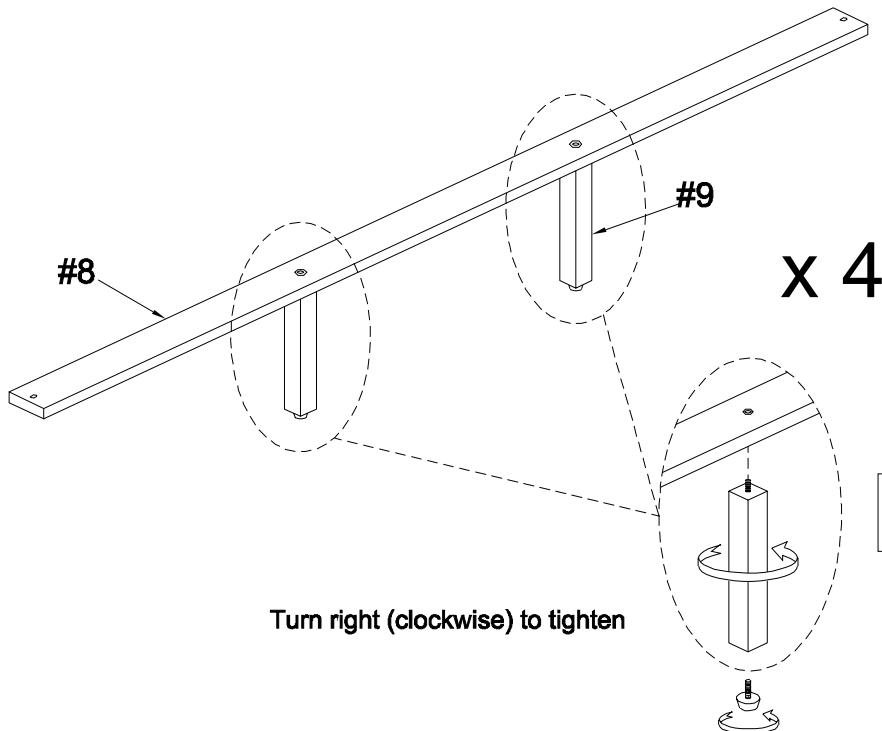

Attach supports legs (#9) to the slats (#8).

Turn right (clockwise) to tighten

# ASSEMBLY INSTRUCTIONS

7

Hardware (#1) x8 pcs

Turn right (clockwise) to tighten

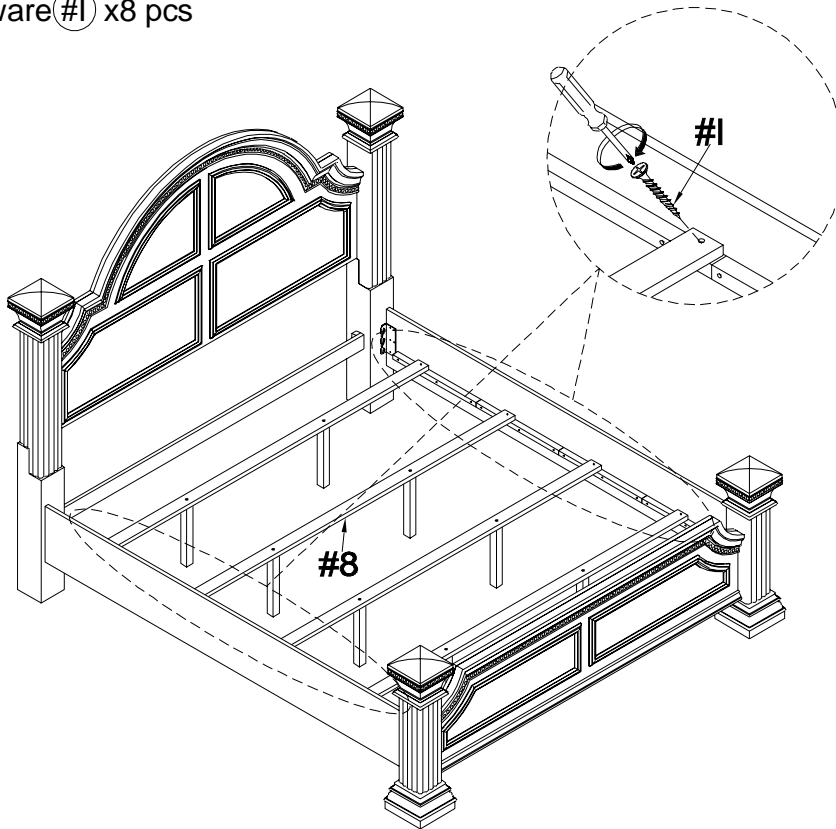

Align slats (#8) to the side rails, then secure by using screws (#1).

8

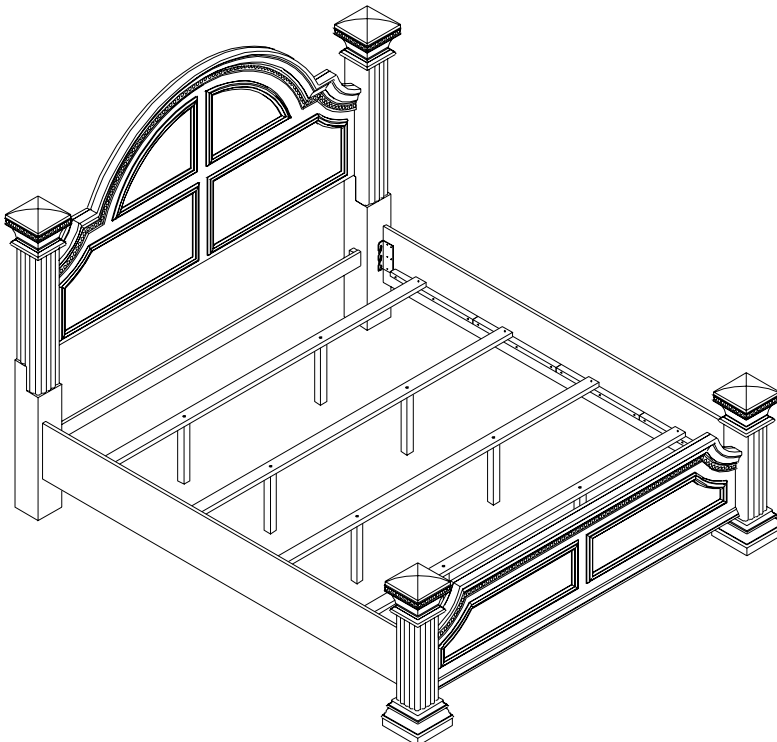

## ASSEMBLY COMPLETED



Please ensure the furniture rests on an even and flat surface. If the product wobbles or feels loose, double-check all bolts and/or screws are properly tightened and secured.



### Keep this handy!

Please retain this instruction manual and any order-related information for future reference.



### Lift, don't drag!

To avoid damage to product please always LIFT the product when transporting or adjusting the placement.