

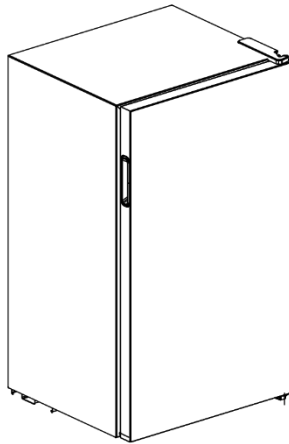

**Beverage Cooler
Instruction Manual**



**Model number:
K48BC101 B / SS**

For Customer Services & Spare Parts please call 0345 208 8750
or visit us at www.kuhla.co.uk

**IMPORTANT:
RETAIN FOR FUTURE REFERENCE**

Contents

Safety Instructions	3-4
Electrical Safety	5
Transportation & Handling	5
Installing & Switch on your Appliance	6-7
Before Switching On	7
Product Overview	8
Unit & Spare Parts	8
Usage	9
Interior Light	10
Bulb replacement	10
Shelves	11
Door reversal	12-14
Energy Saving Advice	15
Cleaning and Maintenance	16
Connection to the Mains Supply	17-18
Troubleshooting	19-20
Guarantee	21
Technical Specification	22
Product Fiche	23

Safety Instructions

Important note: Please read this booklet before installing and switching on this appliance. The manufacturer assumes no responsibility for incorrect installation and usage as described in this booklet.

 **Warning:** When positioning the appliance, ensure the supply cord is not trapped or damaged.

 **Warning:** Do not locate multiple portable socket-outlets or portable power suppliers at the rear of the appliance.

- This model uses natural refrigerant gas as part of its cooling system. This gas is known as R600a (Isobutene) and is environmentally friendly but can be combustible. Care should therefore be taken when handling or transporting the product to ensure that none of the refrigeration circuit components are damaged,
- Do not obstruct ventilation openings in the appliance
- The appliance must not be placed or rested on its power cord.
- Do not use mechanical devices or other artificial means to accelerate the defrosting process, such as a heater or a hair dryer.
- Do not use electrical appliances in the refrigerator compartment of the appliance.
- If this appliance is to replace an old refrigerator with a lock, the lock must be removed as a safety measure before storing it or disposing of it. This is to protect children from locking themselves inside the appliance.
- Old refrigerators and freezers contain insulation gases and refrigerant, they must be disposed of properly. Contact your local authority or your dealer if you have any questions. Please ensure that you do not damage the scrap unit prior to being picked-up by the relevant waste disposal service.
- Do not use adaptors or extension leads when connecting the appliance to the electrical power supply

- Do not plug in damaged plugs.
- Do not pull, twist or damage the power cable.
- Do not plug-in or un-plug the appliance with wet hands to prevent electrical shock.
- This appliance can be used by children aged from 8 years and above and persons with reduced physical, sensory or mental capabilities or lack of experience and knowledge if they have been given supervision or instruction concerning use of the appliance in a safe way and understand the hazards involved. Children should not play with the appliance.
- Children aged from 3 to 8 years are allowed to load and unload this appliance.
- This appliance is designed to be used by adults, do not allow children to play with the appliance or let them hang over the door.
- Do not place explosive or flammable material in your appliance for your own safety.
- Do not cover the body or the top of the appliance
- Fix down the accessories in the appliance during transportation to prevent damage to them.
- If the appliance is left empty for long periods, switch off, defrost, clean, dry and leave the door open to prevent mould developing within the appliance.
- This refrigerating appliance is intended to be used exclusively for the storage of beverages.
- This refrigerating appliance is not intended to be used as a built-in appliance.
- This refrigerating appliance is not suitable for freezing foodstuffs.

Electrical Safety

THIS APPLIANCE MUST BE PLUGGED INTO AN EARTHED SOCKET

- Before switching on, make sure that the voltage of your electricity supply is the same as that indicated on the rating plate. This product is designed to operate on AC220V – 240V; 50Hz. Connection to any other power source may damage the unit.
- This product may be fitted with a non re-wireable plug. If it is necessary to change the fuse in the plug, the fuse cover must be refitted. If the fuse cover becomes lost or damaged, the plug must not be used until a suitable replacement is obtained.
- If the plug has to be changed because it is not suitable for your socket, or becomes damaged in any way, it should be cut off and an appropriate plug fitted following the wiring instructions. This should be carried out by a qualified electrician. The plug removed must be disposed of safely, as insertion into a 13 Amp socket is likely to cause an electrical hazard.

Transportation and Handling

For safe lifting, tilt the appliance backwards by no more than 45 degrees, hold the base and rear corners of cabinet. Lift the refrigerator carefully. Never use the door handles for lifting. To move the refrigerator on a flat level surface, tilt it slightly backwards and push backwards.

This unit is heavy and could cause injury – ensure there are adequate people present to move the appliance.

Installing and Switching on Your Appliance

- Operating voltage for your appliance is AC220V-240V at 50Hz.
- Before plugging in the power supply, ensure that the voltage on the rating label corresponds to the working voltage of your electrical system in your home.
- Insert the plug into an efficient Ground (Earth) connection. If the socket has no Ground (Earth) contact or the plug does not match, we suggest you call an authorised electrician for assistance.
- Place your appliance in an area that is not exposed to direct sunlight.
- Your appliance should be placed at least 10cm away from stoves, ovens and other heating cores.
- This appliance should never be used outdoors or left in the rain.
- When your appliance is placed next to a chest freezer or freezer, there should be at least 10cms between them to prevent humidity on the outer surface.
- Do not place anything on your appliance and install the unit in a suitable place so that there is at least 30cm clearance above the appliance.
- If placing your appliance next to kitchen cabinets, leave 5cm between them.
- The rear of the appliance should be at least 6cm away from the back wall.
- The appliance must be used in the vertical position and on a flat surface.
- To level the appliance, use the adjustable feet on the appliance.
- Do not place your appliance on a carpeted surface as this will prevent adequate ventilation.
- This appliance should only be placed on a flat, firm surface.
- Choose a dry and well-ventilated space.
- The appliance should be positioned so that the plug is easily accessible.
- This appliance is not suitable for use in garages, outbuildings or rooms that do not comply with the ambient temperature requirements set out in the Product Fiche.



! WARNING! During use, service and disposal of the appliance, please pay attention to symbol similar to the one shown, which is located on rear of the appliance (rear panel or compressor) and with a yellow or orange colour. It's risk of fire warning symbol. There are flammable materials in refrigerant pipes and compressor. Please be far away from fire source during use, service and disposal.

Before Switching On

- Before using your appliance, add a teaspoon of bicarbonate of soda to warm water and with a damp cloth wipe down all parts of the new appliance, then repeat the process with a clean damp cloth and dry. **(ensure the appliance is not connected to the power when performing this task).**
- Remove all transport tapes and foam protection pieces . Clean the interior with a cloth dampened in lukewarm soap and water. Wipe with clean water and wipe dry.
- There may be an odour when you first switch on the appliance, it will disappear when the appliance starts to cool.
- When the appliance has been positioned, adjust the feet to ensure the unit is stable. This is essential to ensure quiet running and proper door opening /closing.
- Connect to the electrical socket but do not switch the power to the appliance on for at least 3 hours. The coolant within the product needs time to settle after it has been transported and put in to position, failure to do this will affect the cooling performance of your appliance.
- Once the appliance has settled, locate the thermostat dial on the product (this is inside the appliance at the top behind the LED light) and set between settings "5" and "6" and switch on the power. The compressor will begin to work. Close the door.
- You may hear faint gurgling or bubbling sounds when the refrigerant is pumped to the cooling system and through the coils or tubing at the rear of the appliance. When the compressor is in operation you may hear a slight whirring sound or pulsating noise. The thermostat controls the operation of the compressor, and you may hear a slight click as it cycles in and out.
- To save energy, you should minimize the frequency and duration of door opening.

Product Overview

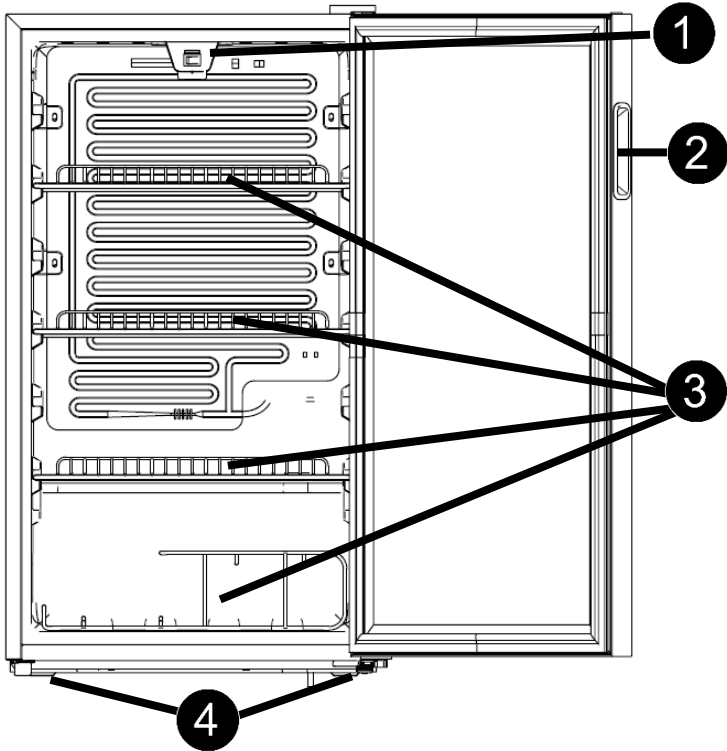

1. Temperature & light switch
2. Recessed handle
3. Shelves (3 x flat & 1 x bottle)
4. Adjustable feet

Parts may vary according to the appliance model.

Unit Parts & Spare Parts

Before installation, check that all parts detailed in the product overview are present. If any parts are missing, please contact the Customer Service team on **0345 208 8750** or visit us at **www.kuhla.co.uk**

Usage

! Allow to stand for a minimum of 3 hours before plugging in to the mains

The temperature in the appliance is controlled by the temperature control dial located inside the appliance at the top. Rotate the control dial left or right to regulate the temperature inside the cooler.

On the temperature control, OFF is off, 1 is the warmest setting and 6 is the coldest setting. **Under normal conditions the temperature control should be set between settings 5 and 6.** Once the temperature control has been set, close the door and plug in the appliance. We recommend that the door is not opened for a minimum of 4 hours to allow the appliance to reach the standard operating temperature.

Note: The standard operating temperature for the cooler compartment should be between 5°C and 18°C.

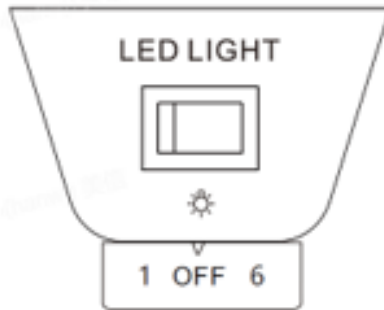

Note:

- Due to the air circulation the upper shelves will be at a slightly higher temperature than the lower shelves
- Do not let bottles or cans touch the rear of the cavity as this will adversely affect the air flow and therefore the temperature of the appliance.
- The temperature of items stored in the appliance and how often the door is opened affects the temperature in the cooling compartment. If required, change the temperature setting.

Interior Light

- The appliance has an interior light and this can be turned on and off, by pressing the light button that is located inside the appliance at the top.

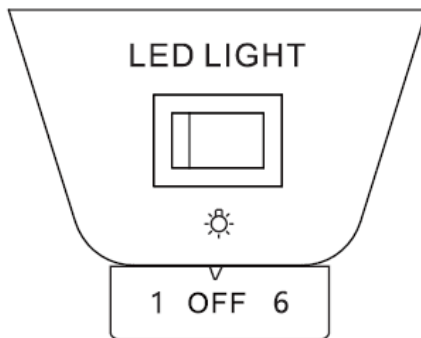

Bulb Replacement

The light is an energy efficient, long life LED. Therefore should not need replacing throughout the life of the product however if it does it has to be replaced by a qualified engineer.

The following symbol indicates that the light source in this appliance should only be replaced by a qualified engineer:

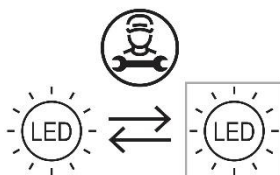

Shelves

- Any of the shelves can be removed, to accommodate larger bottles.
- Removing a shelf – remove all of the bottles from the shelf that you want to remove. Lift the shelf upwards and then gently pull the shelf away from the appliance.
- Replacing a shelf - Place the shelf back into a supporting guide slot and push it back as far as it will go.

Important: Whilst the beverage cooler can store larger bottles, you must make sure that they do not prevent the door from shutting properly.

- Always check that you can close the door without it touching or hitting any of the bottles, before shutting it.
- When loading several beverages at once, it will take longer for the appliance to cool the individual bottles or cans.

Door Reversal

You will need to tilt the cooler backward to access the lower hinge which holds screws. Do not tilt more than 45 degrees and do not lay the cooler flat on its side.

For your own safety, a minimum of 2 people should lift or tilt this product.

Tools Required: Cross headed screwdriver, flat headed screwdriver and hexagonal spanner.

Reversing the door:

1. Remove the top plastic hinge cover and set aside. Then remove the 3 screws from the top hinge with a Phillips head screwdriver or a spanner. Support the door and remove the hinge and then the door. Place the door on a cushioned surface.

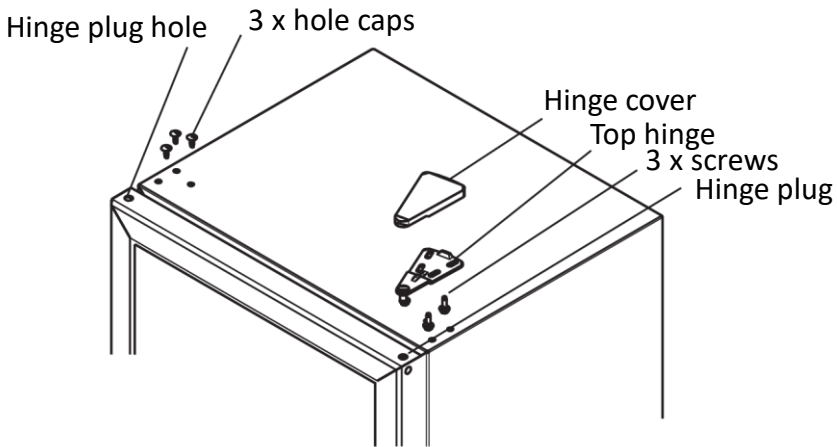

Door Reversal

2. Tilt the appliance carefully and remove the bottom hinge by removing the screws with a Phillips head screwdriver or a spanner. Also remove the adjustable foot on the opposite side.

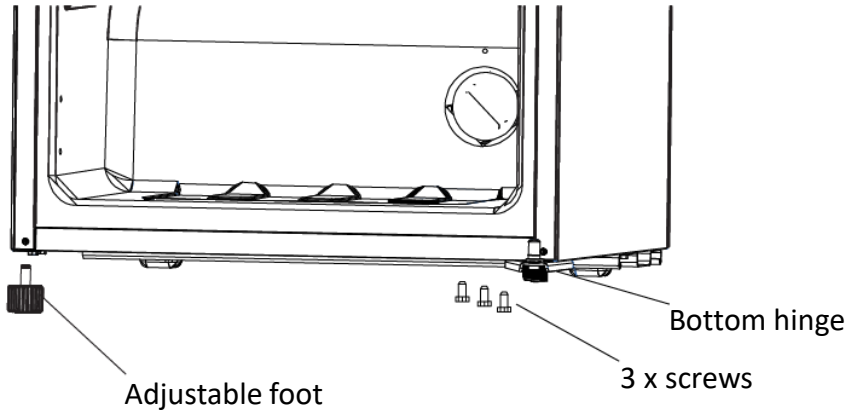

3. Refit the bottom hinge to the opposite side and refit the adjustable foot to the opposite side.

Door Reversal

4. On the bottom of the door swap the bottom door stopper over to the opposite side, the hinge plug will need to be swapped to the opposite side on the door stopper. On the top of the door swap the hinge plug over to the opposite side.

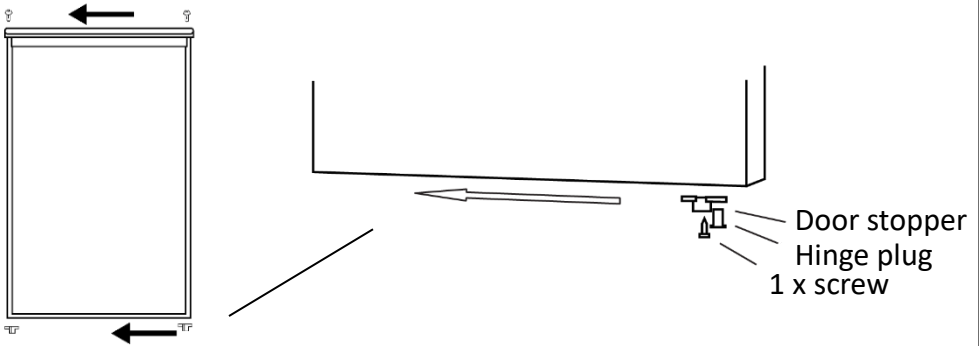

5. Place the door back on to the bottom hinge, and put the top hinge into the top of the door. Ensure that the door is aligned horizontally and vertically so that the seals are closed before tightening the top hinge to the appliance.

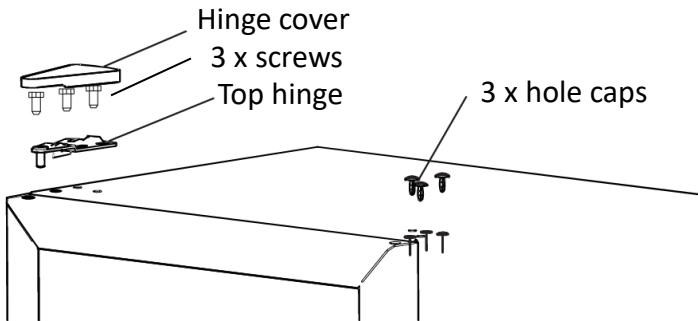

Note:

- Check that the door opens and shuts correctly after you have completed the door reversal process.
- The appliance must now be upright for a minimum of 3 hours before turning it on.

Energy Saving Advice

- Do not install the appliance close to sources of heat, such as a cooker, dishwasher or radiator.
- Locate the appliance in a cool well-ventilated room and make sure that the air vents are clear.
- Try to avoid keeping the doors open for a long time, warm air will enter the cabinet and may cause a build-up of ice as well as affecting the energy consumption. Ensure there are no obstructions preventing the doors from closing properly.
- Ensure that the door seals are clean and there are no tears or splits.
- Do not overload the appliance: the cooling air that circulates to keep the appliance cold gets blocked and pockets of warm air form.
- The shelves are placed in factory mode this delivers the most energy efficient usage for this appliance.

Maintenance & Cleaning

Disconnect the appliance from the power supply before cleaning.

Internal Cleaning

- Do not pour water over the appliance.
- The cavity should be cleaned periodically using a solution of bicarbonate of soda and lukewarm water (5ml to 0.5 litre of water)
- Clean the accessories separately with soap and water. Do not put them in the dishwasher.
- Do not use abrasive products or detergents.
- After washing, rinse with clean water and dry carefully.
- When you have finished cleaning reconnect the plug with **dry hands**.

External Cleaning

- Wash the outer cabinet with warm soapy water. Do NOT use abrasive products.
- There are sharp edges on the underside of the product so care should be taken when cleaning.
- Once or twice a year dust the rear of the appliance and the compressor at the back of the appliance, with a brush or vacuum cleaner, as an accumulation of dust will affect the performance of the appliance and cause increased energy consumption.

When the appliance is not in use

When the appliance is not in use for long periods, disconnect from the electricity supply, empty all of the contents and clean the inside. Leave the door open to prevent the build-up of odours.

Connection to the mains supply

WARNING- THIS APPLIANCE MUST BE EARTHED

This appliance is designed to operate from a mains supply of AC220V - 240V; 50Hz.
Check that the voltage marked on the product corresponds with your supply voltage.

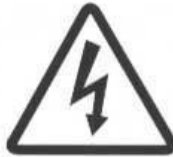

DANGER
Electric
Shock Risk

Connection to the mains supply

For UK use only – Plug fitting details (where applicable):

As the colours of the wires in the mains lead of this appliance may not correspond with the coloured markings identifying the terminals in your plug, proceed as follows:

The GREEN/YELLOW wire is the EARTH and must be connected to the terminal which is marked with the letter E or by the earth symbol or coloured GREEN or GREEN/YELLOW.

The BLUE wire is the NEUTRAL and must be connected to the terminal marked with the letter N or coloured BLACK. The BROWN wire is the LIVE wire and must be connected to the terminal marked with the letter L or coloured RED.

Always ensure that the plug cord grip is fastened correctly.

If a 13A (BS1363) fused plug is used it must be fitted with a 13amp fuse conforming to BS1362 and be BSI or ASTA approved.



DANGER
Electric
Shock Risk

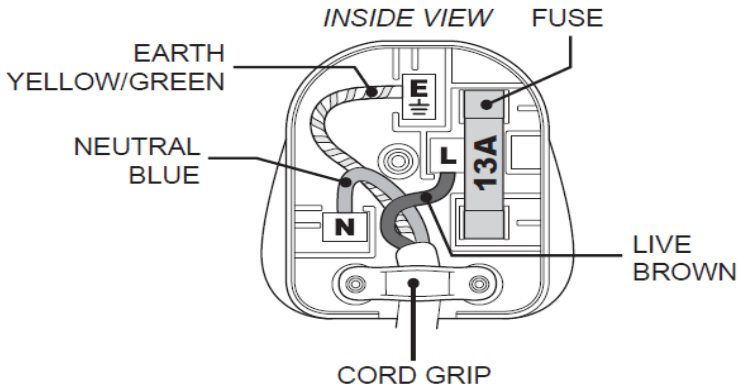

Troubleshooting

Problem	Solution
<p>The appliance doesn't work</p>	<p>Check that the appliance is switched on.</p> <p>Check that there has not been a power cut.</p> <p>Check that the plug is not faulty.</p> <p>Check that the fuse has not blown.</p> <p>Check that the voltage is correct for the appliance.</p> <p>Check the keypad is not locked</p>
<p>The temperature inside the appliance is not cold enough</p>	<p>Check that there are not too many bottles in the appliance.</p> <p>Check that the temperature is set to a suitable temperature.</p> <p>Check that the appliance is not placed in direct sunlight, or too near to a heating source.</p> <p>Check that the ambient temperature is within the operation limits of the appliance.</p> <p>Opening the doors frequently will also reduce the temperature within the appliance.</p> <p>Check that the door has not been left open or check that the door gasket is clean and undamaged.</p>
<p>The temperature within the appliance is too cold.</p>	<p>Increase the working temperature</p>
<p>The inner surfaces of the appliance are wet</p>	<p>Caused by condensation - dry the inside of the appliance.</p>
<p>The outer surfaces of the appliance are wet</p>	<p>Caused by condensation - dry the outer of the appliance carefully.</p>

Troubleshooting

Problem	Solution
Unusual noises	Check that the appliance is on a flat, level surface and is stable. Check the spacing's around the appliance and ensure it is not touching other items.
Smell/odour	Check that no bottles have leaked or any stagnant liquid is at the bottom of the appliance. Clean if required.

Guarantee

This product is guaranteed for 12 months from the date of the original purchase. If any defect arises due to faulty materials or workmanship the faulty product must be returned to the place of purchase.

Refund or replacement is at the discretion of the retailer.

The following conditions apply:

- The product must be returned to the retailer with the original proof of purchase.
- The product must be installed and used in accordance with the instructions contained in this instruction guide and any other instructions for use which have been supplied.
- It must be used for domestic purposes only and for its intended use.
- This warranty does not cover wear and tear, damage, misuse or consumable parts.

This does not affect your statutory rights.

Technical Specification

Model number	K48BC101B / K48BC101SS
Rated Voltage	220V – 240V ~ 50Hz
Capacity	93L
External Dimensions(HxWxD)	845mm x 470mm x 440mm

Product Fiche

Model	K48BC101B / K48BC101SS
Fresh Food Storage Compartment Volume (L)	N/A
Frozen Food Storage Volume (L)	N/A
Storage Temperature (°C)	5 – 18
Energy Consumption (kWh/per year)	81
Energy Consumption (kWh/per year), based on standard test results for 24 hours	
Energy Rating	E
Light Energy Efficiency Class	Exempt
The light source in this appliance should only be replaced by a qualified engineer	
Defrosting Type	Static
Climate Class	SN/N/ST
This appliance is intended to be used at an ambient temperature between 10°C and 38°C	
Airborne Acoustical Noise (dB)	40
Temperature Rise Time	N/A
Freezing Capacity	N/A
Rated voltage	220V- 240V~ / 50Hz
Rated Current	0.7A
Product Dimensions (H x W x D)	84.5 x 47 x 44cm
Total Storage Volume (L)	93L
This appliance is intended to be used exclusively for the storage of wine	No
Built in appliance	No
Net Weight (kg)	29

Class	Symbol	Ambient temperature range (°C)	Information
Extended temperate	SN	+10 to +32	Extended temperate: 'this refrigerating appliance is intended to be used at ambient temperatures ranging from 10°C to 32°C;
Temperate	N	+16 to +32	Temperate: 'this refrigerating appliance is intended to be used at ambient temperatures ranging from 16°C to 32°C;
Subtropical	ST	+16 to + 38	Subtropical: 'this refrigerating appliance is intended to be used at ambient temperatures ranging from 16°C to 38°C;
Tropical	T	+16 to+ 43	Tropical: 'this refrigerating appliance is intended to be used at ambient temperatures ranging from 16°C to 43°C;



Imported by Product Care Trading Limited, Wigan, WN2
4AY/ PCT (NI) Ltd, Belfast, BT5 5AD.

Kuhla Support: call **0345 208 8750** or visit: **www.kuhla.co.uk**

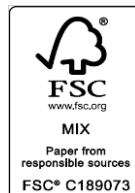
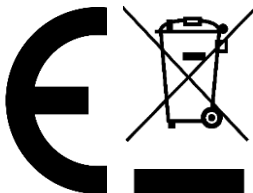

The 'wheellie bin' symbol is known as the 'Crossed-out wheellie bin Symbol'.

When this symbol is marked on a product/batteries, it means that the product/batteries should not be disposed of with your general household waste. Only discard electrical/electronic/battery items in separate collection schemes, which cater for the recovery and recycling of materials contained within. Your co-operation is vital to ensure the success of these schemes and for the protection of the environment. For your nearest disposal facility, visit www.recycle-more.co.uk or ask in store for details.

SEDEX – Connecting businesses and their global suppliers to share ethical data and enabling improvement in ethical performance. Visit www.sedex.org.uk for further information.

We reserve the right, due to possible changes to design, to alter the instruction manual without prior notice.