

INSTALLATION INSTRUCTION

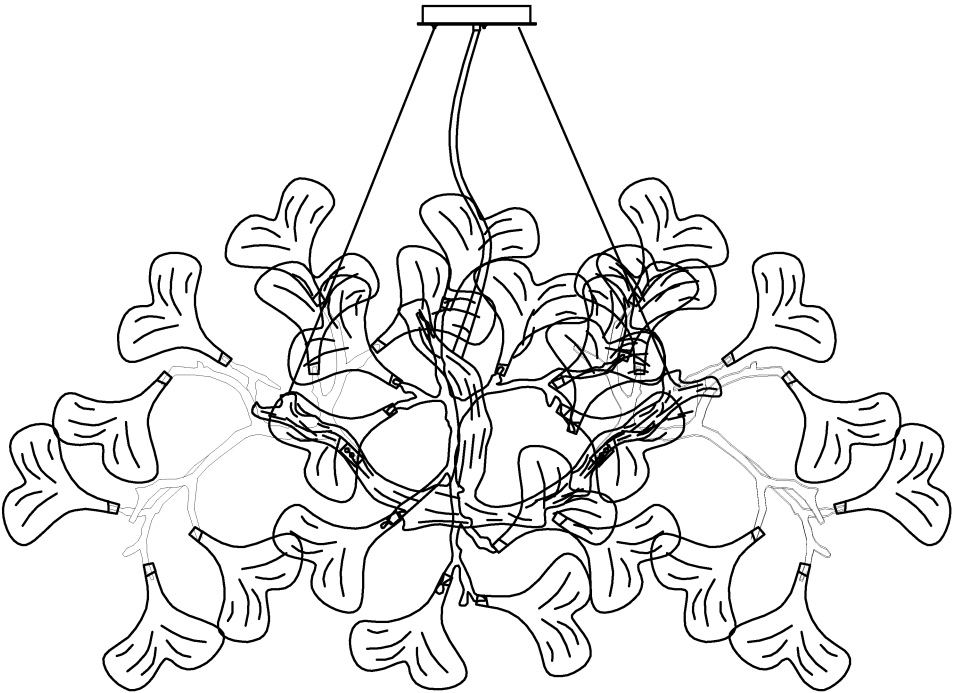

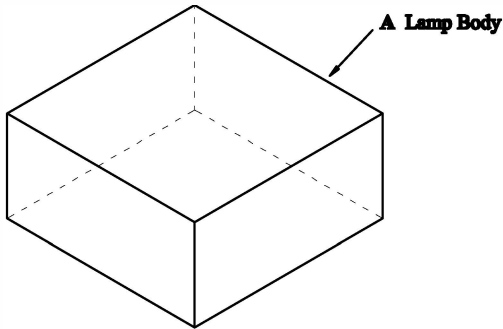

Chandelier Installation and Safety Standards

The installation of a chandelier is a crucial step in ensuring its safety. Chandelier safety standards dictate the process of installation, including the tools and equipment that can be used, the methods of securing the chandelier, and the location of the chandelier.

Securing the chandelier is a crucial step in the installation process. Chandelier safety standards dictate that the chandelier must be securely attached to a suitable support, such as a ceiling joist, to prevent it from falling. This includes ensuring that the support is strong enough to bear the weight of the chandelier, and that the chandelier is properly balanced to prevent it from tipping or swaying. Furthermore, the chandelier must be secured using suitable hardware, such as screws or bolts, that are strong enough to bear its weight. The hardware must be properly installed and tightened to ensure that the chandelier is securely attached. Regular inspections of the hardware are also necessary to detect and repair any damage or wear promptly.

SAFETY INFORMATION

It is important to thoroughly read and understand the entire manual, before assembling, operating, or installing the product,













WARNING

- **TURN OFF ELECTRICITY** before installation, changing bulbs, or cleaning the light fixture.
- This fixture requires **10 pieces G9** bulbs (not included in the product, the maximum wattage for each bulb is 40W, please do not exceed the recommended wattage.
- **A QUALIFIED ELECTRICIAN IS RECOMMENDED FOR INSTALLATION.**
- Do not use corrosive substances such as gasoline or alcohol disinfectants to wipe the lamps, otherwise it will damage the lamps .

PREPARATION

- Before installation, please make sure all the accessories are included (refer to the package content), if there is any part missing, please contact us at the order page, we will arrange the replacement in a timely manner
- **10 pieces of G9** bulbs (Max. 40W) are required (not included in the product)
- For any questions or inquiries, please feel free to contact us at the order page, our customer service team will reply ASAP.

PACKAGE CONTENTS

accessories list				
Ax4 	Bx8 	Cx1 	Dx3 	Ex2 
Fx1 	Gx52 	Hx52 	Ix2 	Jx1 
Kx4 	Lx4 	Mx1 	Nx0	Ox0

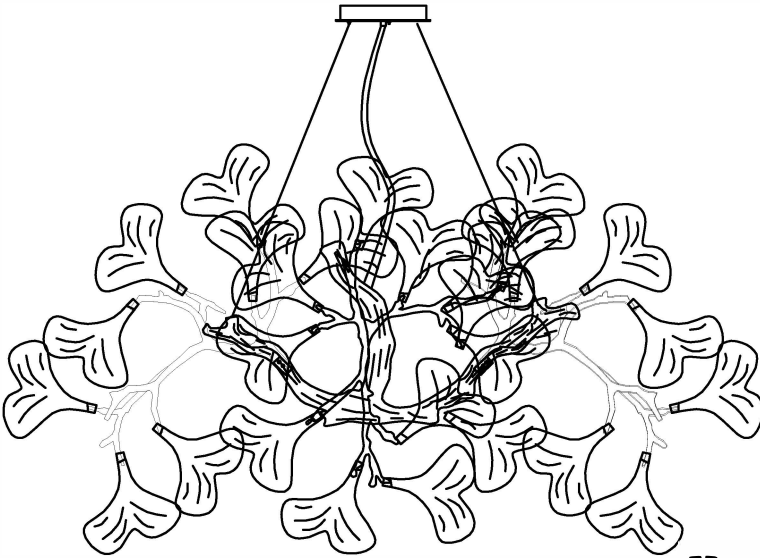

G9 Bulbs-10
(not included)

Please note:

Please check the parts list, if the parts are missing during your actual installation, please contact us, we will help you in time!

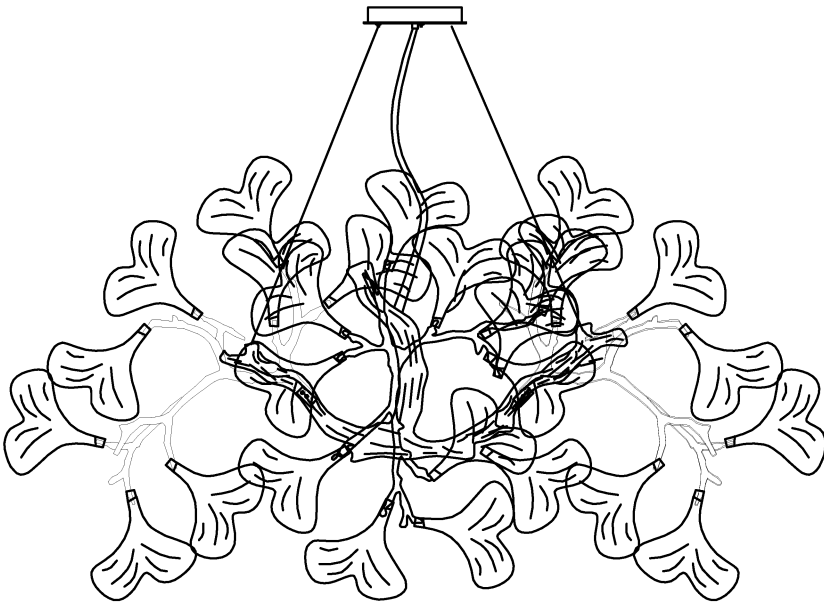

Steps:

1. Take out the lamp body and check the firmness of the lamp body;

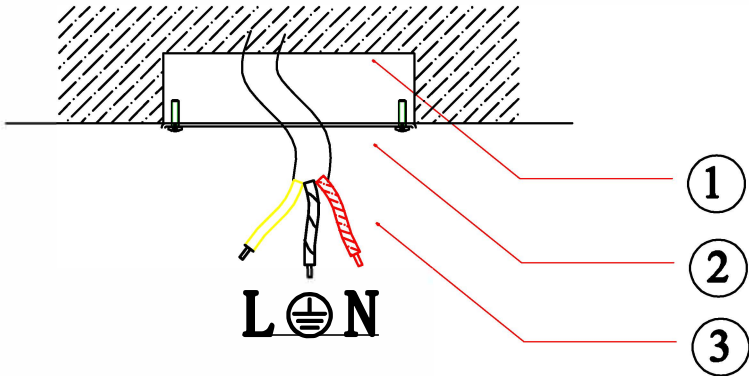
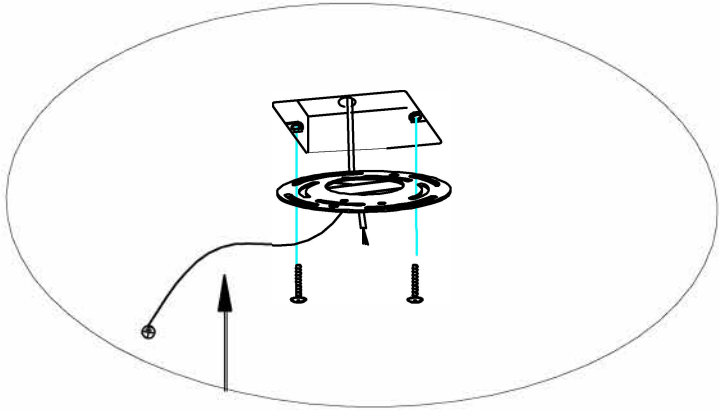

Steps:

- 1. Remove the crossbar from the preassembled mounting base;**
- 2. Lock the crossbar on the junction box with the screw.**

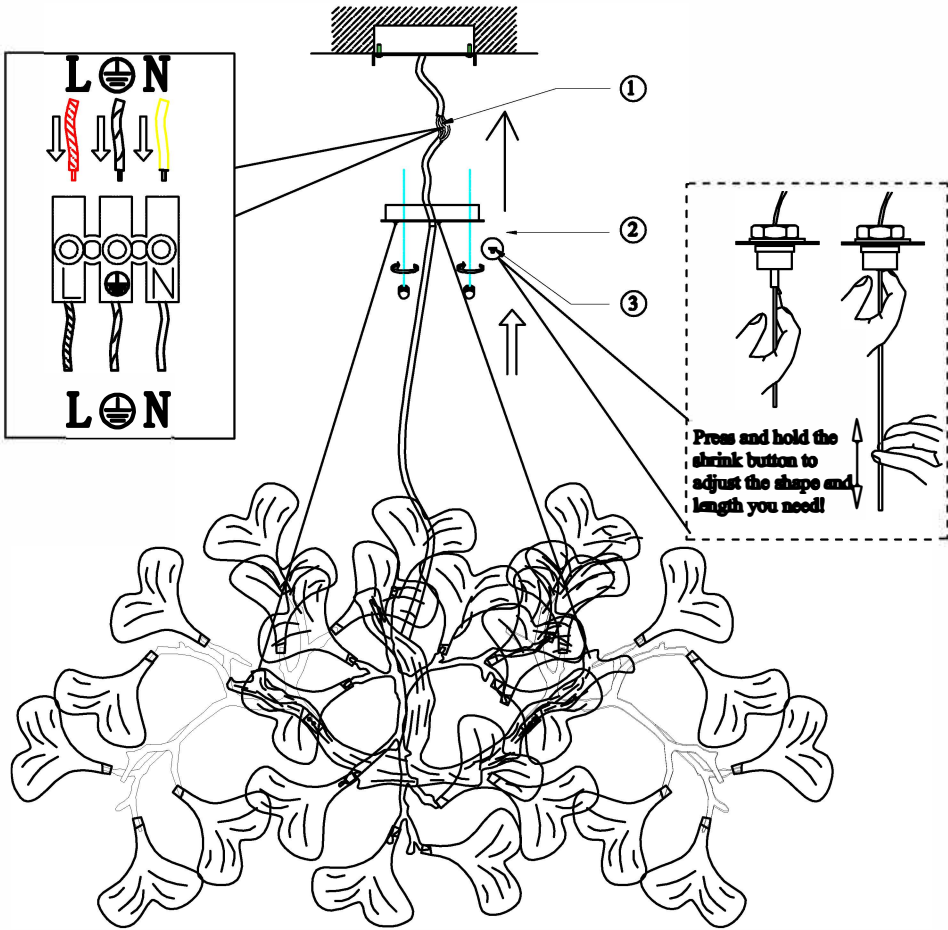

- ① Lift the installed lamp body to the bracket position and connect the wires, then lift it to align with the screw holes.
- ② Use the matching screws to tighten it.
- ③ Adjust the appropriate height of the lamp body according to the picture
- ④ Install the bulbs and test them.

- **Start debugging the lamp shape while ensuring the safety of personnel**

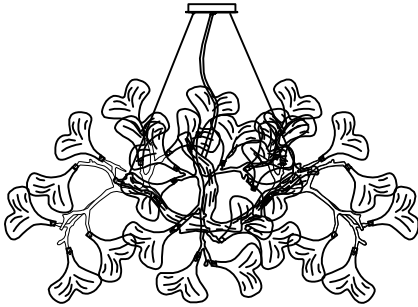

Tree branch adjustment diagram

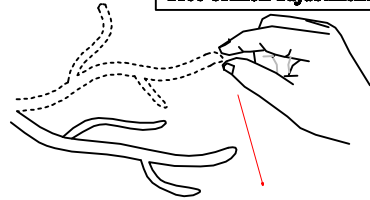

- Step.1: Swing the pole and lamp holder to achieve your desired effect.**
- Step.2: Hold the branch with your hands and spread it out evenly.**

- **Follow the steps above to adjust the effect as shown below (you can also adjust it the way you like)**

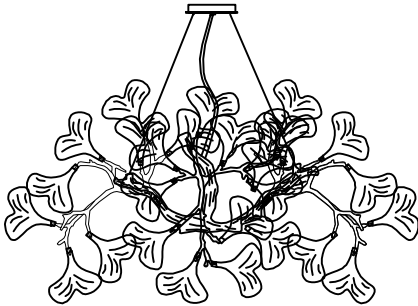

- ③ **Adjust the branches to a satisfactory shape, as shown below, and start the next step of fixing the hanging ornaments (as shown below)**

Hook in corresponding hole

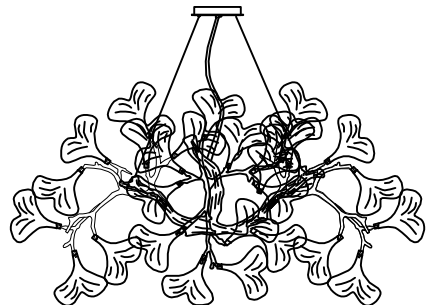
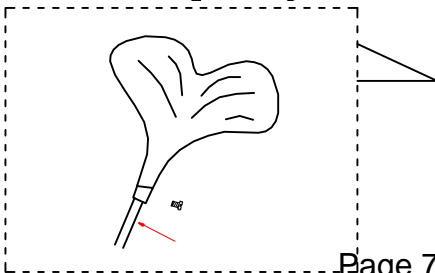

install effect A(angle ceiling)

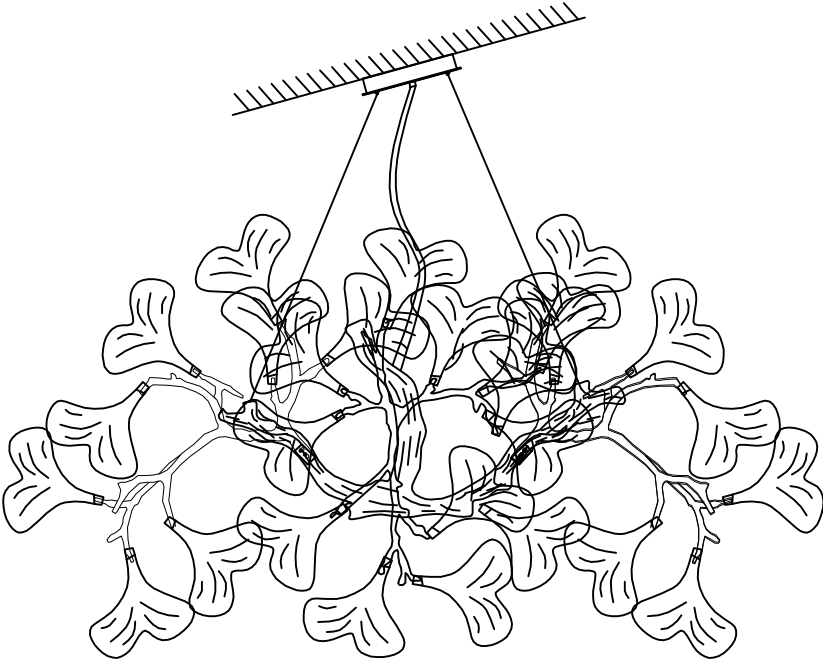

NOTES: Due to the handmade nature of the product, slight variations in dimensions may occur.

Cautions.

- 1.This lamp can only be used indoors;
- 2.TURN OFF THE POWER BEFORE THE INSTALLATION IS FINISHED.

install effect A(Flat ceiling)

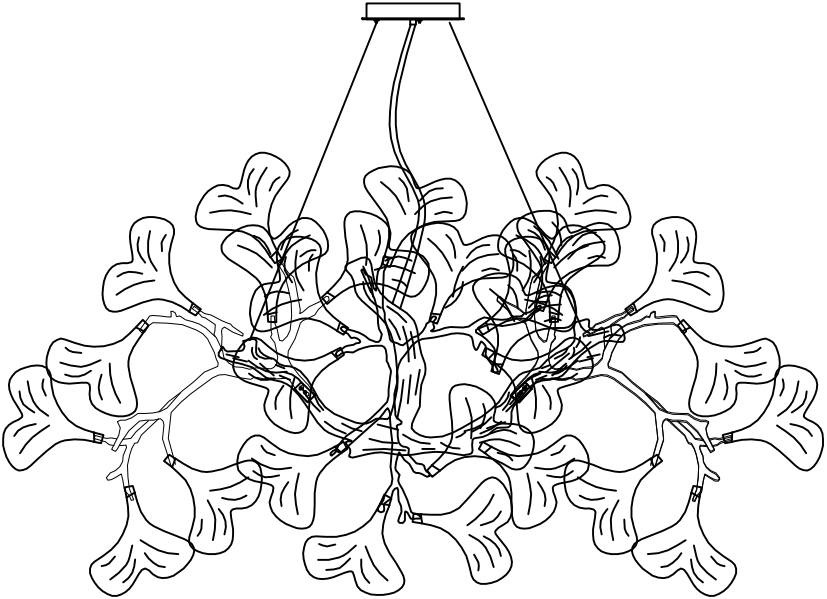

NOTES: Due to the handmade nature of the product, slight variations in dimensions may occur.

Maintenance:

To ensure safe and efficient use of this product, please clean the lamp regularly (once a month). Before cleaning, turn off the power and wait for the lamp to cool to room temperature. Then use a soft cloth dipped in water and wrung dry to wipe it clean.

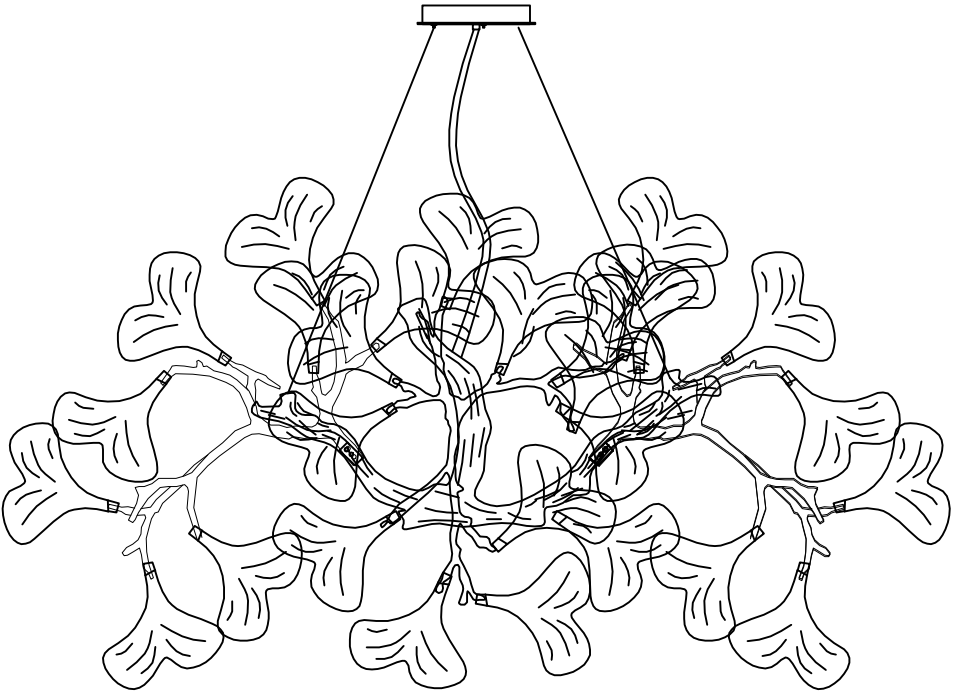

Please note:

Please check the parts list, if the parts are missing during your actual installation, please contact us, we will help you in time!

★ If your product has any issues upon receipt, please:

- 1. Provide your order number.**
- 2. Attach a photo or video of the issue.**
- 3. Contact us through the platform's customer service.**

Warranty

Our dedicated customer service team is available 24 hours a day to assist you. If you have any questions or concerns, we guarantee a response within 24 hours. During the warranty period, if you encounter any problems or need assistance, please don't hesitate to reach out to us via email. To ensure a swift and accurate resolution, kindly provide your order ID and detailed information regarding the issue.

Important Note: Please use this light fixture only for its intended purpose and avoid retrofitting or remodeling it. The warranty does not cover failures caused by third-party products or natural disasters.