

DATE STAMP

--

EB-3216

Base cabinet

2 Person Assembly Recommended

Il est recommandé de monter ce produit à 2 personnes

Dos personas son recomendadas para el ensamblaje del producto

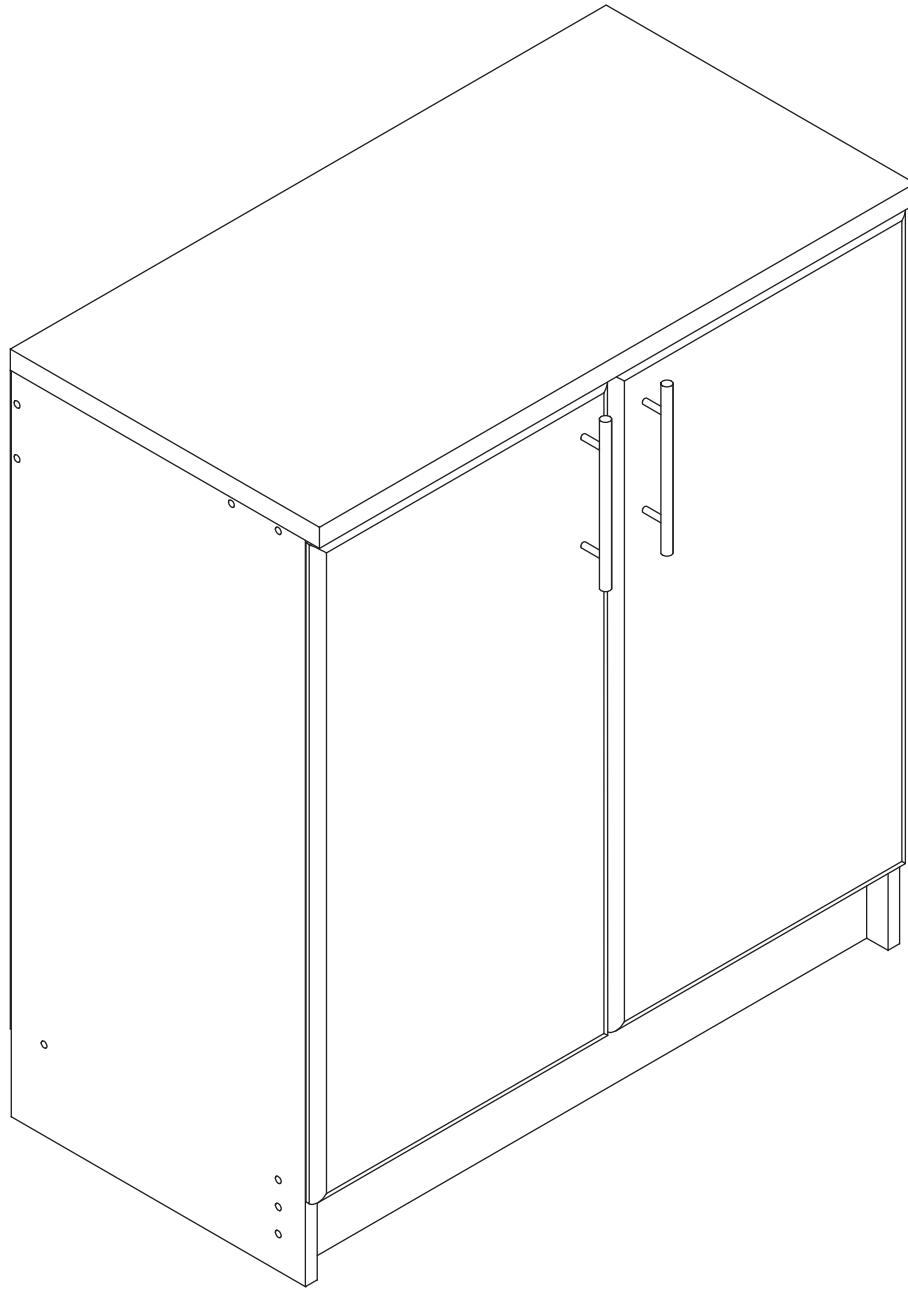

NEED ASSISTANCE CONTACT US FIRST!

**Website:**

www.prepacmfg.com/content/replacement-part-order

Complete our easy to use order form

**Email:**

parts@prepacmfg.com

**Phone:**

1-877-PREPAC1 (1-877-773-7221)

Mon-Fri: 7am-4pm PST / 10am-7pm EST

- If you have received a damaged or defective part
- If you are missing hardware or parts
- For help with assembly

Option de service en ligne

- Si vous avez reçu une pièce endommagée ou défectueuse
- Si vous manquez la quincaillerie ou les pièces

Complétez le formulaire Commande de Pièces de Rechange disponible dans la section Soutien à la clientèle de notre site web: www.prepacmfg.com

Ou envoyez un e-mail à parts@prepacmfg.com

Les pièces de rechange quitteront notre installation dans deux jours ouvrables via UPS par terre ou le courrier. Notez s'il vous plaît que les temps d'expédition varieront selon l'emplacement.

Pour parler avec quelqu'un en français, s'il vous plaît contacter votre détaillant.

Replacement parts will leave our facility within two business days via UPS ground or mail. Please note: shipping times will vary depending on location.

Before you call please:

- 1) Record the following information from the shipping label on the outside of the box. You will need it for warranty purposes:
 - Ship To Name
 - Sales Order Number
- 2) Note the product model number.
- 3) Review the contents of your shipment to determine what you are missing.

Opción de servicio en línea

- Si usted ha recibido una parte dañada o defectuosa, o
- Si falta alguna parte o componente

Complete la forma para solicitud de piezas de remplazo en la sección de soporte al cliente en nuestra página web www.prepacmfg.com

O envíenos sus preguntas al correo parts@prepacmfg.com

Para solicitar ayuda en español por favor contacte su distribuidor.

Las piezas de recambio dejarán nuestras instalaciones dentro de dos días hábiles vía UPS correo terrestre. Por favor note que el tiempo de transporte variara según la ubicación.

ONLINE HELP
L'AIDE EN LIGNE
AYUDA EN LINEA



To see how-to videos, go to the Product Support page on our website:
www.prepacmfg.com/content/assembly

Pour visionner les vidéo (en anglais) décrivant l'installation, consultez la page de "Product Support" sur notre site web : www.prepacmfg.com/content/assembly

Para ver videos de ayunda (en inglés), en nuestra pagina web click en las section "Product Support" www.prepacmfg.com/content/assembly

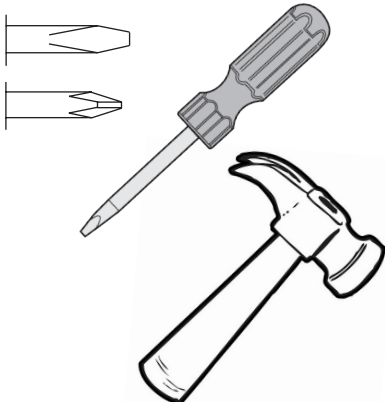
Required Tools**Outils requis****Herramientas necesarias****Optional Tools:**

Using a power screwdriver will speed up assembly.

CAUTION

Do not over tighten any screw. The last few turns of each screw should be done very slowly or by hand.

Outils facultatifs:

Utilisant la puissance un tournevis accélérera l'assemblée.

ATTENTION

Évitez de trop serrer les vis. Ralentissez la vitesse de la foreuse pour les derniers deux tours de vis ou vissez-les lentement à la main.

Herramientas opcionales:

El montaje será más rápido con un destornillador eléctrico.

PRECSUCION

No apriete los tornillos demasiado. Las últimas vueltas de cada tornillo deben hacerse muy lentamente o con la mano.



Part numbers are for reference only.
Product parts are not labeled.

Les numéros de pièce sont à titre de référence seulement.
Les pièces du produit ne sont pas étiquetées.

Los números de pieza son sólo de referencia.
Las piezas del producto no están etiquetadas.

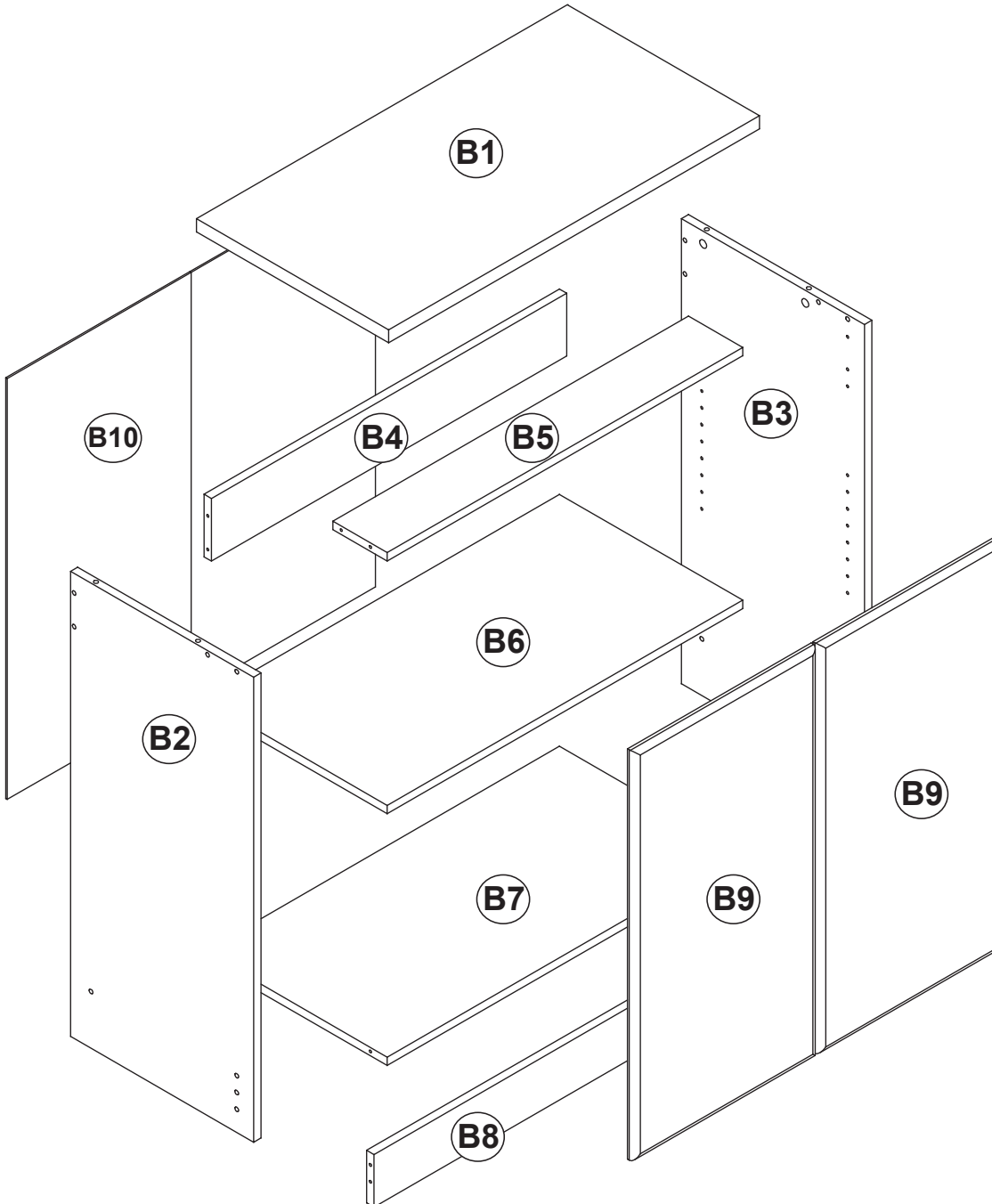

B1 TP-10182 light grey
or
TP-10183 dark grey

B2 SL-10175-W white
SL-10175-B black

B3 SR-10175-W white
SR-10175-B black

B4 ST-1034 white
ST-1134 black

B5 ST-1035 white
ST-1135 black

B6 SF-1008 white
SF-1108 black

B7 SH-1008 white
SH-1108 black

B8 KR-1008 white
KR-1108 black

B9 DR-1034 white
DR-1134 black

B10 BB-10148-W white
BB-10148-B black

RM-0103

X4



RM-0001

X16



RM-0501

X4

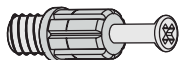

RM-0022

X20



RM-0802-W
or
RM-0802-B

X4

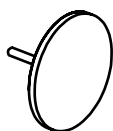

RM-0004

X8



RM-0008-W
or
RM-0008-B

X16



RM-0018

X4

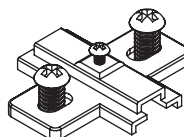

RM-0010-W
or
RM-0010-B

X4



RM-0125

X4

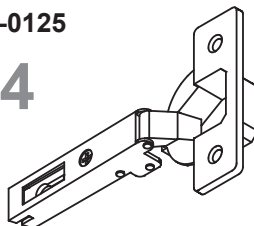

RM-0306-C

X2

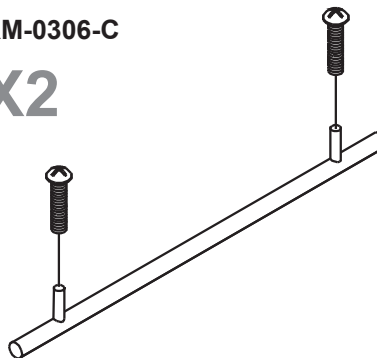

1

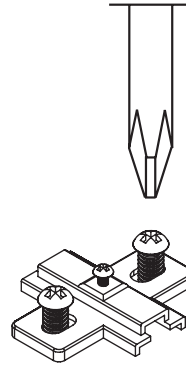
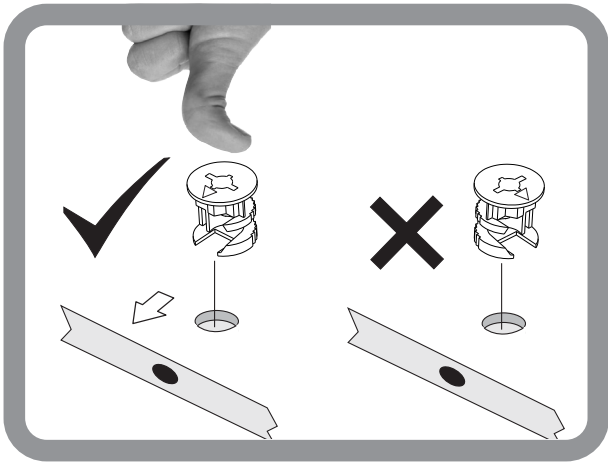

RM-0018
X4

RM-0103
X4

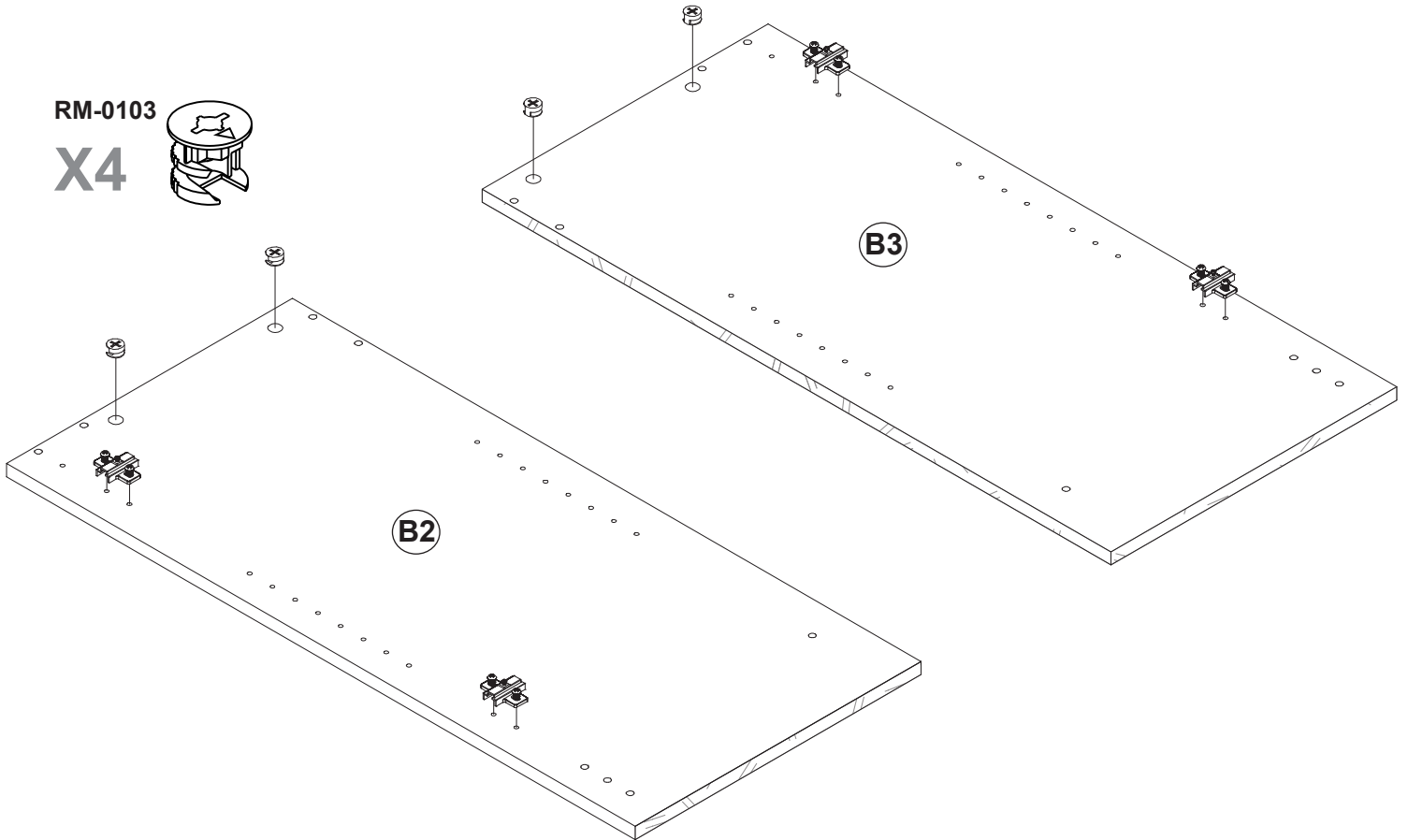

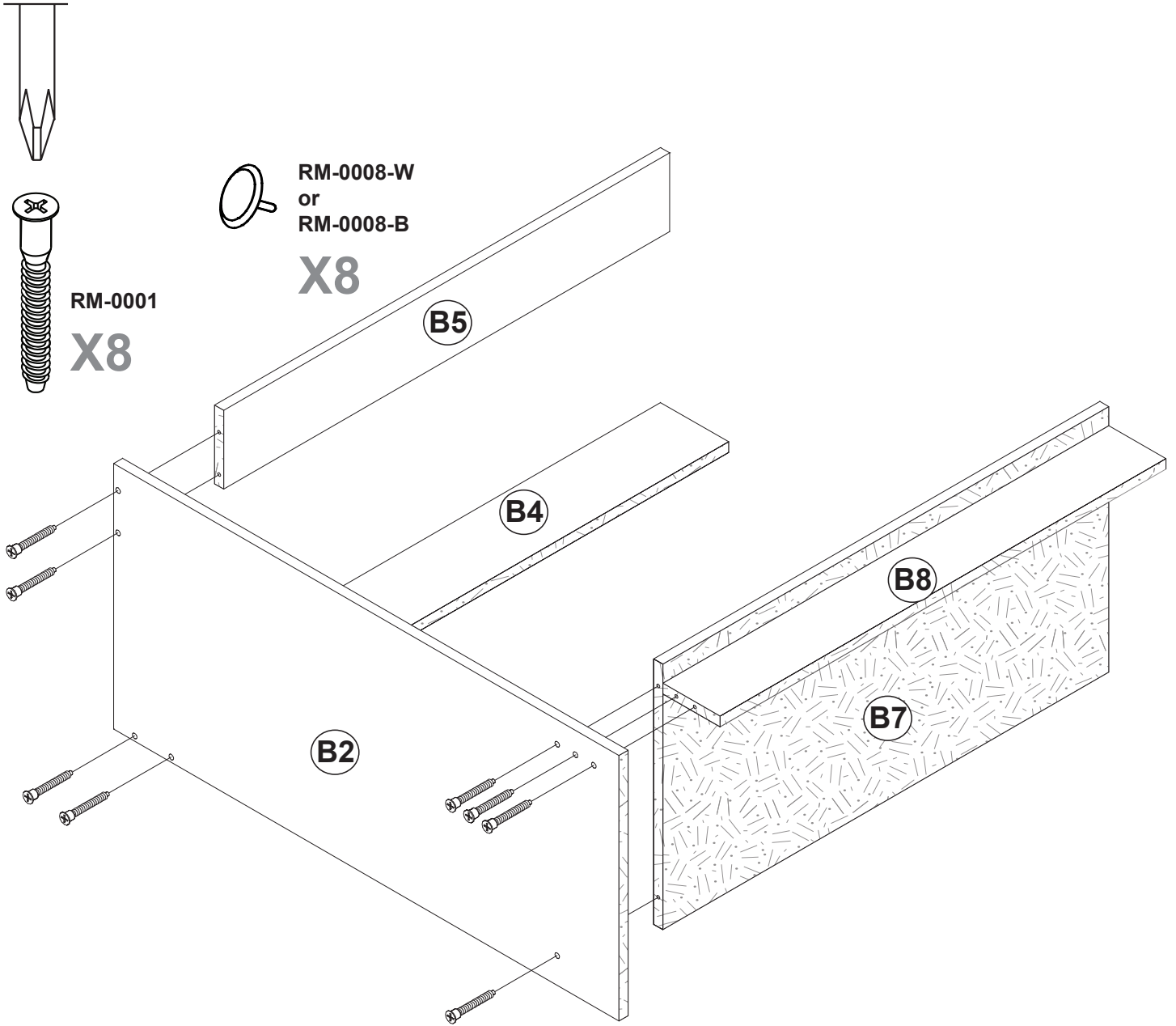

3

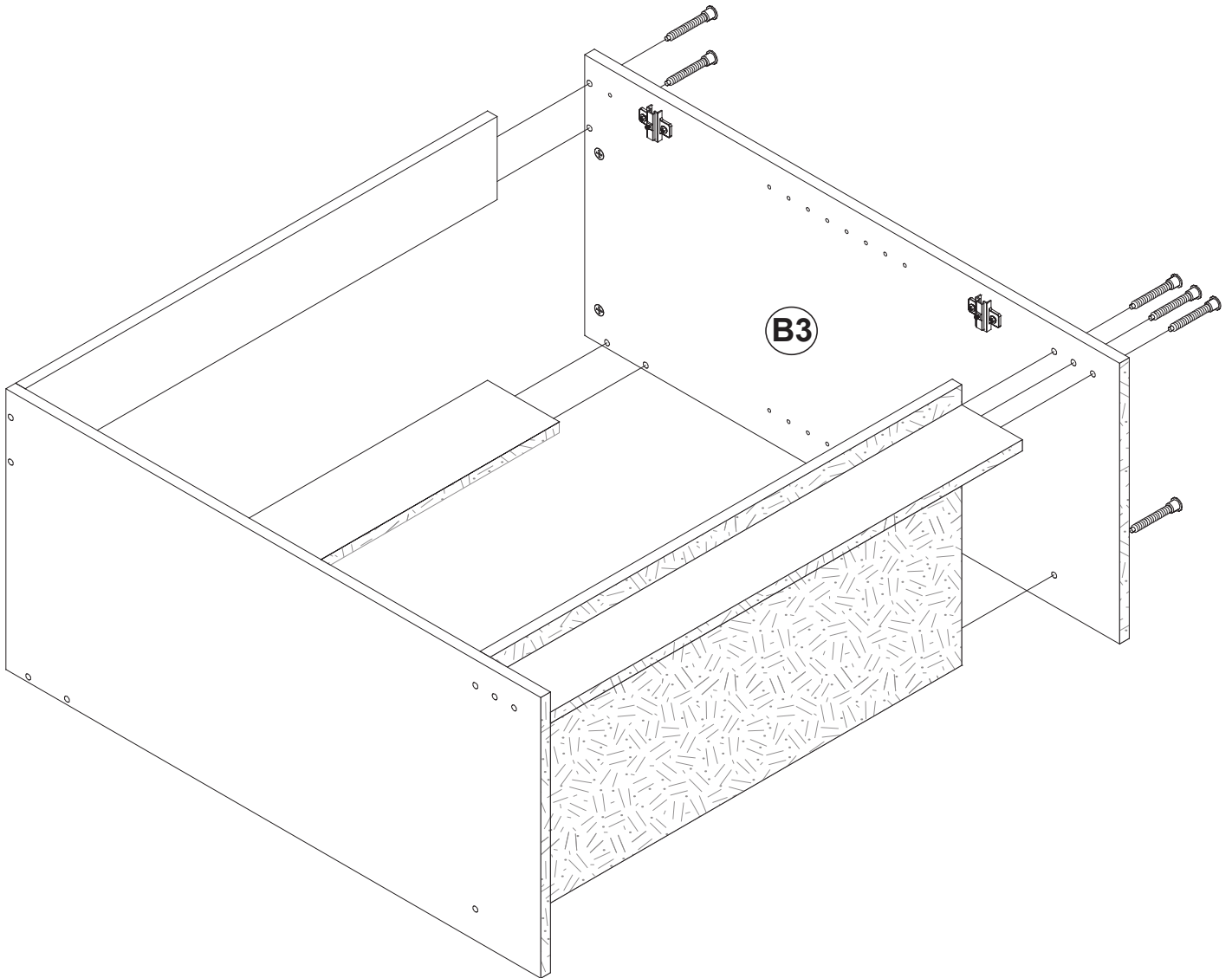

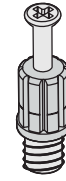

RM-0501

X4

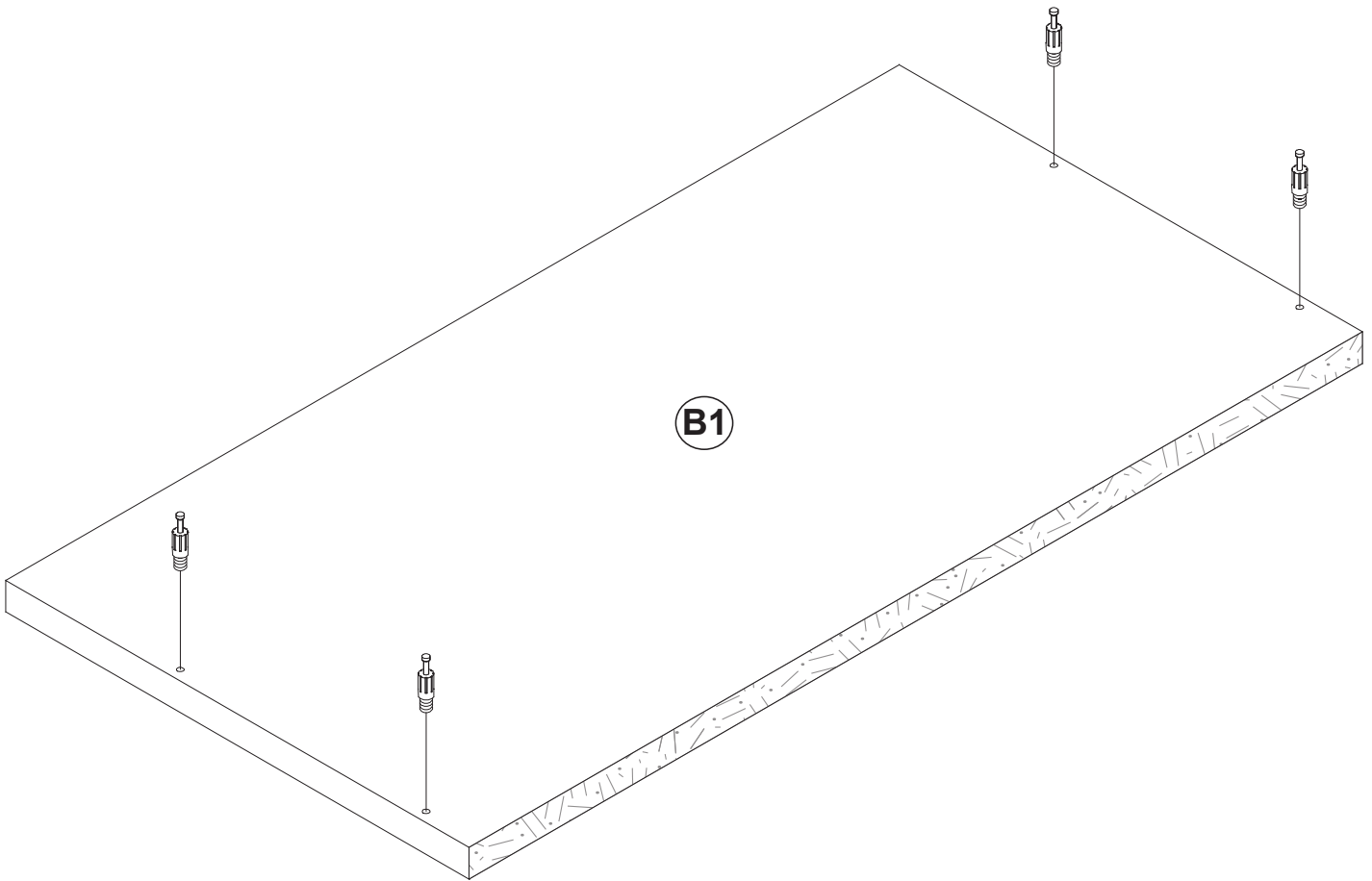

5

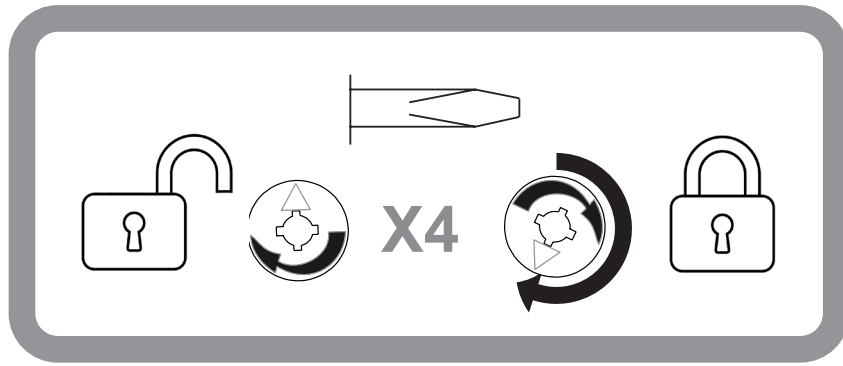

RM-0802-W
or
RM-0802-B
X4

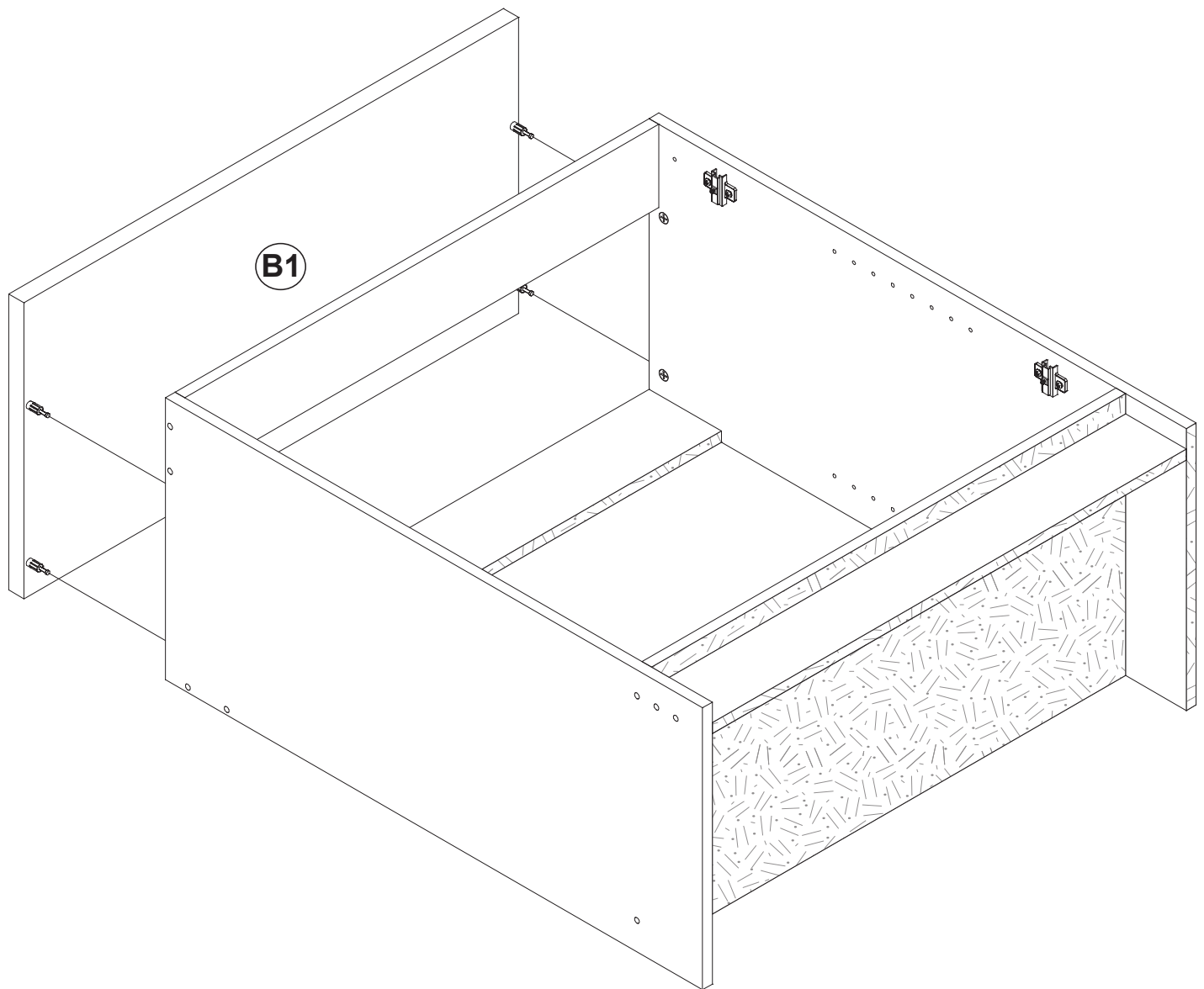
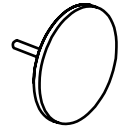

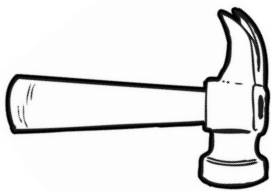

RM-0022

X20

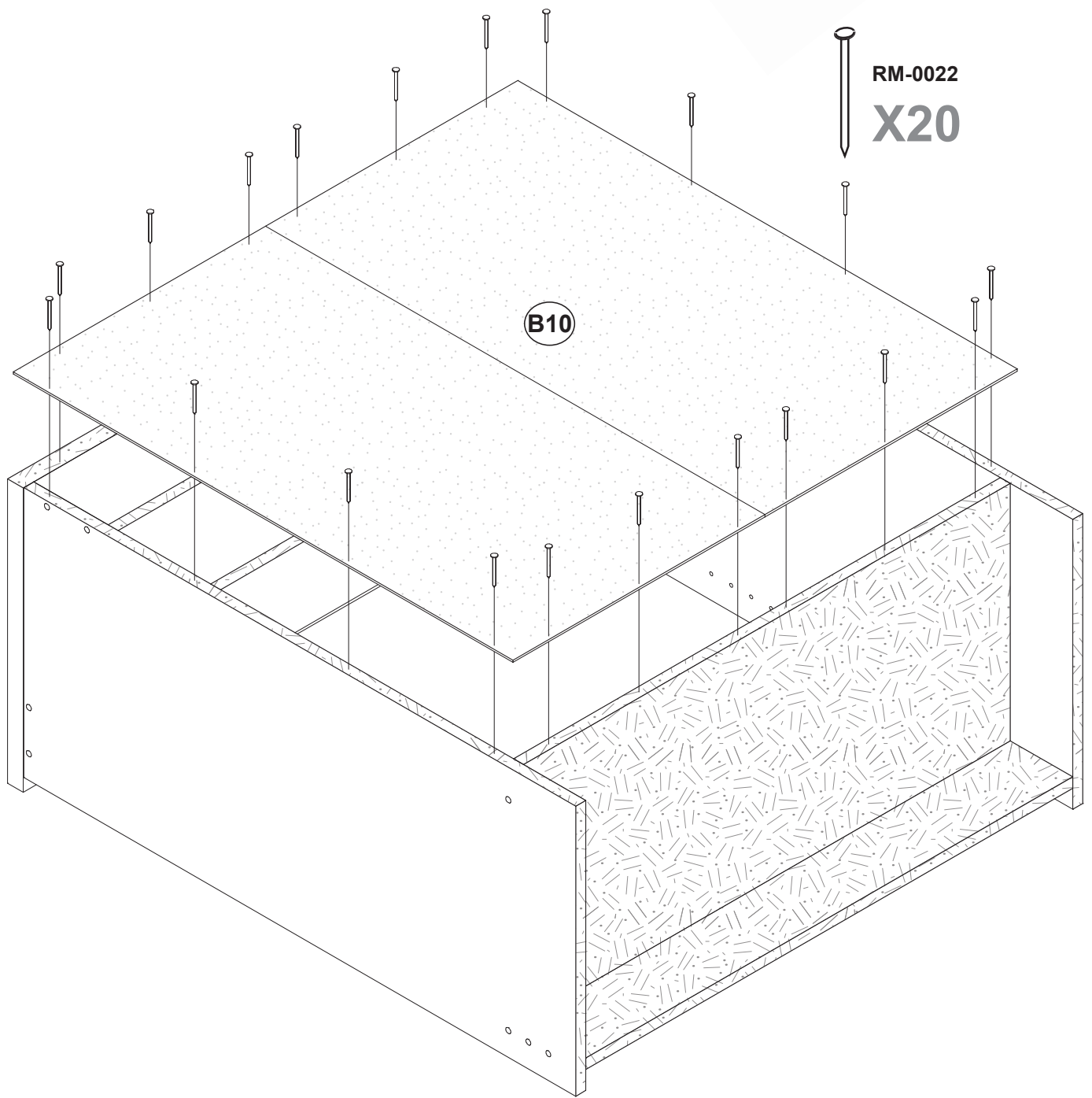

7

Each door has been template drilled on the back side in two locations so that it can be positioned to open either left or right.

Le dos des chaque portes comporte des trous percés selon un gabarit à deux endroits, de façon à pouvoir les installer selon une configuration d'ouverture à gauche ou à droite.

You will need to make one door "Left Opening" and one door "Right Opening"

Vous devrez installer une porte selon la configuration «d'ouverture à gauche» et l'autre selon la configuration «d'ouverture à droite».

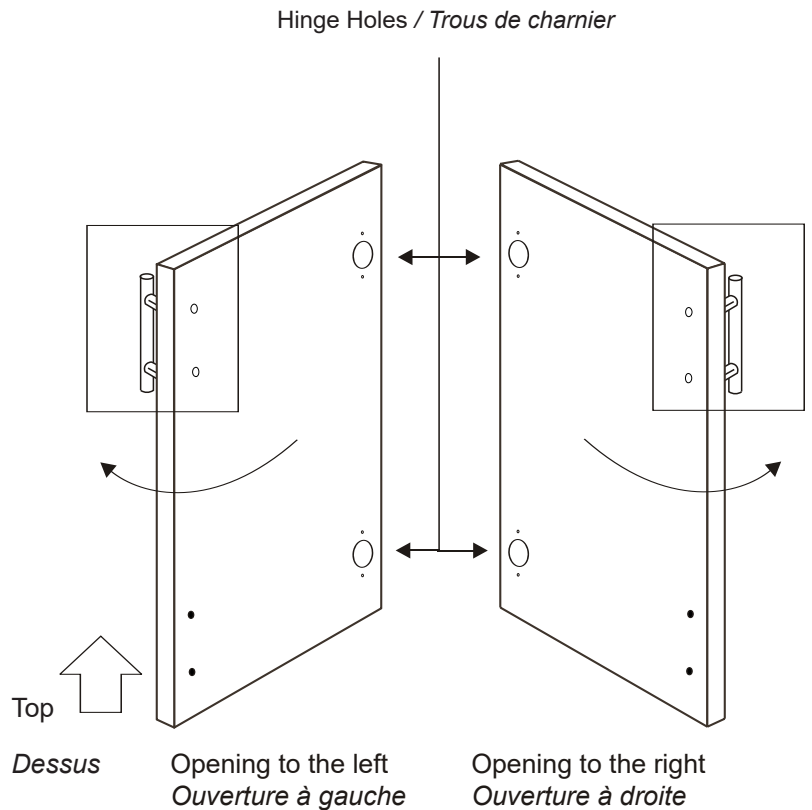

Drill through the holes at the desired location.

IMPORTANT: With a "C" clamp, secure a wood block or piece of scrap material behind the door. This will prevent the drill bit from chipping the front of the door when it penetrates through the door.

REMEMBER:
Check twice
Drill once

Percer les trous à l'emplacement désiré.

IMPORTANT : à l'aide d'une bride en C, fixer une pièce de bois ou de métal au dos de la porte afin d'éviter les ébréchures à la surface au moment où la mèche passe au travers de la porte.

AIDE-MÉMOIRE :
Vérifier à deux reprises
Percer une seule fois

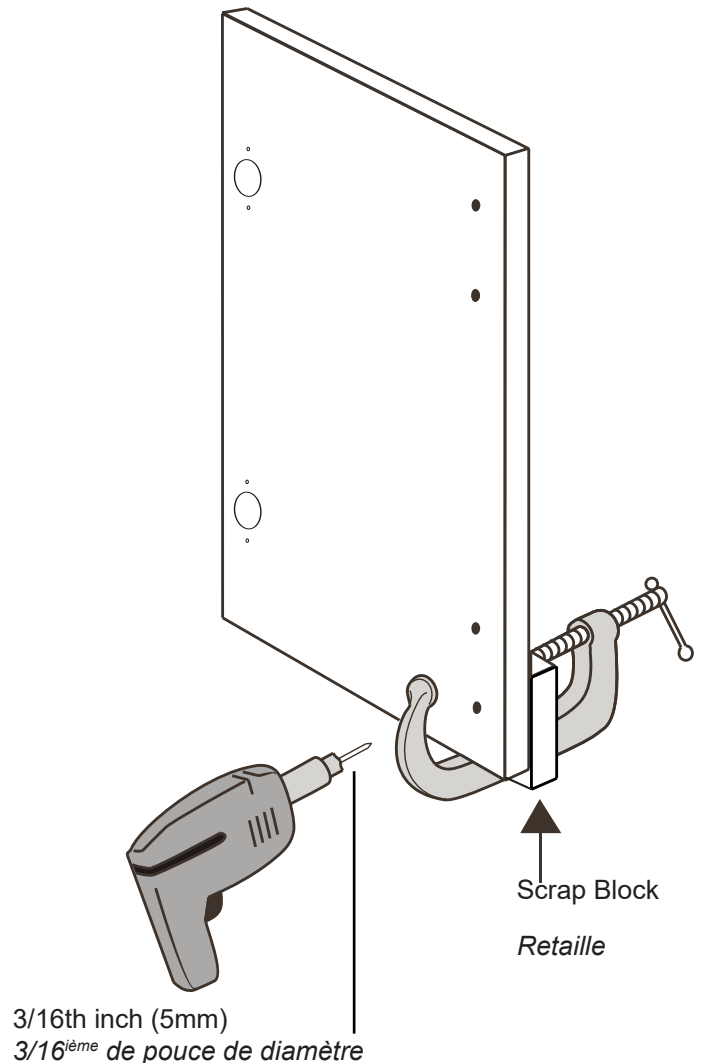



RM-0004

X8

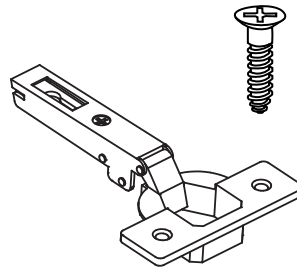

RM-0125

X4

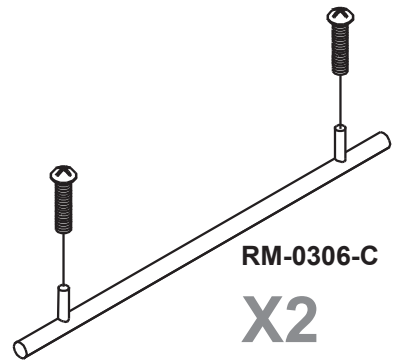
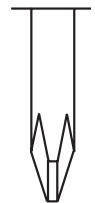
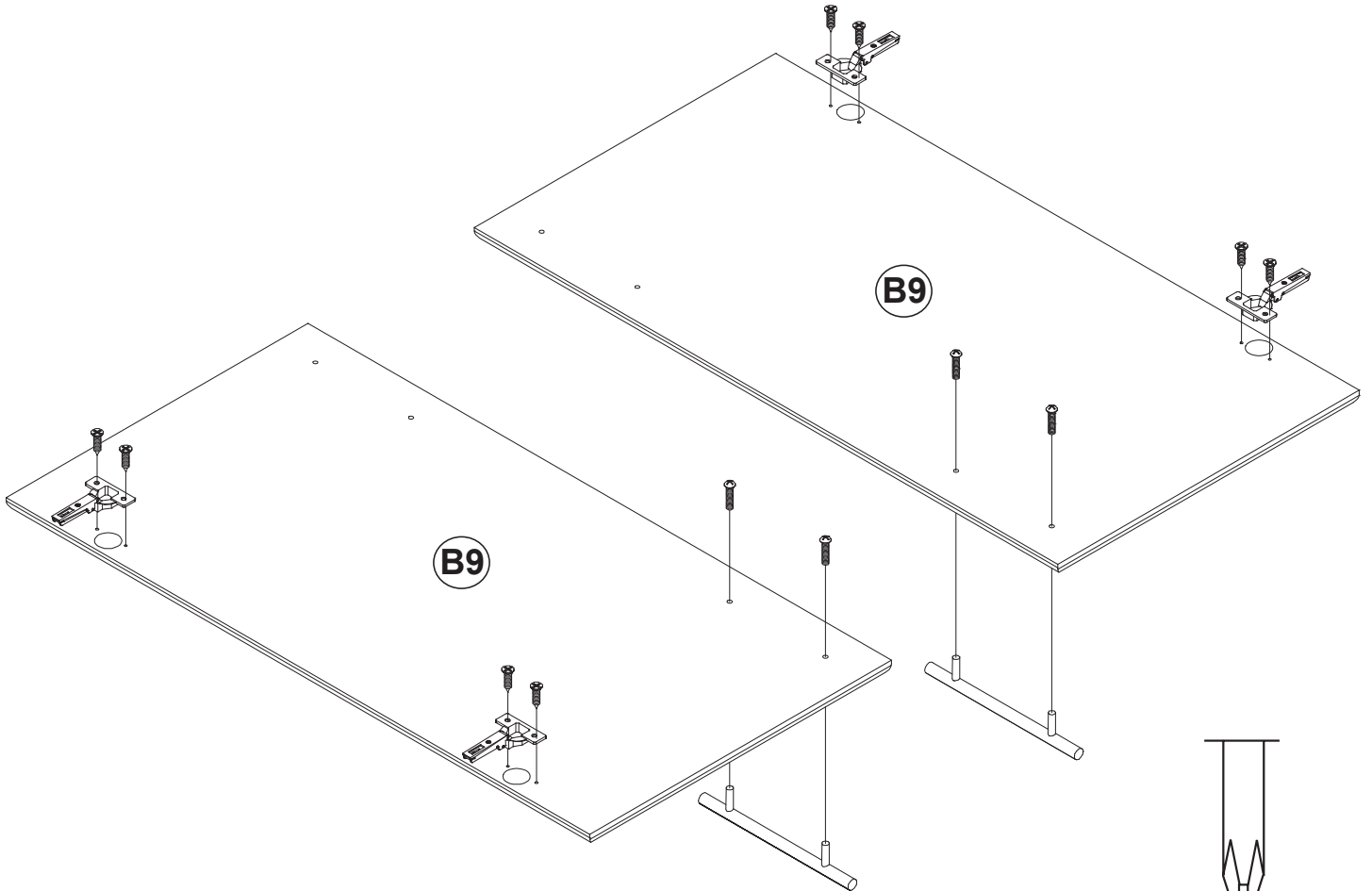



RM-0306-C

X2

9

RM-0010-W
or
RM-0010-B

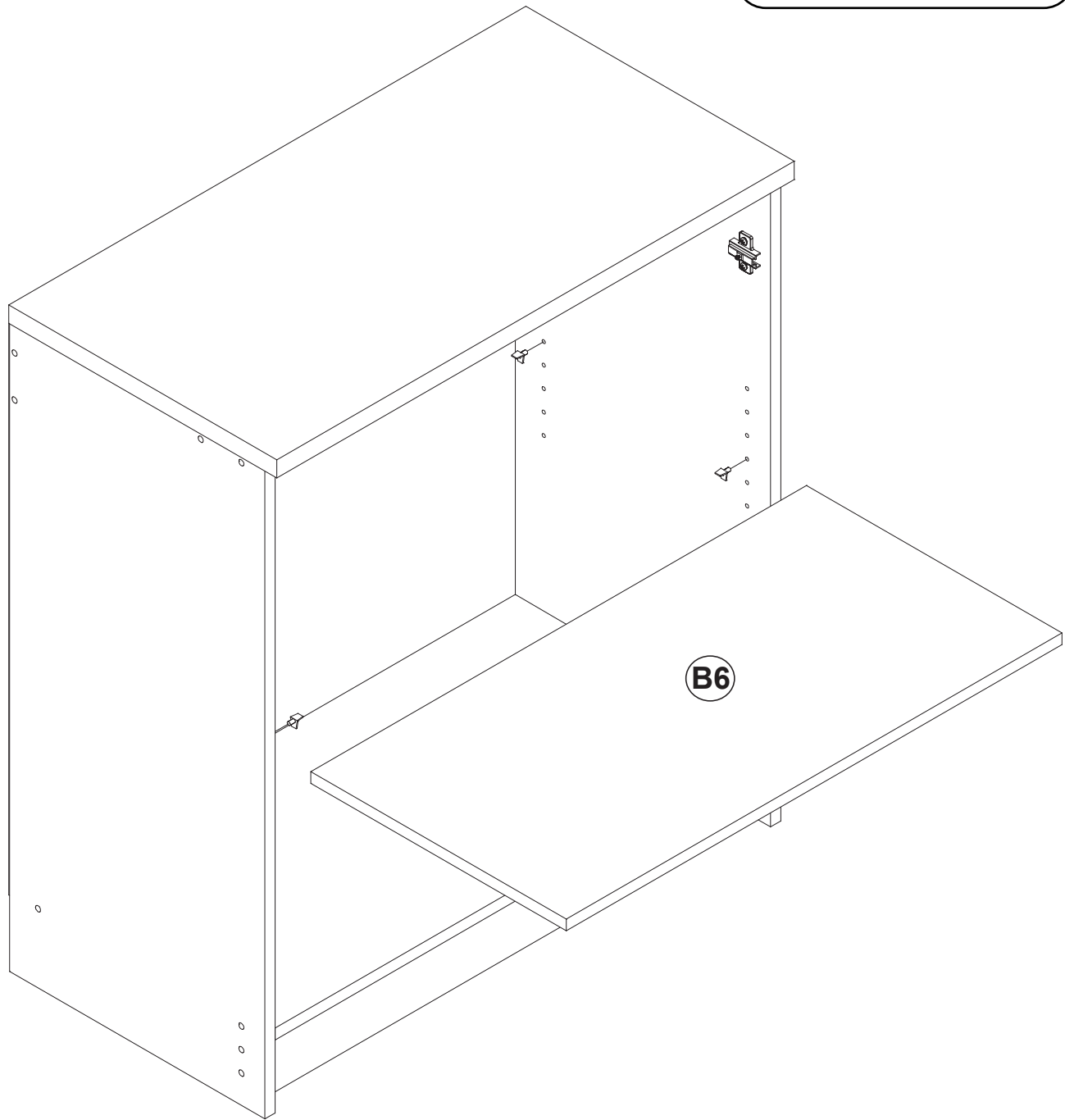
X4



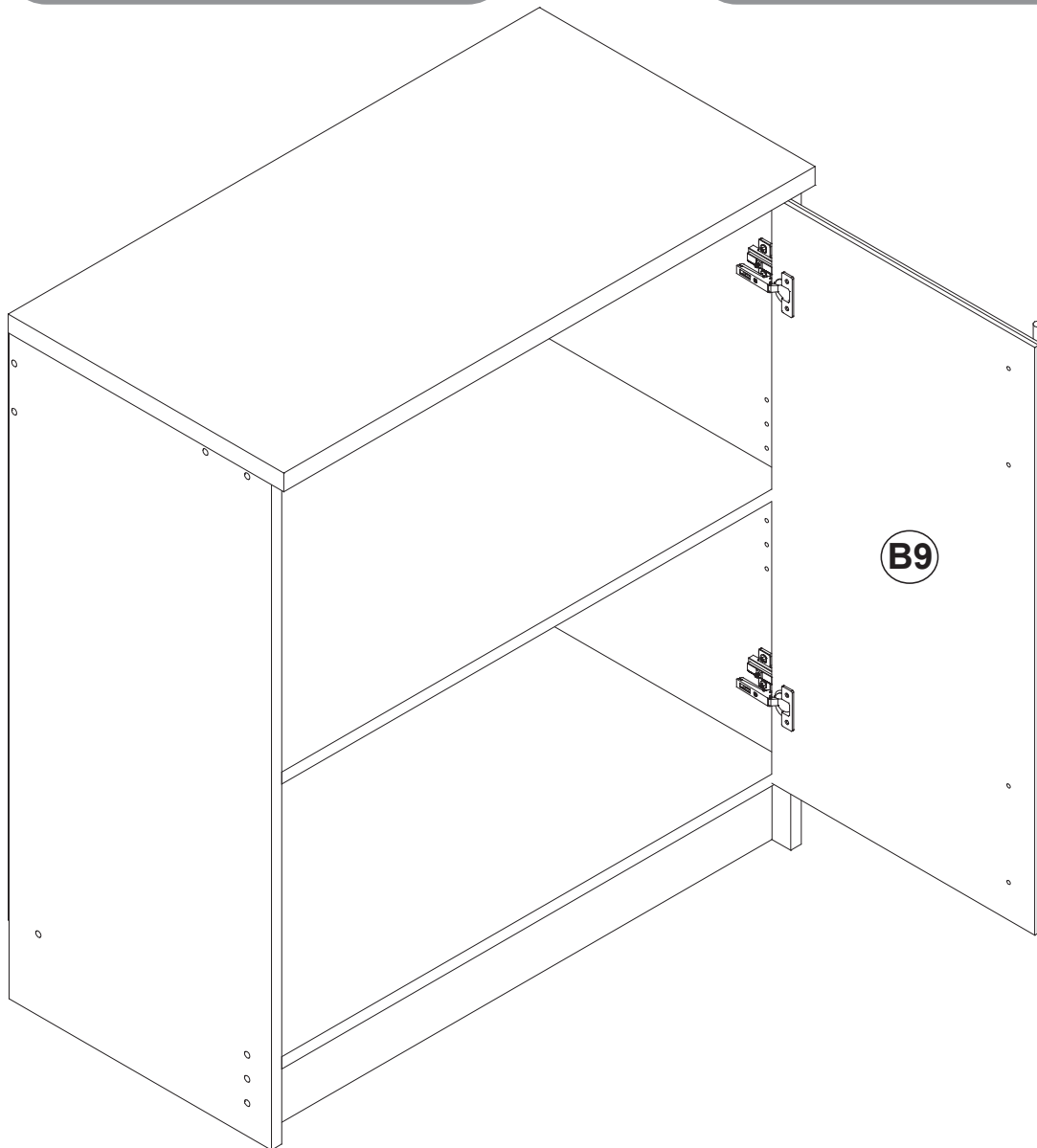
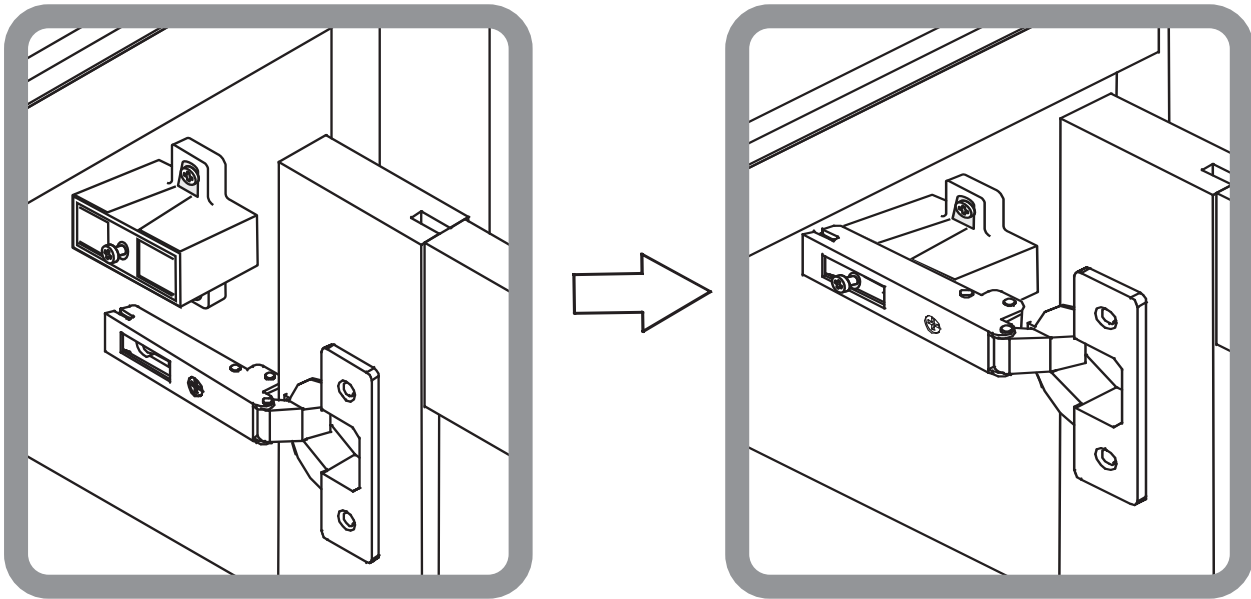

Scan for
Hinge Adjustment
Instruction Video

Rechercher Vidéo d'instructions
de réglage des charnières



Hinge Adjustments

Hinges are 6-way adjustable, allowing you to make precise adjustments.

Vertical Door Alignment:

Loosen the top & bottom Hinge Plate Screws (on both hinge sets) and move the door up or down.

Alignement de la porte verticale:

Desserrez le haut & bas plaque charnière vis (sur les deux charnières) et déplacer la porte vers le haut ou vers le bas.

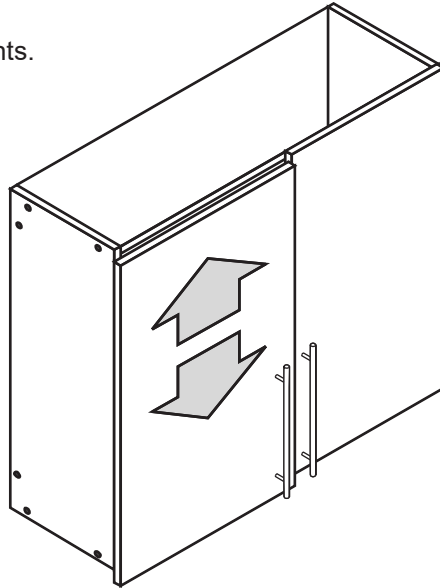

Adjust the space between the door and cabinet

Loosen the Fixing Screw and slide the door toward or away from the cabinet. Then, tighten the Fixing Screw.

Ajuster l'espace entre la porte et cabinet

Desserrez la vis de fixation et faites glisser la porte vers ou loin du cabinet. Ensuite, serrez les vis de fixation.

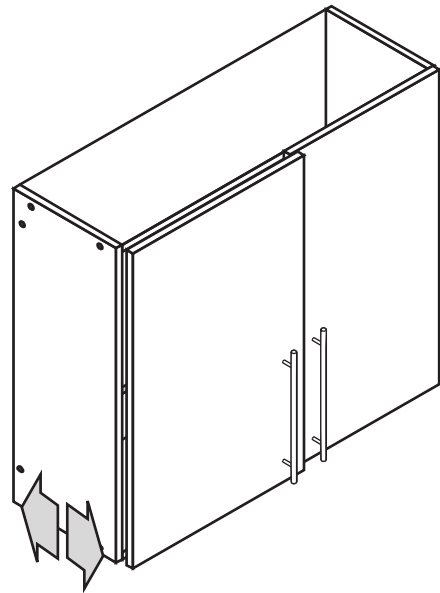

Adjust the space between the doors

- First, loosen the Fixing Screw
- To move the doors closer together, tighten the Adjustment Screw
- To move the doors farther apart, loosen the Adjustment Screw

Ajuster l'espace entre les portes

- D'abord, desserrez la vis de fixation
- Pour déplacer les portes plus étroite comprenant, serrez la vis de réglage
- Pour déplacer les portes plus loin à l'écart, desserrez la vis de réglage

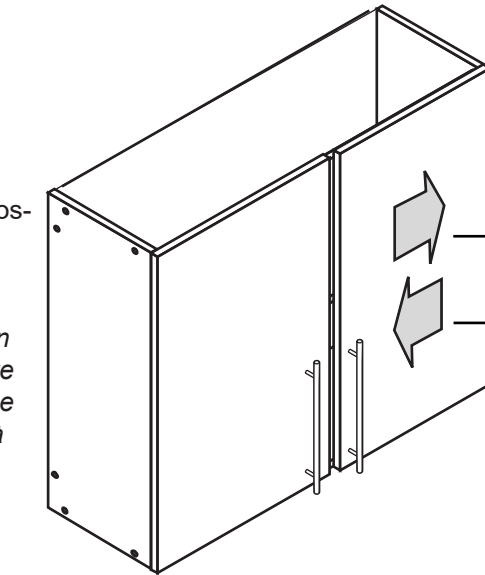

Ajustements de charnière

Les charnières sont 6-voies réglables, vous permettant d'effectuer des réglages précis.

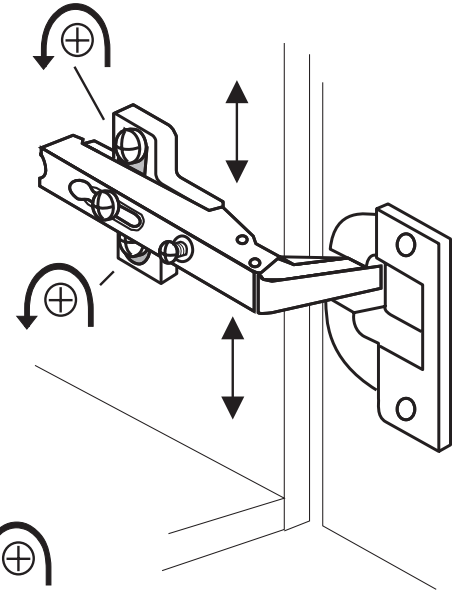

Fixing Screw
La vis de fixation

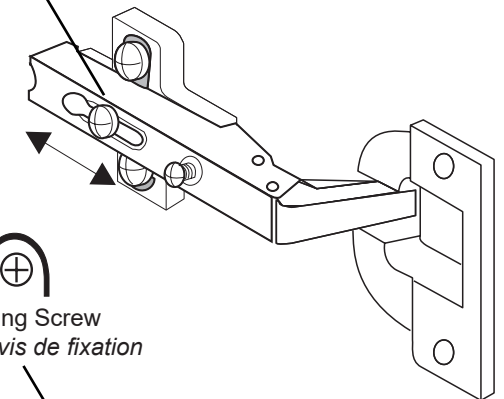

Fixing Screw
La vis de fixation

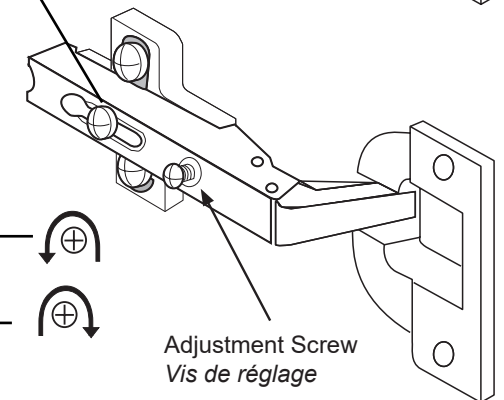

Adjustment Screw
Vis de réglage

Scan the QR code for Hinge Adjustment Instruction Video

Scannez le code QR pour la vidéo d'instructions de réglage des charnières

ONLINE HELP

To see a how-to video, go to the Product Support page on our website:

[www.prepacmfg.com/content/assembly/How to Adjust Hinges](http://www.prepacmfg.com/content/assembly/How%20to%20Adjust%20Hinges)

L'AIDE EN LIGNE

Pour visionner un vidéo (en anglais) décrivant l'installation, consultez la page de "Product Support" sur notre site web :

[www.prepacmfg.com/content/assembly/How to Adjust Hinges](http://www.prepacmfg.com/content/assembly/How%20to%20Adjust%20Hinges)



Sample Configurations



Laundry Room with 3 Door Wall Cabinet (WEW-5424)

Salle de lavage avec armoire murale à 3 portes (WEW-5424)



Laundry Room Installation with Wall Cabinets attached directly to the wall above Base Cabinets

Cette installation pour salle de lavage présente des armoires murales fixées directement au mur au-dessus des armoires sur plancher.



Garage Installation showing Wall Cabinets both as Toppers and attached directly to the wall

Cette installation pour garage présente des armoires murales installées en hauteur et fixées directement au mur.

Available Cabinets / Armoires disponibles



16" Stackable Wall Cabinet

Armoire murale

empilable 16 po
WEW-1624 (White / Blanc)
BEW-1624 (Black / Noir)
16"w x 24"h x 16"d



32" Stackable Wall Cabinet
Armoire murale empilable 32 po
WEW-3224 (White / Blanc)
EEW-3224 (Espresso)
BEW-3224 (Black / Noir)
32"w x 24"h x 16"d



54" Wall Cabinet
Armoire murale 54 po
WEW-5424 (White / Blanc)
BEW-5424 (Black / Noir)
54"w x 24"h x 12"d



32" w x 30" h Wall Cabinet
Armoire murale 32 po x 30 po
WEW-3230 (White / Blanc)
BEW-3230 (Black / Noir)
32" w x 24" h x 16" d



16" Broom Cabinet

Armoire à balai 16 po
WEB-1664 (White / Blanc)
BEB-1664 (Black / Noir)
16"w x 65"h x 16"d



32" Storage Cabinet

Armoire de rangement 32 po
WES-3264 (White / Blanc)
EES-3264 (Espresso)
BES-3264 (Black / Noir)
32" w x 65" h x 16" d



32" Wardrobe Cabinet

Penderie 32 po
WEW-3264 (White / Blanc)
BEB-3236 (Black / Noir)
32" w x 65" h x 20" d



32" Base Cabinet
Armoire sur plancher 32 po
WEB-3236 (White / Blanc)
BEB-3236 (Black / Noir)
32" w x 36" h x 24" d



16" Base Cabinet

Armoire sur plancher 16 po
WED-1636 (White / Blanc)
BED-1636 (Black / Noir)
16" w x 36" h x 24" d