

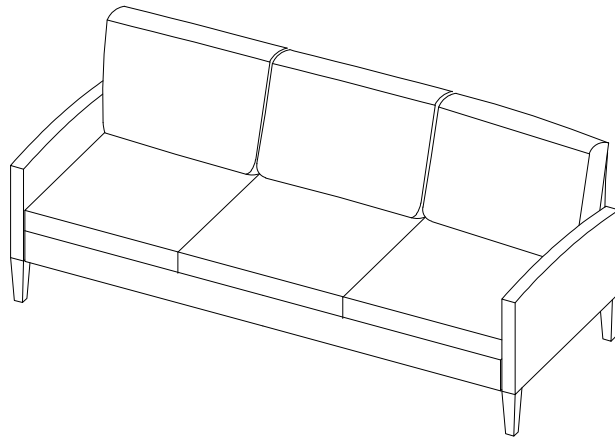

Outdoor Wicker Sofa

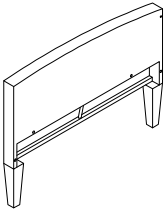
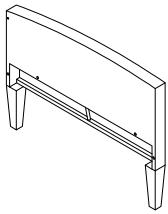
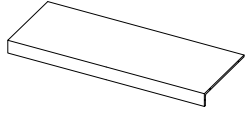
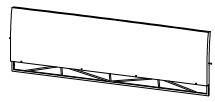
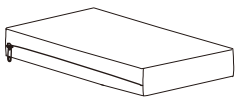
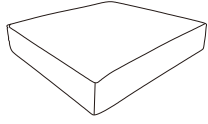

PART LIST

<p>A</p> 	<p>B</p> 	<p>C</p> 	<p>D</p> 	<p>E</p> 
<p>Right Arm Panel 1 PC</p>	<p>Left Arm Panel 1 PC</p>	<p>Seat Panel 1 PC</p>	<p>Back Panel 1 PC</p>	<p>Back Cushion 3 PCS</p>
<p>F</p>  <p>Seat Cushion 3 PCS</p>				

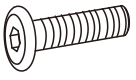
HARDWARE LIST

<p>#1</p>  <p>M6*35mm</p>	<p>#2</p>  <p>M6mm</p>	<p>#3</p>  <p>M6mm</p>
<p>Bolt 12 PCS (Extra 2)</p>	<p>Flat Washer 12 PCS (Extra 2)</p>	<p>Allen Wrench 1 PC</p>

Step 1. Lay right arm panel (part A) upside down on a soft flat surface, such as carpet, as shown below. Attach seat panel (part C) to right arm panel (part A) using bolts (part #1), flat washers (part #2) and allen wrench (part #3).

NOTE: Please do not fully tighten bolts until unit is fully assembled.

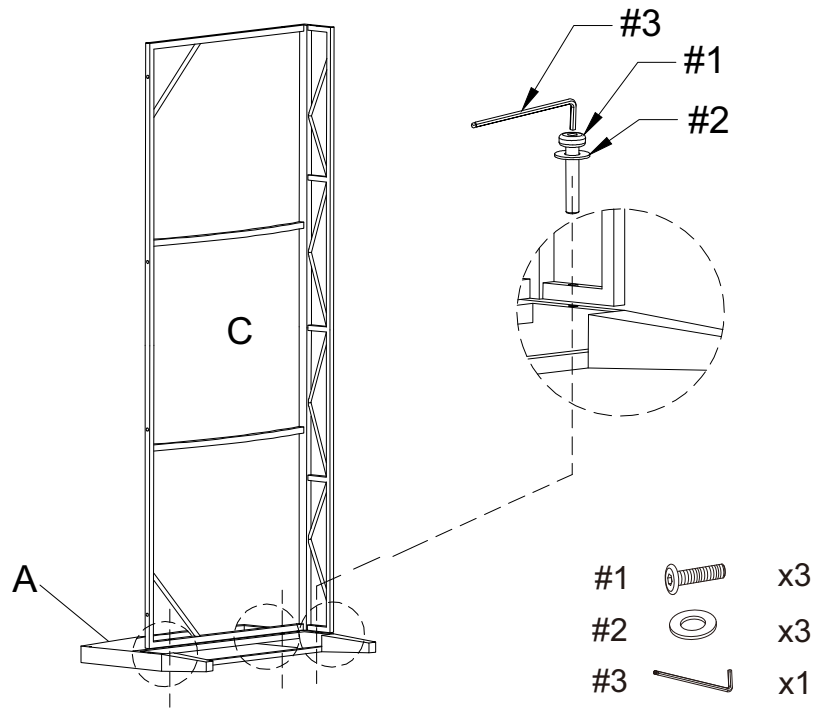

Step 2. Attach back panel (part D) to right arm panel (part A) and seat panel (part C) using bolts (part #1), flat washers (part #2) and allen wrench (part #3).

NOTE: Please do not fully tighten bolts until unit is fully assembled.

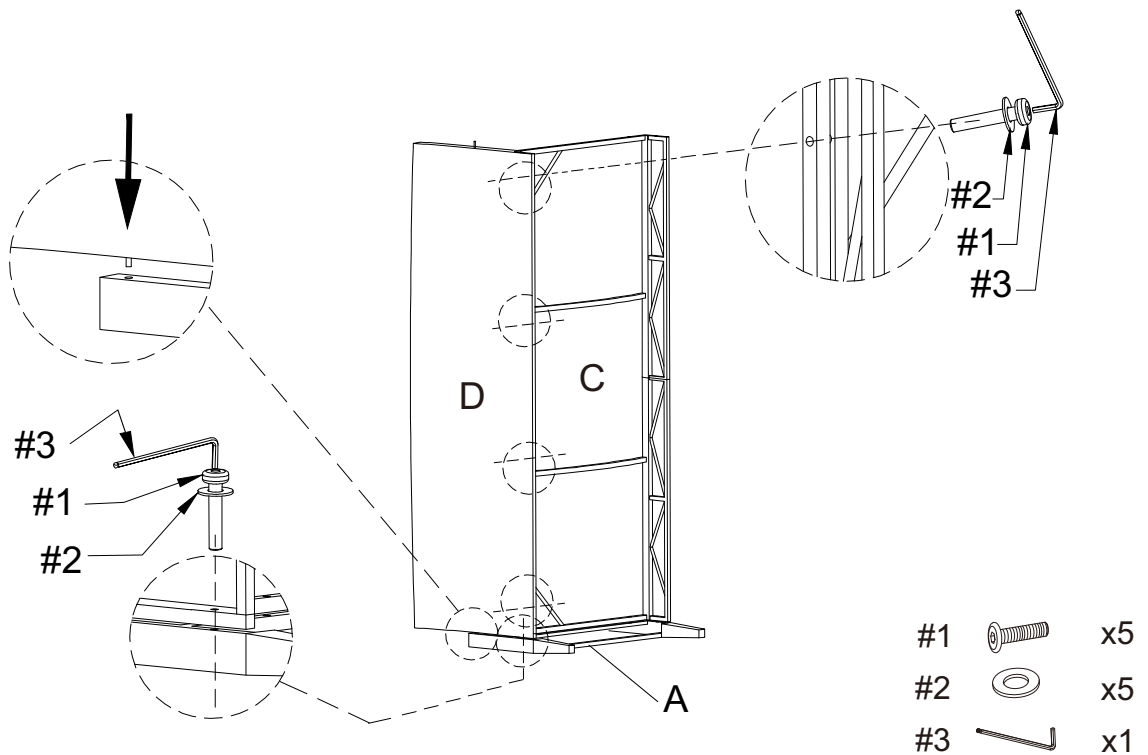

Step 3. Attach left arm panel (part B) to back panel (part D) and seat panel (part C) using bolts (part #1), flat washers (part #2) and allen wrench (part #3).

NOTE: Please fully tighten all bolts at this time.

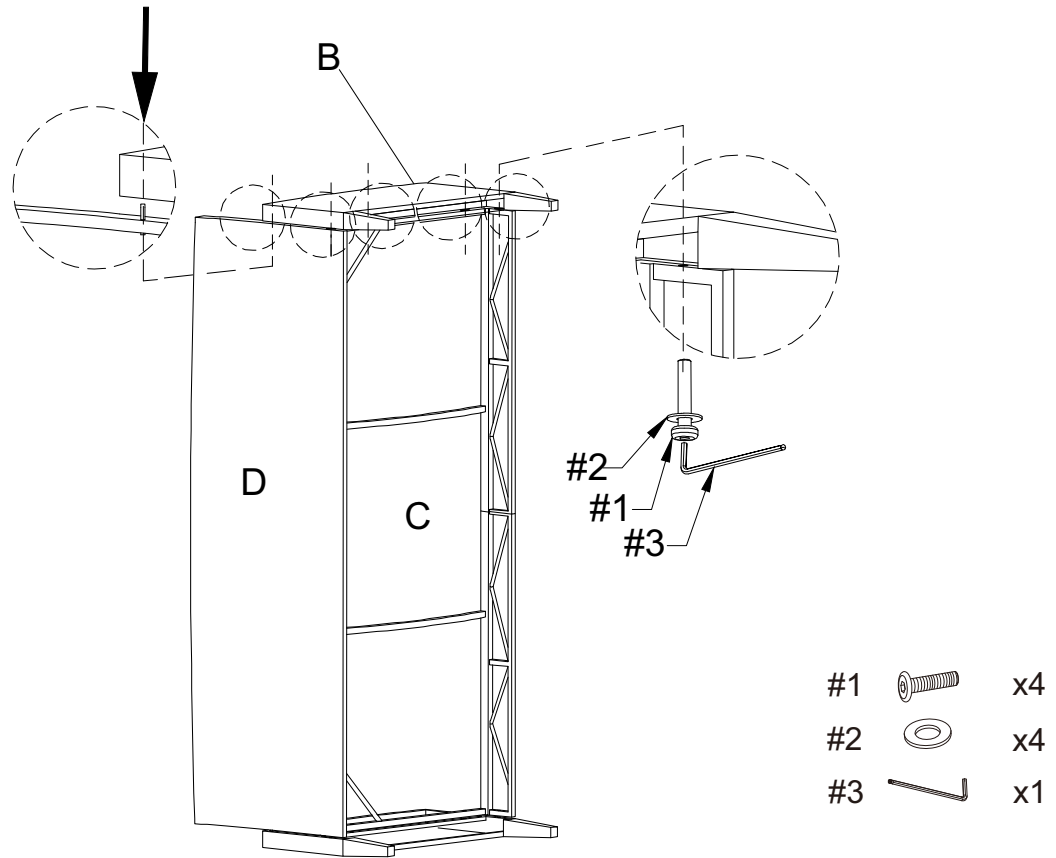

Step 4. Carefully turn unit upright. Add seat cushions (part F) and back cushions (part E) as shown below.

