

Owner Manual

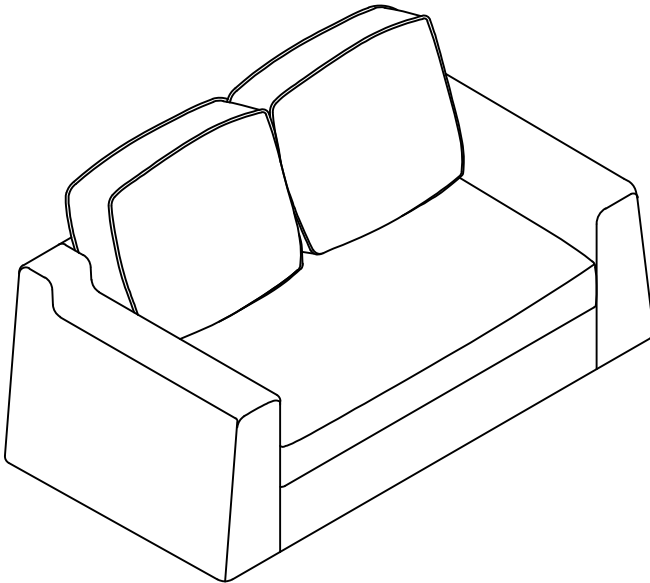

NOTE:

This brochure contains IMPORTANT safety info. Please read and keep for future reference.

MAINTENANCE AND WARNING

- 1.Keep furniture away from heat sources.
- 2.Do not clean furniture with harsh cleaner or polishes.Do not use detergents,solvents,abrasives,spray packs or leather cleaner. Use non-color mild soap with warm water to clean spills(Mix 1:10 soap to water).
- 3.Do not place furniture under direct sunlight,material will possibly fade over time.
- 4.Do not use on site dry cleaning machine.Children should not climb or jump on the furniture.
- 5.Do not write on furniture that is not protected by a padded barrier.
- 6.Not for commercial use,only for residential use.



Weight Limitation
600 LBS

PARTS LIST

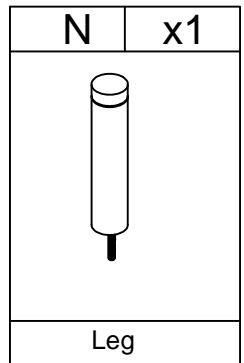
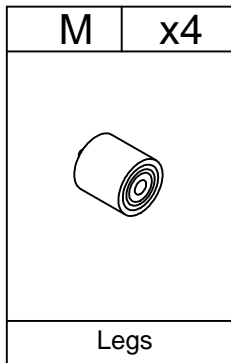
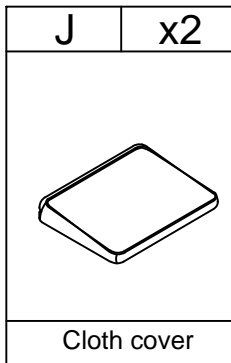
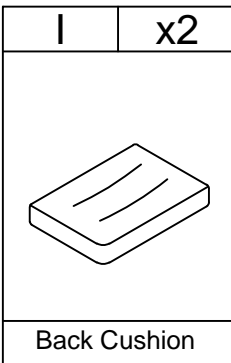
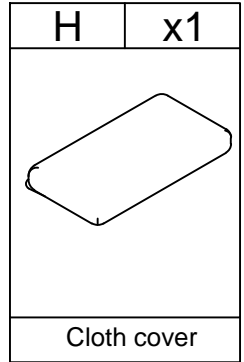
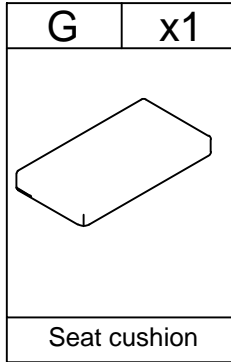
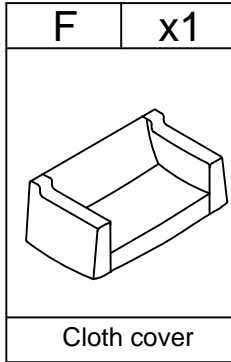
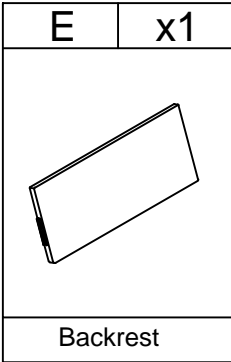
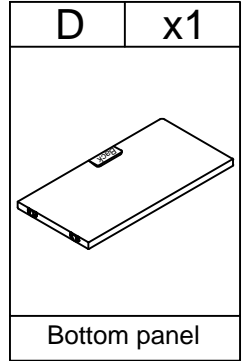
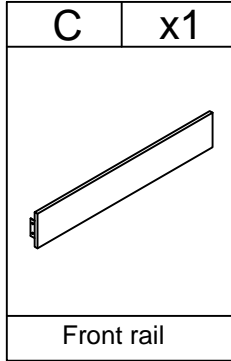
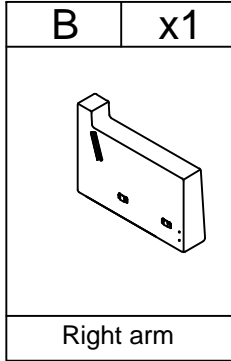
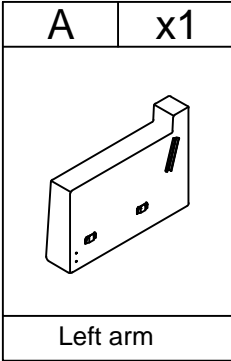

HARDWARE LIST

#1	x4
	
$\phi 5/16'' \times 23\text{mm}$	

TOOL LIST

#2	x1
	
M5	

HARDWARE SPARE LIST

#1	x1
	
$\phi 5/16'' \times 23\text{mm}$	

ASSEMBLY INSTRUCTIONS

STEP-1

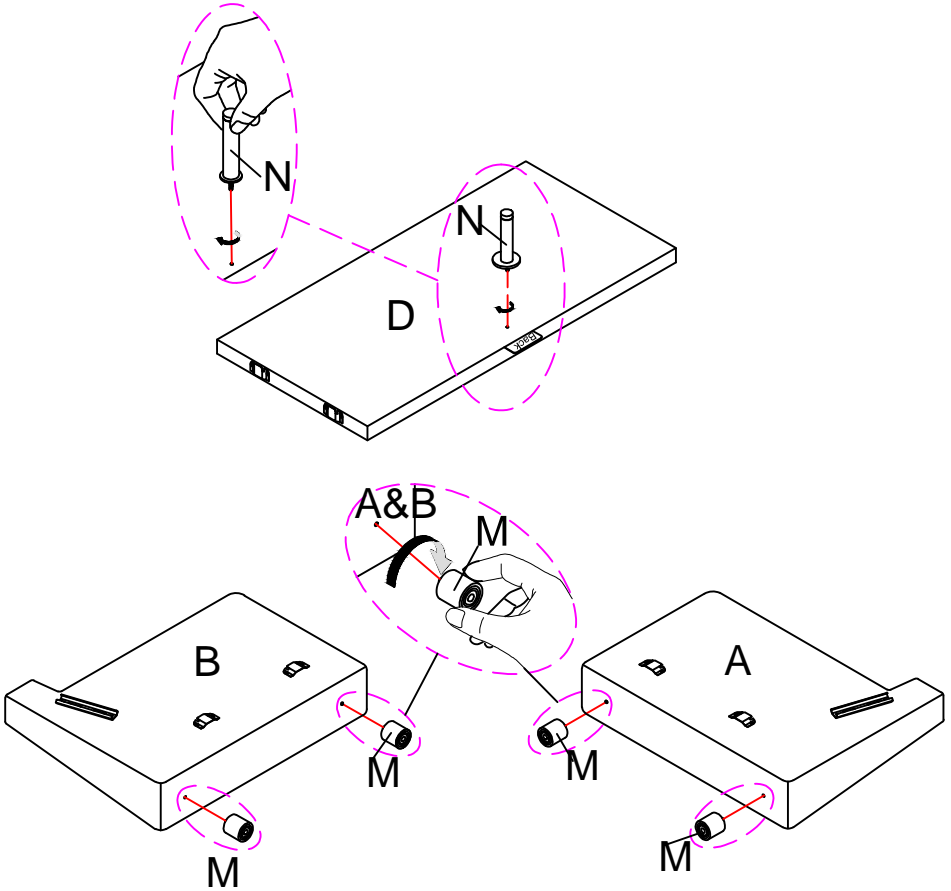

ASSEMBLY INSTRUCTIONS

STEP-2

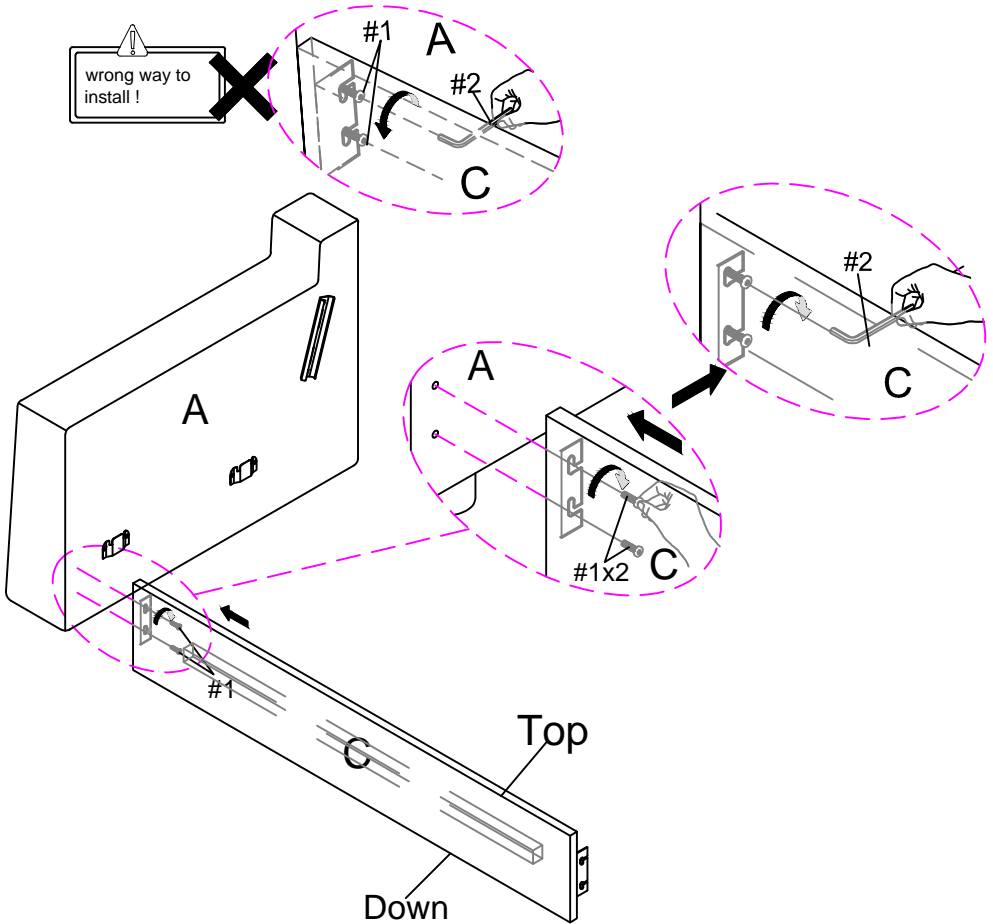



#2	x1
	
M5	

#1	x2
	

ASSEMBLY INSTRUCTIONS

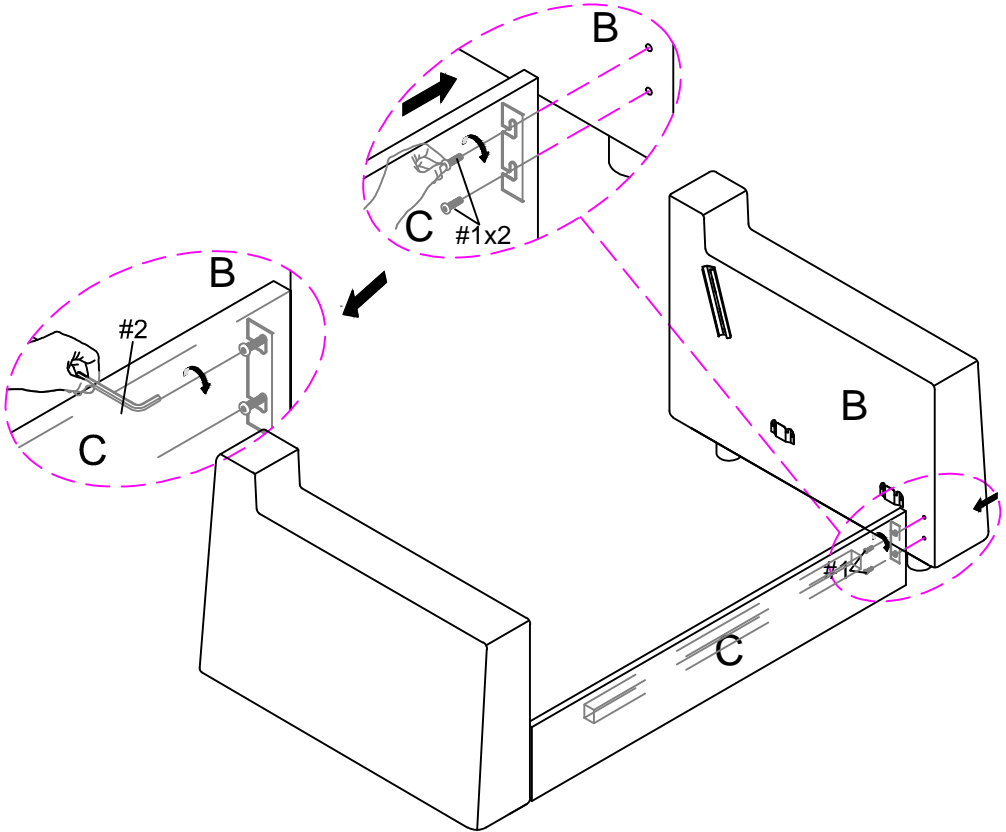
STEP-3



#2	x1
	
M5	

#1	x2
	

ASSEMBLY INSTRUCTIONS

STEP-4

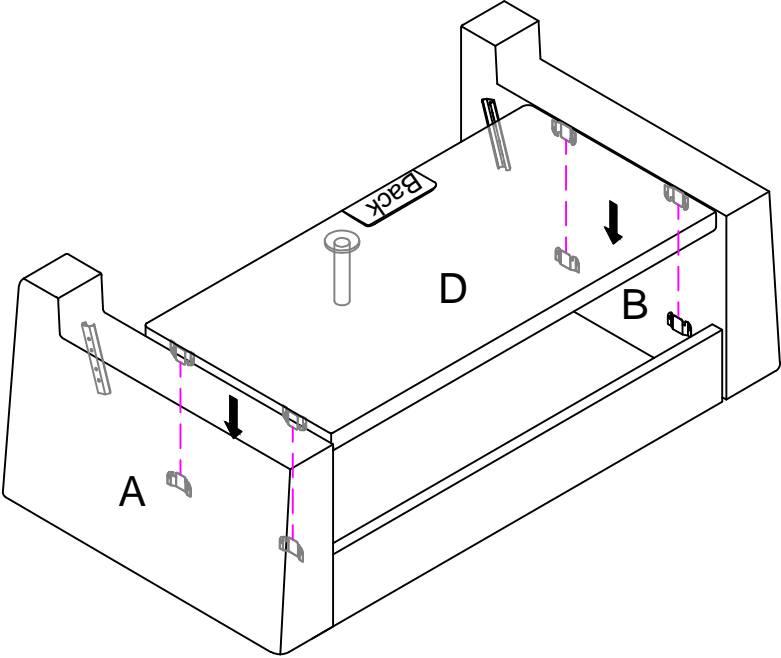

ASSEMBLY INSTRUCTIONS

STEP-5



Be sure to have
adult/partner help to hold
both armrests while
aligning metal brackets on
backrest/armrests

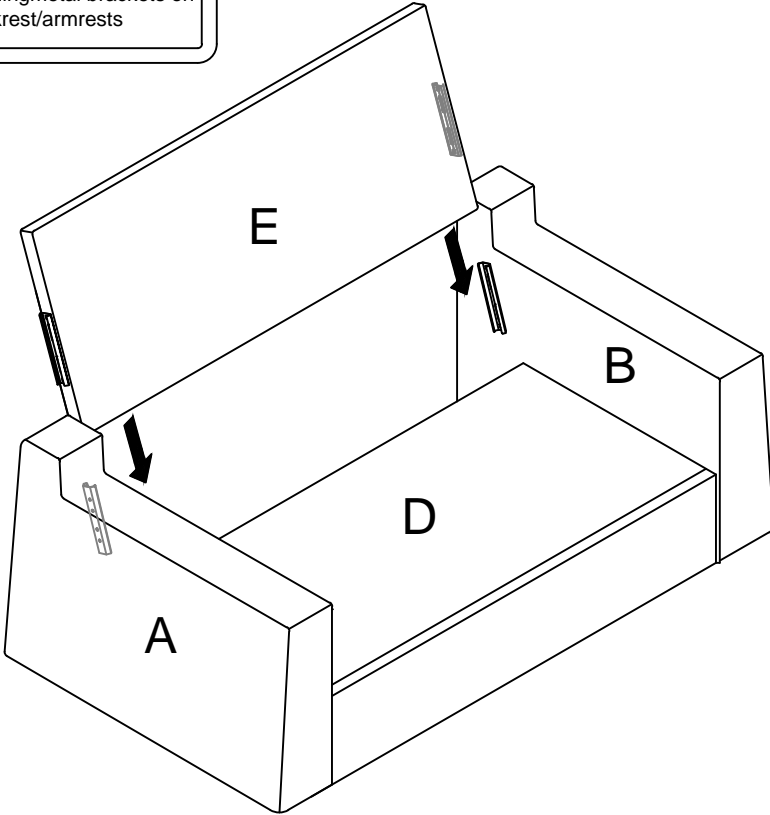

ASSEMBLY INSTRUCTIONS

STEP-6



If necessary, iron the fabric cover with a steam iron to loosen wrinkles. After unpacking all components, allow 48 hours for the compressed foam or polyester pillow fill to spring back. Blowing with a hair dryer or patting the mat with your hands will speed up the process.

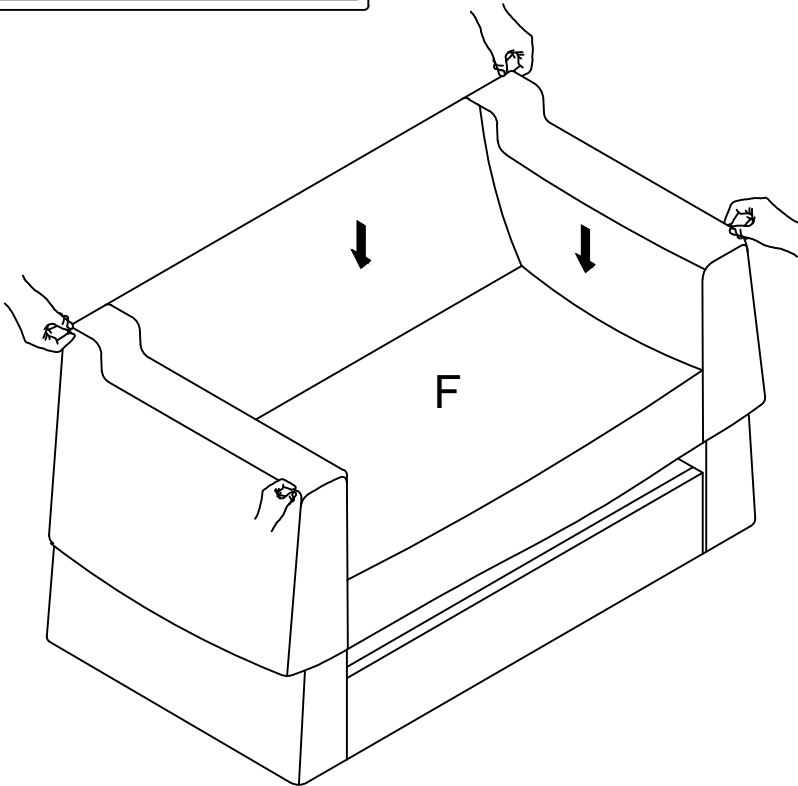

ASSEMBLY INSTRUCTIONS

STEP-7

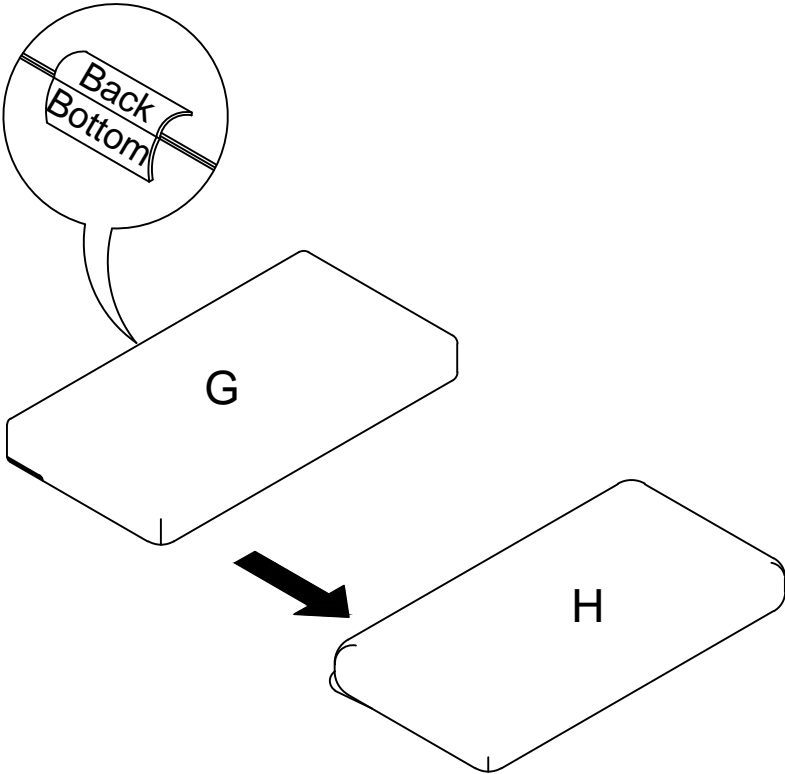

ASSEMBLY INSTRUCTIONS

STEP-8

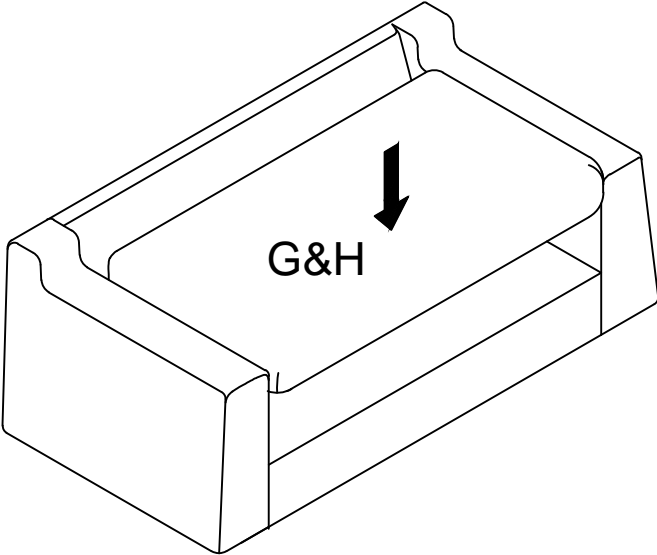

ASSEMBLY INSTRUCTIONS

STEP-9

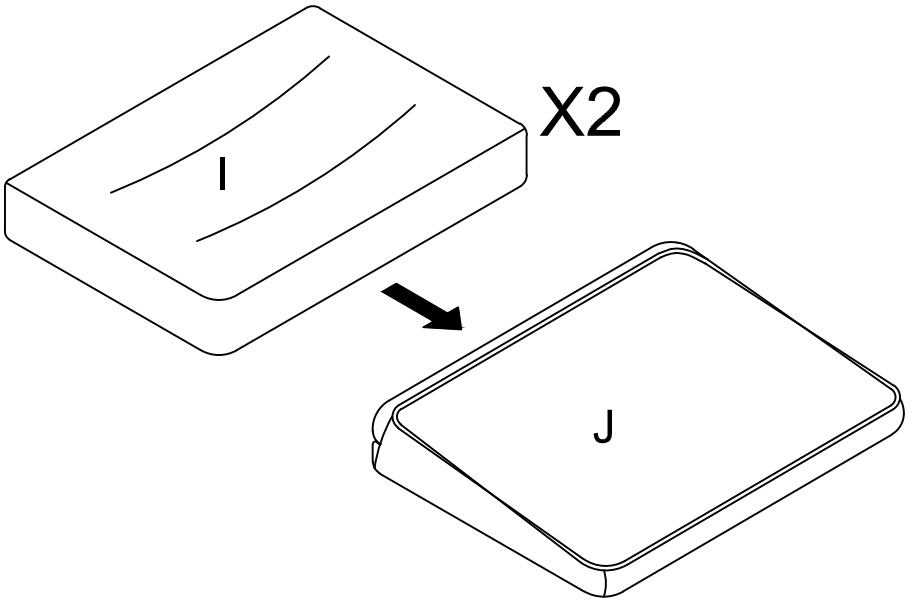

ASSEMBLY INSTRUCTIONS

STEP-10

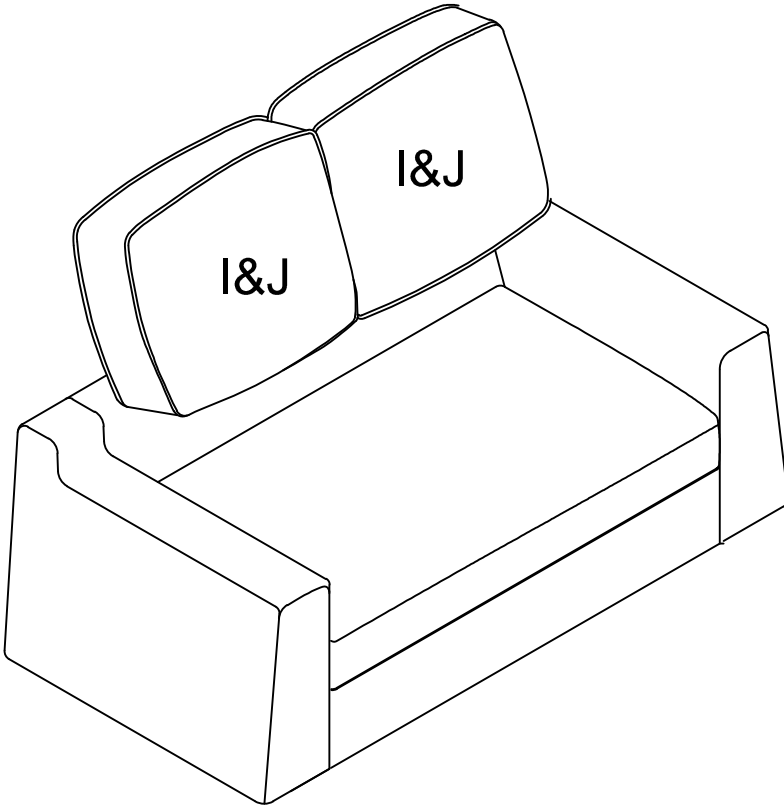

ASSEMBLY INSTRUCTIONS

STEP-11

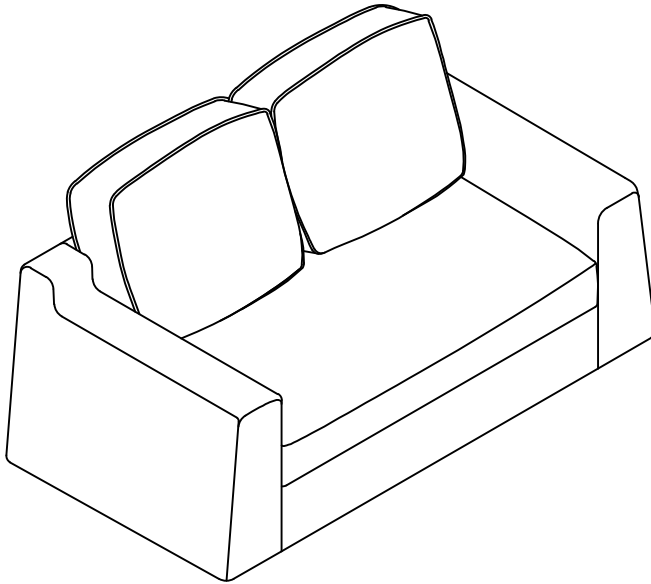

WARRANTY

1. We strive to offer high-quality products, and we also try our best to satisfy each and every customer that orders from us with product or service as needed.
2. We provide 30 days warranty starting from the time you receive the item. Each customer must provide a record of their order such as the order number, or item receipt for any items that are out of the warranty period you may also still receive.
3. Replacement parts by purchasing them with our company if they are available.