

Assembly Instructions

Caution: You must read this before you proceed

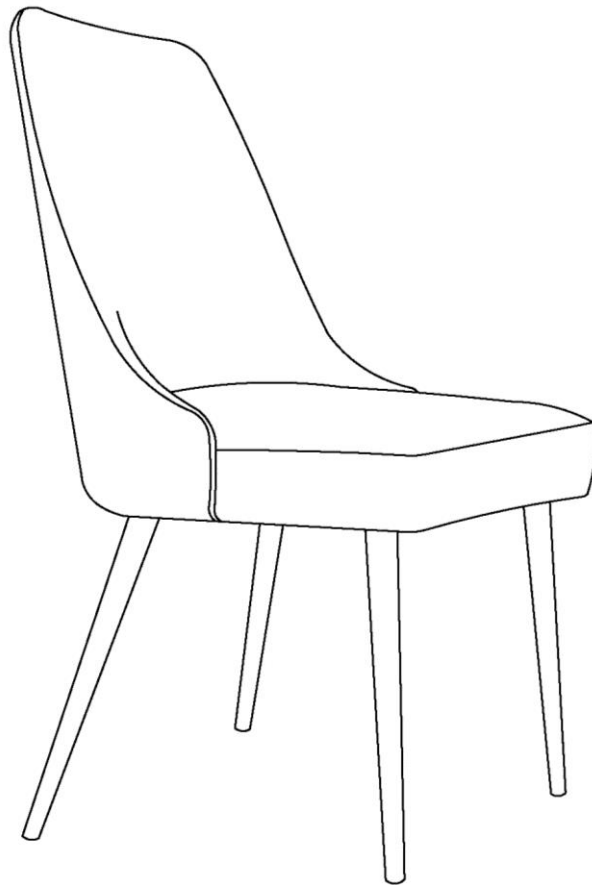



Dining Chair

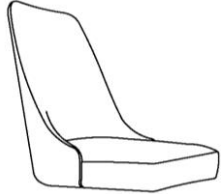
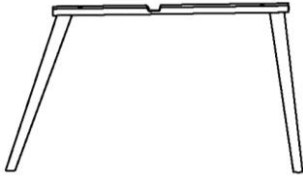
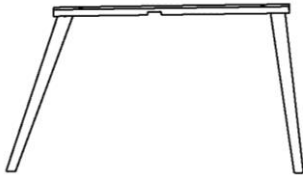

Parts List

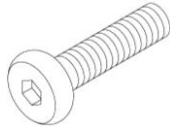
Label	Picture	Description	QTY
A		Seat	1
B		Lower Leg Frame (with Pre-installed levelers)	1
C		Upper Leg Frame (with Pre-installed levelers)	1

Hardware

Label	Picture	Description	QTY
①		Bolt (M6*32mm)	6
②		Spring Washer	6
③		Washer	6
④		Allen Key	1

Assembly Preparation

Before
Beginning
Assembly:

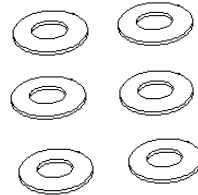
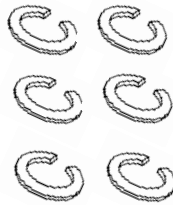
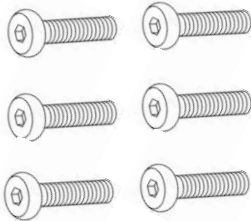
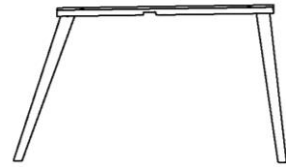
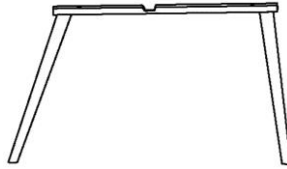
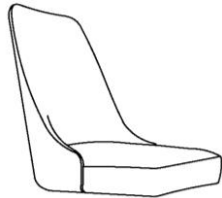

- Read instructions, cover to cover-



- Have 2 adults on hand for assembly-



- Do not assemble on flooring or carpet-



- Assemble on a clean non-marring surface (packing foam)-



- Save all packaging until finished-

Assembly Steps

Overview

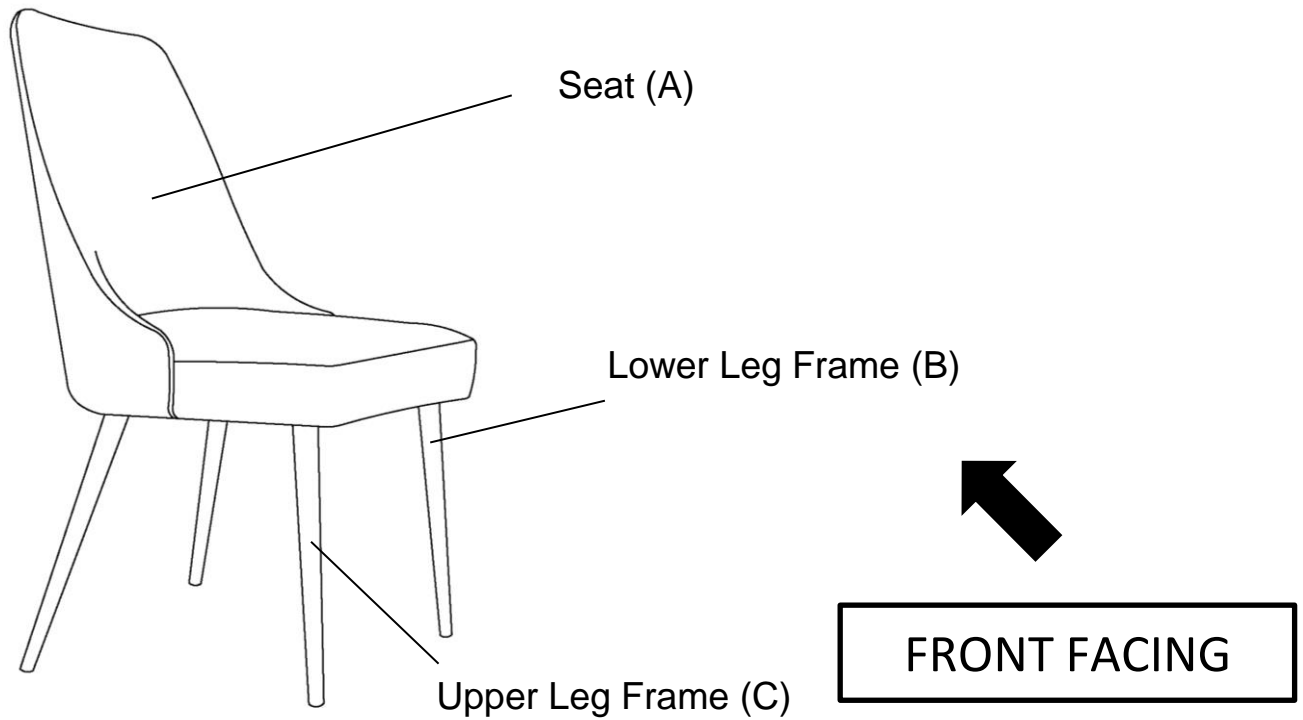

This Dining Chair has multiple parts and may require up to 30 minutes to assemble. To give you an overview of the Dining Chair, the above picture is to help you put the various parts into perspective. Please read through the instructions below to familiarise yourself with the parts and steps before assembly.

Step 1

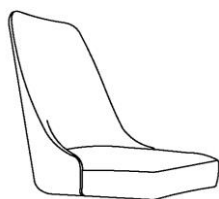

A

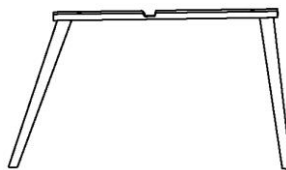

B

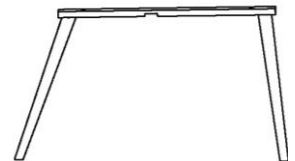

C

Place the Seat(A), Lower Leg Frame(B), and Upper Leg Frame(C) onto a clean, non-marring surface.

Step 2

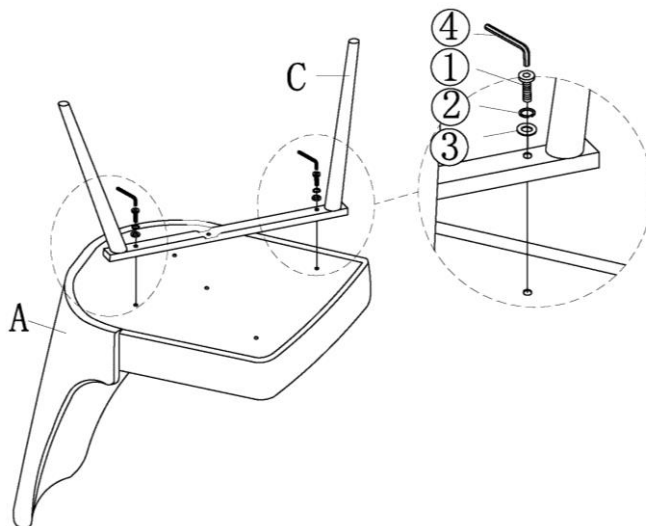

Attach Upper Leg Frame(C) to Seat(A) using Bolts(①), Spring Washers(②) and Washers(③) with Allen Key(④) as shown above.
Tighten the Bolts fully in a sequential manner.

Step 3

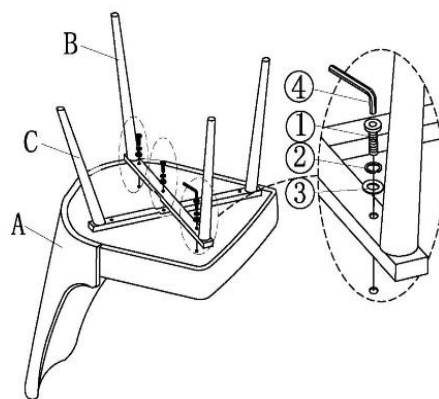

Attach Upper Leg Frame(C) to Lower Leg Frame(B), and Seat(A) using Bolts(①), Spring Washers(②) and Washers(③) with Allen Key(④) as shown above.
Tighten the Bolts fully in a sequential manner.

Step 4

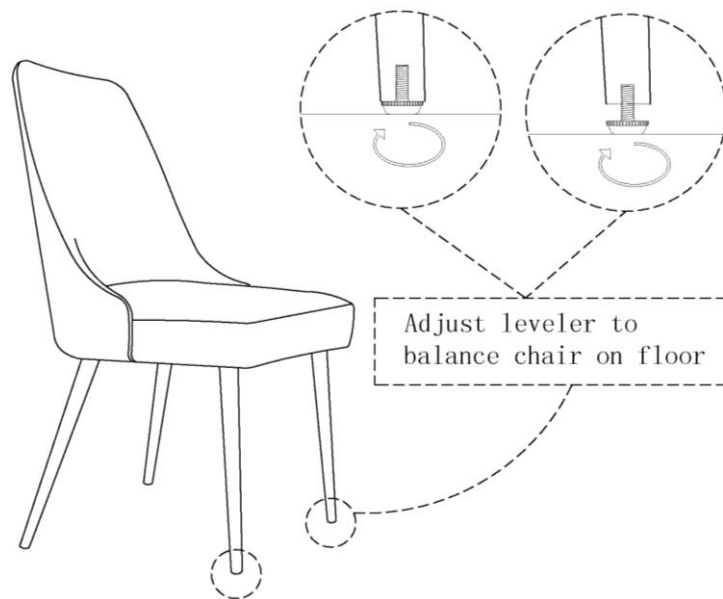











Stand the Dining Chair up.
Adjust the Pre-installed Levelers at the bottom of the Lower Leg Frame(B), and
Upper Leg Frame(C) until the Chair is level with the ground.

Step 5



Your Dining Chair is ready for use.
This Dining Chair can only be used on a flat, level surface.

Care & Maintenance

-  Do not put hot items directly on furniture surface
 -  Do not clean furniture with harsh cleansers or polish.
 -  Do not place furniture under direct sunlight.
 -  Do not place furniture near heating or cooling vents.
 -  Do not write on furniture without a padded barrier to protect the surface.
 -  Do not place furniture outside . For indoor use only .
 -  Not for commercial use. For residential use only .
 -  Stains may be removed with mild soap solution and damp cloth.
 -  Children should not climb or jump on the furniture.
-
-  Dust and pick-up spills using a clean, non-colored, lint-free cloth .