

Installationsanleitung/Installation Instruction/Instruction d'installation/
Istruzioni di installazione/Instrucciones de instalación/
Installatie-instructies/Installationsanvisningar/Instrukcje instalacji
Hochschrank-N620P407782/N620P407783/N620P407784

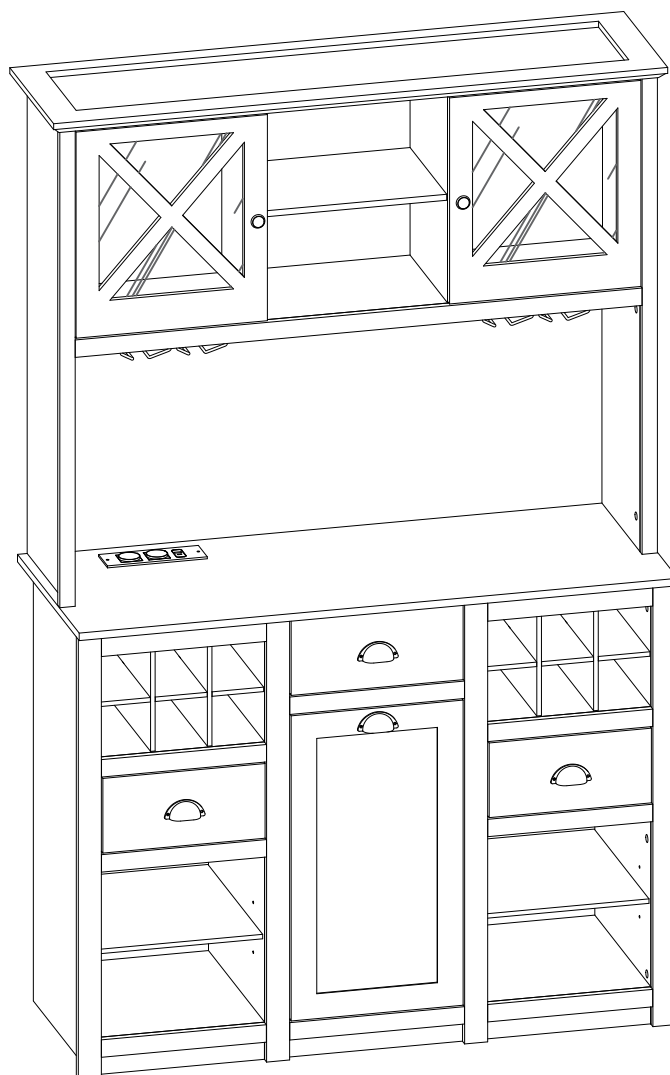

DE: Unser Produkt wird Ihnen in 3 Paketen geliefert. Die Lieferzeiten dieser 3 Pakete können abweichen, bitte haben Sie etwas Geduld und vielen Dank für Ihr Verständnis.

UK: Our product will be delivered to you in 3 packages. The delivery times of these 3 packages may differ, please be patient and thank you for your understanding.

FR: Notre produit vous sera livré en 3 colis. Les délais de livraison de ces 3 colis peuvent différer, soyez patient et merci pour votre compréhension.

IT: Il nostro prodotto verrà consegnato in 3 pacchi. I tempi di consegna di questi 3 pacchi possono variare; vi preghiamo di avere un po' di pazienza e vi ringraziamo per la vostra comprensione.

ES: Nuestro producto se entregará en 3 paquetes. Los tiempos de entrega de estos 3 paquetes pueden variar; por favor, tenga un poco de paciencia y gracias por su comprensión.

NL: Ons product wordt in 3 pakketten bij u geleverd. De levertijden van deze 3 pakketten kunnen verschillen, we vragen om uw geduld en bedanken u voor uw begrip.

SE: Vår produkt kommer att levereras till dig i 3 paket. Leveranstiderna för dessa 3 paket kan variera, vi ber om ditt tålamod och tackar för din förståelse.

PL: Nasz produkt zostanie dostarczony w 3 paczkach. Czas dostawy tych 3 paczek może się różnić, prosimy o cierpliwość i dziękujemy za zrozumienie.

(DE):

1. Die maximale Tragfähigkeit des Produkts beträgt 60 kg, bitte nicht überladen.
2. Lassen Sie Kinder nicht auf Möbel klettern, da dies Umkippen und schwere Verletzungen verursachen kann.
3. Um die Sicherheit zu gewährleisten, installieren Sie bitte gemäß der Anleitung und ziehen Sie bei Bedarf Fachleute zurate.
4. Stellen Sie Möbel nicht in die Nähe von Feuerquellen oder heißen Gegenständen, um das Brandrisiko zu vermeiden.
5. Stellen Sie Möbel nicht in feuchten Umgebungen auf, um Materialschäden zu verhindern.
6. Überprüfen Sie regelmäßig alle Verbindungen und Befestigungen, um sicherzustellen, dass sie fest sind, um Unfälle zu vermeiden.
7. Reinigen Sie Möbel mit einem feuchten Tuch oder Alkohol, vermeiden Sie die Verwendung von reinigenden Mitteln mit ätzenden Chemikalien.

(UK):

1. The maximum weight capacity of the product is 60kg; do not overload.
2. Do not allow children to climb on furniture, as it may cause tipping and serious injury.
3. For safety, please install correctly according to the instructions, and seek professional assistance if necessary.
4. Do not place furniture near fire sources or hot items to avoid fire risk.
5. Do not place furniture in damp environments to prevent material damage.
6. Regularly check all connections and fasteners to ensure they are secure to prevent accidents.
7. Clean furniture with a damp cloth or alcohol; avoid using cleaners with corrosive chemicals.

(FR):

1. La capacité maximale de charge du produit est de 60 kg, ne pas surcharger.
2. Ne laissez pas les enfants grimper sur les meubles, cela peut entraîner un basculement et des blessures graves.
3. Pour garantir la sécurité, veuillez installer correctement selon les instructions et demander de l'aide à des professionnels si nécessaire.
4. Ne placez pas les meubles près de sources de chaleur ou d'objets chauds pour éviter les risques d'incendie.
5. Ne placez pas les meubles dans des environnements humides pour éviter d'endommager les matériaux.
6. Vérifiez régulièrement tous les raccords et fixations pour vous assurer qu'ils sont sécurisés afin d'éviter les accidents.
7. Nettoyez les meubles avec un chiffon humide ou de l'alcool, évitez d'utiliser des nettoyeurs contenant des produits chimiques corrosifs.

(IT):

1. La capacità massima del prodotto è di 60 kg, non sovraccaricare.
2. Non permettere ai bambini di arrampicarsi sui mobili, poiché ciò potrebbe causare ribaltamenti e gravi infortuni.
3. Per garantire la sicurezza, installare correttamente secondo le istruzioni e chiedere assistenza a professionisti se necessario.
4. Non posizionare i mobili vicino a fonti di calore o oggetti caldi per evitare rischi di incendio.
5. Non posizionare i mobili in ambienti umidi per prevenire danni ai materiali.
6. Controllare regolarmente tutte le connessioni e le viti per assicurarsi che siano sicure e prevenire incidenti.
7. Pulire i mobili con un panno umido o alcol; evitare di utilizzare detersivi contenenti sostanze chimiche corrosive.

(ES):

1. La capacidad máxima del producto es de 60 kg, no sobrecargar.
2. No permita que los niños escalen los muebles, ya que puede provocar vuelcos y lesiones graves.
3. Para garantizar la seguridad, instale correctamente según las instrucciones y busque asistencia profesional si es necesario.
4. No coloque muebles cerca de fuentes de fuego u objetos calientes para evitar riesgos de incendio.
5. No coloque muebles en ambientes húmedos para evitar daños en los materiales.
6. Revise regularmente todas las conexiones y sujetadores para asegurarse de que estén firmes y prevenir accidentes.
7. Limpie los muebles con un paño húmedo o alcohol; evite usar limpiadores con productos químicos corrosivos.

(NL):

1. De maximale draagcapaciteit van het product is 60 kg; niet overbelasten.
2. Laat kinderen niet op meubels klimmen, dit kan omvallen en ernstige verwondingen veroorzaken.
3. Installeer correct volgens de instructies voor de veiligheid en vraag indien nodig om professionele hulp.
4. Plaats meubels niet in de buurt van vuurbronnen of hete voorwerpen om brandrisico te voorkomen.
5. Plaats meubels niet in vochtige omgevingen om materiaalschade te voorkomen.
6. Controleer regelmatig alle verbindingen en bevestigingen om ervoor te zorgen dat ze stevig zijn en ongelukken te voorkomen.
7. Maak meubels schoon met een vochtige doek of alcohol; vermijd het gebruik van schoonmaakmiddelen met bijtende

(SE):

1. Den maximala belastningen för produkten är 60 kg; överbelasta inte.
2. Låt inte barn klättra på möbler, eftersom det kan leda till att de tippar och orsakar allvarliga skador.
3. För att säkerställa säkerheten, installera korrekt enligt instruktionerna och be om professionell hjälp vid behov.
4. Placera inte möbler nära värmekällor eller heta föremål för att undvika brandrisk.
5. Placera inte möbler i fuktiga miljöer för att förhindra materialskador.
6. Kontrollera regelbundet alla anslutningar och fästen för att säkerställa att de är säkra för att förhindra olyckor.
7. Rengör möbler med en fuktig trasa eller alkohol; undvik att använda rengöringsmedel med frätande kemikalier.

(PL):

1. Maksymalne obciążenie produktu wynosi 60 kg; nie przeciążaj.
2. Nie pozwalaj dzieciom wspinać się na meble, ponieważ może to prowadzić do przewrócenia i poważnych obrażeń.
3. Aby zapewnić bezpieczeństwo, zainstaluj poprawnie zgodnie z instrukcjami i w razie potrzeby skorzystaj z pomocy specjalistów.
4. Nie stawiaj mebli w pobliżu źródeł ognia lub gorących przedmiotów, aby uniknąć ryzyka pożaru.
5. Nie umieszczaj mebli w wilgotnym środowisku, aby zapobiec uszkodzeniu materiałów.
6. Regularnie sprawdzaj wszystkie połączenia i mocowania, aby upewnić się, że są solidne, aby zapobiec wypadkom.
7. Czyść meble wilgotną szmatką lub alkoholem; unikaj używania środków czyszczących z żrącymi chemikaliami.

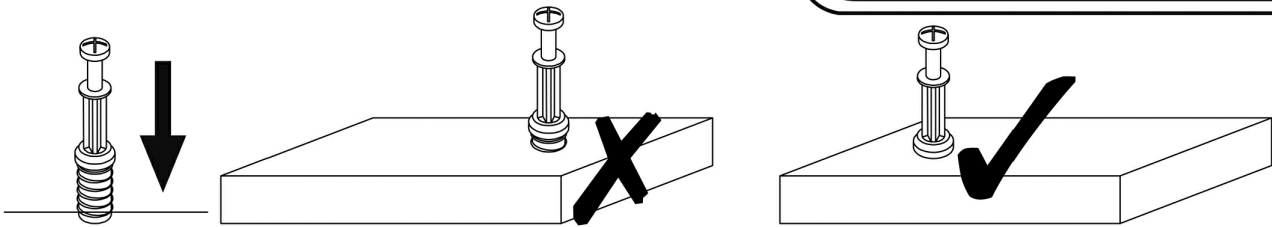

EN_QUICKFIT: Tighten quickfit until shoulder is flush with panel. Do not overtighten or undertighten.

FR_RACCORD RAPIDE: Faites serrer le raccord rapide jusqu'à ce que l'épaulement soit parfaitement encastré dans le panneau. Il ne faut ni trop serrer ni insuffisamment serrer.

ES_QUICKFIT: Apriete quickfit hasta que el hombro se descargue con el panel. NO lo sobreapriete ni lo apriete poco.

DE_QUICKFIT: Ziehen Sie den Quickfit fest, bis die Schulter mit der Platte bündig ist. Bitte nicht zu fest oder zu schwach anziehen.

IT_MONTAGGIO RAPIDO: Stringere il montaggio rapido fino a quando la spalla è a filo con il pannello, non stringere troppo o troppo poco.

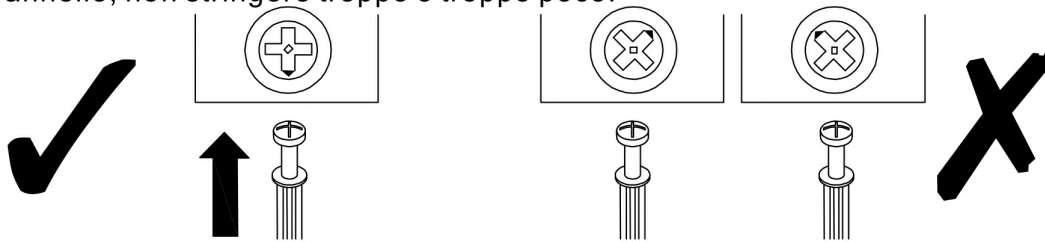

EN_CAM LOCK: When fitting cam lock, ensure starting position is correct before you insert connecting quickfit.

FR_SERRURE BATTEUSE: Avant d'insérer la serrure batteuse, veillez à la bonne orientation avant d'insérer le raccord rapide.

ES_CIERRE DE LA CÁMARA: Cuando instale el cierre de la cámara, asegúrese de que la posición de inicio es correcta antes de que inserte el quickfit conector.

DE_CAM-LOCK: Achten Sie bei der Montage des Cam-Locks auf die richtige Ausgangsposition, bevor Sie den Quickfit einsetzen.

IT_BLOCCAGGIO A CAMMA: Quando si monta il bloccaggio a camma, assicurarsi che la posizione iniziale sia corretta prima di inserire il montaggio rapido di collegamento.

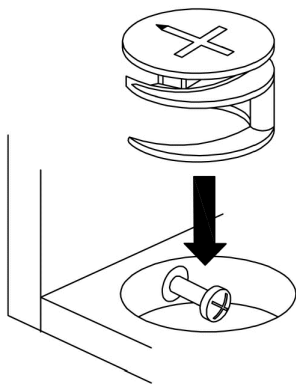

EN_Quickfit head should be in the centre of the cam lock when the two panels are joined.

Cam lock should be inserted before quickfit.

FR_Lorsque les deux panneaux sont assemblés, la tête du raccord rapide doit reposer au centre de la serrure batteuse.

Il faut insérer la serrure batteuse avant le raccord rapide.

ES_El cabezal del quickfit debe estar en el centro del cierre de la cámara cuando se unan los dos paneles.

Se debe insertar el cierre de la cámara antes que el quickfit.

DE_Der Quickfit-Kopf sollte sich in der Mitte des Cam-Locks befinden, wenn die beiden Platten zusammengefügt sind.

Der Cam-Lock sollte vor dem Quickfit eingesetzt werden.

IT_La testa del montaggio rapido deve trovarsi al centro del bloccaggio a camma quando i due pannelli sono uniti.

Il Bloccaggio a Camma deve essere inserito prima del montaggio rapido.

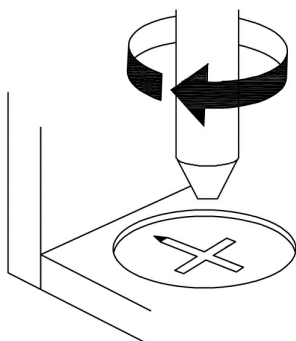

EN_Turn cam lock clockwise to tighten.

FR_Faites tourner la serrure batteuse dans le sens des aiguilles d'une montre pour la resserrer.

ES_Gire el cierre de la cámara en sentido horario para apretarlo.

DE_Drehen Sie den Cam-Lock im Uhrzeigersinn, um ihn festzuziehen.

IT_Ruotare il bloccaggio a camma in senso orario per stringere.

DE: Vor dem Einbau die Schrauben in die Löcher stecken und festziehen, aber nicht bis 100%, 70% bis 80% anziehen reicht aus. Schließlich, nachdem alle Schrauben installiert sind, ziehen Sie alle Schrauben auf 100%. Wenn Sie auf diese Probleme stoßen, wie z. B. Fehlausrichtung der Löcher oder Unfähigkeit, bestimmte Teile zu installieren, überprüfen Sie bitte, ob die Schrauben korrekt verwendet werden und passen Sie die Dichtigkeit der Schrauben an.

UK: Before installation, insert the screws into the holes and tighten them, but do not tighten them to 100%, 70% to 80% is sufficient. Finally, after all screws are installed, tighten all screws to 100%.

If you encounter these issues, such as if the holes cannot be aligned or some parts cannot be installed, please check if the screws are used correctly and adjust the tightness of the screws.

FR: Insérer la vis dans le trou avant la fin de l'assemblage, serrer la vis, mais ne pas serrer à 100%, 70% ~ 80% est correct. Enfin, une fois que toutes les vis sont bien serrées, toutes les vis sont serrées à 100%.

Si vous rencontrez ces problèmes, par exemple si les trous ne sont pas alignés ou si certaines pièces ne peuvent pas être montées, vérifiez que les vis sont utilisées correctement et Ajustez leur serrage.

IT: Prima dell'installazione, inserire le viti nei fori e stringerle, ma non al 100%, è sufficiente stringerle al 70% - 80%. Infine, dopo aver installato tutte le viti, stringere tutte le viti al 100%. Se riscontri problemi come disallineamenti dei fori o difficoltà nell'installare alcuni componenti, verifica che le viti siano utilizzate correttamente e regola la tensione delle viti.

ES: Antes de la instalación, coloque los tornillos en los agujeros y apriéte los, pero no al 100%; apretar al 70% - 80% es suficiente. Finalmente, después de haber instalado todos los tornillos, apriete todos los tornillos al 100%. Si se encuentra con problemas como desalineación de los agujeros o dificultad para instalar ciertas piezas, verifique que los tornillos se estén utilizando correctamente y ajuste la tensión de los tornillos.

NL: Voordat u begint met de installatie, plaatst u de schroeven in de gaten en draait u ze aan, maar draai ze niet volledig aan; 70% tot 80% is voldoende. Draai uiteindelijk, nadat alle schroeven zijn geplaatst, alle schroeven volledig aan. Als u problemen ondervindt, zoals niet uitgelijnde gaten of onderdelen die niet kunnen worden geïnstalleerd, controleer dan of de schroeven correct zijn gebruikt en pas de spanning van de schroeven aan.

SE: Innan installation, sätt i skruvarna i hålen och dra åt dem, men dra inte åt dem helt; 70% till 80% är tillräckligt. Slutligen, när alla skruvar är installerade, dra åt alla skruvar helt. Om du stöter på problem, som att hålen inte kan justeras eller vissa delar inte kan installeras, kontrollera om skruvarna används korrekt och justera skruvarnas åtdragning.

PL: Przed instalacją wstaw śruby w otwory i dokręć je, ale nie dokręcaj ich na 100%; 70% do 80% wystarczy. Na koniec, po zainstalowaniu wszystkich śrub, dokręć wszystkie śruby do 100%. Jeśli napotkasz problemy, takie jak niedopasowane otwory lub części, które nie mogą być zainstalowane, sprawdź, czy śruby są używane prawidłowo i dostosuj ich dokręcenie.

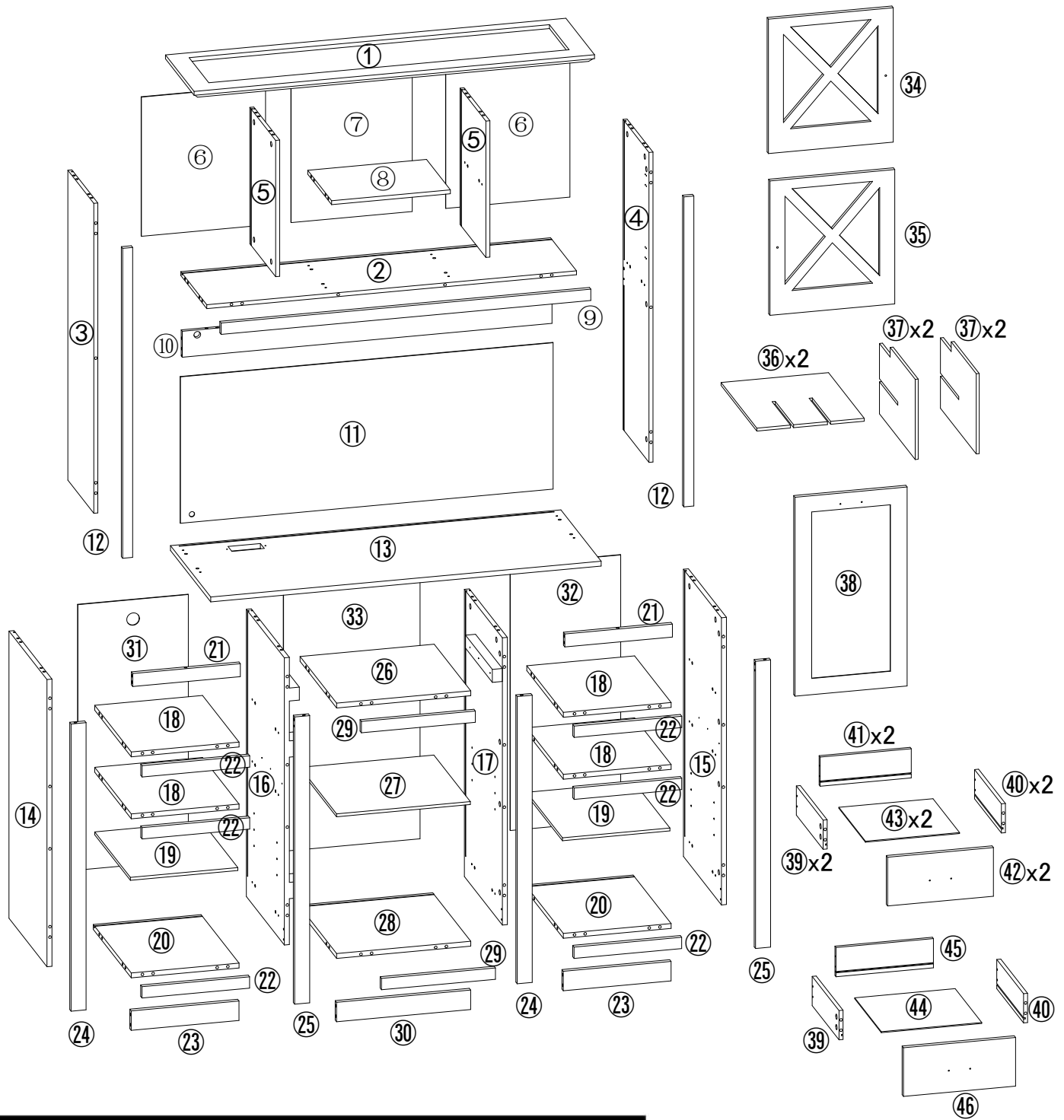

Importeur	Decobus Handel GmbH
Adresse	Innungsstraße 9, 21244 Buchholz, Deutschland
Email/URL	https://www.decobusgroup.de
Hersteller	XIAMENLEADCARGOTRADINGCO.,LTD
Adresse	RM605,YINDUBLDG.,No.9HAITIANROAD,XIAMEN, CHINA
Email/URL	anny@leadcargo.com
Partienummer	N620P407782/N620P407783/N620P407784
Hergestellt in	China
EC REP	Decobus Handel GmbH Innungsstraße 9, 21244 Buchholz, Deutschland https://www.decobusgroup.de

·Komponenten Verschraubungen

Bitte überprüfen Sie, ob Sie alle unten aufgeführten Panels haben.
Hinweis: Die folgende Menge ist die richtige Menge, um die Montage abzuschließen. In einigen Fällen können mehr Armaturen geliefert werden, als erforderlich.

·Composants - accessoires

Veillez vérifier que vous possédez tous les panneaux énumérés ci - dessous.
Remarque: les quantités ci - dessous sont les quantités correspondantes nécessaires pour terminer l'assemblage. Dans certains cas, plus d'accessoires que nécessaire peuvent être fournis.

·Componentes y accesorios

Por favor compruebe que tiene todos los paneles que se enumeran a continuación.
Nota: las cantidades de abajo son la cantidad de correchet para completar el montaje. En algunos casos pueden suministrarse más accesorios de los necesarios.

·Komponenter - kopplingar

Kontrollera att du har alla paneler listade nedan.
Notera: Kvantiteten nedan är det korrekta beloppet för att slutföra monteringen. I vissa fall kan fler kopplingar levereras än vad som krävs.

·Components - fittings

Please check you have all the panels listed below.
Note: The quantity below are the correct amount to complete the assembly. In some cases more fittings may be supplied than are required.

·Componenti - accessori

Controlla di avere tutti i pannelli elencati di seguito.
Nota: i quantitativi indicati di seguito rappresentano il quantitativo corrispondente al completamento del montaggio. In alcuni casi possono essere forniti più accessori di quelli necessari.













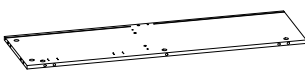
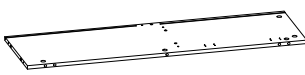

·Componenten - toebehoren

Controleer of u alle panelen hieronder heeft.
Opmerking: de volgende hoeveelheden zijn de juiste hoeveelheid voor de complete montage. In sommige gevallen kunnen er meer accessoires worden geleverd dan nodig is.

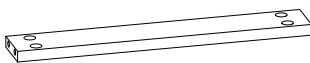





·Komponenty - okucia



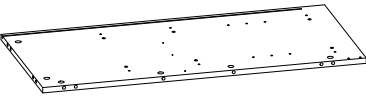
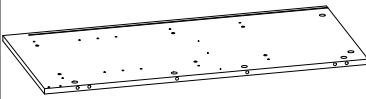
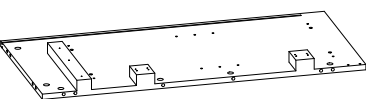
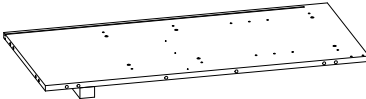
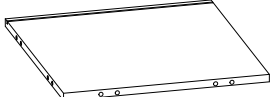



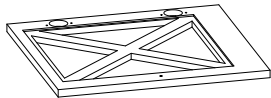
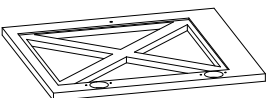



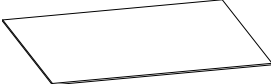
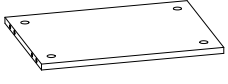
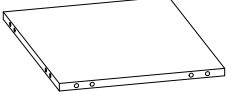

Kontrollera att du har alla paneler listade nedan.
Notera: Kvantiteten nedan är det korrekta beloppet för att slutföra monteringen. I vissa fall kan fler kopplingar levereras än vad som krävs.

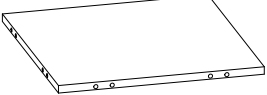
N620P407782 - Box:1/3

			
① x 1pc	② x 1pc	③ x 1pc	④ x 1pc
			
⑨ x 1pc	⑩ x 1pc	⑪ x 1pc	⑫ x 2pcs
			
⑬ x 1pc	⑫ x 6pcs	⑳ x 2pcs	㉔ x 2pcs
			
㉕ x 2pcs	㉑ x 3pcs	㉒ x 3pcs	㉖ x 2pcs
			
㉗ x 1pc			

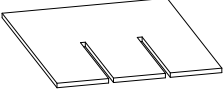
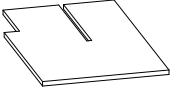
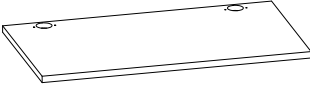
N620P407783 - Box:2/3

			
⑭ x 1pc	⑮ x 1pc	⑯ x 1pc	⑰ x 1pc
			
⑳ x 2pcs	⑳ x 1pc	㉑ x 1pc	㉒ x 1pc
			
㉓ x 1pc	㉔ x 1pc	㉕ x 2pcs	

			
⑤ x 2pcs	⑥ x 2pcs	⑦ x 1pc	⑧ x 1pc
			
⑱ x 4pcs	⑲ x 2pcs	⑳ x 2pcs	㉔ x 1pc
			
㉗ x 1pc	㉘ x 1pc	㉙ x 2pcs	㉚ x 1pc
			
㉜ x 2pcs	㉝ x 4pcs	㉞ x 1pc	㉟ x 2pcs
			
㉫ x 1pc	㉬ x 1pc	Hardware	

·Komponenten Verschraubungen

Bitte überprüfen Sie, ob Sie alle unten aufgeführten Panels haben.
Hinweis: Die folgende Menge ist die richtige Menge, um die Montage abzuschließen. In einigen Fällen können mehr Armaturen geliefert werden, als erforderlich.

·Composants - accessoires

Veillez vérifier que vous possédez tous les panneaux énumérés ci - dessous.
Remarque: les quantités ci - dessous sont les quantités correspondantes nécessaires pour terminer l'assemblage. Dans certains cas, plus d'accessoires que nécessaire peuvent être fournis.

·Componentes y accesorios

Por favor compruebe que tiene todos los paneles que se enumeran a continuación.
Nota: las cantidades de abajo son la cantidad de correchet para completar el montaje. En algunos casos pueden suministrarse más accesorios de los necesarios.

·Komponenter - kopplingar

Kontrollera att du har alla paneler listade nedan.
Notera: Kvantiteten nedan är det korrekta beloppet för att slutföra monteringen. I vissa fall kan fler kopplingar levereras än vad som krävs.

·Components - fittings

Please check you have all the panels listed below.
Note: The quantity below are the correct amount to complete the assembly. In some cases more fittings may be supplied than are required.

·Componenti - accessori

Controlla di avere tutti i pannelli elencati di seguito.
Nota: i quantitativi indicati di seguito rappresentano il quantitativo corrispondente al completamento del montaggio. In alcuni casi possono essere forniti più accessori di quelli necessari.











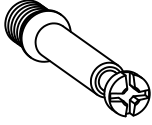



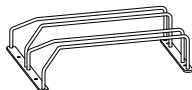
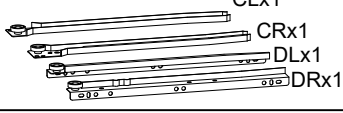

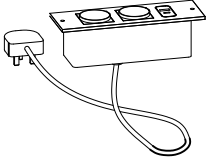
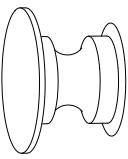

·Componenten - toebehoren

Controleer of u alle panelen hieronder heeft.
Opmerking: de volgende hoeveelheden zijn de juiste hoeveelheid voor de complete montage. In sommige gevallen kunnen er meer accessoires worden geleverd dan nodig is.

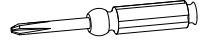
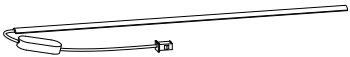
·Komponenty - okucia

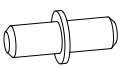



Kontrollera att du har alla paneler listade nedan.
Notera: Kvantiteten nedan är det korrekta beloppet för att slutföra monteringen. I vissa fall kan fler kopplingar levereras än vad som krävs.

Hardware-Liste :N620P407784- Box:3/3

 M6x35mm	 Φ15x9mm	 Φ6x30mm	 M3x12mm
A x 138pcs	B x 138pcs	C x 108pcs	D x 30pcs
		 M3x16mm	
E x 2pcs	F x 3pcs	G x 38pcs	H x 4pcs
		 M4x35mm	
I x 6pcs	J x 28pcs	K x 16pcs	P x 1pc
	 M4x22mm		
Q x 2pcs	R x 2pcs	S x 1 pc	T x 1 pc
		 M4x14mm	
U x 1 pc	V x 12 pcs	W x 44pcs	X x 24pcs
			
Y x 8pcs			

Prevent dumping of spare parts+ N620P407784 - Box:3/3

	 M4x35mm	 M4x16mm	
L x 2pcs	M x 2pcs	N x 2pcs	O x 2pcs

 M3x12mm	 M3x16mm	 M4x35mm	 M4x35mm
D x 62pcs	G x 28pcs	K x 28pcs	M x 2pcs
 M4x16mm			
N x 2pcs			

DE: Bitte beachten Sie, dass die Formen der Schrauben D und G und K und M und N ähnlich sind. Bitte installieren Sie entsprechend der Anleitung und unterscheiden Sie sie!

UK: Please note that the shapes of screws D and G and K and M and N are similar. Please install according to the instructions and distinguish them!

FR: Notez que les vis D et G et K et M et N ont des formes similaires. Veuillez les installer en suivant les instructions pour les séparer!

IT: Si prega di notare che le forme delle viti D , G , K , M e N sono simili. Si prega di installarle seguendo le istruzioni e di distinguerle!

ES: Por favor, tenga en cuenta que las formas de los tornillos D , G , K , M y N son similares. Por favor, instálelos de acuerdo con las instrucciones y distíngalos.

NL: Let op, de vormen van schroeven D , G , K , M en N zijn vergelijkbaar. Installeer volgens de instructies en maak onderscheid tussen ze!

SE: Observera att formerna på skruvarna D , G , K , M och N är lika. Installera enligt anvisningarna och särskilj dem!

PL: Zauważ, że kształty śrub D , G , K , M i N są podobne. Zainstaluj zgodnie z instrukcjami i rozróżnij je!

1.

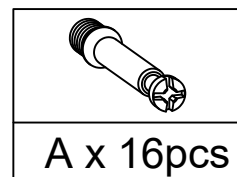
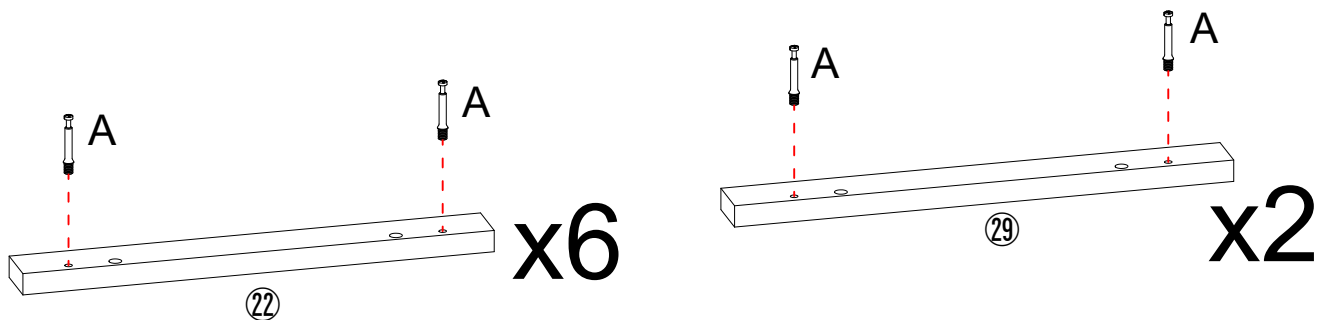

2.

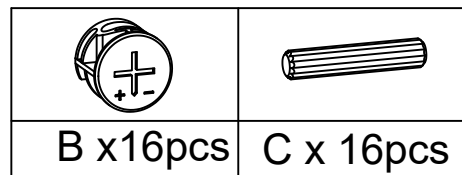
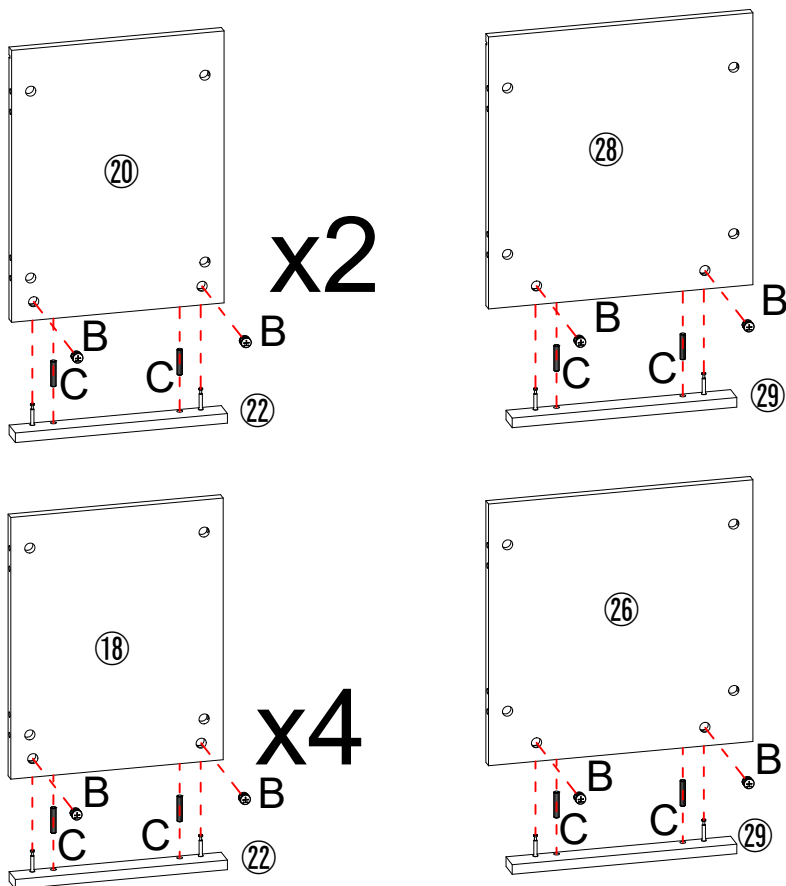

3.

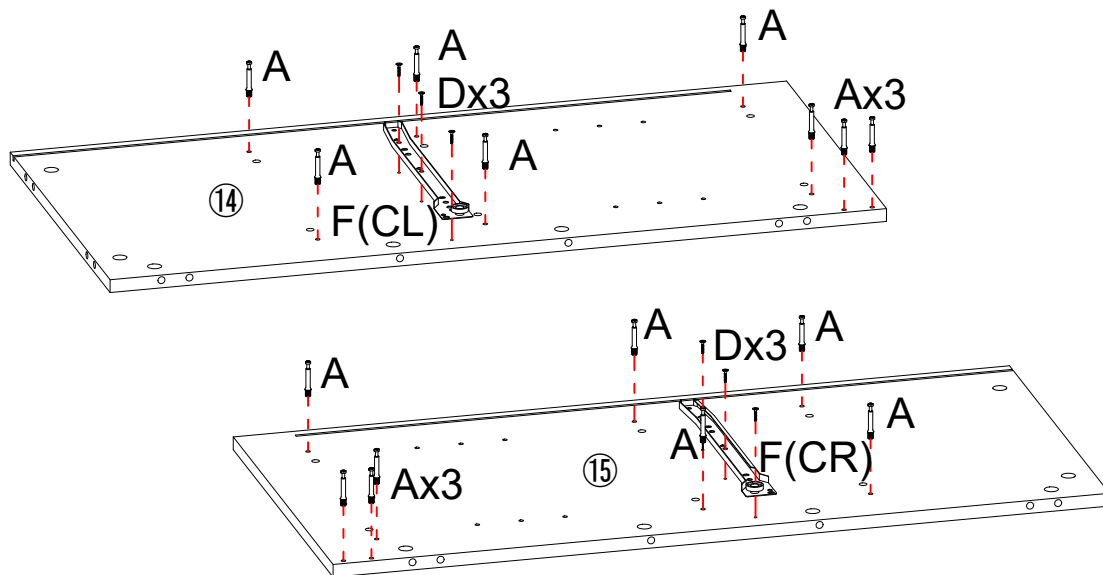
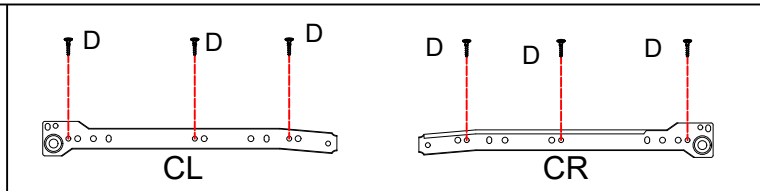

A x 16pcs	D x 6pcs	F

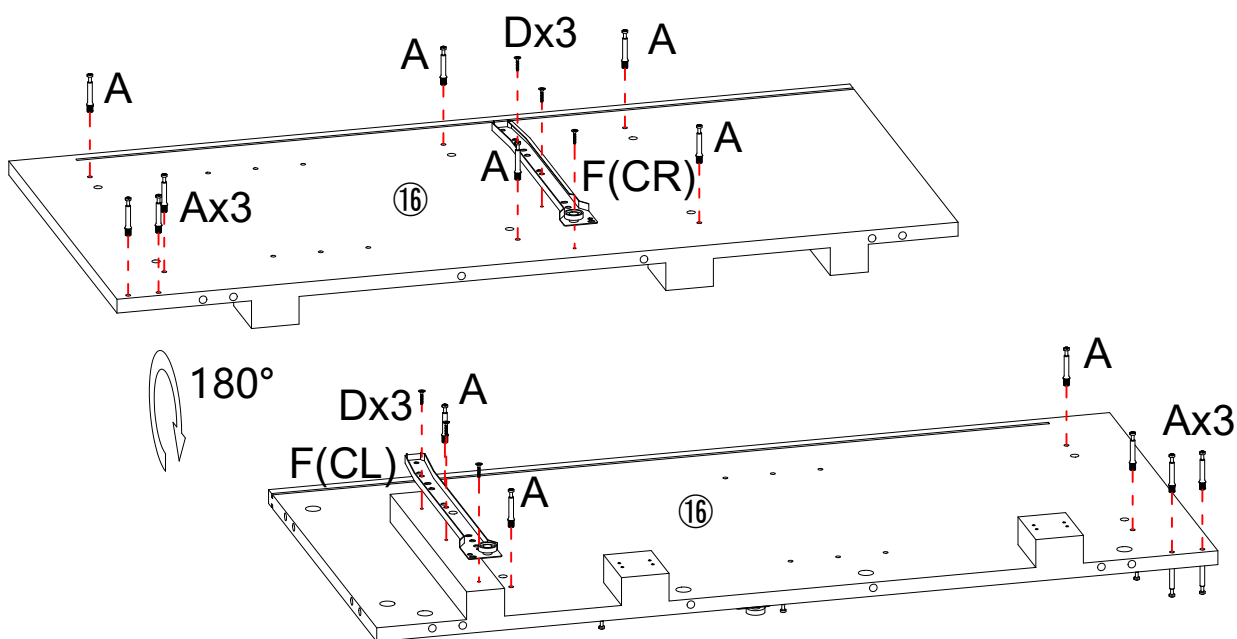
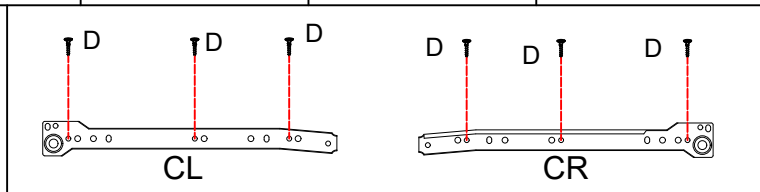

4.



A x 14pcs	D x 6pcs	F

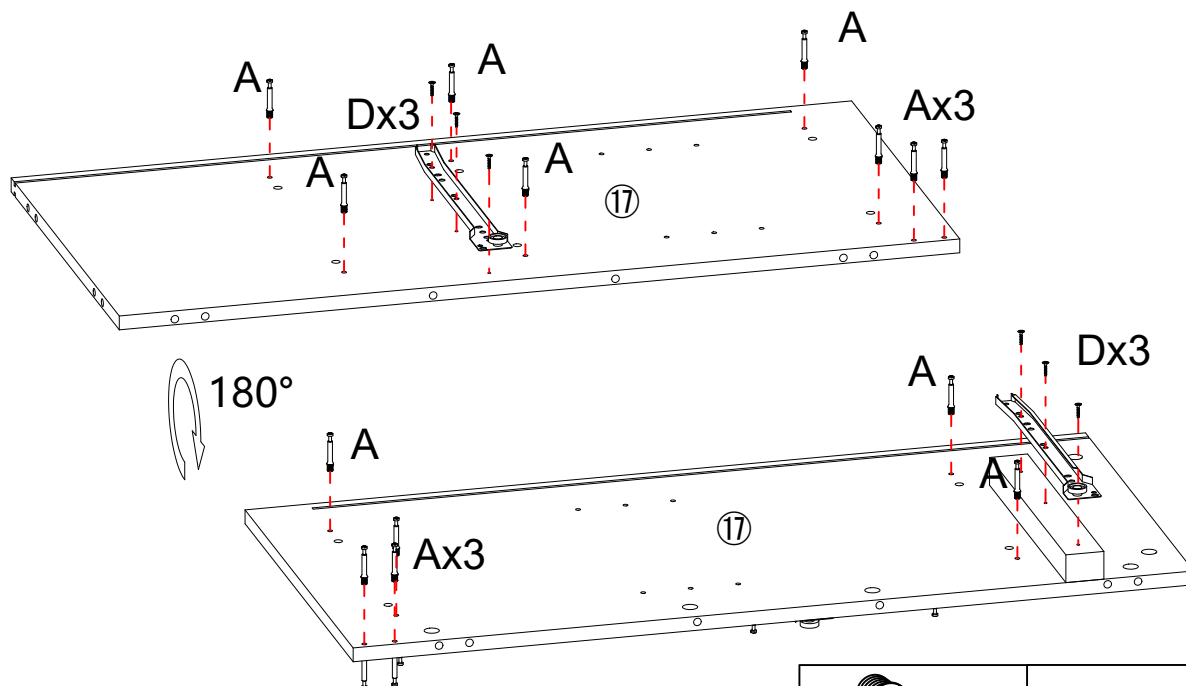
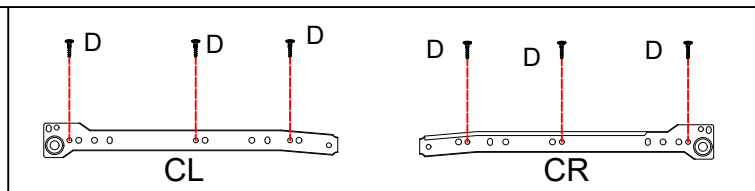

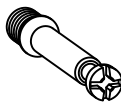
5.

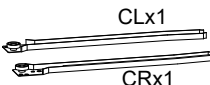

		
A x 14pcs	D x 6pcs	F

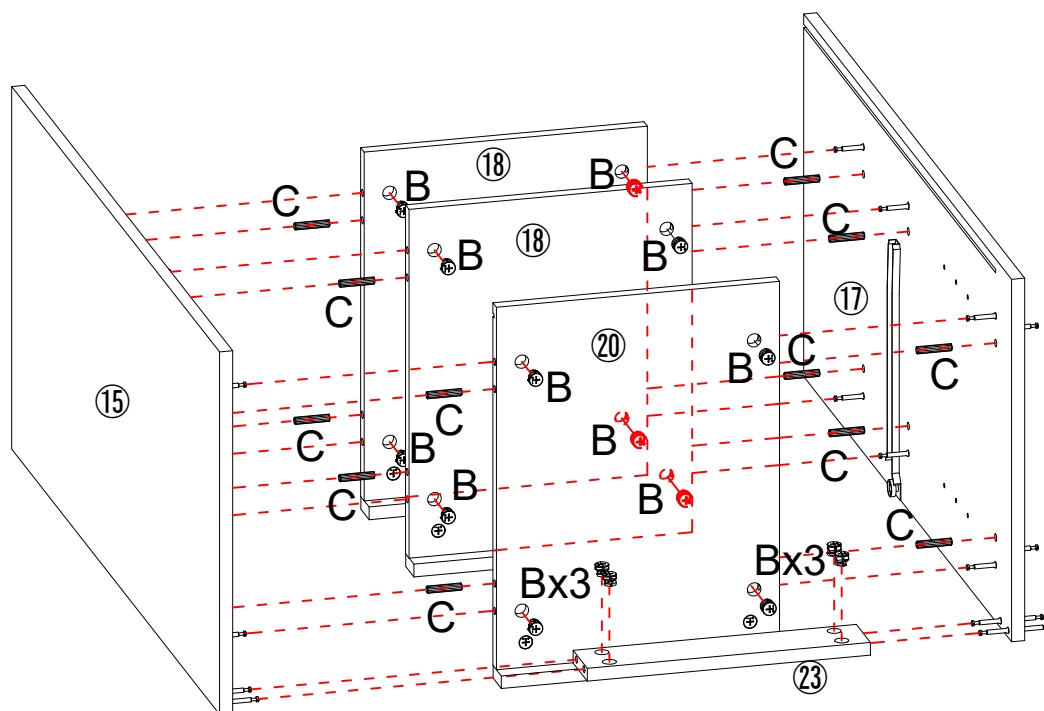

6.



	
B x 16pcs	C x 12pcs

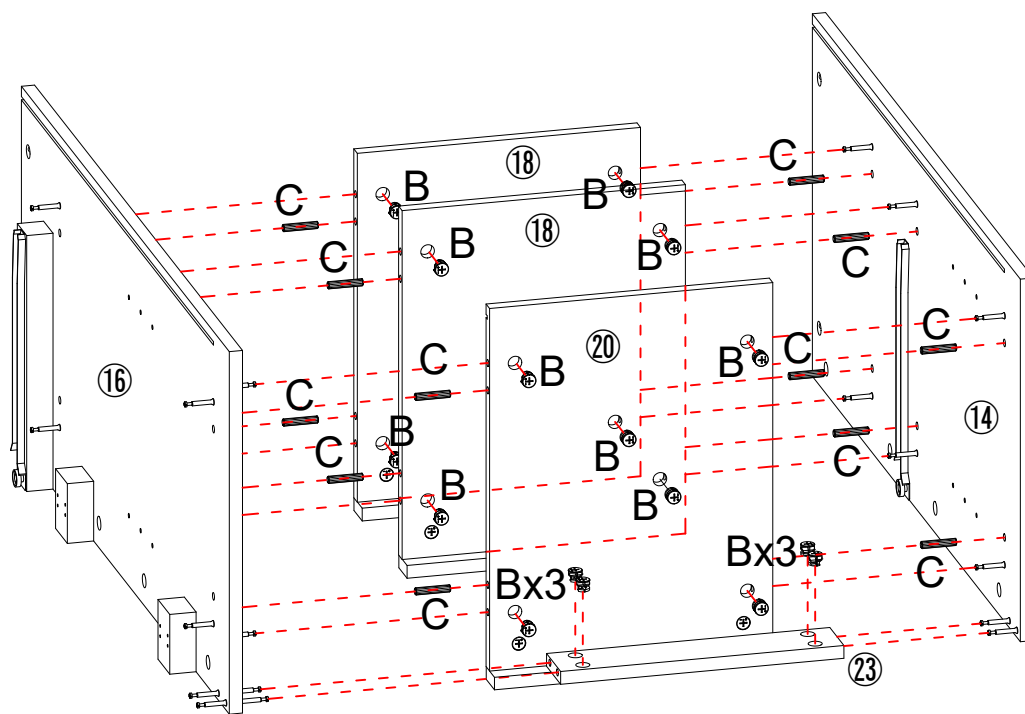

7.

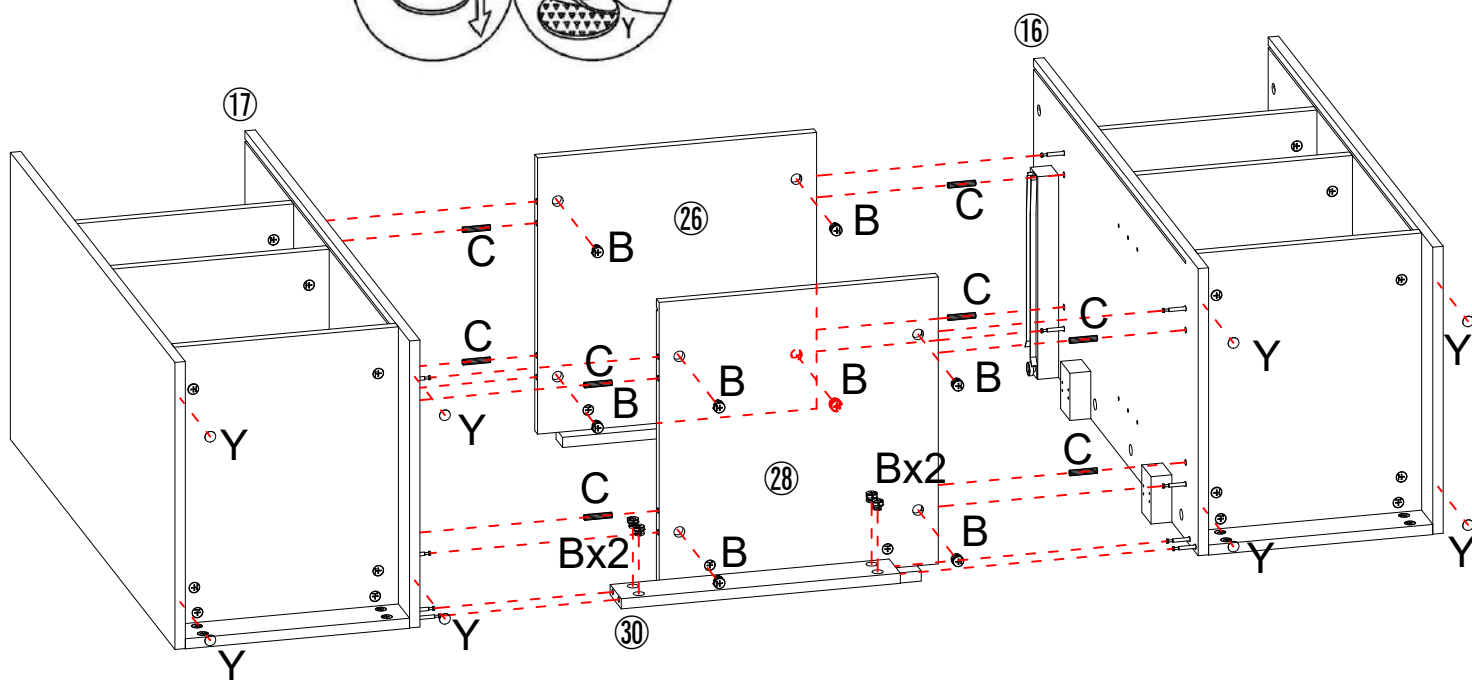
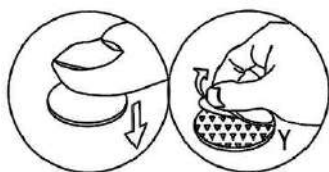

	
B x 16 pcs	C x 12 pcs

8.



		
B x 12 pcs	C x 8 pcs	Y x 8 pcs

9.

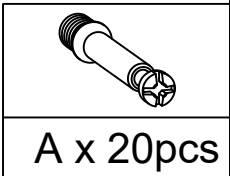
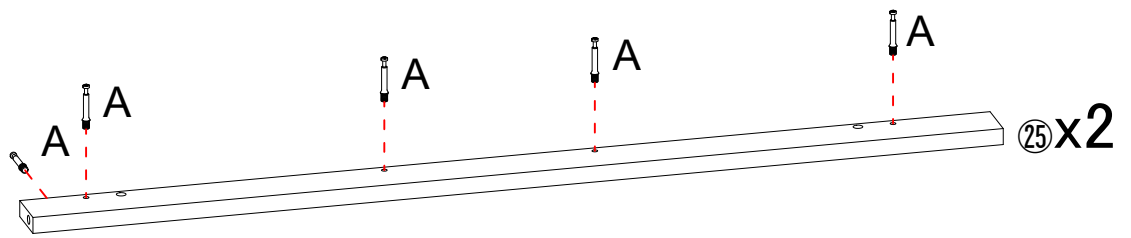
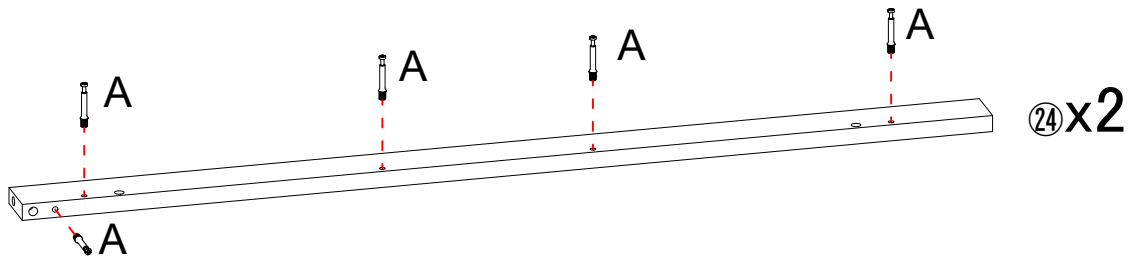

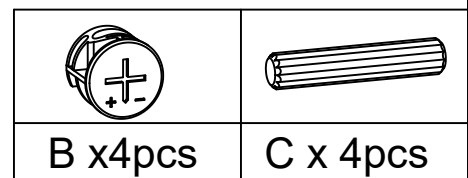
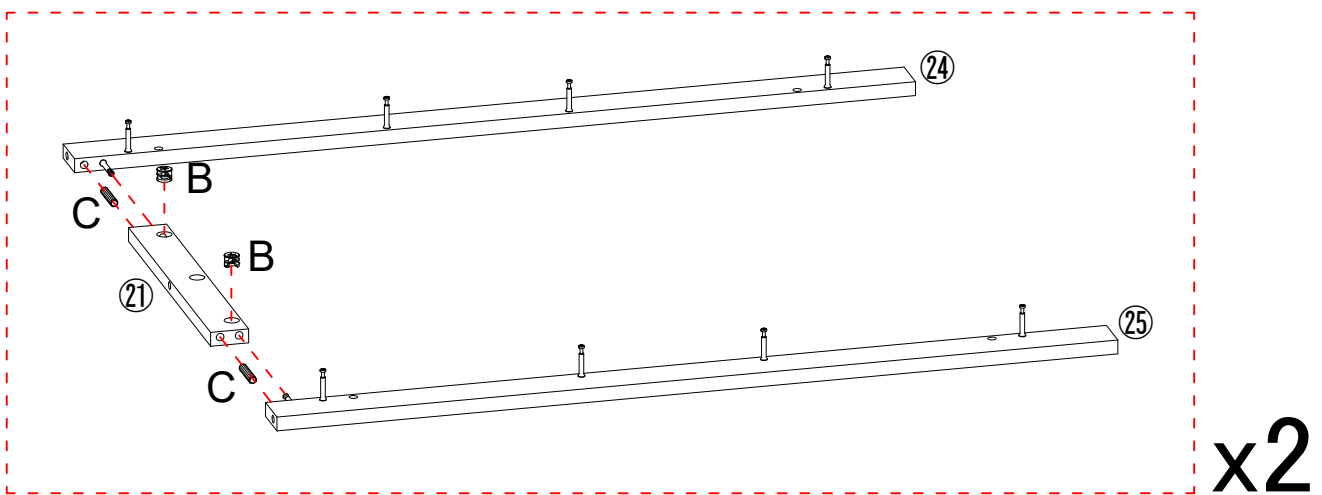

10.

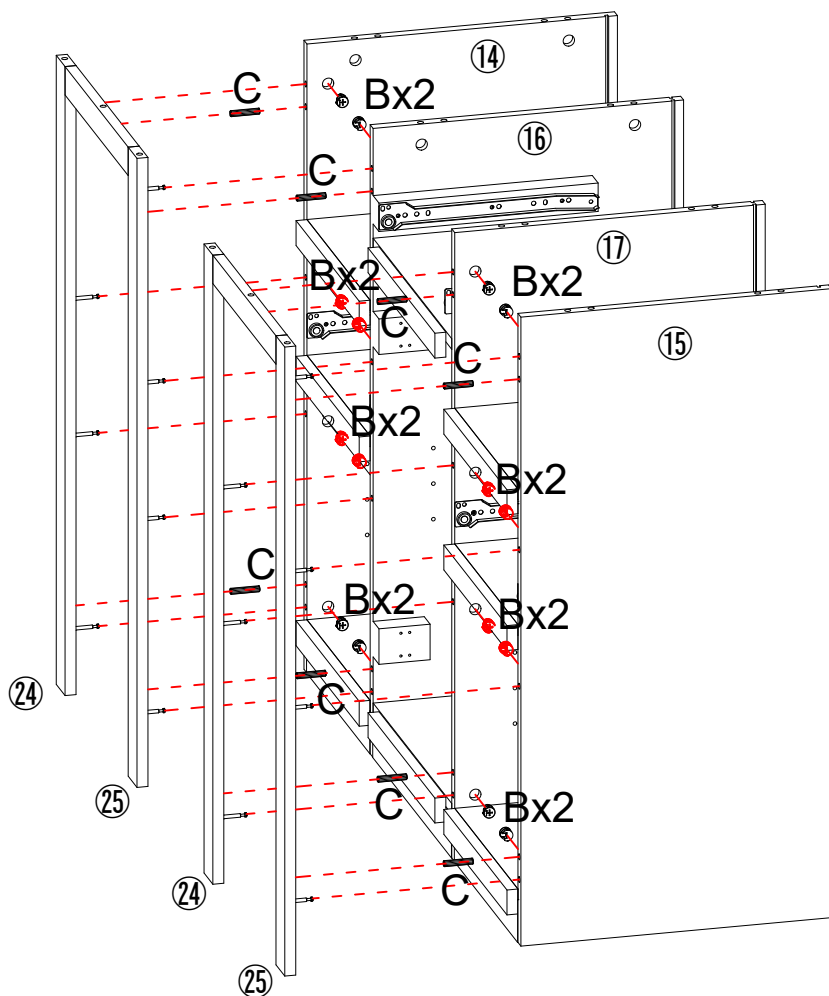

11.



	
B x 16 pcs	C x 8 pcs

12.

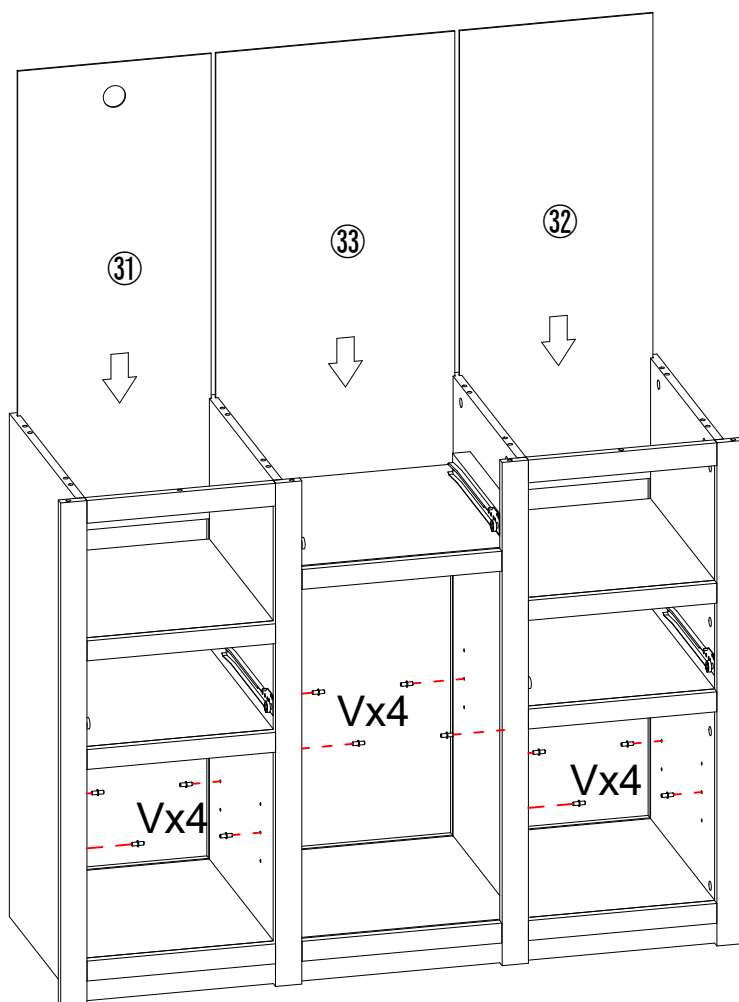

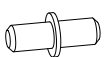

V x 12 pcs

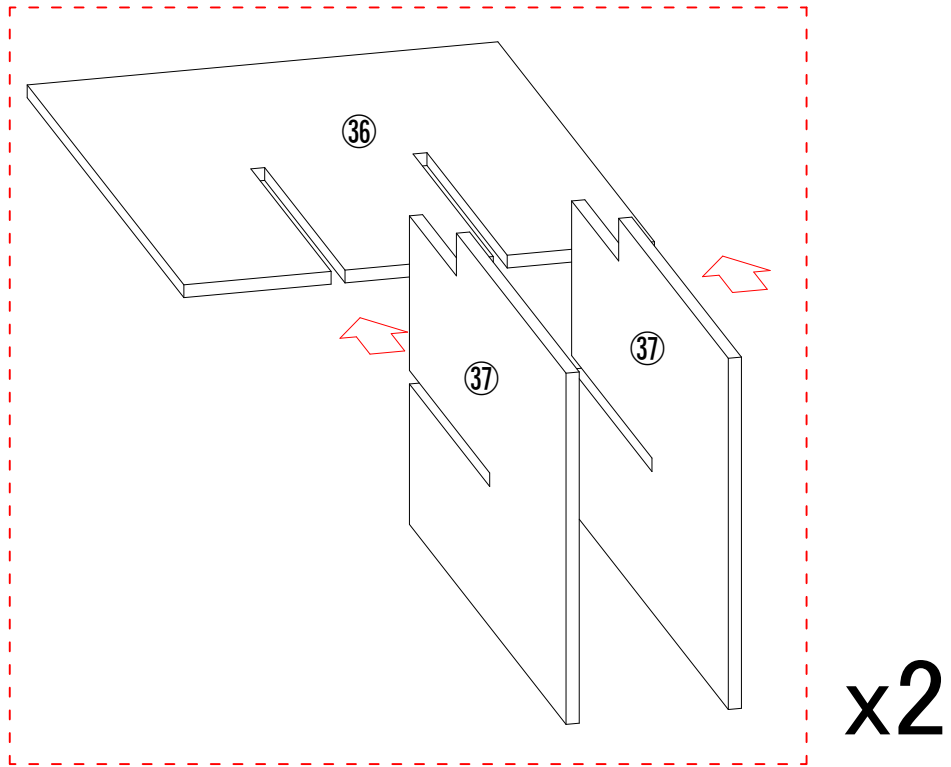
13.

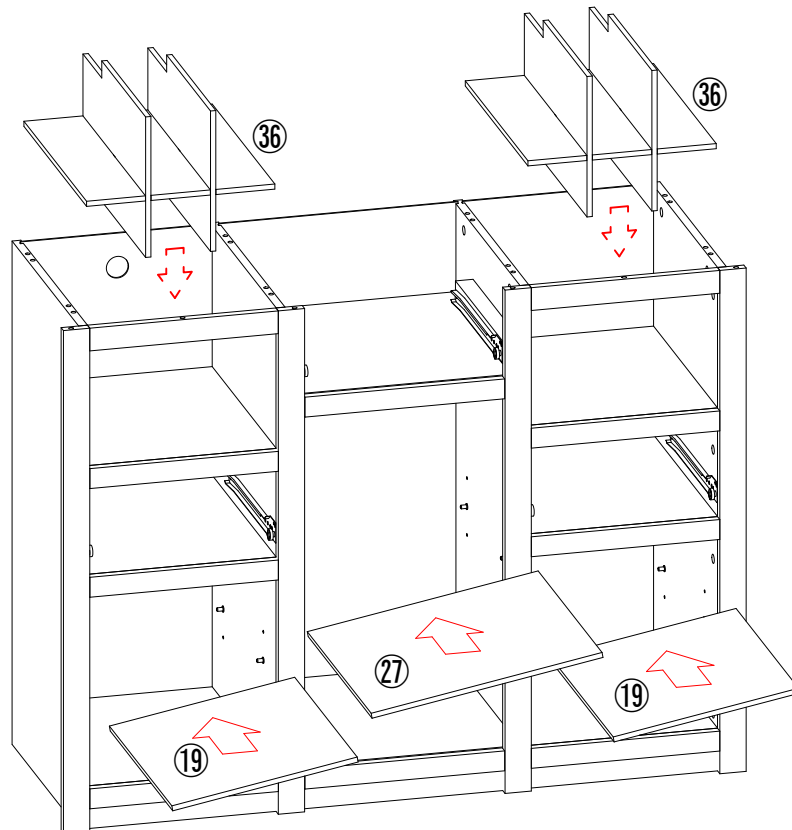

14.



15.

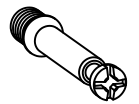
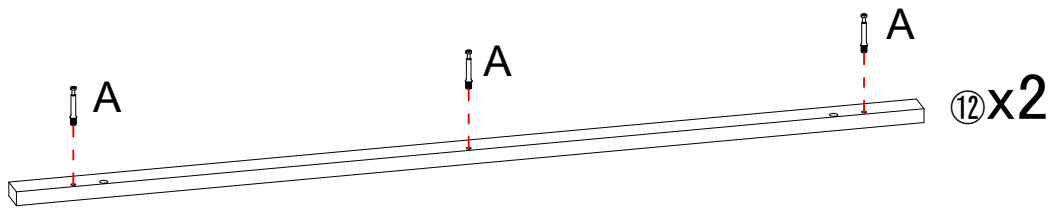
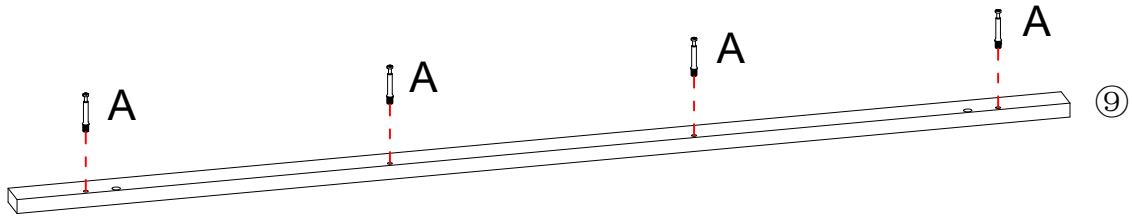

A x 10pcs

16.

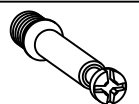
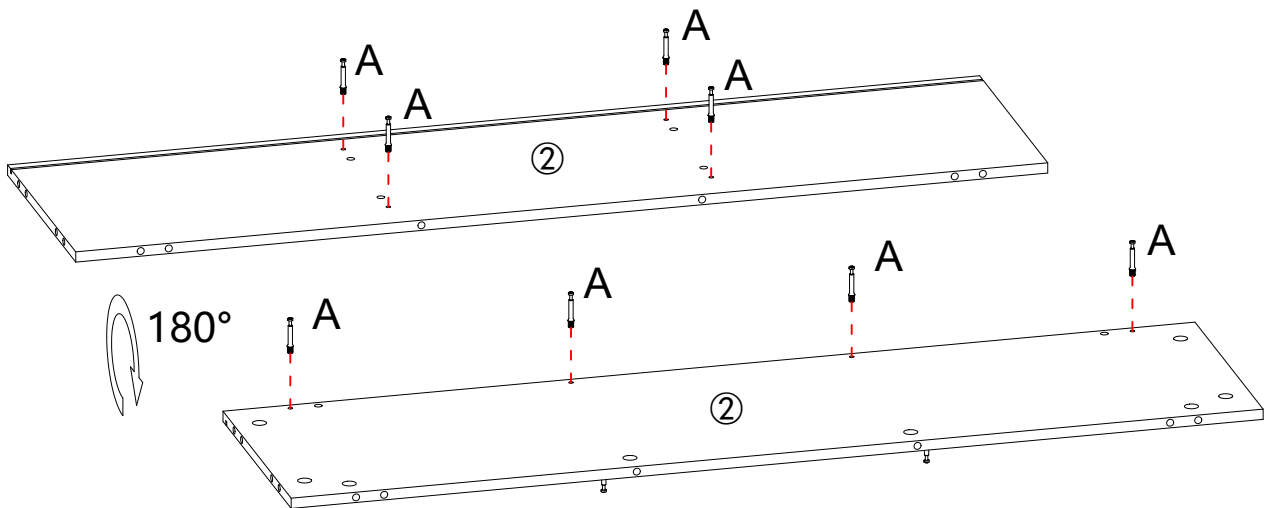

A x 8pcs

17.

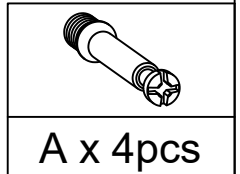
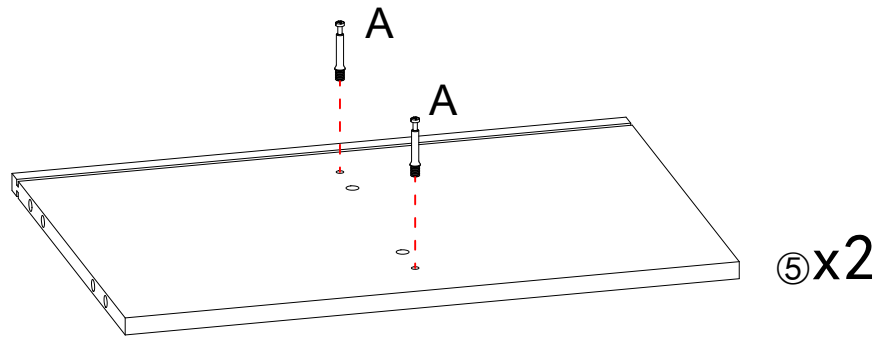

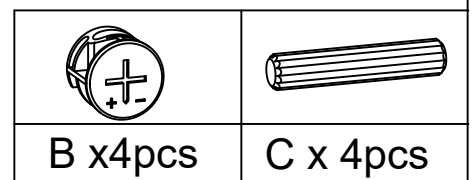
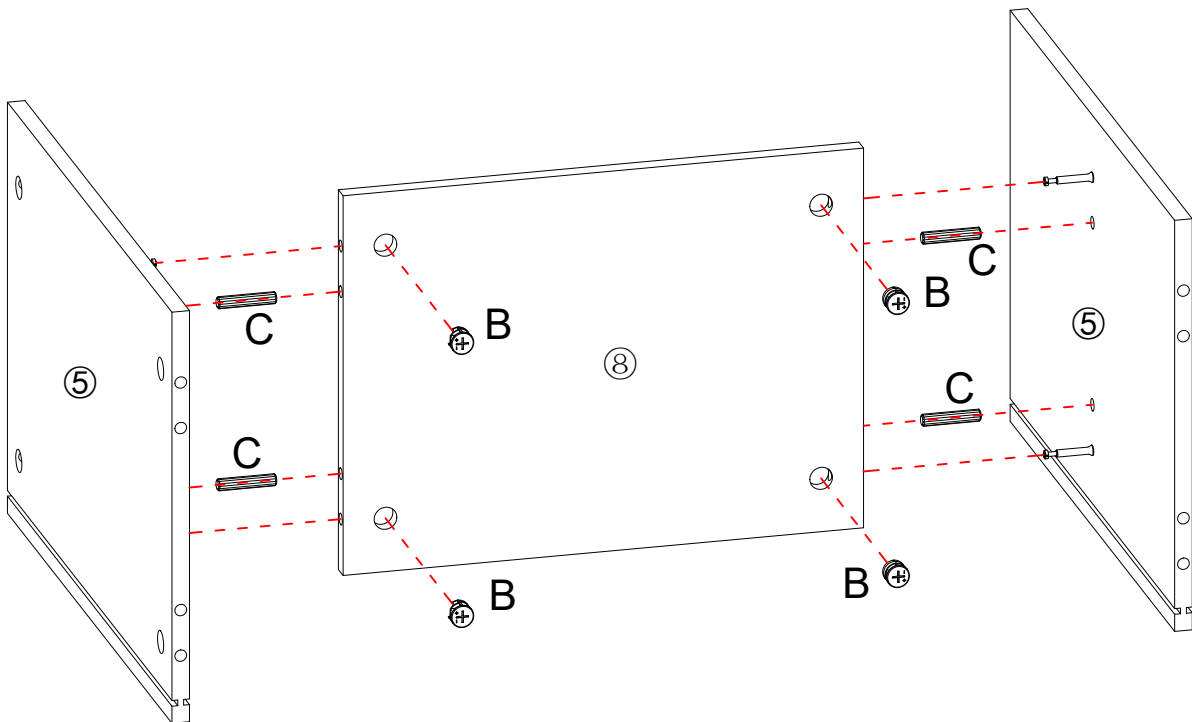

18.



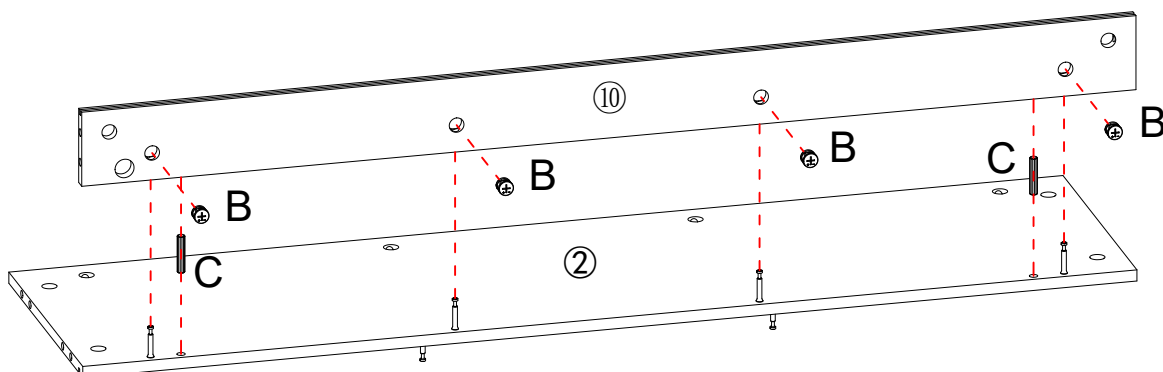



19.

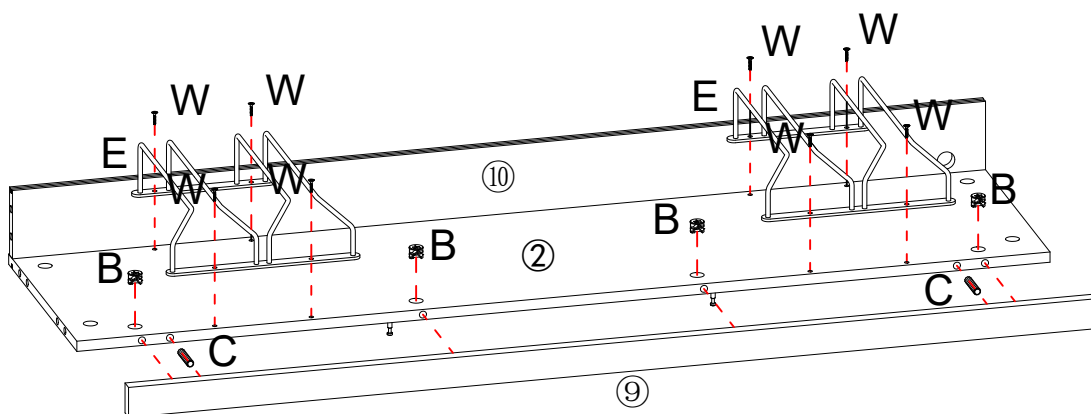

	
B x4pcs	C x 2pcs

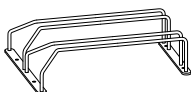

20.

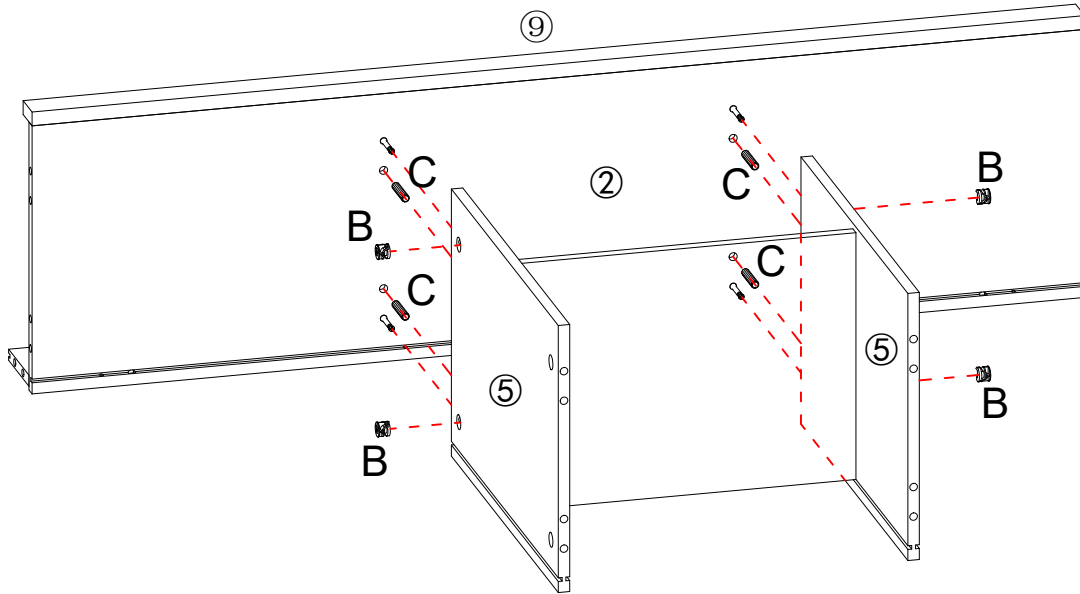

			
B x4pcs	C x 4pcs	E x 2pcs	M4x14mm
			W x 8pcs

21.



	
B x4pcs	C x 4pcs

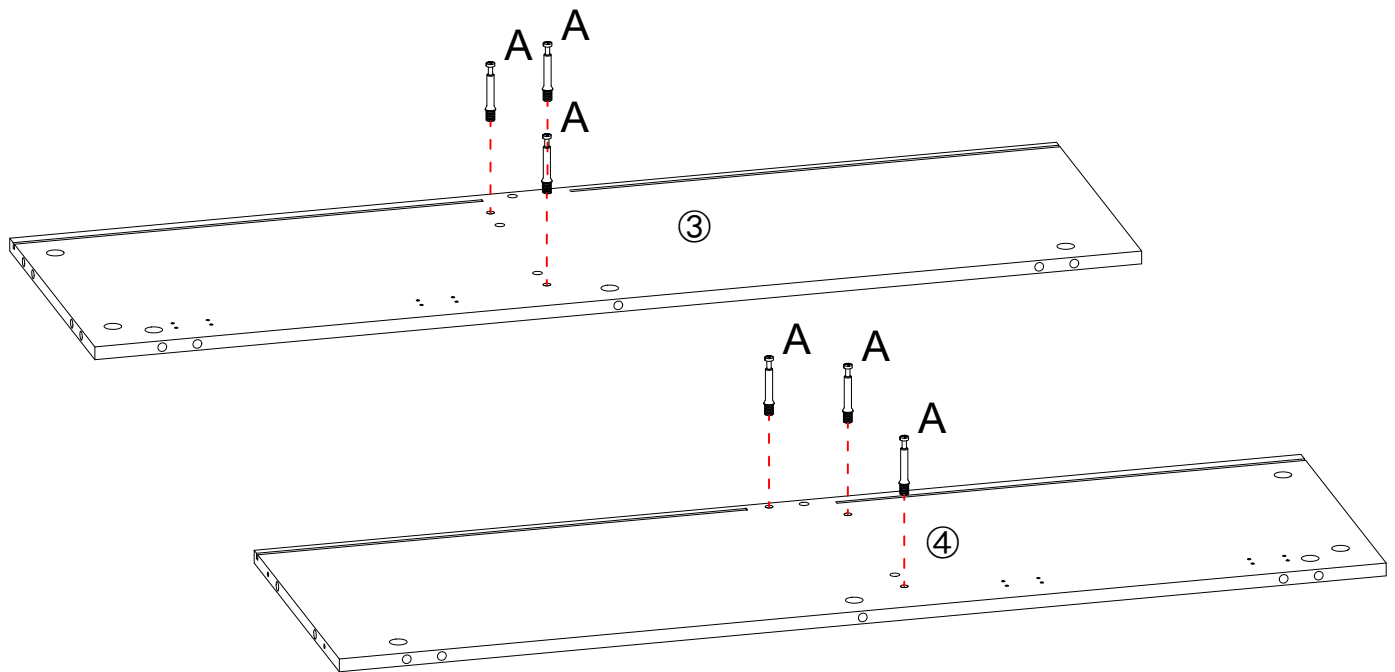

22.

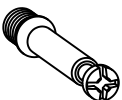

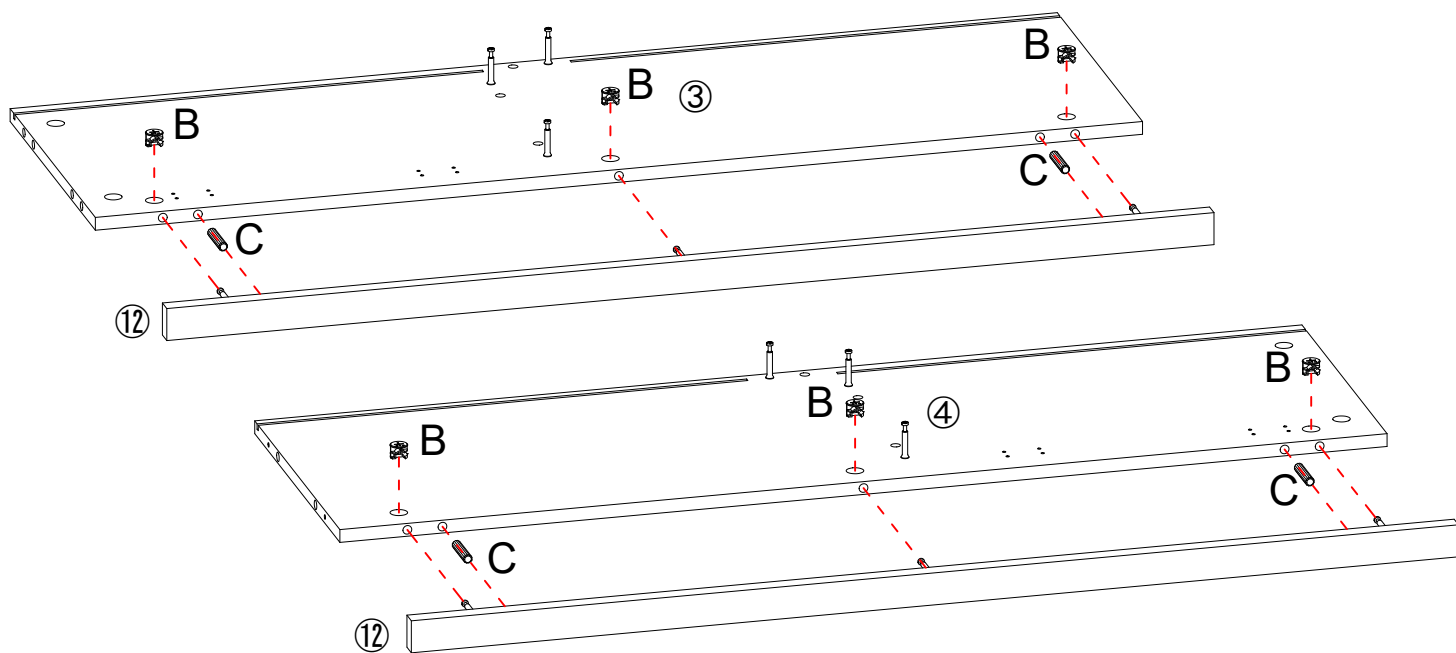

A x 6pcs



23.

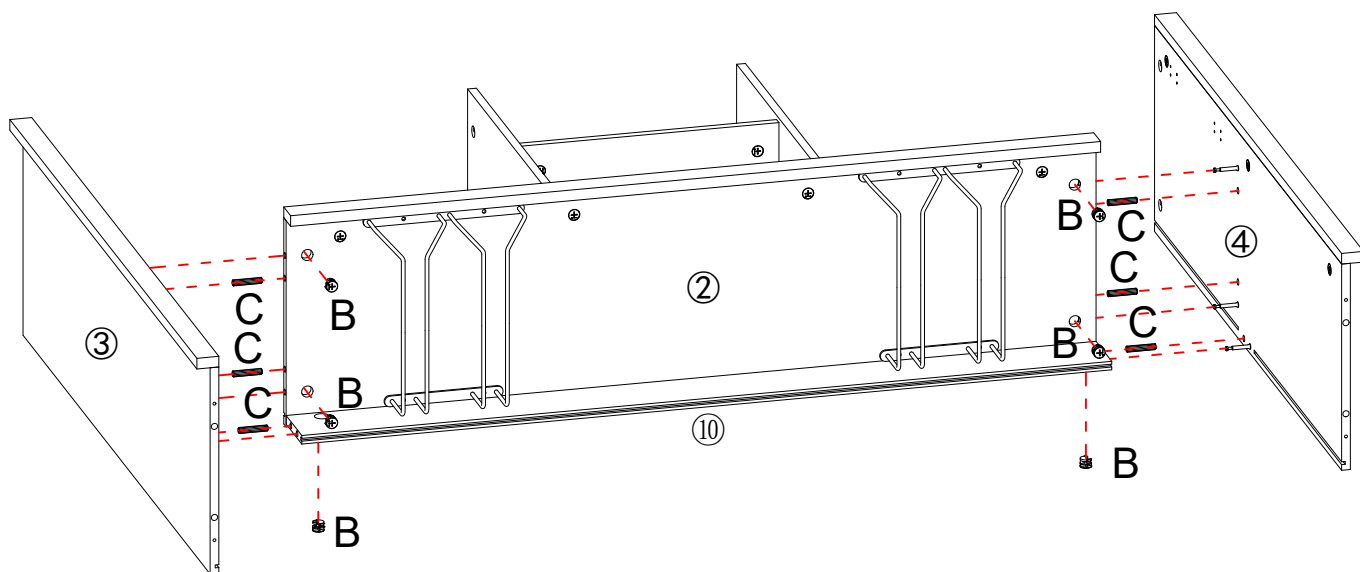

	
B x6pcs	C x4pcs

24.



	
B x6pcs	C x 6pcs

25.

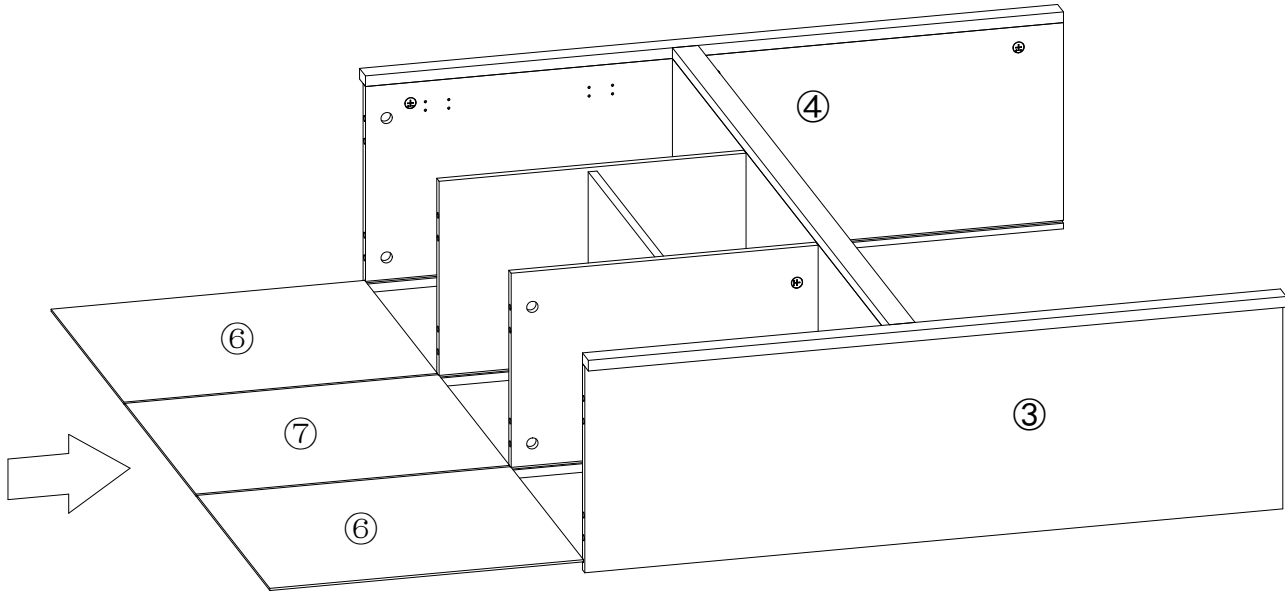

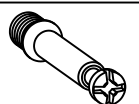
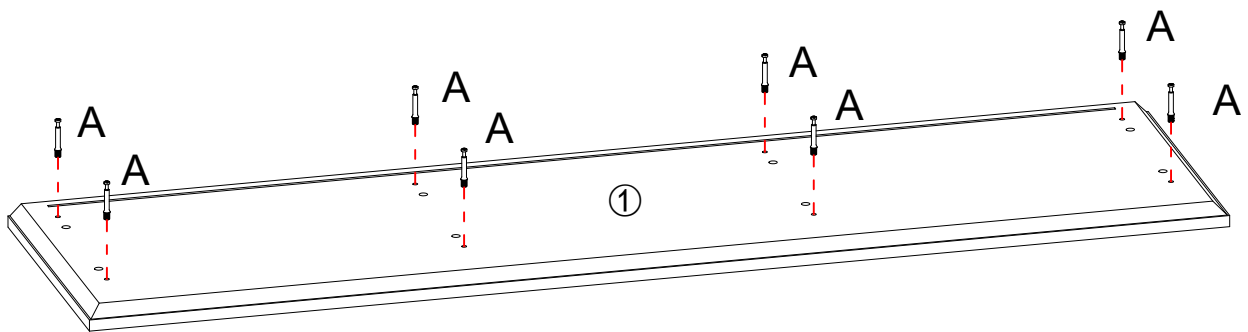

26.

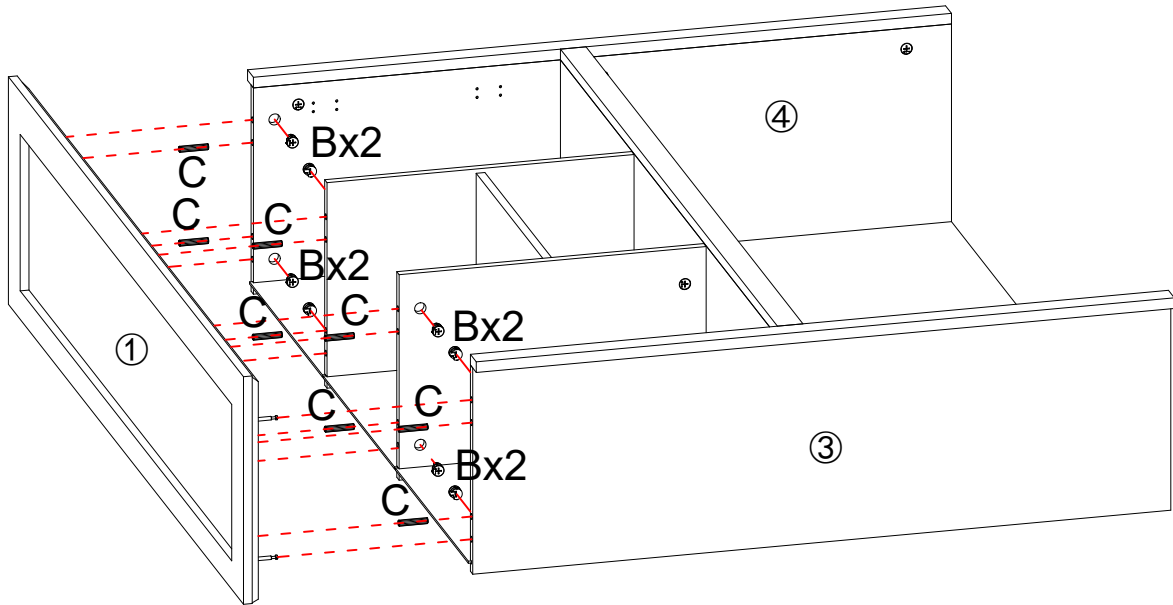

A x 8pcs

27.



	
B x 8 pcs	C x 8 pcs

28.

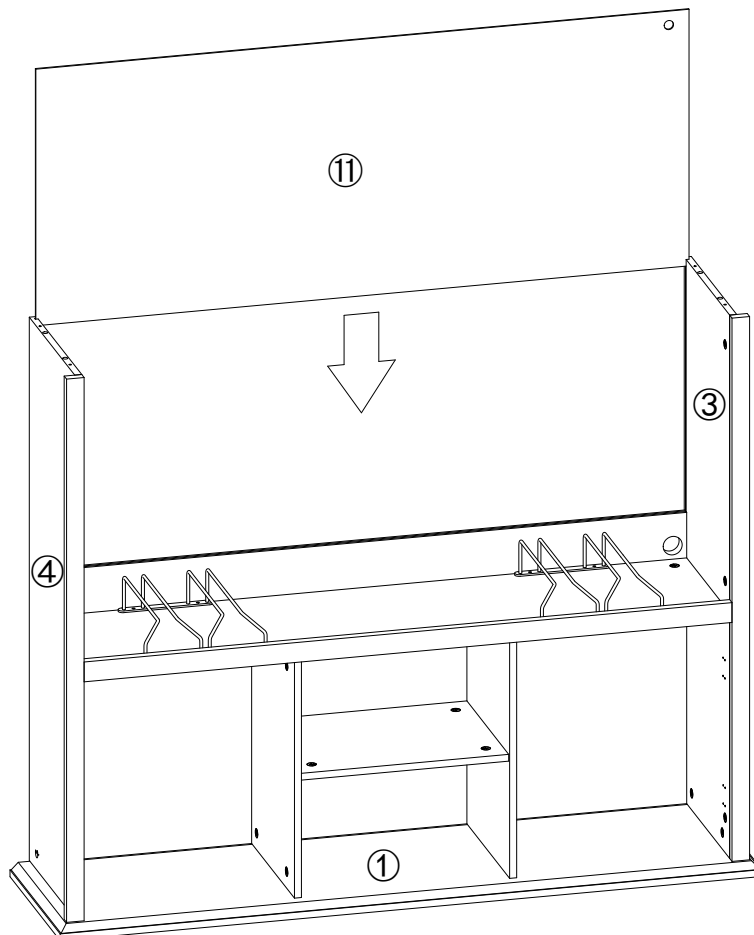

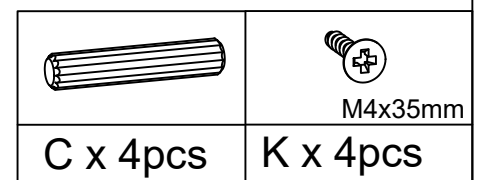
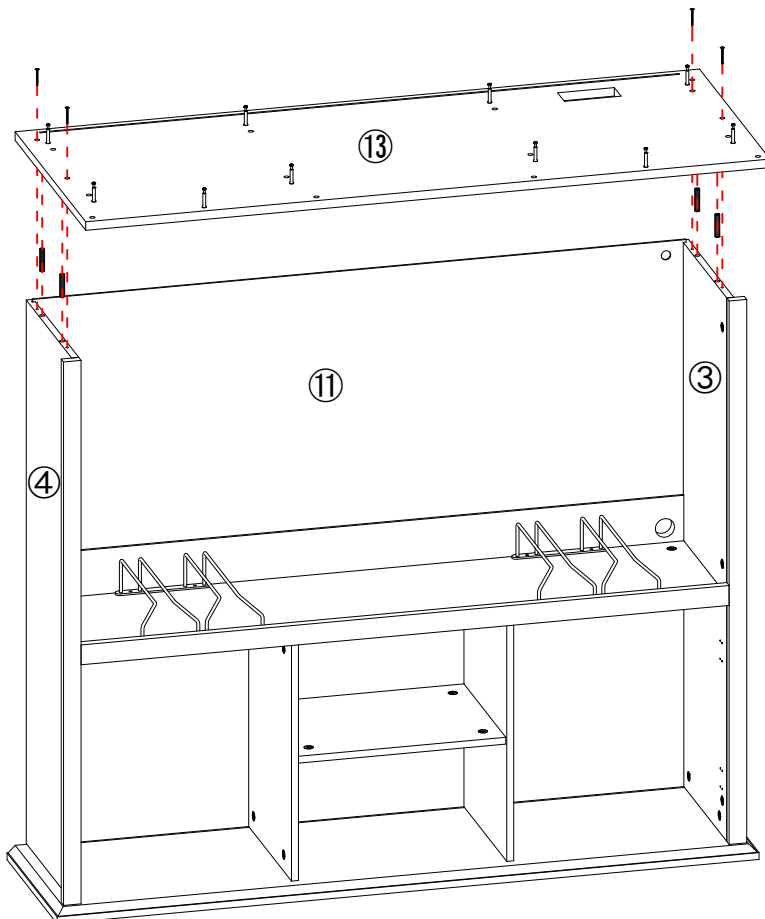
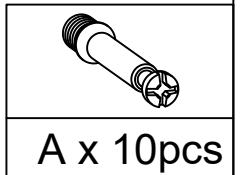
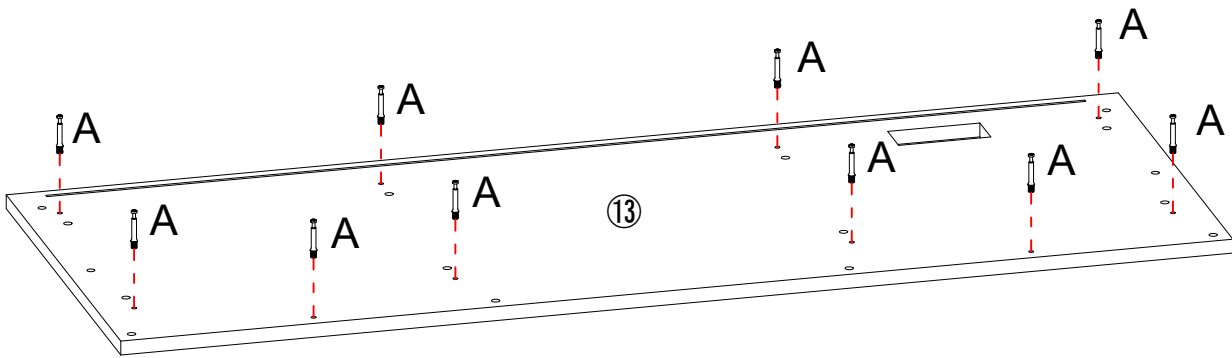

29.

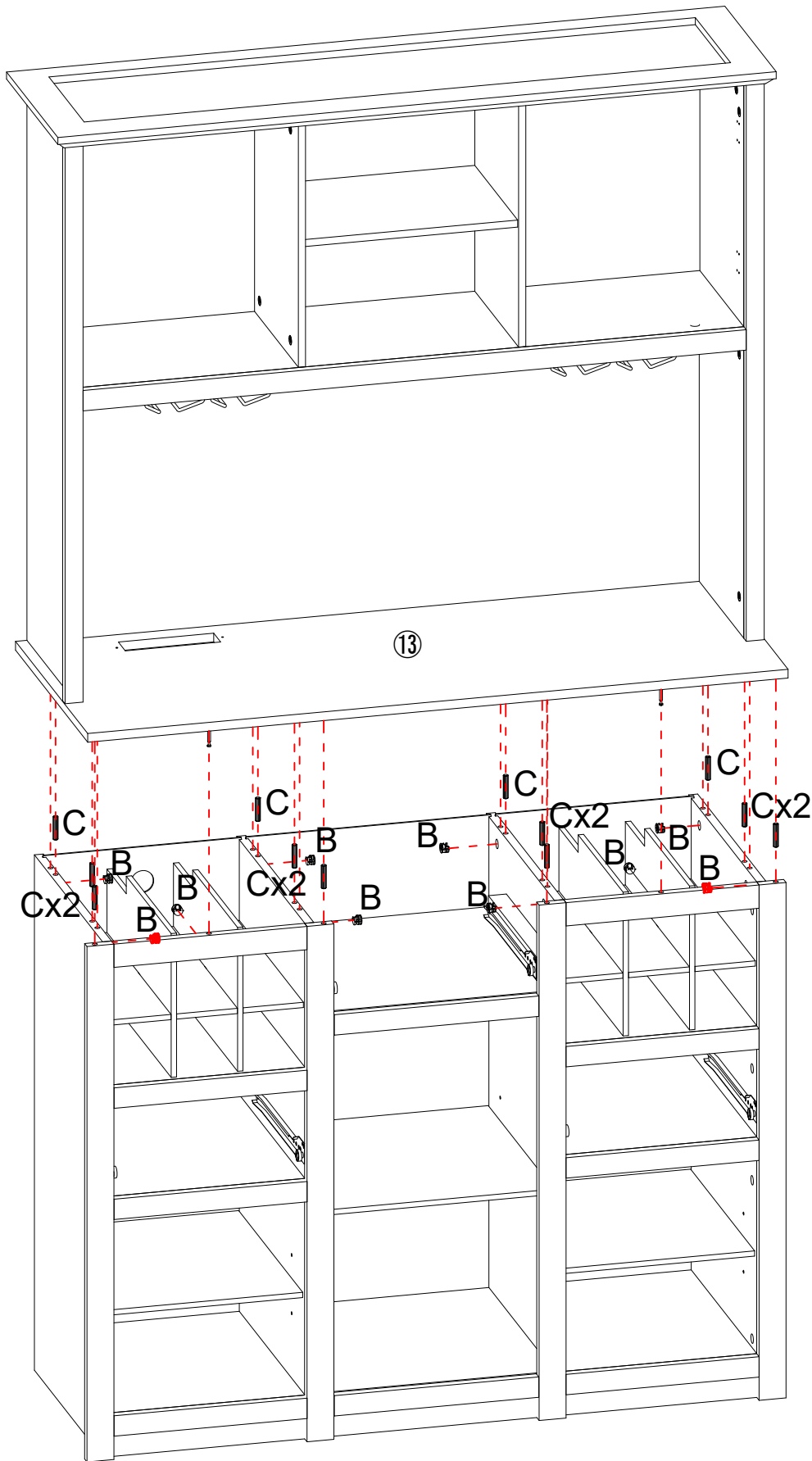

30.



	
B x10pcs	C x 12pcs

31.

After removing the film from the back of the accessory T light strip, attach it to the bottom of component 0. Then, thread the T connector through the back panel 13 and pull it back to the desktop, where it should be inserted into accessory P.

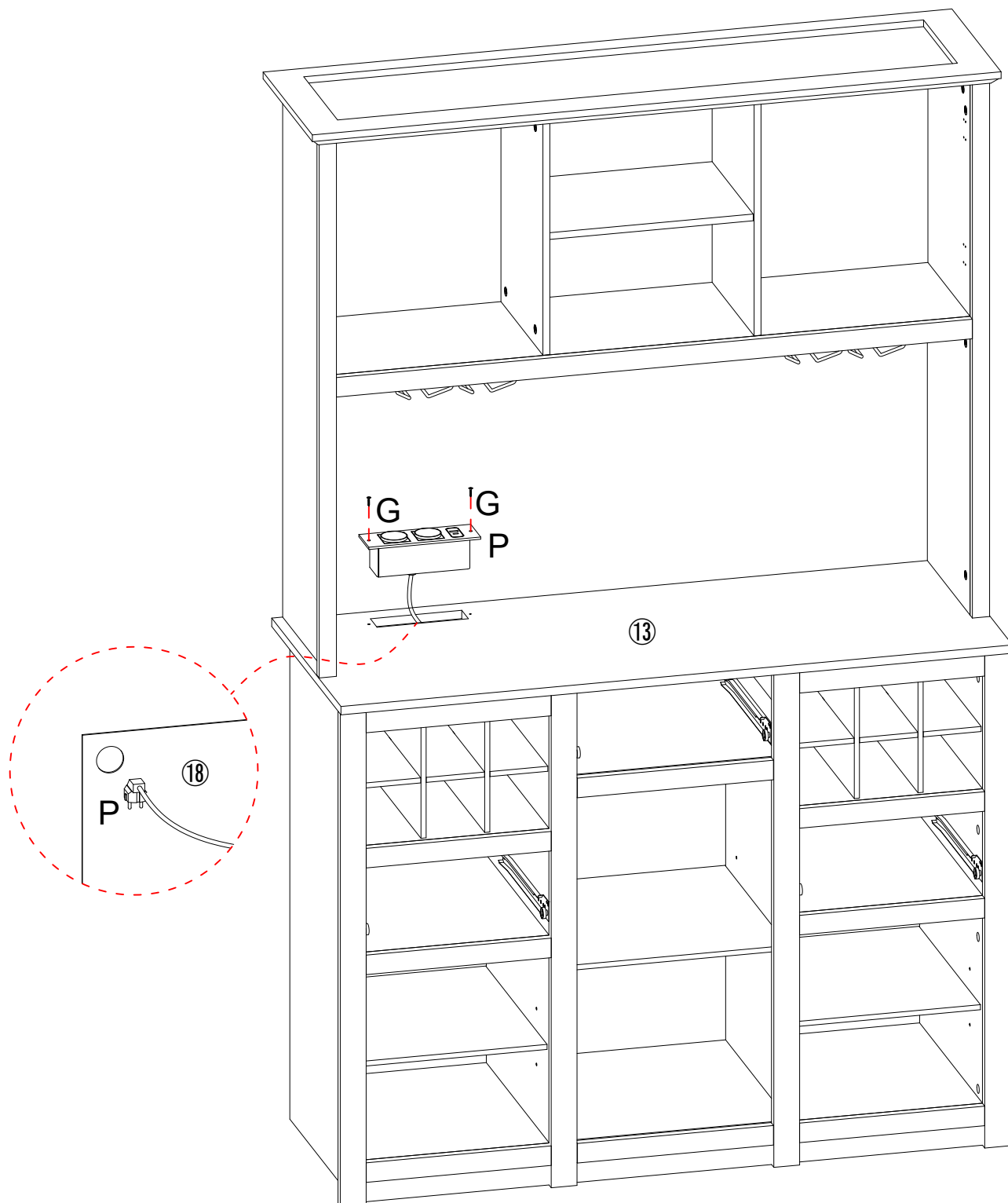

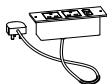
 M3x16mm	
G x2pcs	P x1pc

32.

DE:Nachdem Sie die Folie von der Rückseite des Zubehör-T-Lichtstreifen entfernt haben, kleben Sie sie an der Unterseite des Bauteils ②. Dann ziehen Sie das T-förmige Stromkabel durch das Teil ⑩ und wieder durch die Rückplatte ⑪, um es zurück auf den Schreibtisch zu ziehen, wo es in das Zubehör P eingesetzt werden sollte.

UK:After tearing off the film from the back of the accessory T light strip, stick it to the bottom of the component ② Then, thread the T-shaped power cord through component ⑩ and through the back panel ⑪ again to pull it back to the desktop, where it should be inserted into accessory P.

FR:Après avoir arraché le film de l'arrière de la barre de lampe t de l'accessoire, collez - le sur le fond de l'assemblage ②. Ensuite, tirez le cordon d'alimentation en forme de t à travers le composant ⑩ et à nouveau à travers la plaque arrière ⑪ pour le ramener sur le Bureau, où il doit être inséré dans le raccord p.

IT:Dopo aver strappato la pellicola dalla parte posteriore della barra T dell'accessorio, incollarla sulla parte inferiore del componente ②. Quindi trasmettere il cavo di alimentazione a forma di T attraverso il componente ⑩ e nuovamente attraverso la piastra posteriore ⑪ per tirarlo indietro sul desktop, dove dovrebbe essere inserito nell'accessorio P.

ES:Después de arrancar la película de la parte posterior de la tira de luz t del accesorio, pegarla en la parte inferior del componente ②. A continuación, el cable de alimentación en forma de t pasa por el componente ⑩ y vuelve a pasar por la placa trasera ⑪ para retirarlo a la mesa, donde debe insertarse en el accesorio p.

NL:Na het scheuren van de film van de achterkant van de T-lamp van het accessoire, plak deze aan de onderkant van het onderdeel ②. Trek vervolgens de T-vormige voedingskabel door onderdeel ⑩ en opnieuw door de achterkant ⑪ om deze terug te trekken naar het bureaublad, waar het in accessoire P moet worden geplaatst.

SE:Efter att ha slitit av filmen från tillbehör T-lampa band baksidan, klistra den på komponentens botten ②. Dra sedan den T-formade strömledningen genom komponenten ⑩ och igen genom bakplattan ⑪ för att dra den tillbaka till skrivbordet, där den bör sättas in i tillbehör P.

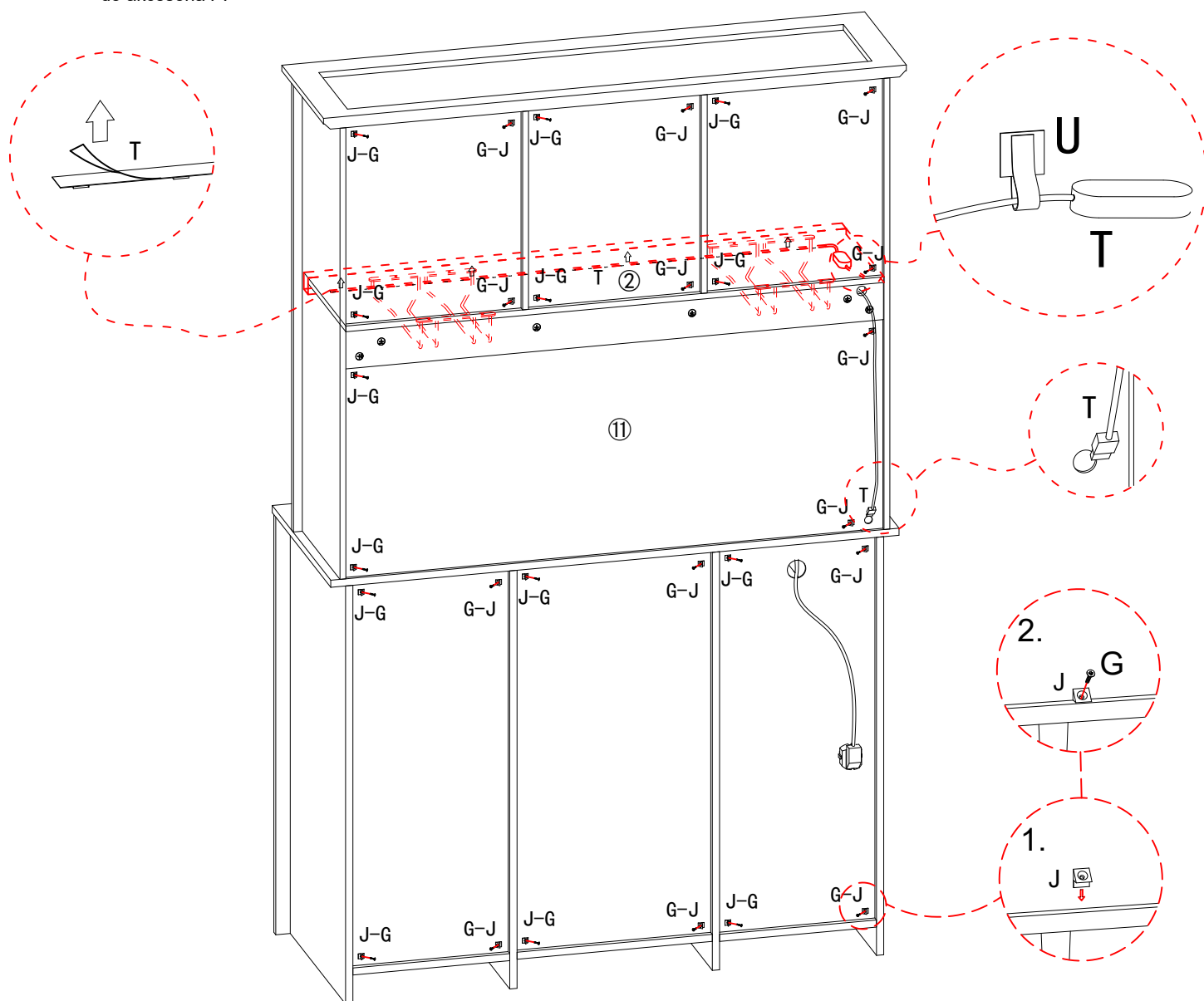

PL:Po oderwaniu folii z tyłu paska T akcesoriów, umieść ją na dole komponentu ②. Następnie przewód zasilania w kształcie T przechodzi przez część ⑩ i ponownie przez tylną płytę ⑪, aby wyciągnąć go z powrotem do pulpitu, gdzie powinien być podłączony do akcesoria P.



J x28pcs	M3x16mm G x28pcs	T x1pc	U x1pc

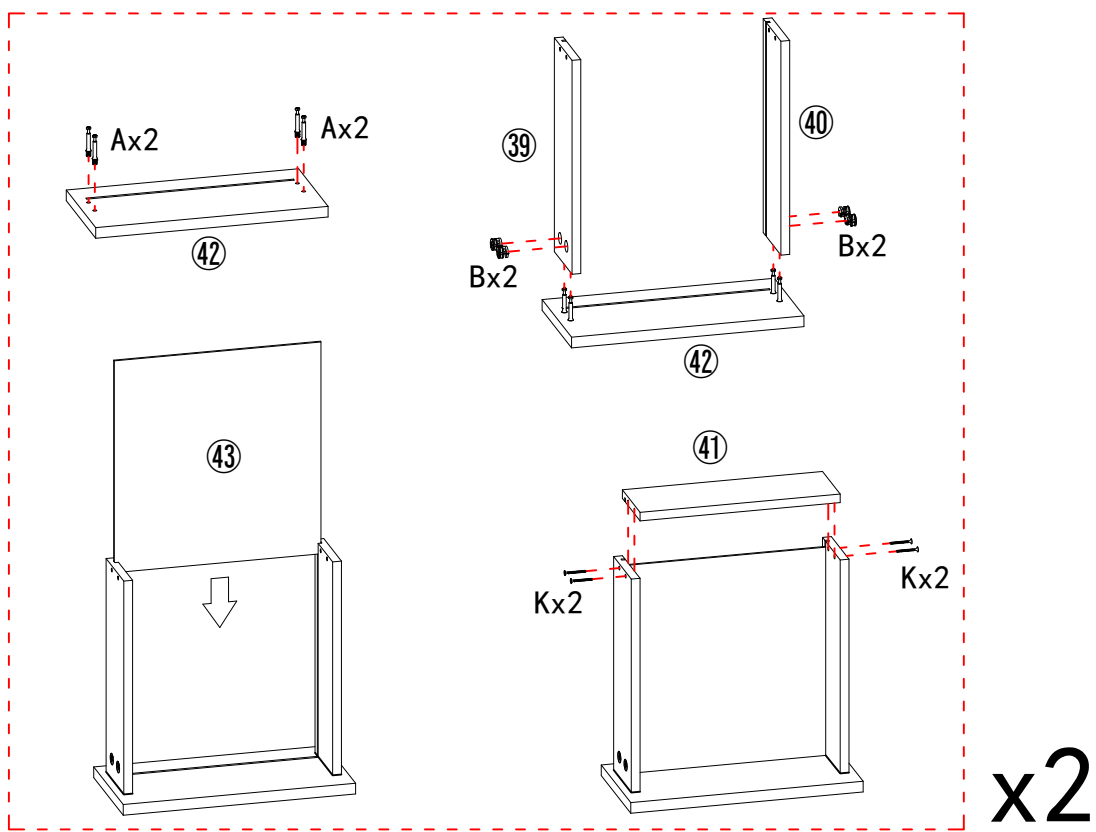

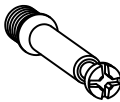
33.

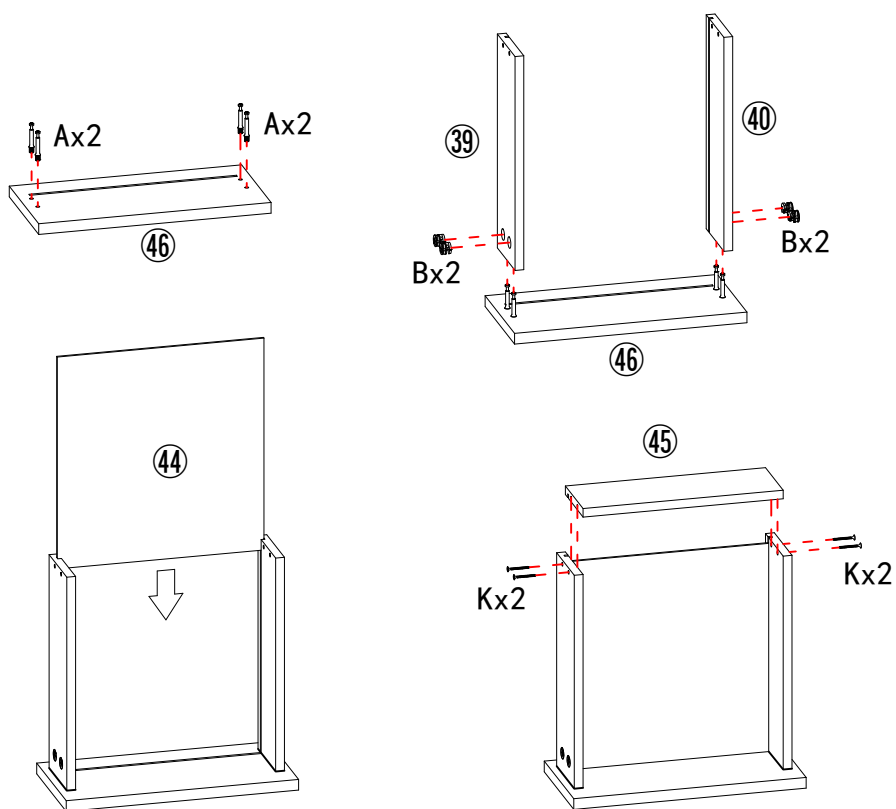

		 M4x35mm
A x8pcs	B x8pcs	K x8pcs

34.





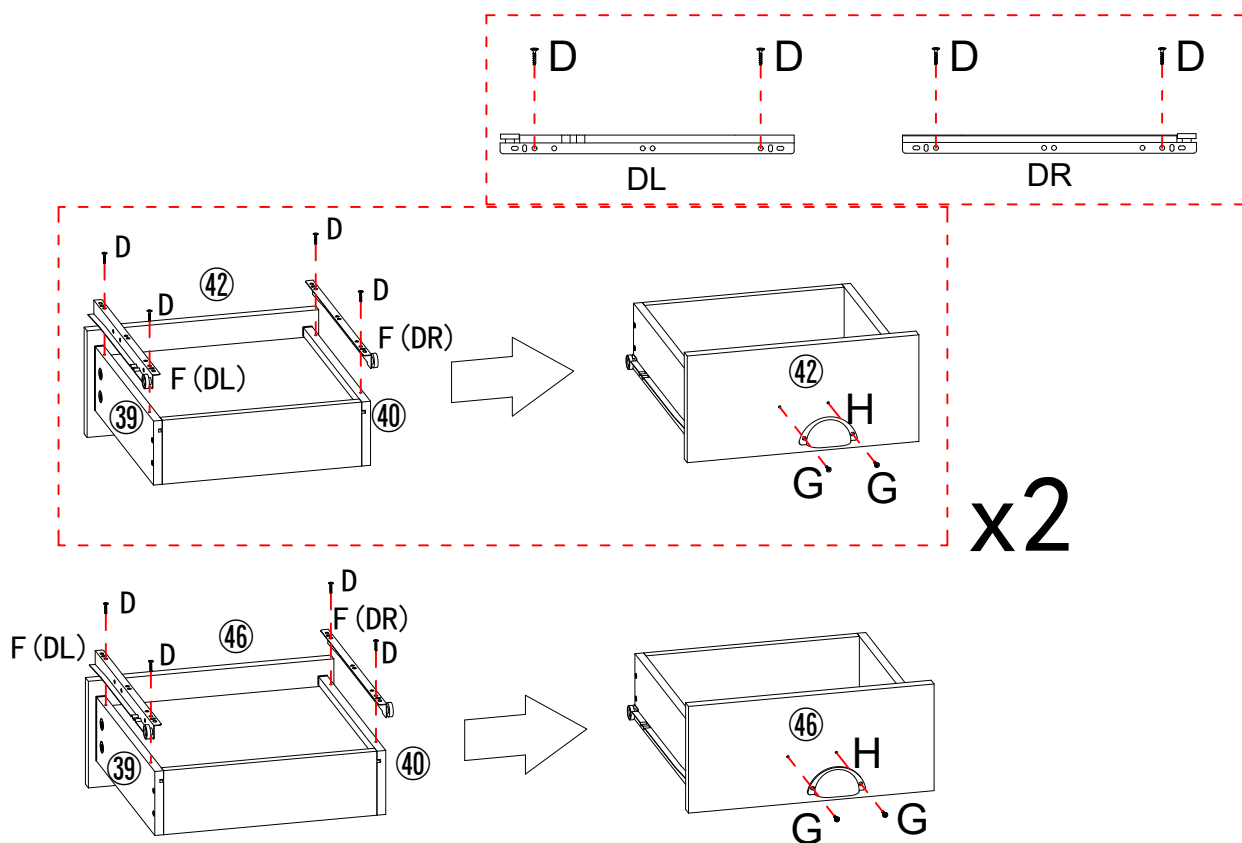

		 M4x35mm
A x4pcs	B x4pcs	K x4pcs

35.



x2

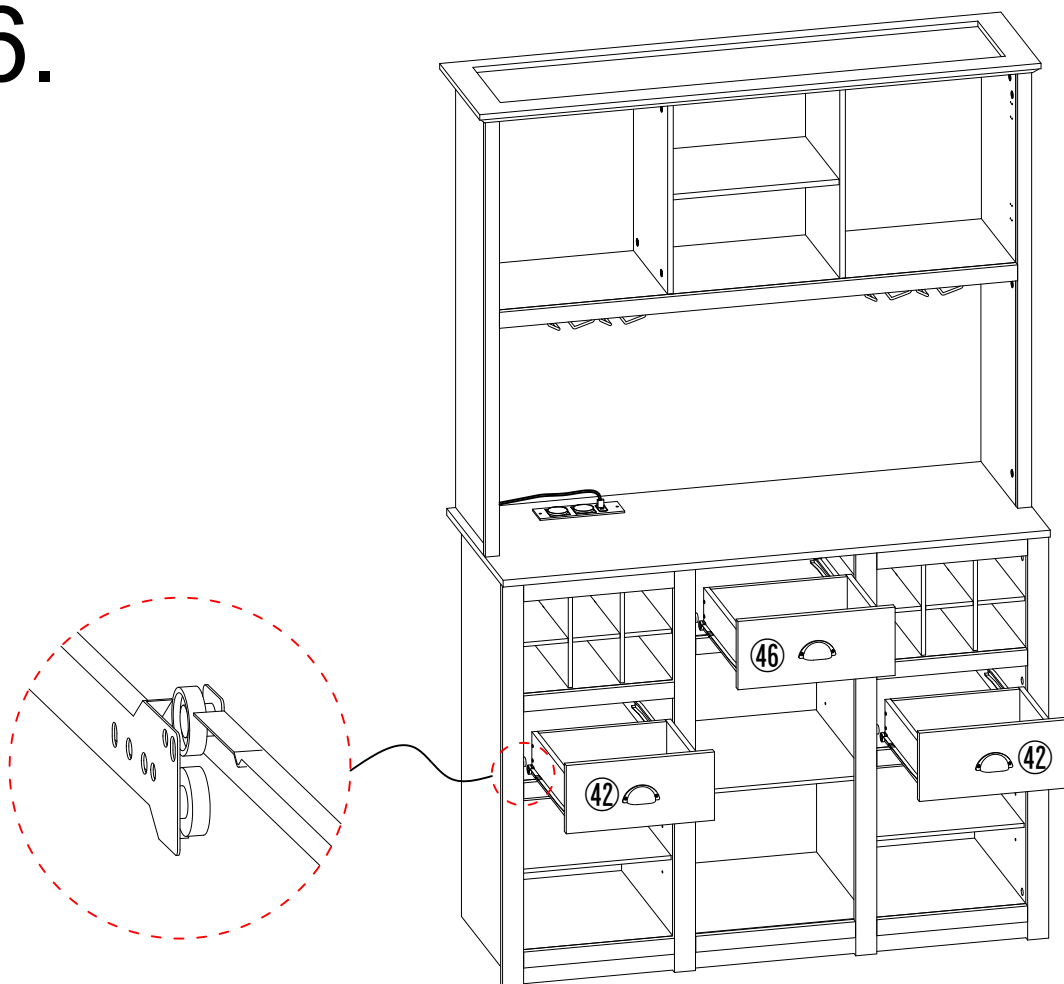

 M3x12mm	 DRx3 DLx3	 M3x16mm	
D x 12pcs	F	G x 6pcs	H x 3pcs

36.



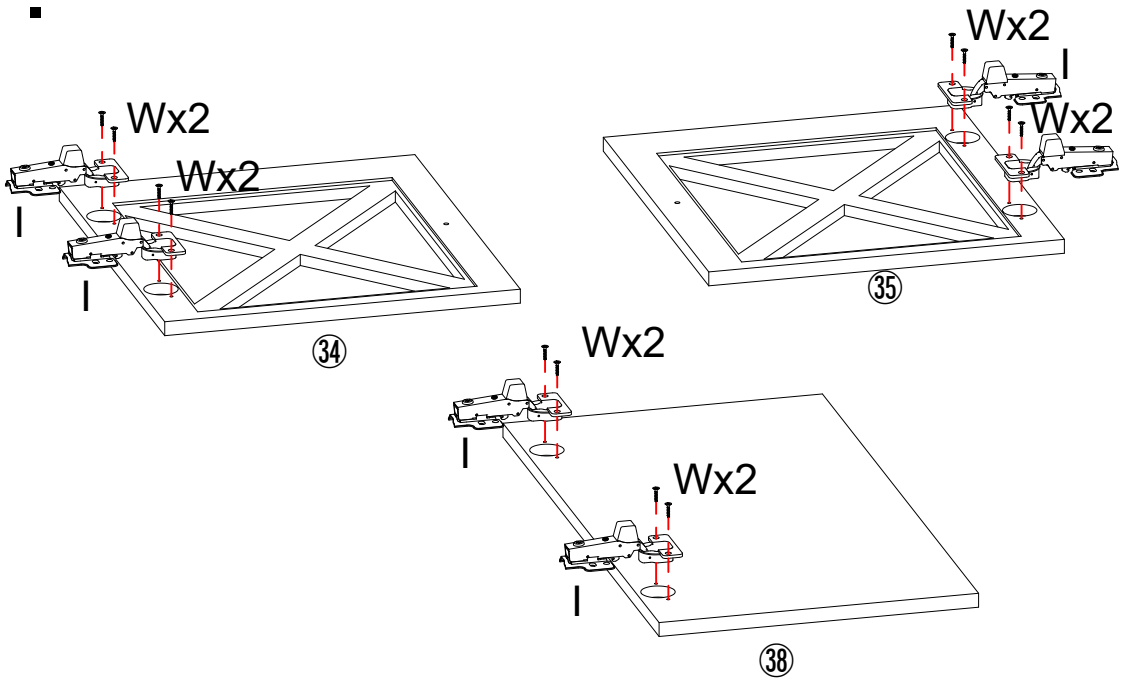



37.

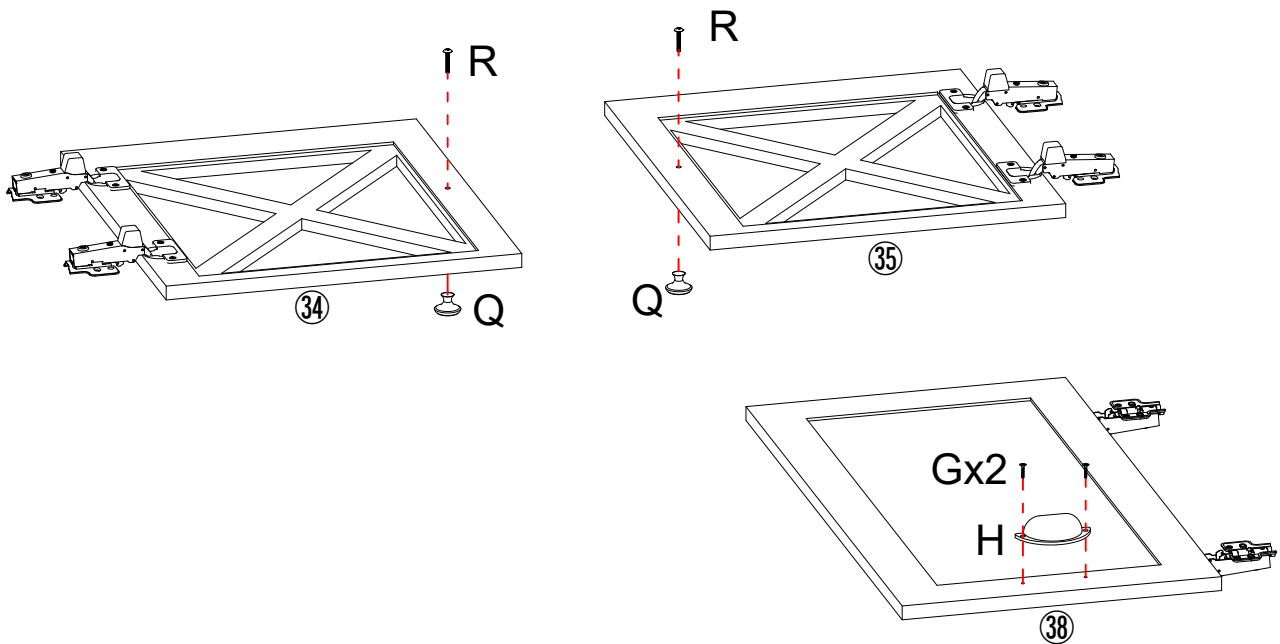

	
I x6pcs	M4x14mm
	W x12pcs

38.



			
M4x14mm		M4x22mm	
G x2pcs	Q x 2pcs	R x 2pcs	H x1pc

39.

1 Sideways / Tilt adjustment

Turn the screw
clockwise to move the door further away from
 the side of the cabinet
anticlockwise to move the door closer to the
 side of the cabinet

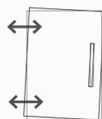

2 4 Height adjustment

While supporting the weight of the door, turn the
 screws
clockwise to move the door up
anticlockwise to move the door down

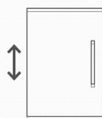

3 Forward and back adjustment



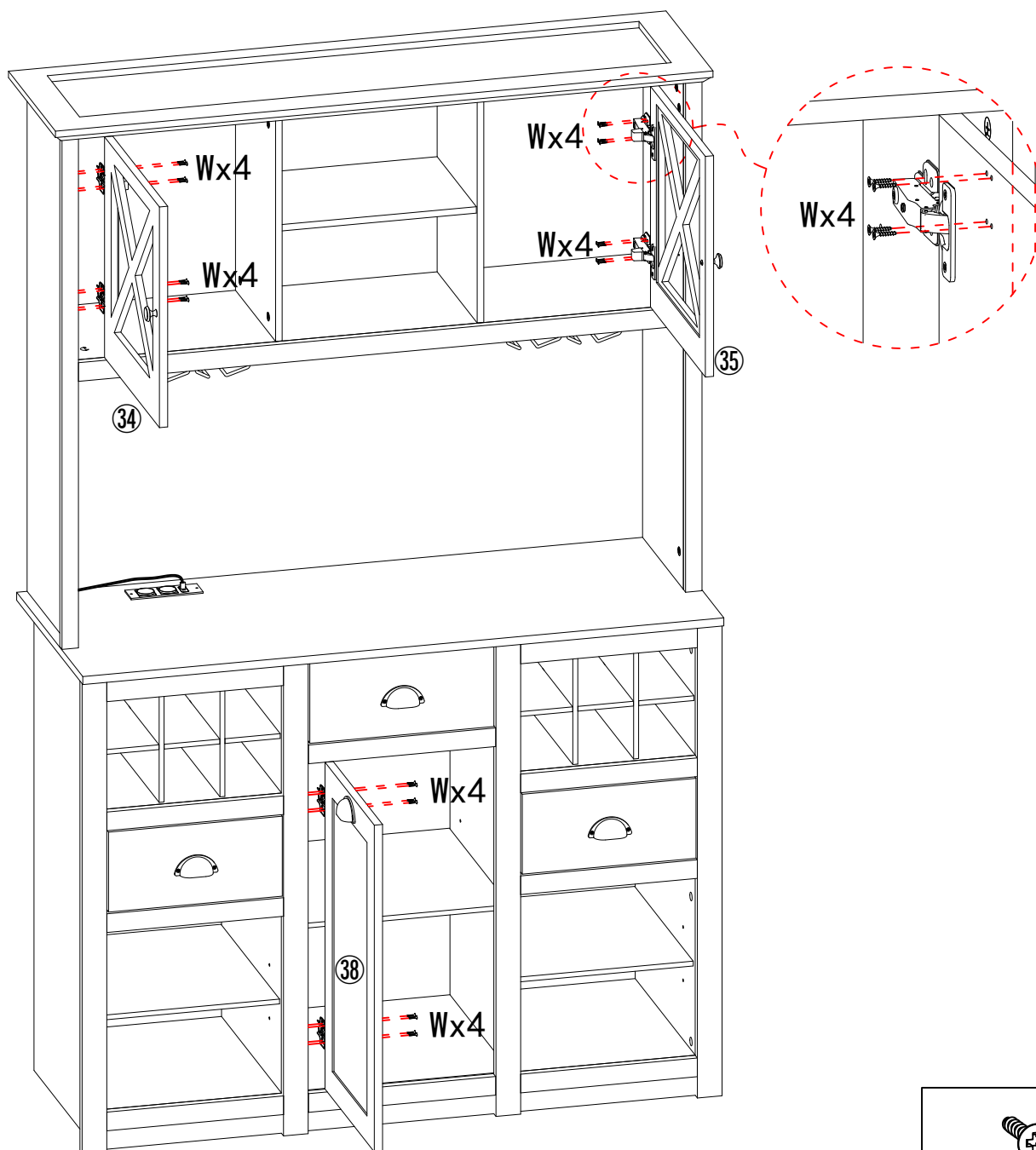
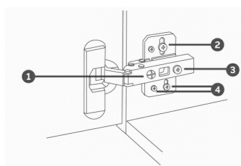

If the gap between the back of the door and the
 cabinet is too small, and the door may not close
 fully. Turn the screw
clockwise to decrease the gap between the
 door and the cabinet
anticlockwise to increase the gap between the
 door and the cabinet



M4x14mm

W x24pcs

40.

	 M4x35mm
L x 2pcs	M x 2pcs
 M4x16mm	
N x 2pcs	O x 2pcs

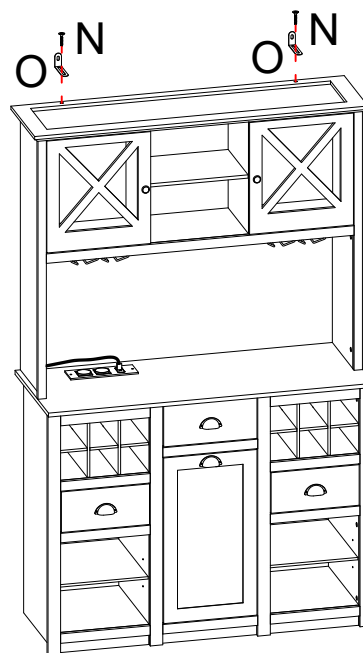

41.

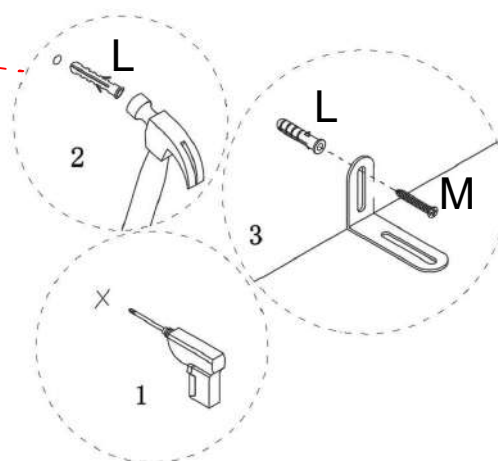
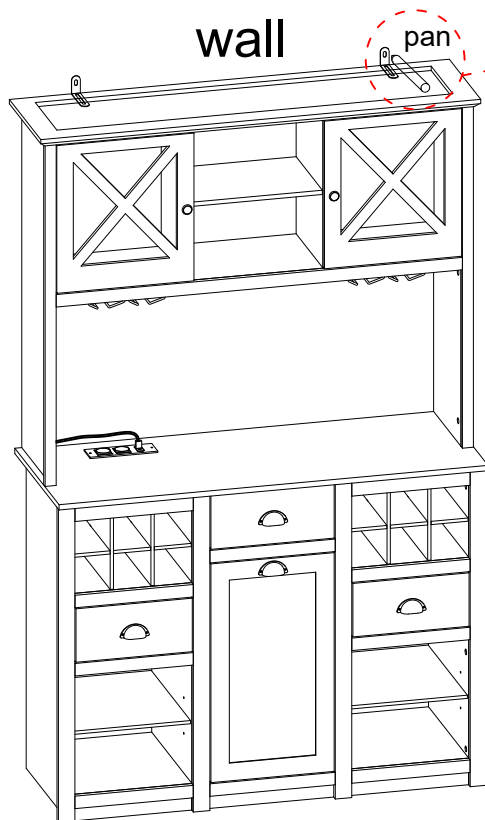

DE:ACHTUNG: Zur Sicherheit und Stabilität empfehlen wir Ihnen, die Kippsicherungszubehör an der Wand zu befestigen, um ein Umkippen, Verletzungen und Sachschäden zu verhindern.

UK:ATTENTION: For safety and stability, we suggest you have to secure the anti tip accessories to the wall to prevent tipping, injury, and property damage.

FR:ATTENTION : Pour la sécurité et la stabilité, nous vous recommandons de fixer les accessoires anti-basculement au mur afin d'éviter tout renversement, blessure et dommage matériel.

IT:ATTENZIONE: Per garantire sicurezza e stabilità, ti consigliamo di fissare gli accessori di sicurezza contro il ribaltamento alla parete, per prevenire ribaltamenti, lesioni e danni materiali.

ES:ATENCIÓN: Para garantizar seguridad y estabilidad, le recomendamos que fije los accesorios de seguridad contra el vuelco a la pared para prevenir vuelcos, lesiones y daños materiales.

NL:LET OP: Voor veiligheid en stabiliteit raden wij aan om de anti-kantelaccessoires aan de muur te bevestigen om kantelen, letsel en schade aan eigendommen te voorkomen.

SE:OBS: För säkerhet och stabilitet rekommenderar vi att du fäster anti-tipp-tillbehören på väggen för att förhindra att de tippar, skador och egendomsskador.

PL:UWAGA: Dla bezpieczeństwa i stabilności zalecamy przymocowanie akcesoriów antyprzewrócenia do ściany, aby zapobiec przewróceniu, urazom i uszkodzeniu mienia.

42.



Z x 24pcs

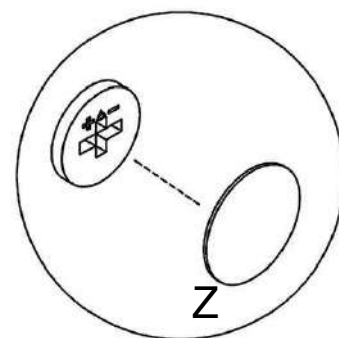
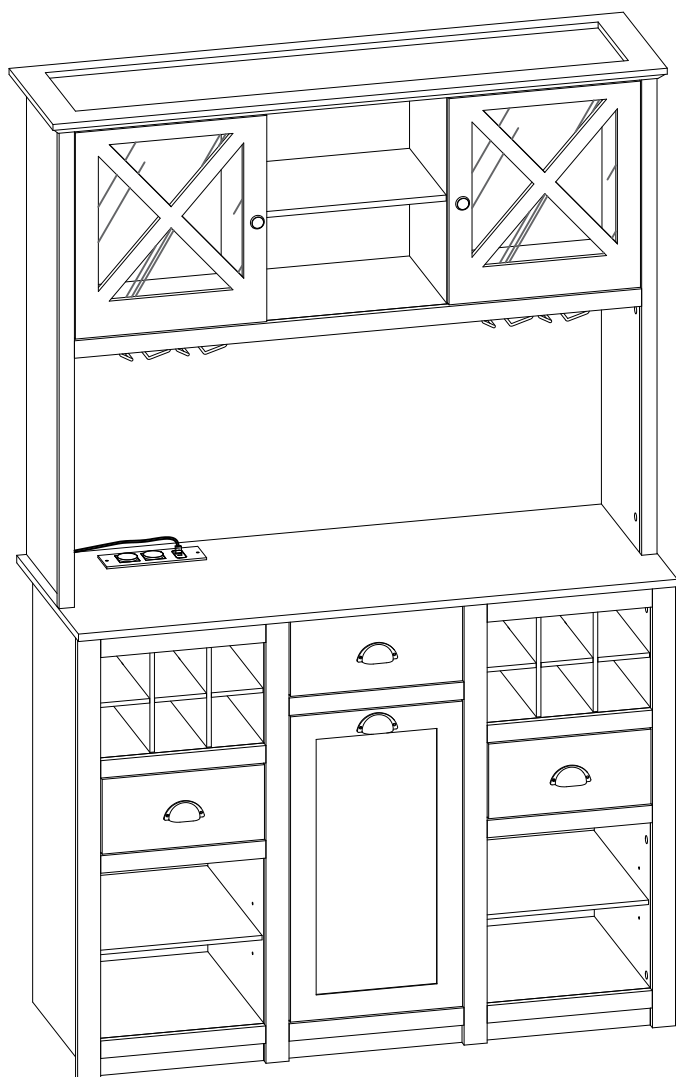

EN:In order to make the product more beautiful,please paste hardware H on the exposed holes.

DE:Um das Produkt noch schöner zu machen, kleben Sie bitte Hardware H auf die freiliegenden Löcher.

FR:Afin de rendre le produit plus beau, s' il vous plaît coller le matériel H sur les trous exposés.

IT:Per rendere il prodotto più bello,incollare l'hardware H sui fori esposti.

ES:Con el fin de hacer el producto más hermoso, por favor pega hardware H en los agujeros expuestos.



Verification of Compliance

Verification No.: MK25050138P01-S01

Name and address of Applicant:

Dongguan Jingdeli Intelligent Technology Co.,Ltd.
Room 202, Building 3, No.28, Dongkeng Town Yanhe West 1st Road, Dongkeng Town, Dongguan, 523000, Guangdong, China

Name and address of Manufacturer:

Dongguan Jingdeli Intelligent Technology Co.,Ltd.
Room 202, Building 3, No.28, Dongkeng Town Yanhe West 1st Road, Dongkeng Town, Dongguan, 523000, Guangdong, China

Product name: **Furniture Power Distribution Unit**

Rated: Input: 100-240VAC, 50/60Hz, Max.16A; 2*USB Output: DC 5V, 2A

JDLO22PH,

Product model(s): JDLO followed by 1-6, followed by T or P, followed by S or H, maybe followed by K, maybe followed by U, D or A

Product trademark: **JNDELY**

This Verification confirms that the product meets the requirements of the following standard.

The conformity was demonstrated based on following standard(s) listed by European Commission as harmonized with LVD Directive 2014/35/EU.

EN IEC 62368-1:2024+A11:2024

IEC 60884-1:2002+A1:2006+A2:2013

The Verification has been carried out in accordance with individual rules and conditions agreed with the applicant. Evaluation has been carried out in accordance with:

Test report(s) No.: MK25050138P01-S01

Test conducted by: TMC Testing Services (Shenzhen) Co., Ltd.

Verification issue date: May 30, 2025

Notes:

This Verification refers to the above mentioned product and its conformity in regards of above mentioned standard(s) was proven on test sample.

This Verification does not imply meeting all essential requirements, assessment of the series-production or any other restricted Notified Bodies conformity assessment procedure appropriate for the product.

This Verification holder shall use this Verification in connection to Verification of conformity and technical data relevant for the product the Verification was issued.

TMC Testing Services (Shenzhen) Co., Ltd.

t:86-755-86642861 cert@tmc-lab.com www.tmc-lab.com

1/F. of Building A1, 5/F. of Building B1, & 1/F. of Building A3, Xinshidai Gongrong Industrial Park, No.2, Shihuan Road, Shilong Community, Shiyuan Subdistrict, Bao'an District, Shenzhen, Guangdong, China



Gold T and

Lab Director
Dodd Tang

TMC

Importeur	Decobus Handel GmbH
Adresse	Innungsstraße 9, 21244 Buchholz, Deutschland
URL	https://www.decobusgroup.de
Hersteller	Dongguan Jingdeli Intelligent Technology Co.,Ltd.
Adresse	Room 202, Building 3, No.28, Dongkeng Town Yanhe West 1st Road.Dongkeng Town,Dongguan, 523000,Guangdong, China
URL/Email	1635502564@qq.com
Produktionsdatum	2025/12
Hergestellt In	China
	Decobus Handel GmbH Innungsstraße 9, 21244 Buchholz,Deutschland https://www.decobusgroup.de
 	Product: Furniture Power Distribution Unit Modell: JDLO22PH Nennspannung: 13A Nennfrequenz: 230V Leistung: 2990W

Verification of Compliance

Verification No.: MK25050138P01-E01

Name and address of Applicant:
Dongguan Jingdell Intelligent Technology Co., Ltd.
Room 202, Building 3, No.28, Dongkeng Town Yanhe West 1st Road, Dongkeng Town, Dongguan, 523000, Guangdong, China

Name and address of Manufacturer:
Dongguan Jingdell Intelligent Technology Co., Ltd.
Room 202, Building 3, No.28, Dongkeng Town Yanhe West 1st Road, Dongkeng Town, Dongguan, 523000, Guangdong, China

Product name:
Furniture Power Distribution Unit

Rated:
110-240VAC, 60Hz

Product model(s):
JDLO22PH, JDLO followed by 1-6, followed by T or P, followed by S or H, maybe followed by K, maybe followed by U, D or A

JNDELY

This verification confirms that the product meets the requirements of the following standard.
The conformity was demonstrated based on following standard(s) listed by European Commission as harmonized with EMC Directive 2014/30/EU

EN 55032:2015+A11:2020	EN 55035:2017+A11:2020
EN IEC 61000-3-2:2019+A1:2021	EN 61000-3-3:2013/A2:2021

The verification has been carried out in accordance with individual rules and conditions agreed with the applicant. Evaluation has been carried out in accordance with:

Test report(s) No.: MK25050138P01-E01

Test conducted by: TMC Testing Services (Shenzhen) Co., Ltd.

Verification issue date: May 29, 2025

Notes:
This verification refers to the above mentioned product and its conformity in regards of above mentioned standard(s) was proven on test sample.
This verification does not imply meeting all essential requirements, assessment of the series-production or any other restricted Notified Bodies conformity assessment procedure appropriate for the product.
This verification holder shall use this verification in connection to verification of conformity and technical data relevant for the product the verification was issued.

TMC Testing Services (Shenzhen) Co., Ltd.
t:86-755-86642861 cert@tmc-lab.com www.tmc-lab.com
1st Floor, Block A1, Zone A, Xinshidai Gongrong Industrial Park, No. 2, Shihuan Road, Shiyuan Street, Baoan District, Shenzhen, China



Verification of Compliance

Verification No.: MK25050138P01-C01

Name and address of Applicant:
Dongguan Jingdell Intelligent Technology Co., Ltd.
Room 202, Building 3, No.28, Dongkeng Town Yanhe West 1st Road, Dongkeng Town, Dongguan, 523000, Guangdong, China

Name and address of Manufacturer:
Dongguan Jingdell Intelligent Technology Co., Ltd.
Room 202, Building 3, No.28, Dongkeng Town Yanhe West 1st Road, Dongkeng Town, Dongguan, 523000, Guangdong, China

Product name:
Furniture Power Distribution Unit

Product model(s):
JDLO22PH, JDLO followed by 1-6, followed by T or P, followed by S or H, maybe followed by K, maybe followed by U, D or A; JDLY followed by 1-6, followed by 1-6, followed by T or P, followed by S or H, maybe followed by K, maybe followed by U, D or A

JNDELY

This verification confirms that the product meets the requirements of the following standard.
The conformity was demonstrated based on following standard(s) listed by European Commission as harmonized with Directive RoHS 2.0 Directive (EU) 2015/863 and (EU)2017/2102 amending Annex II to Directive 2011/65/EU

IEC 62321-1:2013	IEC 62321-3-1:2013
IEC 62321-4:2013/AMD1:2017	IEC 62321-5:2013
IEC 62321-6:2015	IEC 62321-7-1:2015
IEC 62321-7-2:2017	IEC 62321-8:2017
IEC 62321-2:2021	

The verification has been carried out in accordance with individual rules and conditions agreed with the applicant. Evaluation has been carried out in accordance with:

Test report(s) No.: MK25050138P01-C01

Test conducted by: TMC Testing Services (Shenzhen) Co., Ltd.

Verification issue date: May 29, 2025

Notes:
This verification refers to the above mentioned product and its conformity in regards of above mentioned standard(s) was proven on test sample.
This verification does not imply meeting all essential requirements, assessment of the series-production or any other restricted Notified Bodies conformity assessment procedure appropriate for the product.
This verification holder shall use this verification in connection to verification of conformity and technical data relevant for the product the verification was issued.

TMC Testing Services (Shenzhen) Co., Ltd.
t:86-755-86642861 cert@tmc-lab.com www.tmc-lab.com
1st Floor, Block A1, Zone A, Xinshidai Gongrong Industrial Park, No. 2, Shihuan Road, Shiyuan Street, Baoan District, Shenzhen, China





This certificate is responsible for testing sample only.
Please refer to this corresponding test report to get testing process and data.

CERTIFICATE

ATTESTATION Certificate of Compliance

Technical file of the company mentioned below has been inspected and audit has been completed successfully

The Low Voltage Directive 2014/35/EU has been taken as references for these processes.

Certificate's Holder : Shenzhen zhengxin Optoelectronics Technology Co., Ltd
 Address : 7th Floor, Building A9, Xinghuaxiong Science and Technology Park, Baihua Community, Guangming New District, Shenzhen, China
 Manufacturer : Shenzhen zhengxin Optoelectronics Technology Co., Ltd
 Address : 7th Floor, Building A9, Xinghuaxiong Science and Technology Park, Baihua Community, Guangming New District, Shenzhen, China
 Product Name : 5050 RGB 5M light strip
 Product Model (S) : ZX5050-60LED/M-RGB-5V-24Key, ZX5050-30LED/M-RGB-5V-24Key, ZX5050-72LED/M-RGB-5V-24Key, ZX5050-84LED/M-RGB-5V-24Key
 Trade Mark : N/A
 Related Directive : 2014/35/EU
 Related Standards : EN IEC 60598-2-1:2021
 EN IEC 60598-1:2021 + AMD11:2022



Jason
Certification Manager

Certificate Number : HK2509102828S
 Report No. : HK2509102828-SR
 Registration Date : Nov. 07, 2025

The information of the certificate can be checked through <https://www.huak.com>. The CE mark which is shown on the certificate can only be used under the conditions that the products complete with all of the relevant Directives of CE Declaration of Conformity. The Manufacturer should be responsible for the internal production control so that the products complied with the essential requirements of the above mentioned Directive(s). Certificate holder must notify all changes to the original certification laboratory of HUAK.



Importeur	Decobus Handel GmbH
Adresse	Innungsstraße 9, 21244 Buchholz, Deutschland
URL	https://www.decobusgroup.de
Hersteller	Shenzhen zhengxin Optoelectronics Technology Co.,Ltd
Adresse	7th Floor,Building A9,Xinghuaxiong Science and Technology Park, Baihua Community,Guangming New District,Shenzhen,China
URL/Email	1635502564@qq.com
Productiondatum	2025/12
Hergestellt In China	
	Decobus Handel GmbH Innungsstraße 9, 21244 Buchholz,Deutschland https://www.decobusgroup.de
	Product: 5050 RGB 5M light strip Modell: 5050-60D-RGB-10MM-5V Nennspannung: 5V Nennfrequenz: 50-60HZ Leistung: 2A



This certificate is responsible for testing sample only.
Please refer to this corresponding test report to get testing process and data.

CERTIFICATE

ATTESTATION Certificate of Compliance

Technical file of the company mentioned below has been inspected and audit has been completed successfully.
The RED Directive 2014/53/EU has been taken as references for these processes.

Certificate's Holder : Shenzhen zhengxin Optoelectronics Technology Co., Ltd
Address : 7th Floor, Building A9, Xinghuaxiong Science and Technology Park, Baihua Community, Guangming New District, Shenzhen, China
Manufacturer : Shenzhen zhengxin Optoelectronics Technology Co., Ltd
Address : 7th Floor, Building A9, Xinghuaxiong Science and Technology Park, Baihua Community, Guangming New District, Shenzhen, China
Product Name : 5050 RGB 5M light strip
Product Model (S) : ZX5050-60LED/M-RGB-5V-24Key, ZX5050-12LED/M-RGB-5V-24Key, ZX5050-18LED/M-RGB-5V-24Key, ZX5050-30LED/M-RGB-5V-24Key, ZX5050-72LED/M-RGB-5V-24Key, ZX5050-84LED/M-RGB-5V-24Key
Trade Mark : N/A
Related Directive : Article 3.1(a) : EN IEC 62368-1:2024 + A11:2024
EN 62479:2010
EN 50663:2017
EN 301 489-1 V2.2.3 (2019-11)
EN 301 489-3 V2.3.2 (2023-01)
EN 301 489-17 V3.3.1 (2024-09)
EN 55032:2015 + A1:2020 + A11:2020
EN 55035:2017 + A11:2020
Article 3.1(b) :
Article 3.2) : ETSI EN 300 328 V2.2.2 (2019-07)
ETSI EN 300 440 V2.2.1 (2018-07)
Certificate Number : HK2509105177E
Report No. : HK2509105177-1SRV-2EH-1ER-2ER-3ER
Registration Date : Nov. 07, 2025



Jason
Certification Manager

The information of the certificate can be checked through <https://www.huak.com>. The CE mark which is shown on the certificate can only be used under the conditions that the products complete with all of the relevant Directives of CE Declaration of Conformity. The Manufacturer should be responsible for the internal production control so that the products complied with the essential requirements of the above mentioned Directive(s). Certificate holder must notify all changes to the original certification laboratory of HUAK.



This certificate is responsible for testing sample only.
Please refer to this corresponding test report to get testing process and data.

CERTIFICATE

ATTESTATION Certificate of Compliance

Technical file of the company mentioned below has been inspected and audit has been completed successfully.
The RoHS Directive 2015/863/EU amending Annex II to Directive 2011/65/EU has been taken as references for these processes.

Certificate's Holder : Shenzhen zhengxin Optoelectronics Technology Co., Ltd
Address : 7th Floor, Building A9, Xinghuaxiong Science and Technology Park, Baihua Community, Guangming New District, Shenzhen, China
Manufacturer : Shenzhen zhengxin Optoelectronics Technology Co., Ltd
Address : 7th Floor, Building A9, Xinghuaxiong Science and Technology Park, Baihua Community, Guangming New District, Shenzhen, China
Product Name : 5050 RGB 5M light strip
Model No.: ZX5050-60LED/M-RGB-5V-24Key, ZX5050-12LED/M-RGB-5V-24Key, ZX5050-18LED/M-RGB-5V-24Key, ZX5050-30LED/M-RGB-5V-24Key, ZX5050-72LED/M-RGB-5V-24Key, ZX5050-84LED/M-RGB-5V-24Key
Trade Mark : N/A
Related Directive : Directive 2015/863/EU amending Annex II to Directive 2011/65/EU
Directive (EU)2017/2102 amending Annex III to Directive 2011/65/EU
IEC 62321-2:2021, IEC 62321-3-1:2013,
IEC 62321-5:2013, IEC 62321-4:2013+AMD1:2017, IEC 62321-7-1:2015,
IEC 62321-7-2:2017, IEC 62321-6:2015, IEC 62321-8:2017
Test Method :
Certificate Number : HK25091010731R
Report No. : HK25091010731-1RR
Issue date : September 19, 2025



Jason
Certification Manager

The information of the certificate can be checked through www.huak.com. The CE mark which is shown on the certificate can only be used under the conditions that the products complete with all of the relevant Directives of EC Declaration of Conformity. The Manufacturer should be responsible for the internal production control so that the products complied with the essential requirements of the above mentioned Directive(s). Certificate holder must notify all changes to the original certification laboratory of HUAK.



ROHS