

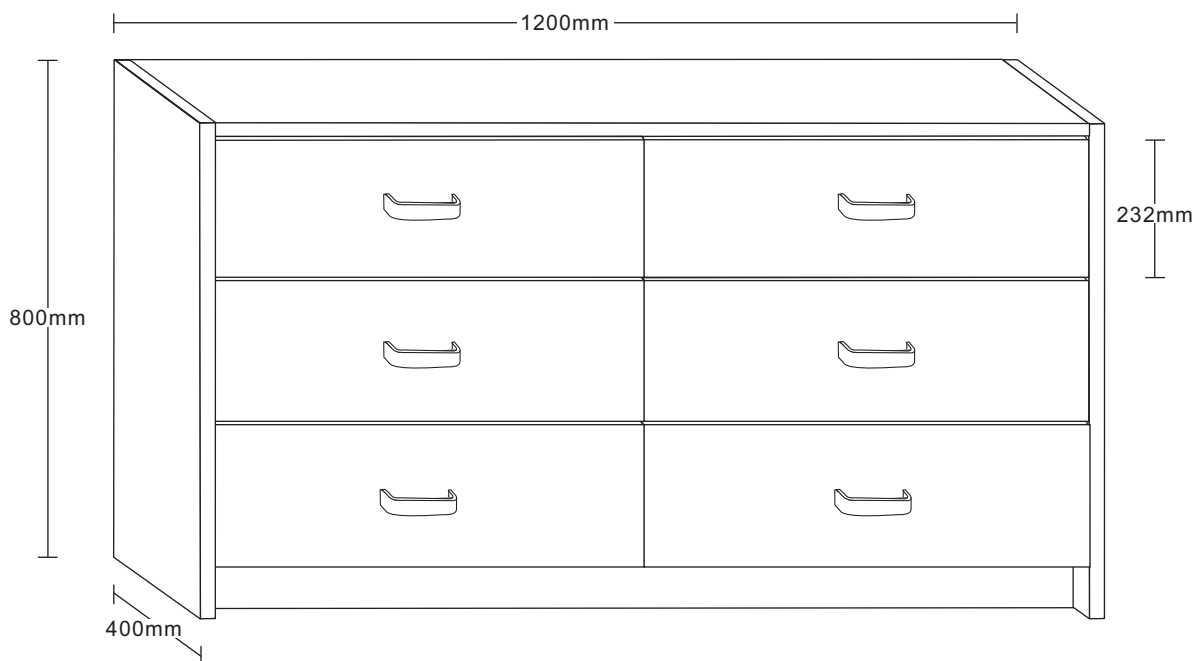

# STRATFORD 6 DRAWER WIDE CHEST

Assembly instruction- Please keep for future reference



Dimensions	No. People	Assembly Time	
Width: 120 cm		60 mins (approx)	
Depth: 40 cm			
Height: 80 cm			

Important-Please read these instructions fully before starting assembly

# ⚠ Safety and Care Advice

**Important-Please read these instructions fully before starting assembly**

- Check you have all the components and tools listed on pages 2,3 and 4.
- Remove all fittings from the plastic bags and separate them into their groups.
- Keep children and animals away from the work area, small parts could choke if swallowed.
- Make sure you have enough space to lay out the parts before starting.
- Do not stand or put weight on the product, this could cause damage.
- Assemble the item as close to its final position (in the same room) as possible.
- Assemble on a soft, level surface to avoid damaging the unit or your floor.
- We do not recommend the use of power drill/drivers for inserting screw, as this could damage the unit. only use hand screwdrivers.
- Dispose of all packaging carefully and responsibly.



## Care and Maintenance

- Only clean using a damp cloth and mild detergent, do not use bleach or abrasive cleaners.
- From time to time check that there are no loose screws on this unit.
- This product should not be discarded with household waste. Take to your local authority waste disposal centre.

If you are unhappy with the product and wish to return it, please following the retailer's returns procedure.

## Components - Panels

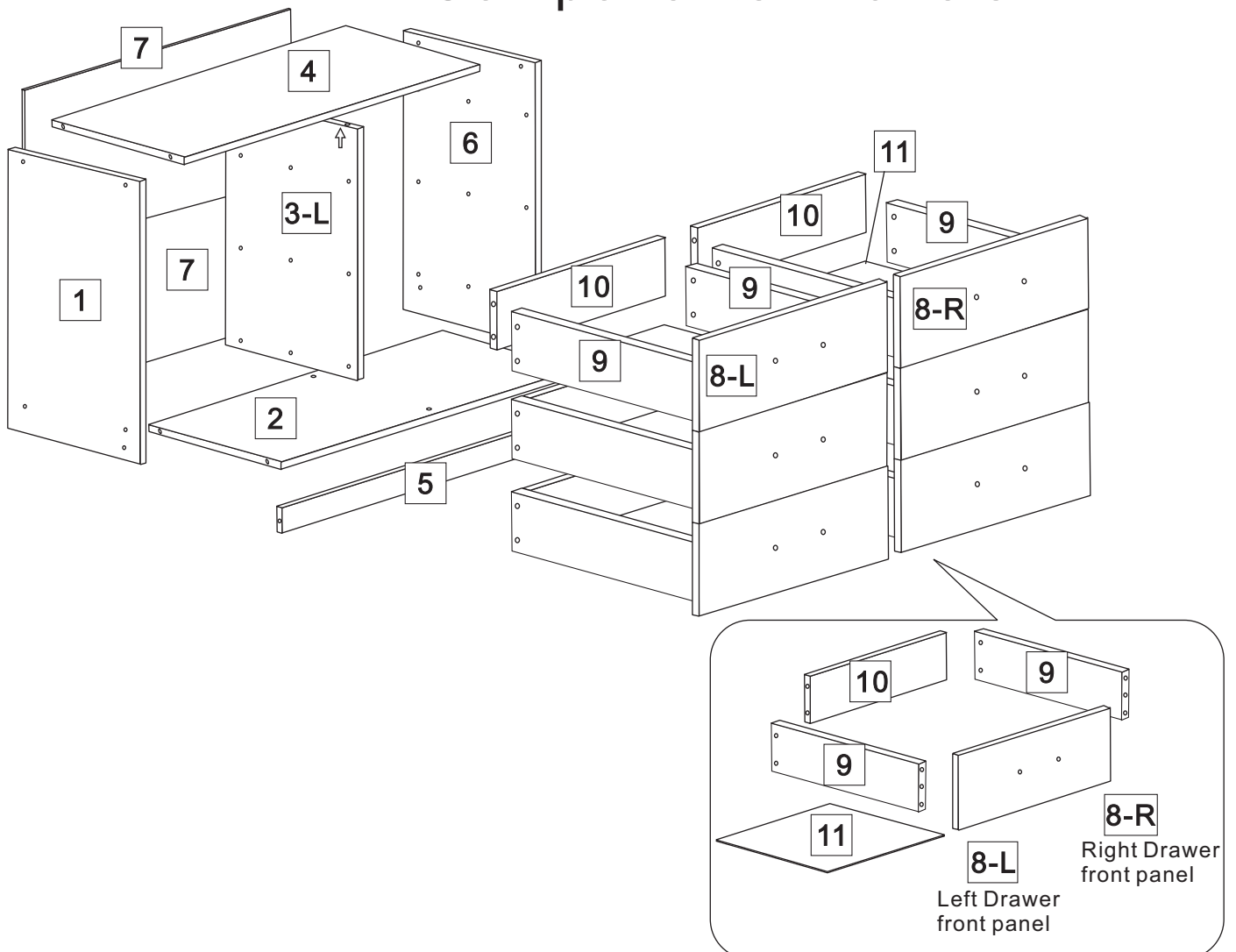











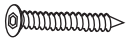

# Components - Fixings



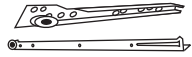

Please check that you have all the components listed below before constructing your item.

**Note:** The quantities below are the correct amount to complete the assembly. In some cases more fittings may be supplied than are required.

## HARDWARE

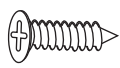
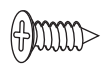
(A)  JCBC M5 X 40mm X 12	(B)  M4 X 32mm X 24	(C)  Button Head 18mm X 12	(D)  M3.5 X 14mm X 72	(E)  Dowel (M8 X 25) X 26
(F)  Nail X 85	(G)  Handle X 6	(H)  Bolt Nut MiniFit X 12 set	(I)  Leg Pin X 5	(J)  Drawer Slide X 6 set
(K)  Allen Key X 1				

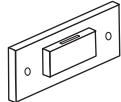
## ANTI - TIPPING KITS

(L)  M4 X 32mm X 4	(M)  M3.5 X 20mm X 4	(N)  Wall Plug X 4	(O)  Bracket X 4	(P)  Strap X 2
---	---	---	---	---

## Tools Required ( Not Provided )



## Ruler - Use this to measure your screws (mm)

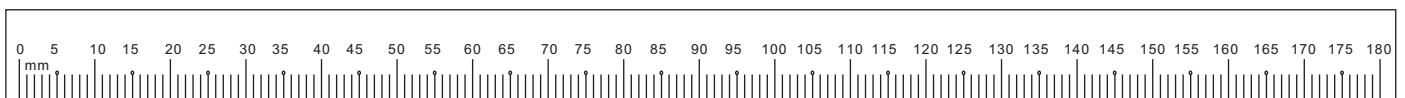

## Important-Please read these instructions fully before starting assembly

# Assembly Instructions

**Step 1** Attach drawer slide rail (J) to Panel boards 1, 3 & 6 with screw (D) onto the specific pre-drilled pilot holes as shown below.

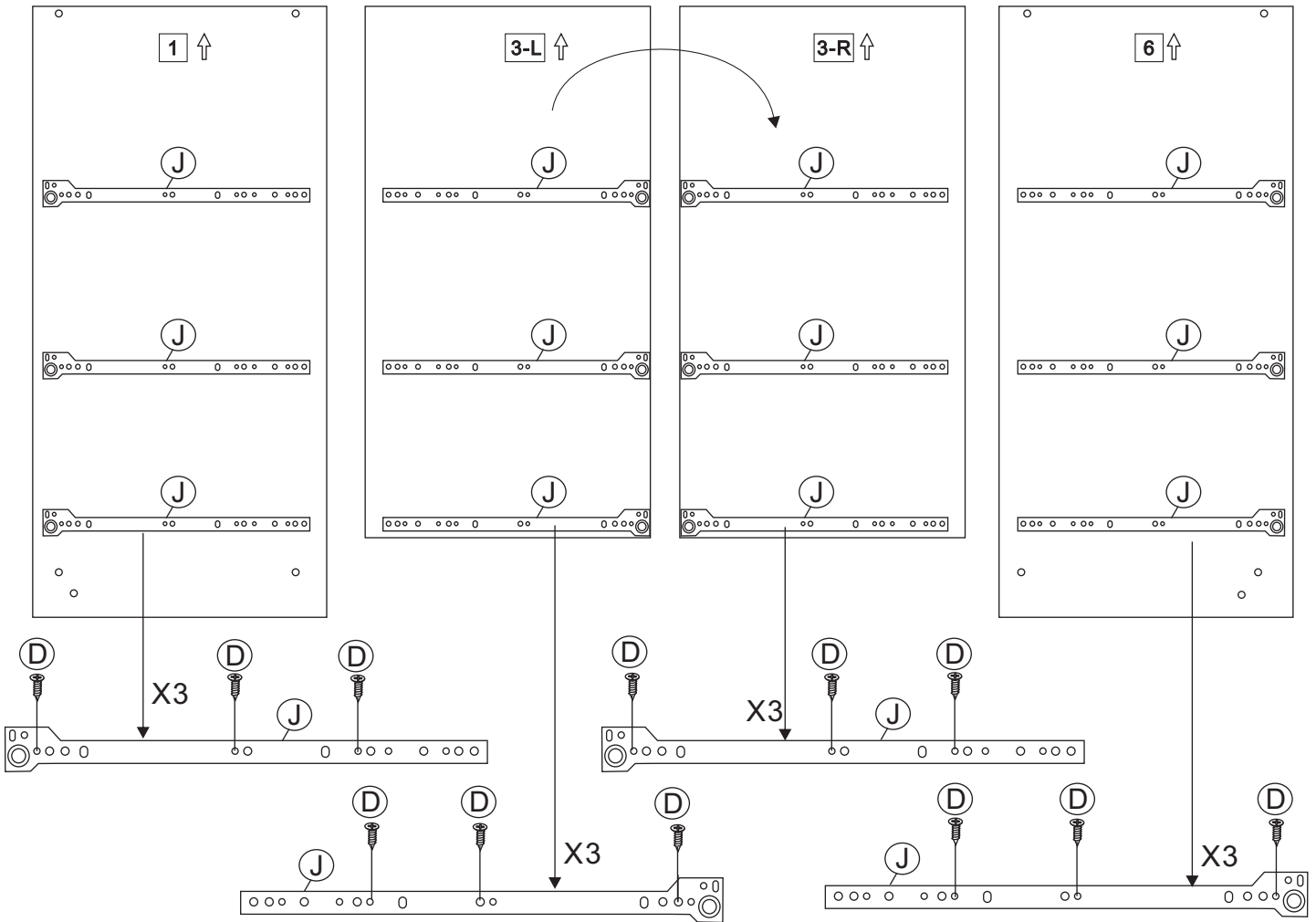

**Step 2a**  
Attach minifit bolt (H) to Drawer front panel (8)

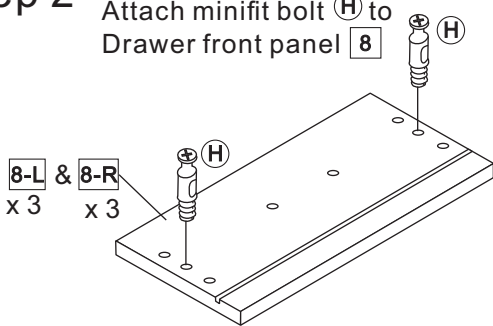

**Step 2b**  
Attach Dowel (E) and Minifit Nut (H) to drawer side panel (9)

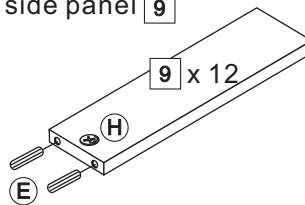

**Step 2c**  
Attach Dowel (E) to centre panel (3)

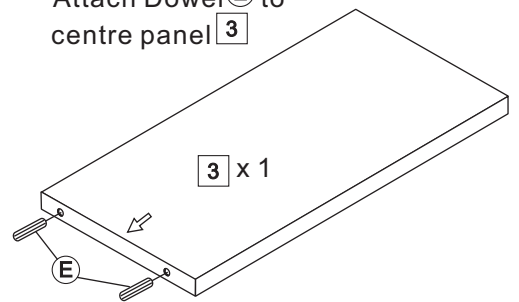

**Step 3a**  
Attach Handle (G) to drawer front panel (8) with Bolt (C)

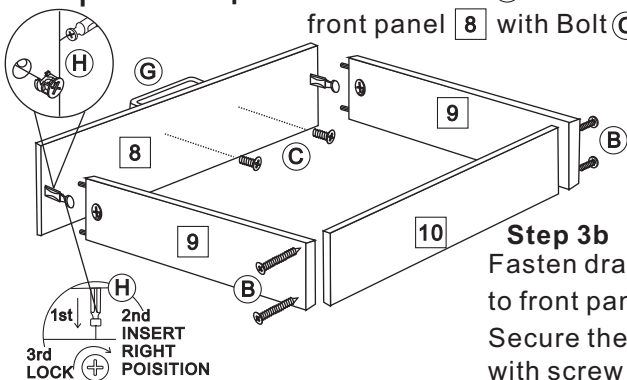

**Step 3b**  
Fasten drawer side panel (9) to front panel (8) with minifit. Secure the drawer back panel (10) with screw (B) using a screw driver.

**Step 3c**  
Attach base board (11) with nail (F) to the drawer base using a small hammer.

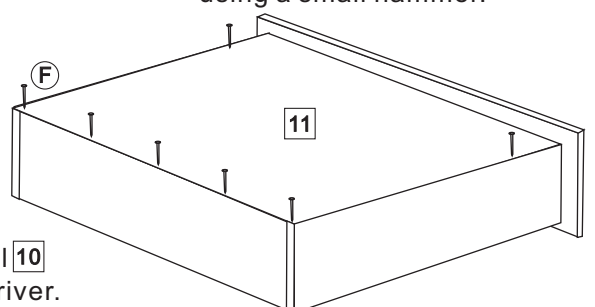

**Step 4** Attach drawer slide rail **J** to drawer base with screw **D** and tighten with screw driver.

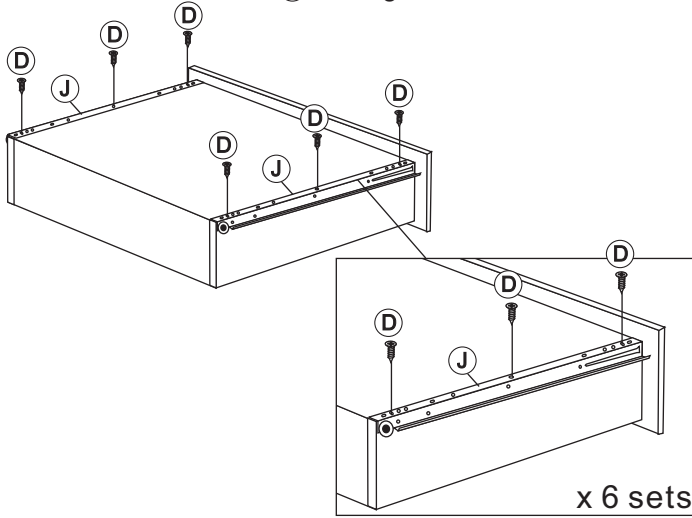

**Step 5** Attach Panel **1**, **3** and **6** to Top panel **4**. Bottom panel **2** and Stretcher panel **5** with screw **A** and tighten with Allen key.

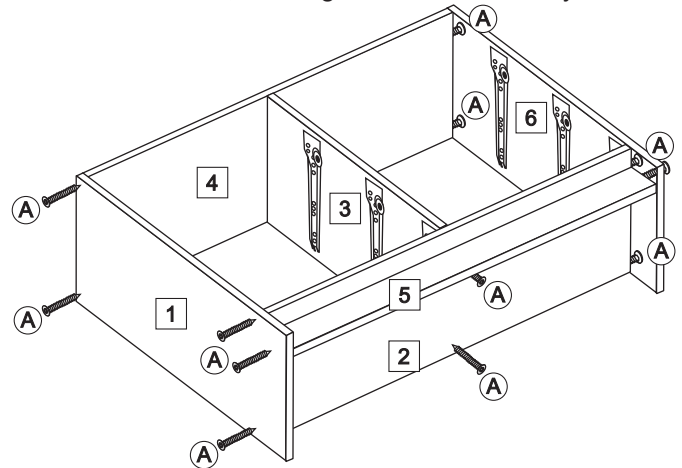

**Step 6**

**step 6b**

Attach Anti tipping kit **O** with **M** at the back of the chest as shown.

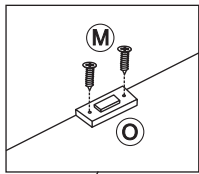

**step 6a** Attach back board **7** to the back of chest, with Nail **F** using a small hammer.

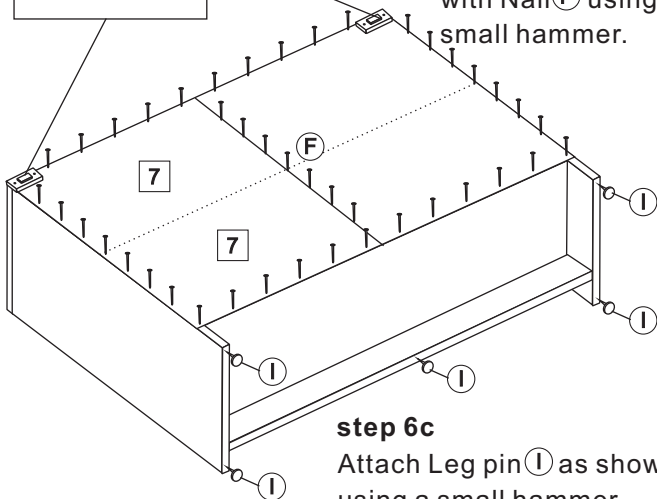

**step 6c**

Attach Leg pin **I** as shown, using a small hammer.

**Step 7** Slide in drawers into the chest carcass frame, with the Drawer front panel marked. **8-L** on the Left Side of the Chest and **8-R** on the Right Side of the Chest

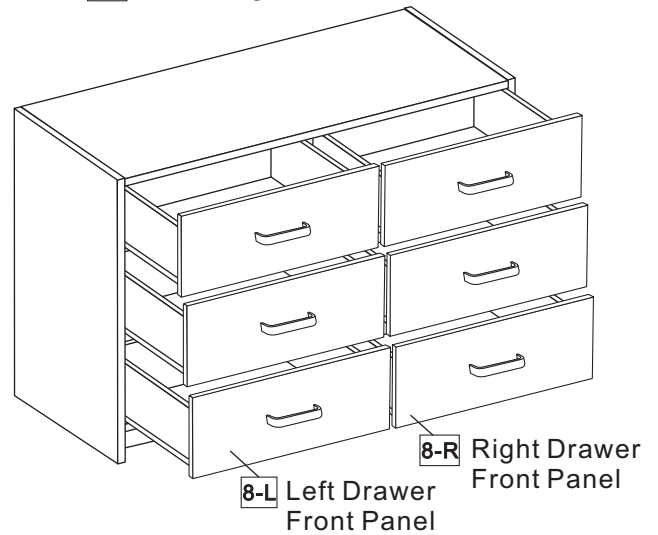

**Step 8**

Attach the Anti-Tipping kit to the wall, following the steps as shown.

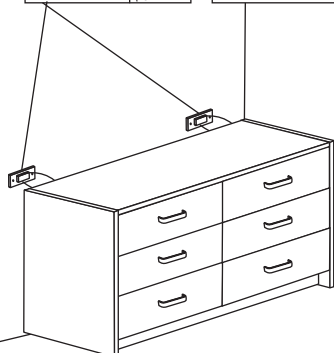
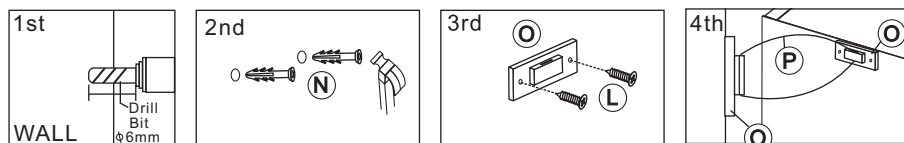

Assembly is complete.