

SPECIAL TIPS FOR FITTING CAM-LOCKS AND QUICKFIT

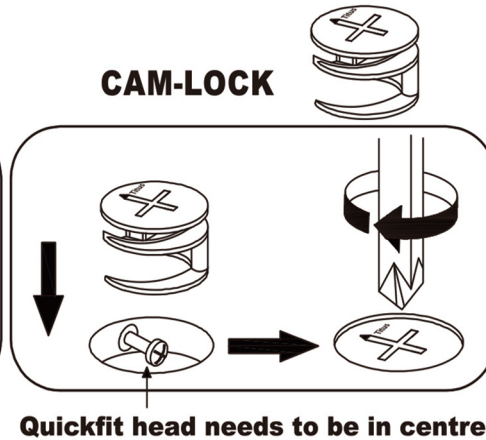

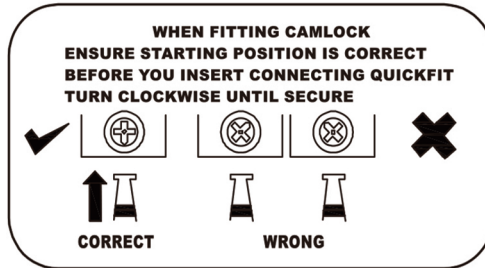

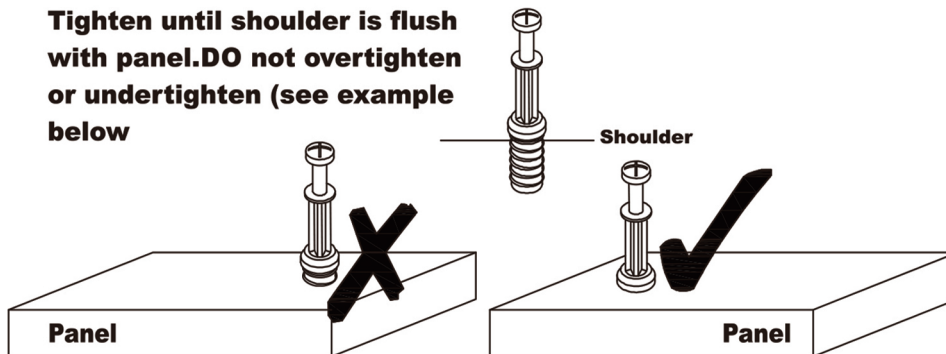







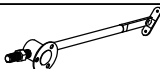



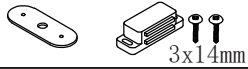

QUICKFIT

Tighten until shoulder is flush with panel. DO not overtighten or undertighten (see example below)



It is recommended that two people assemble this product together.

A	 6x30mm	70pcs	K	 4x18mm	5sets
B	 6x35mm	73pcs	L		2pcs
C	 15x9.5mm	73pcs	M		4pcs
D	 4x35mm	8pcs	N	 4x12mm	8pcs
E	 3x12mm	28pcs	P		2pcs
F	 3.5x12mm	54pcs	Q		2pcs
G	 3x14mm	2pcs	R		1pc
H		9pcs	T	 3x10mm	31pcs
J	 4x25mm	2pcs	U	 6x20mm	2pcs

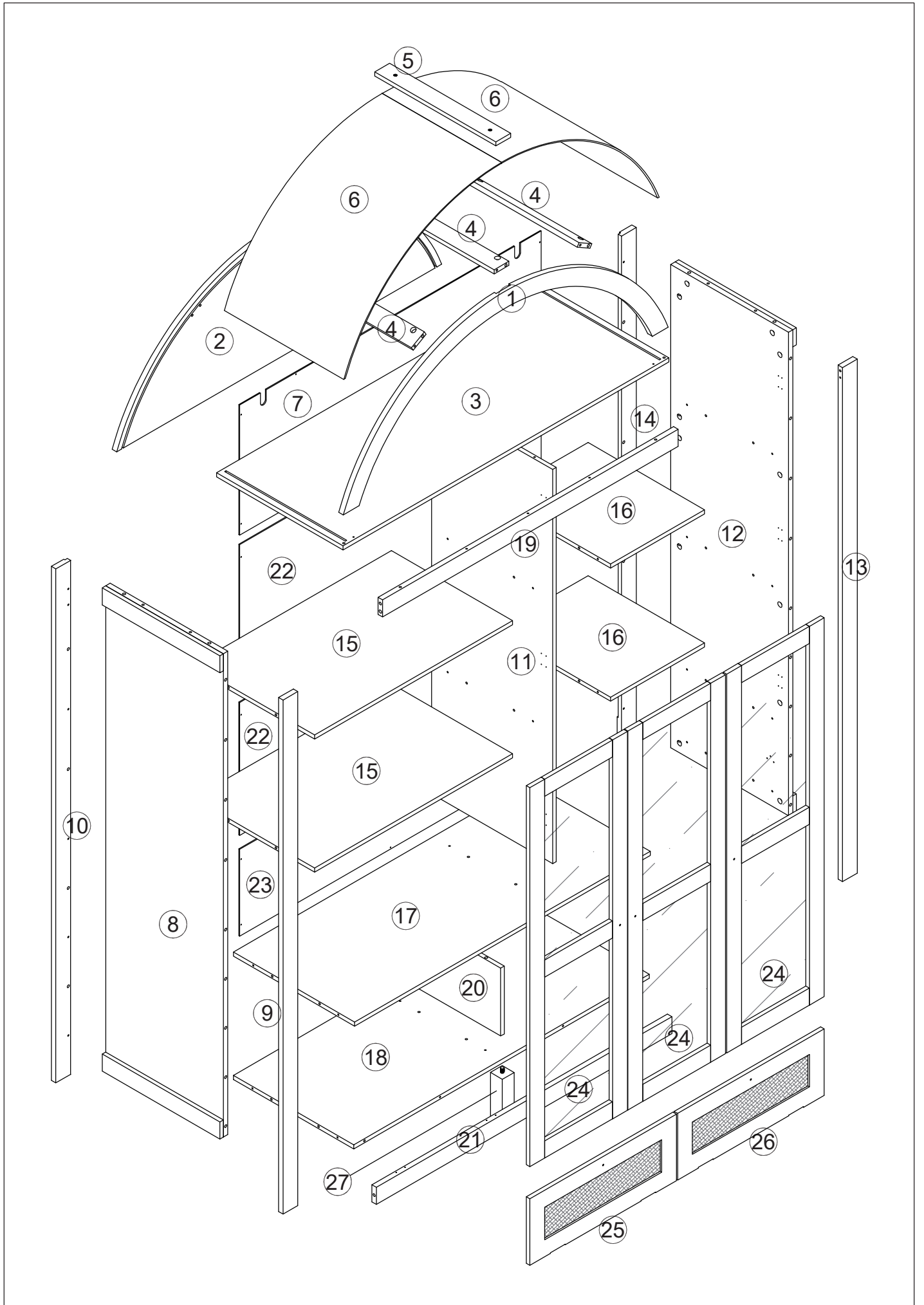

1

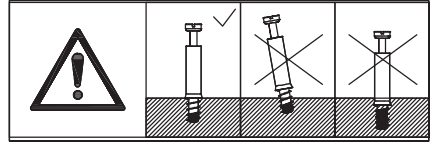
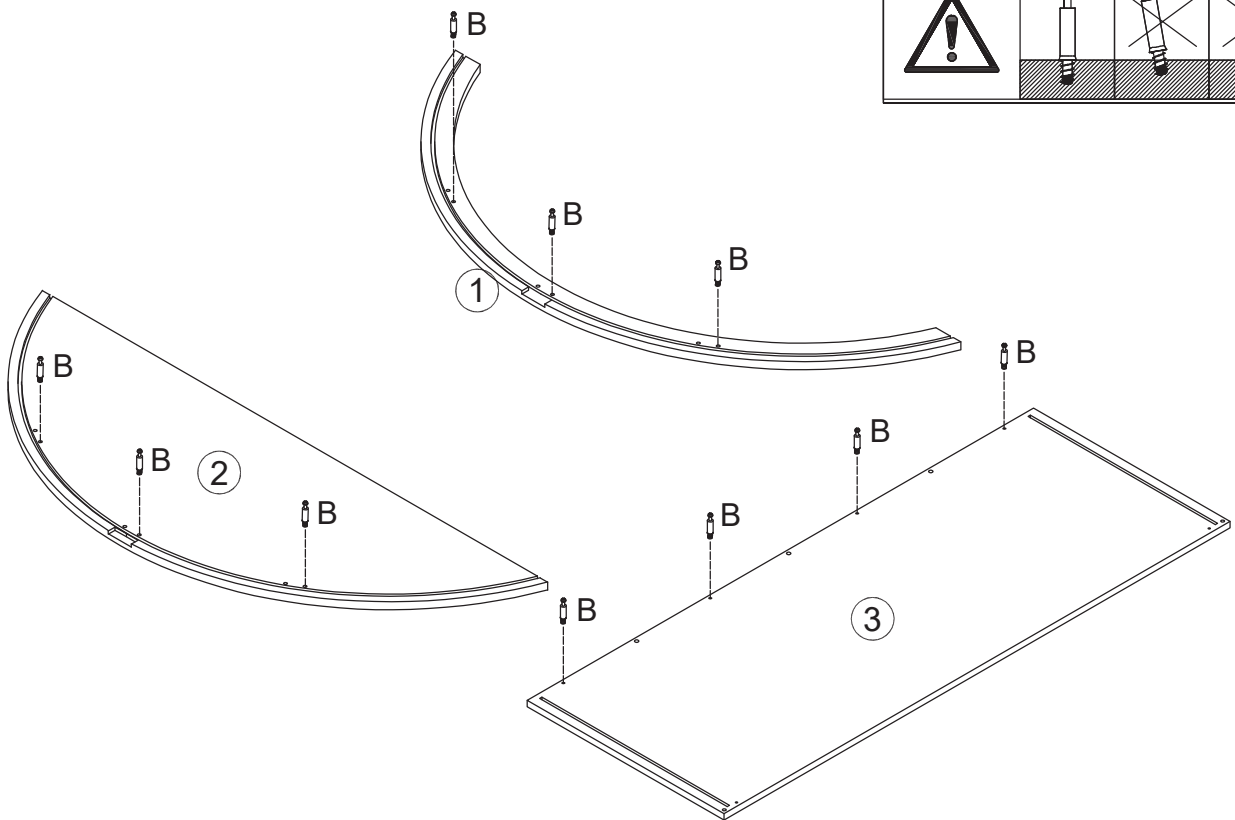

Attach part B to panels #3, arch panel #1 and arch panel #2 .

 (B)x10pcs

2

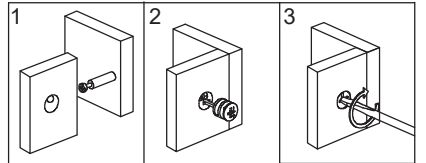
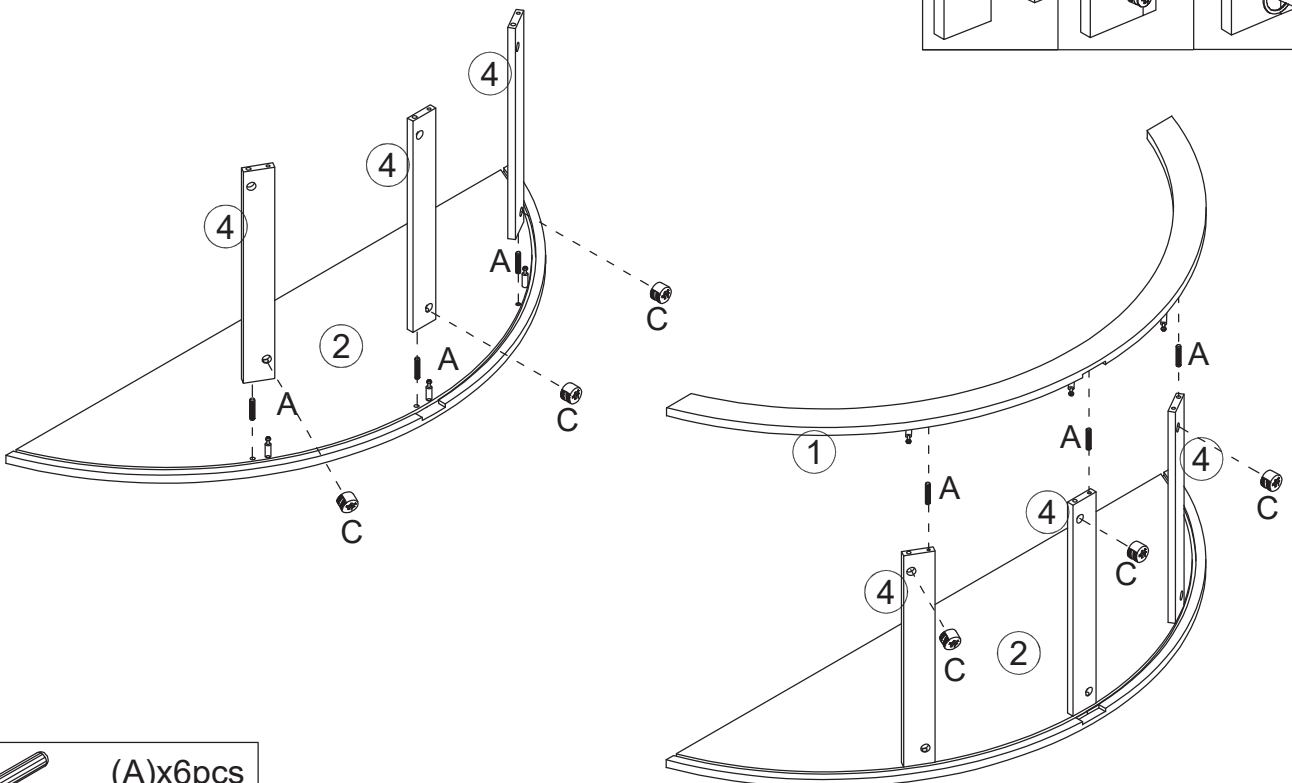

 (A)x6pcs

 (C)x6pcs

3

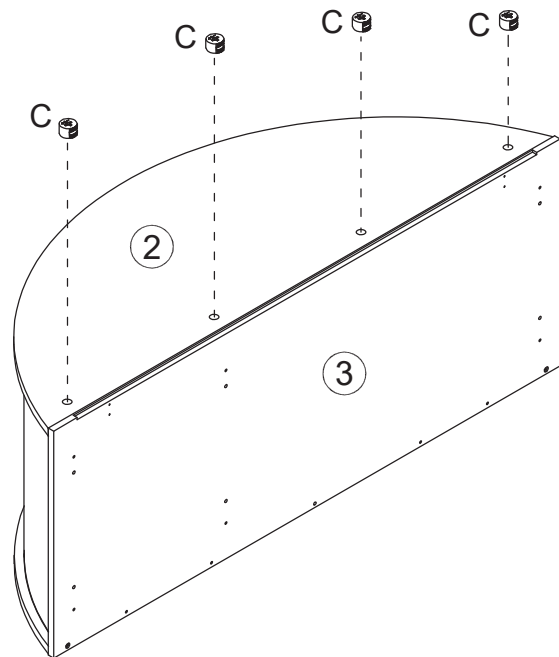
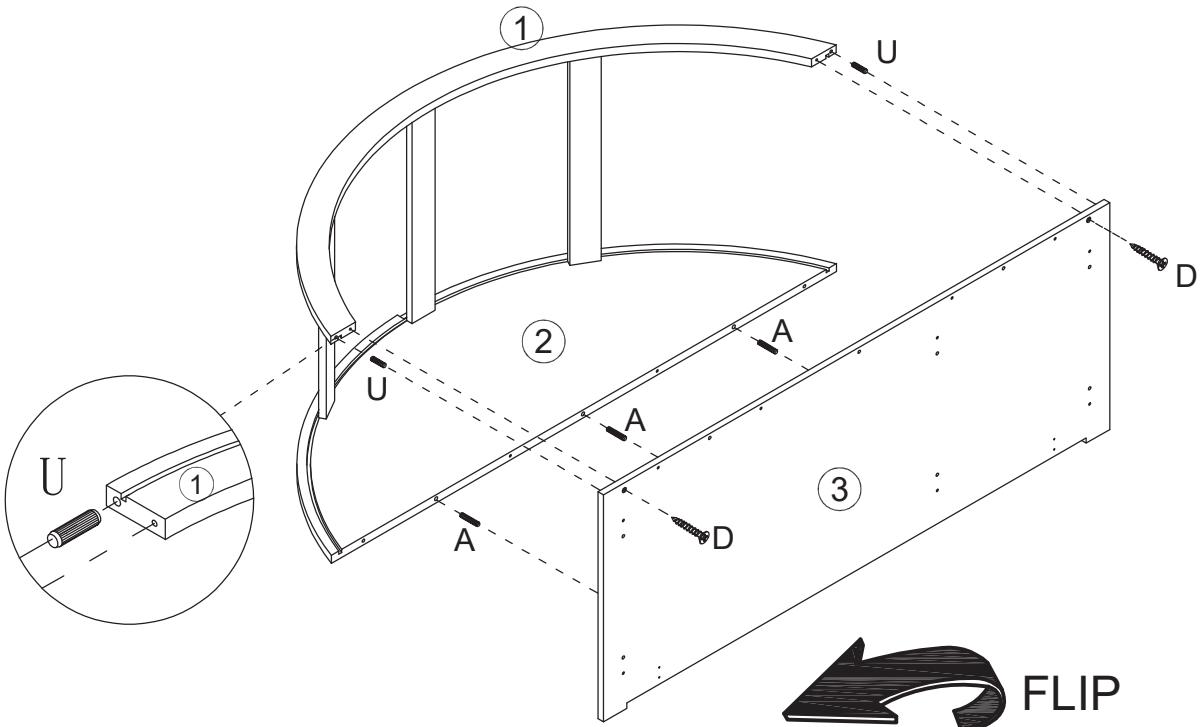
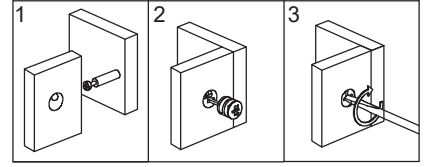

	(A)x3pcs
	(C)x4pcs
	(D)x2pcs
	(U)x2pcs

Insert #U and #A into their corresponding holes. After securing #D, place #C into plate #2 and lock it in place.

4

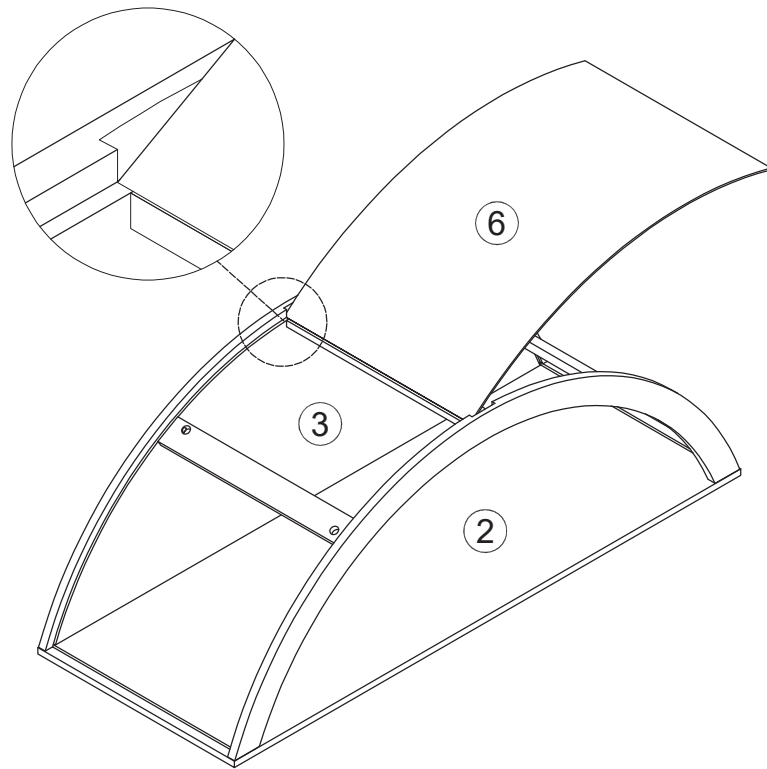

Slide panel 6 into the matching slot.

5

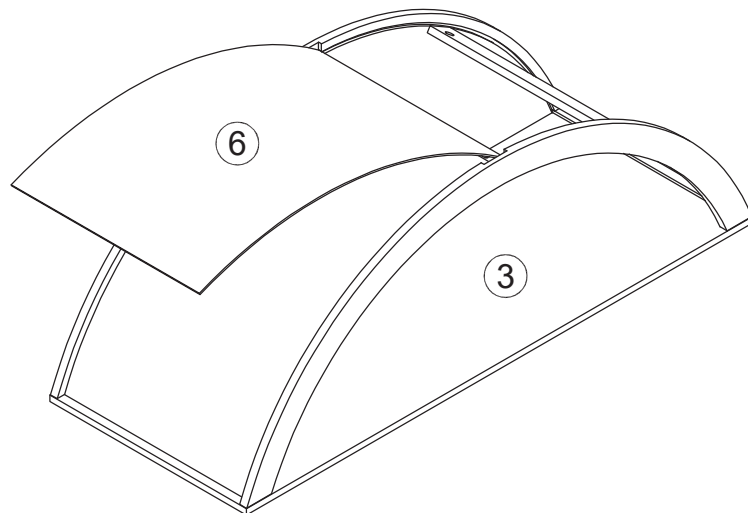

6

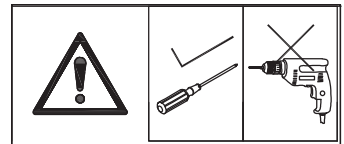

Use part j to nail panel 5 into place to secure panel 6.

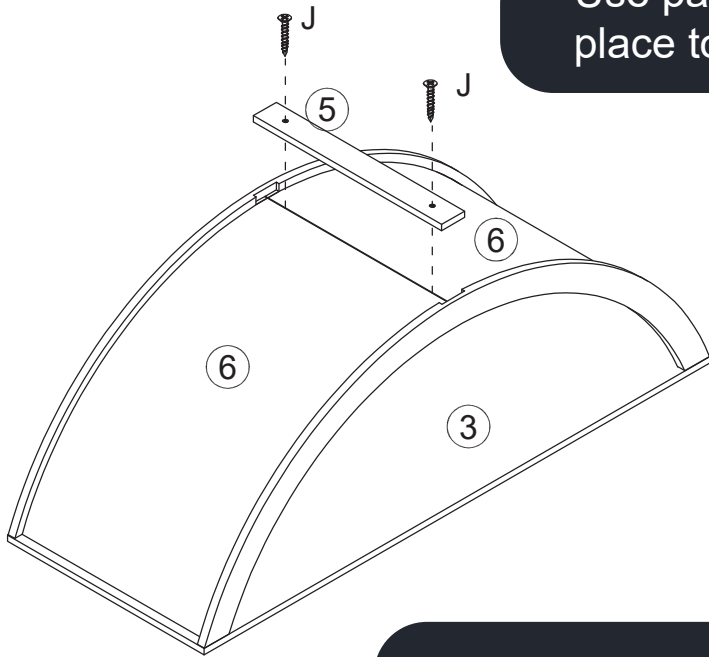



Note: Use a manual screwdriver here.

 (J)x2pcs

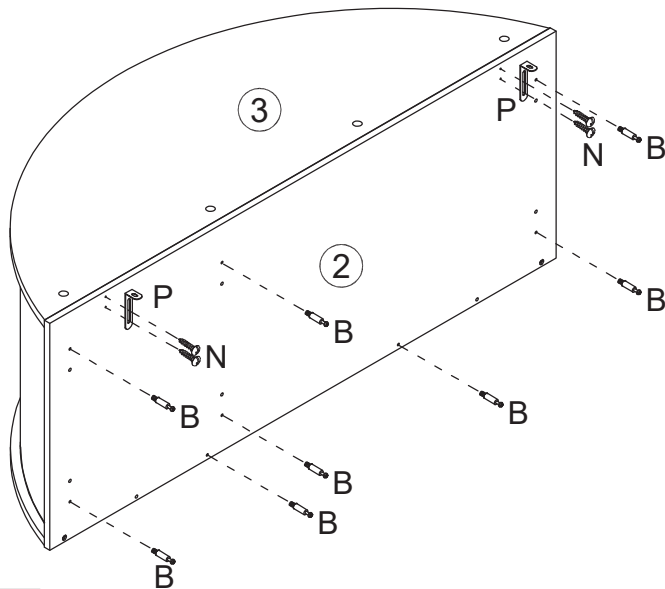
7



Use part N to secure part P.
Note the hole positions for part B.

 (B)x8pcs
 (P)x2pcs
 (N)x4pcs

8

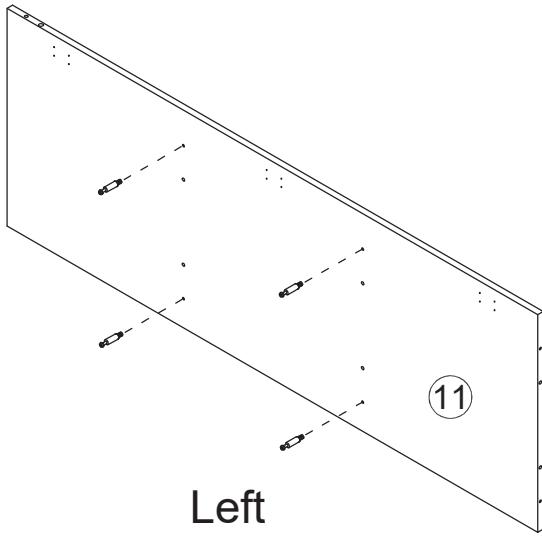
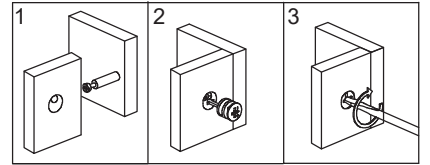

Left

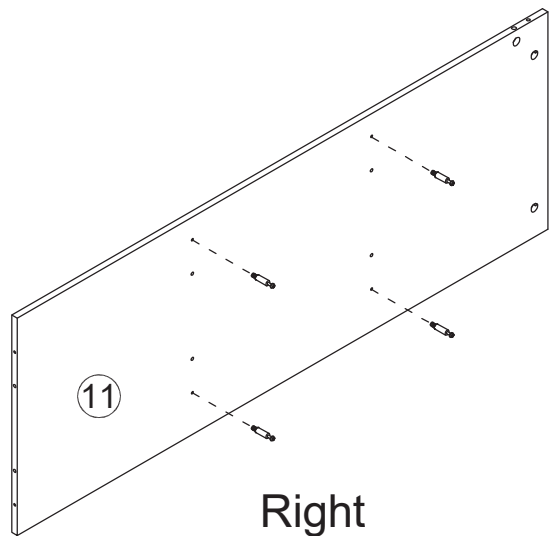

Right

Insert B into the corresponding hole on the #11 panel.



9

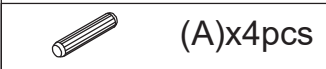
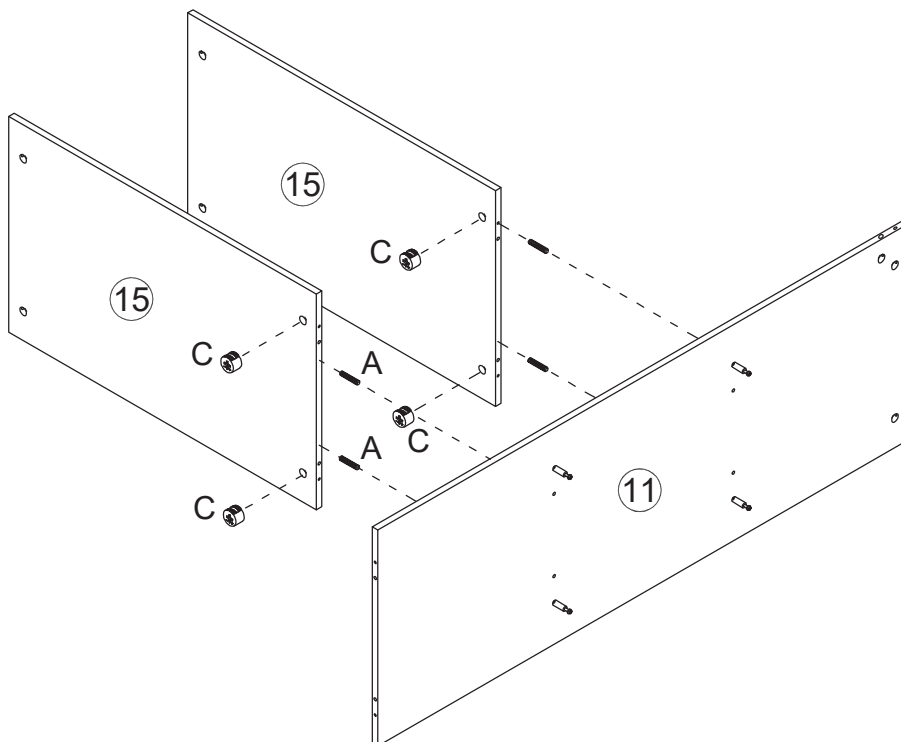

Connect Panel 15 to Panel 11 using Part A. Secure with C- part

10

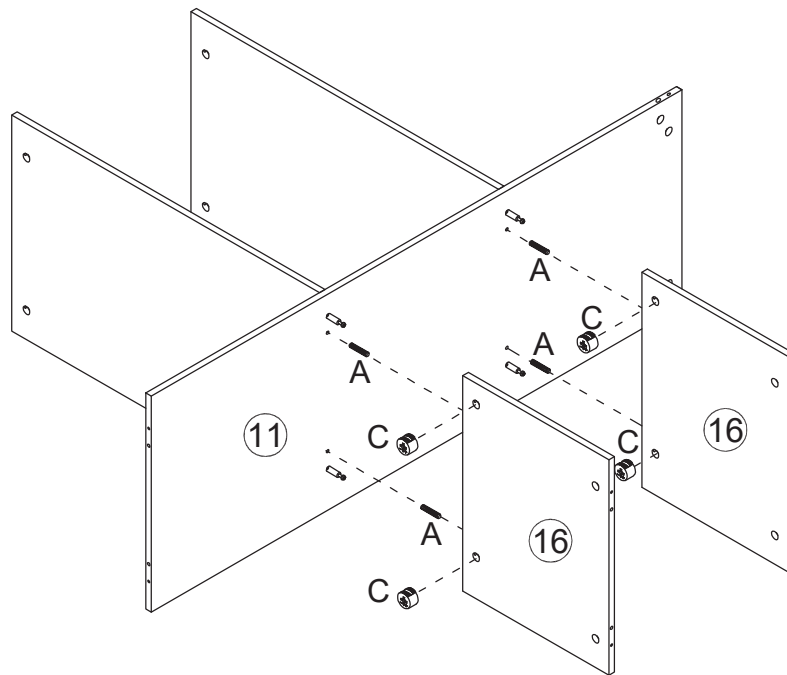

(A)x4pcs



(C)x4pcs

Insert A into the corresponding holes on panels 11 and 16. After connecting, secure with C.

11

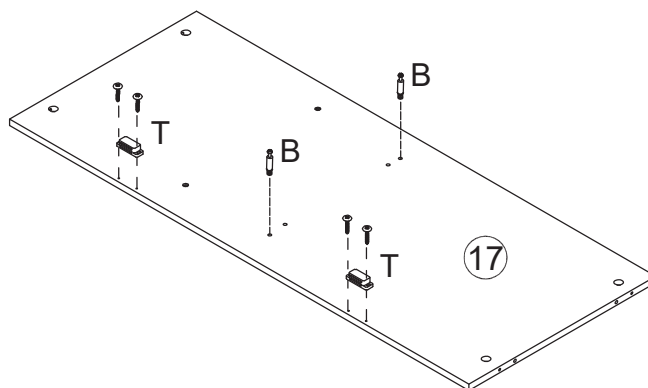

(B)x2pcs



(T)x2sets

Insert B into the corresponding hole on panel 17 and install the T part.

12

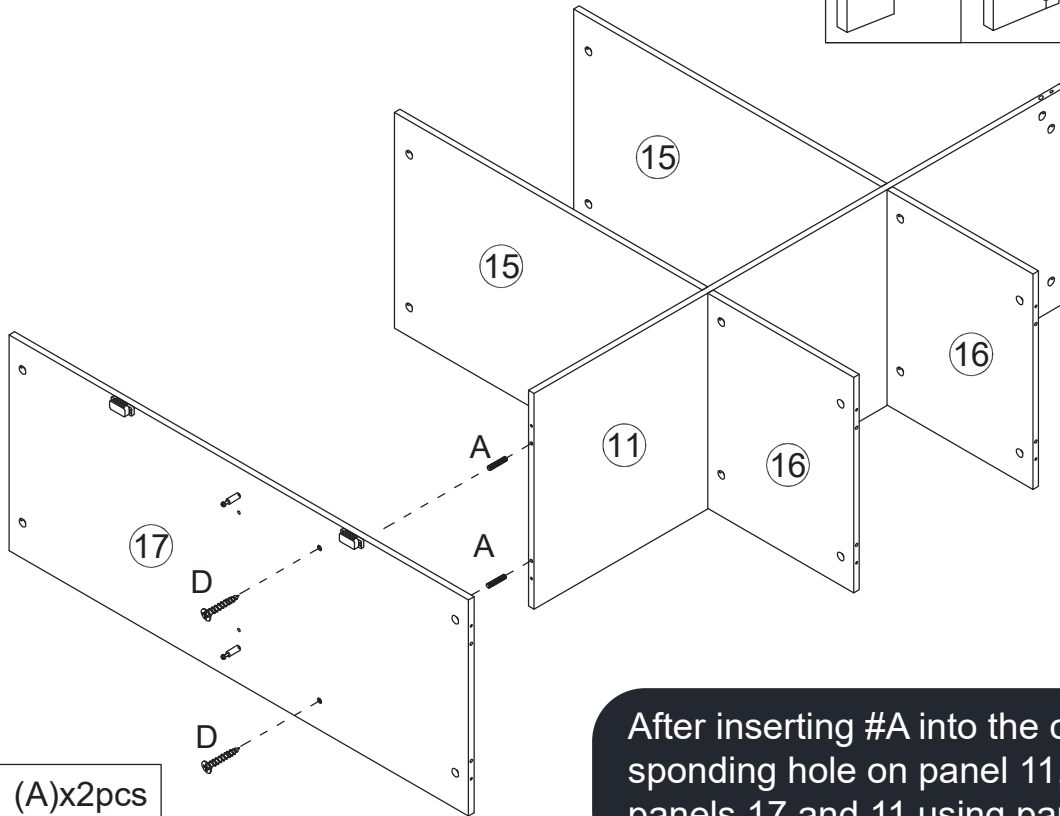
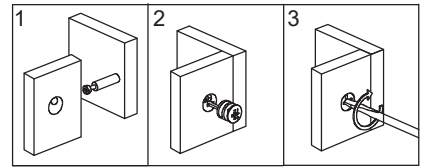

After inserting #A into the corresponding hole on panel 11, secure panels 17 and 11 using part D.

- (A)x2pcs
- (D)x2pcs

13

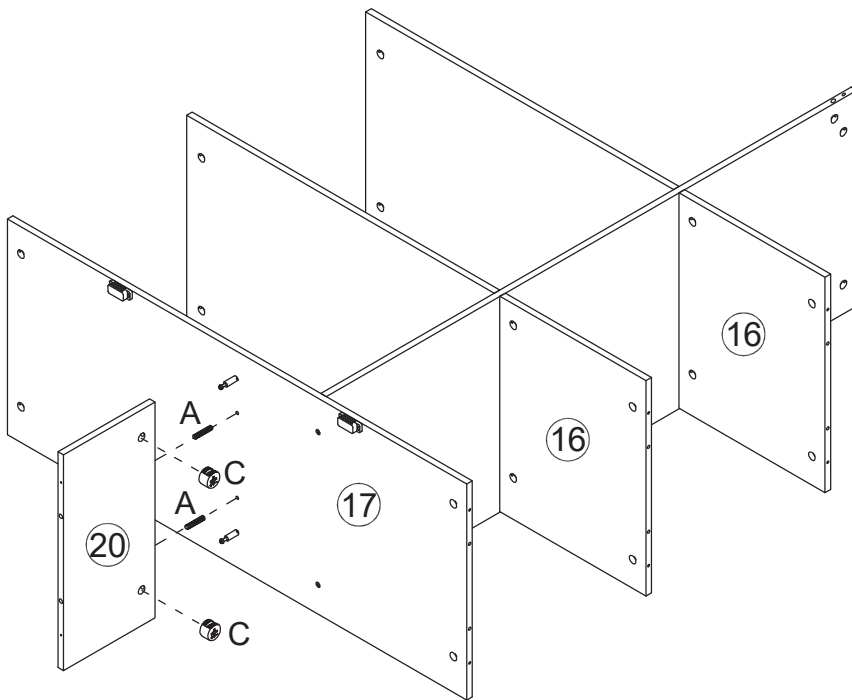
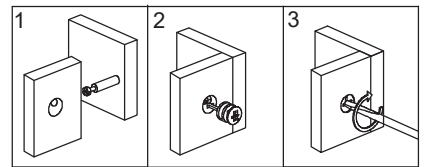

Connect #17 and #20 with A, then secure with C.

- (A)x2pcs
- (C)x2pcs

14

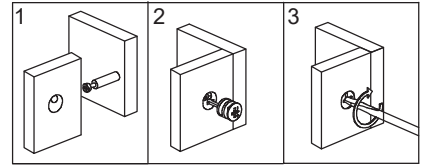
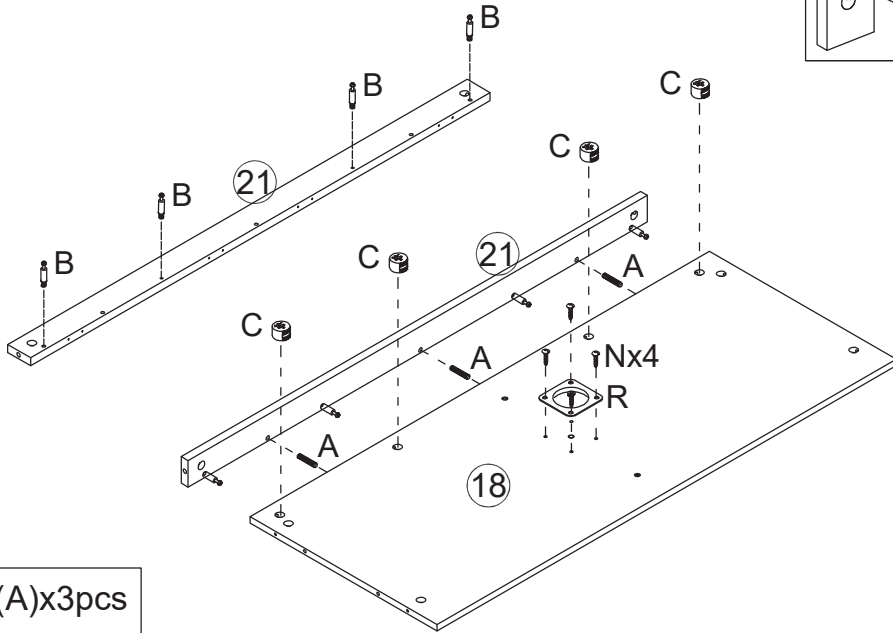

	(A)x3pcs
	(B)x4pcs
	(C)x4pcs
	(N)x4pc
	(R)x1pc

Insert parts A and B into the corresponding holes on panel 21, then connect panel 18 to panel 21. After securing with C, use N to nail the R part into panel 18.

15

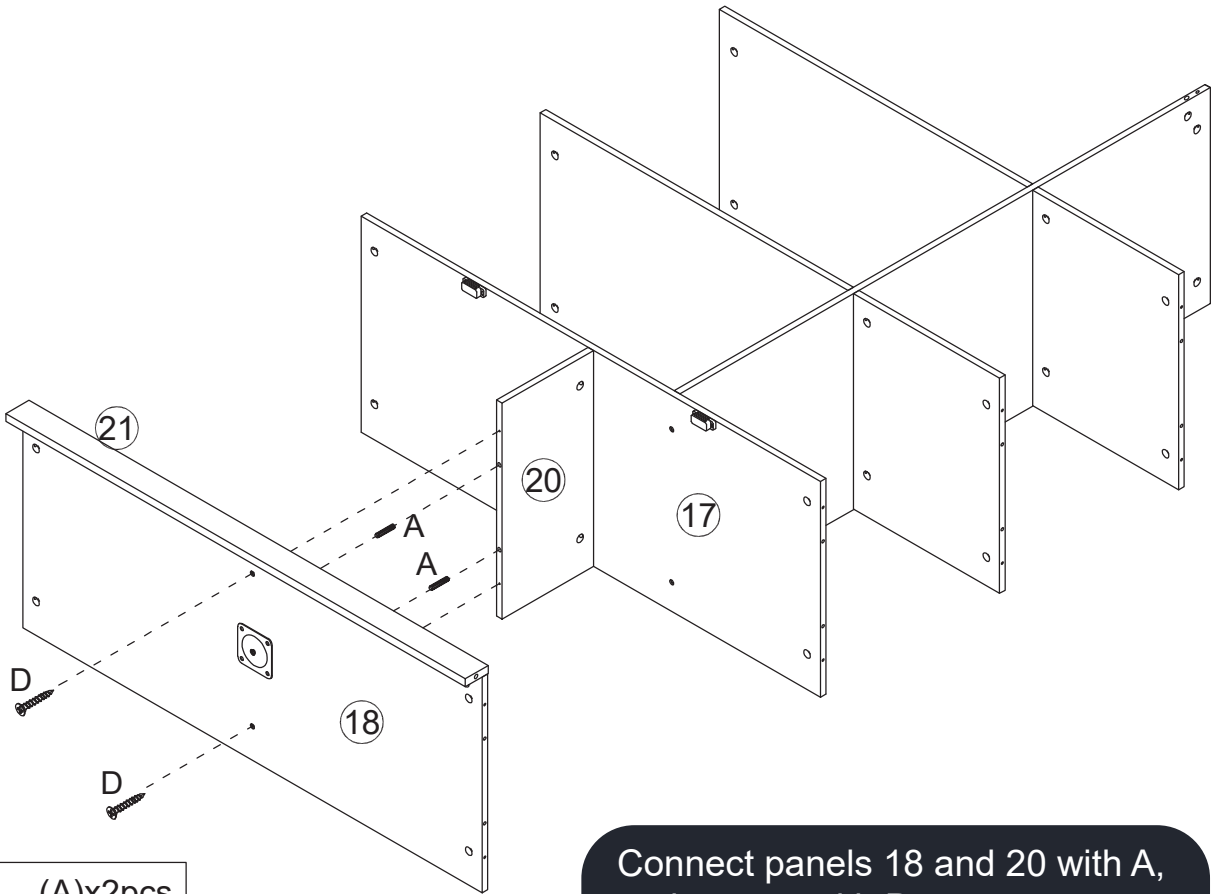



	(A)x2pcs
	(D)x2pcs

Connect panels 18 and 20 with A, and secure with D.

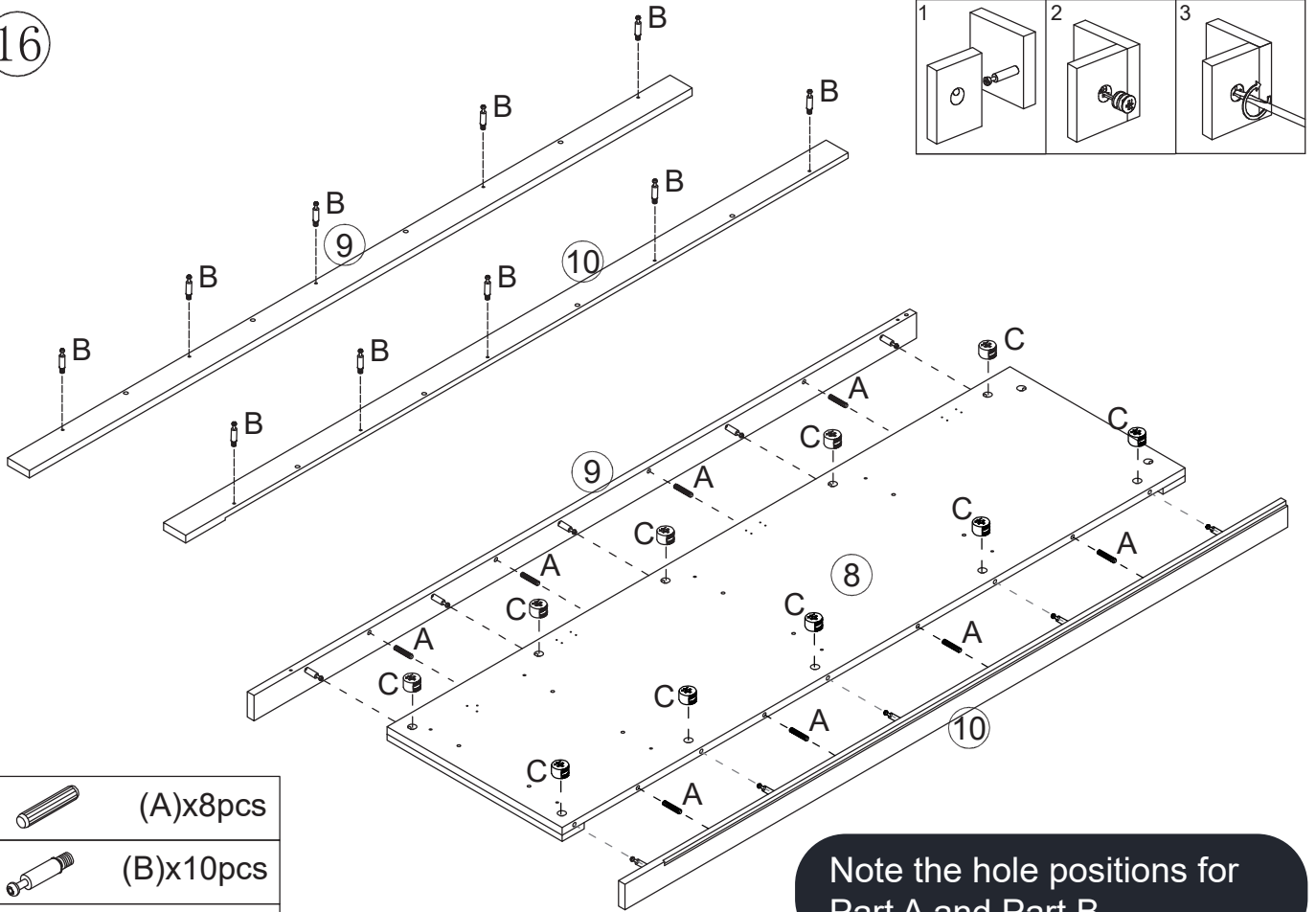
16





Note the hole positions for Part A and Part B.

-  (A)x8pcs
-  (B)x10pcs
-  (C)x10pcs

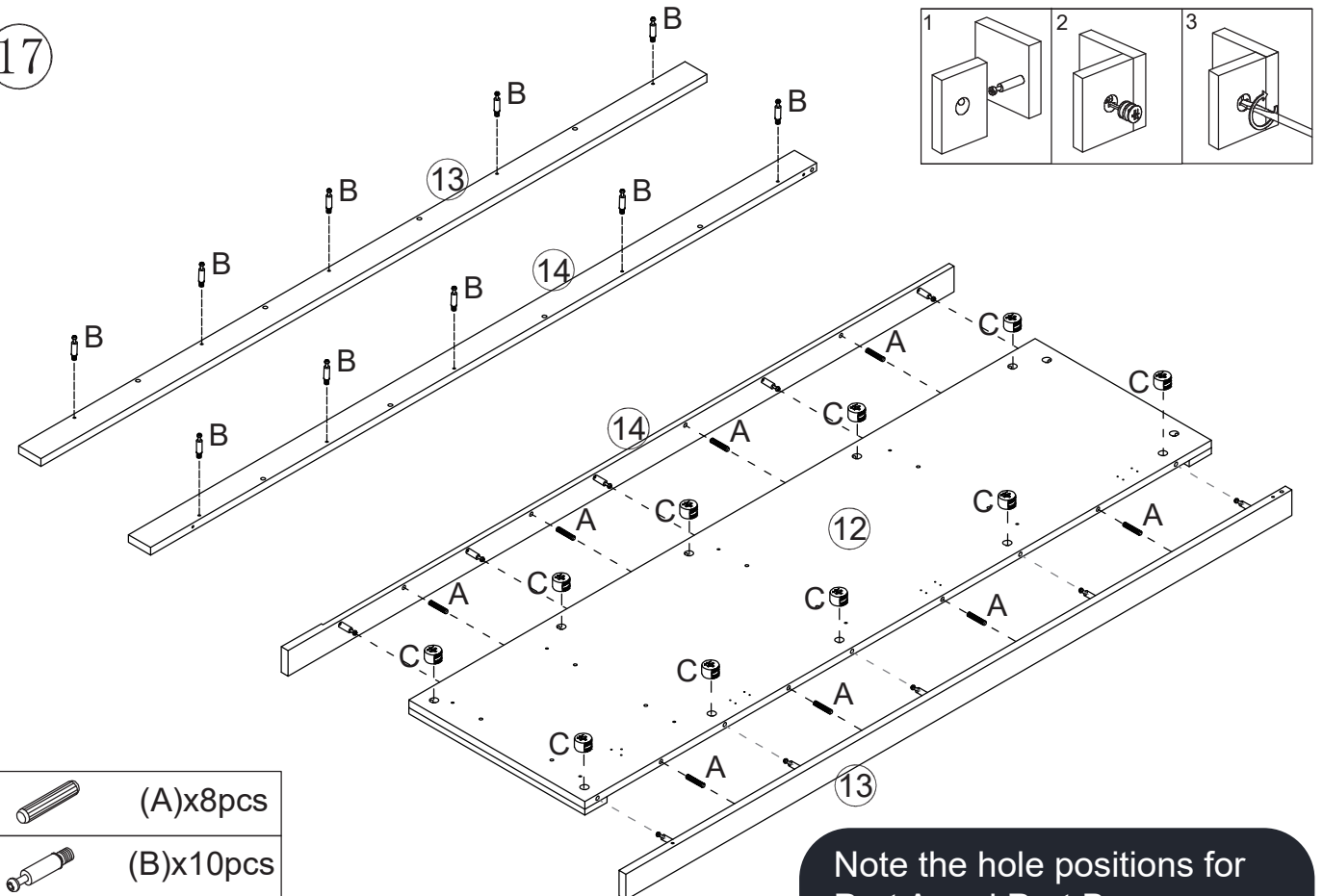
17



Note the hole positions for Part A and Part B.

-  (A)x8pcs
-  (B)x10pcs
-  (C)x10pcs

18

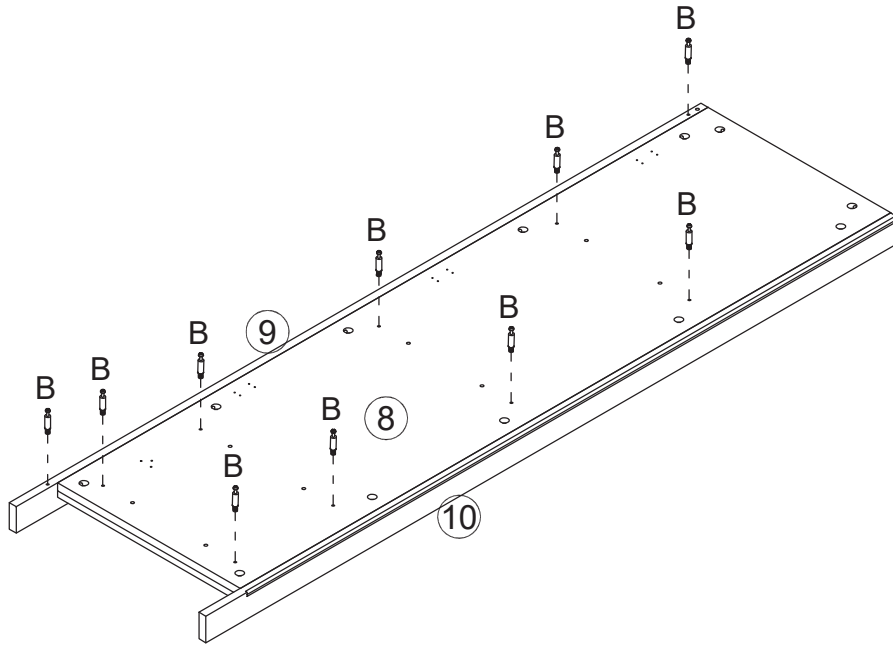

Note the hole positions for Part B.

 (B)x10pcs

19

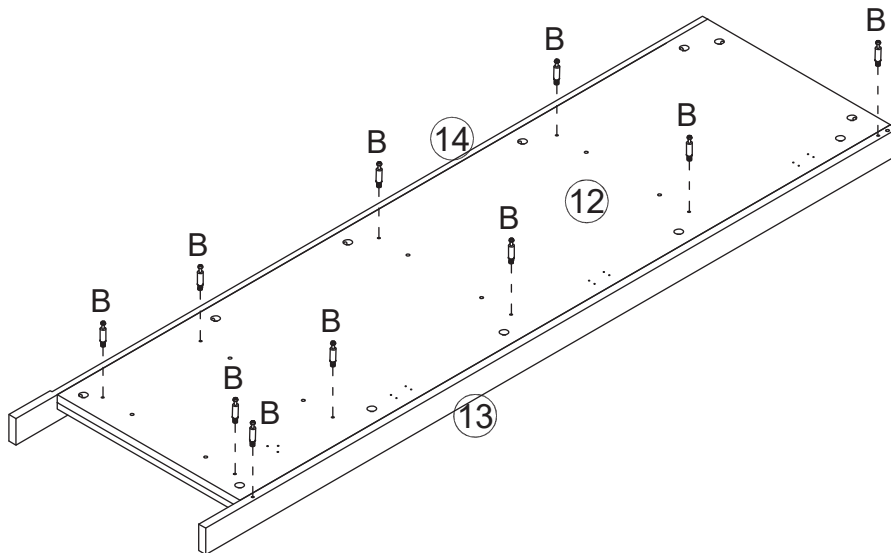

Note the hole positions for Part B.

 (B)x10pcs

20

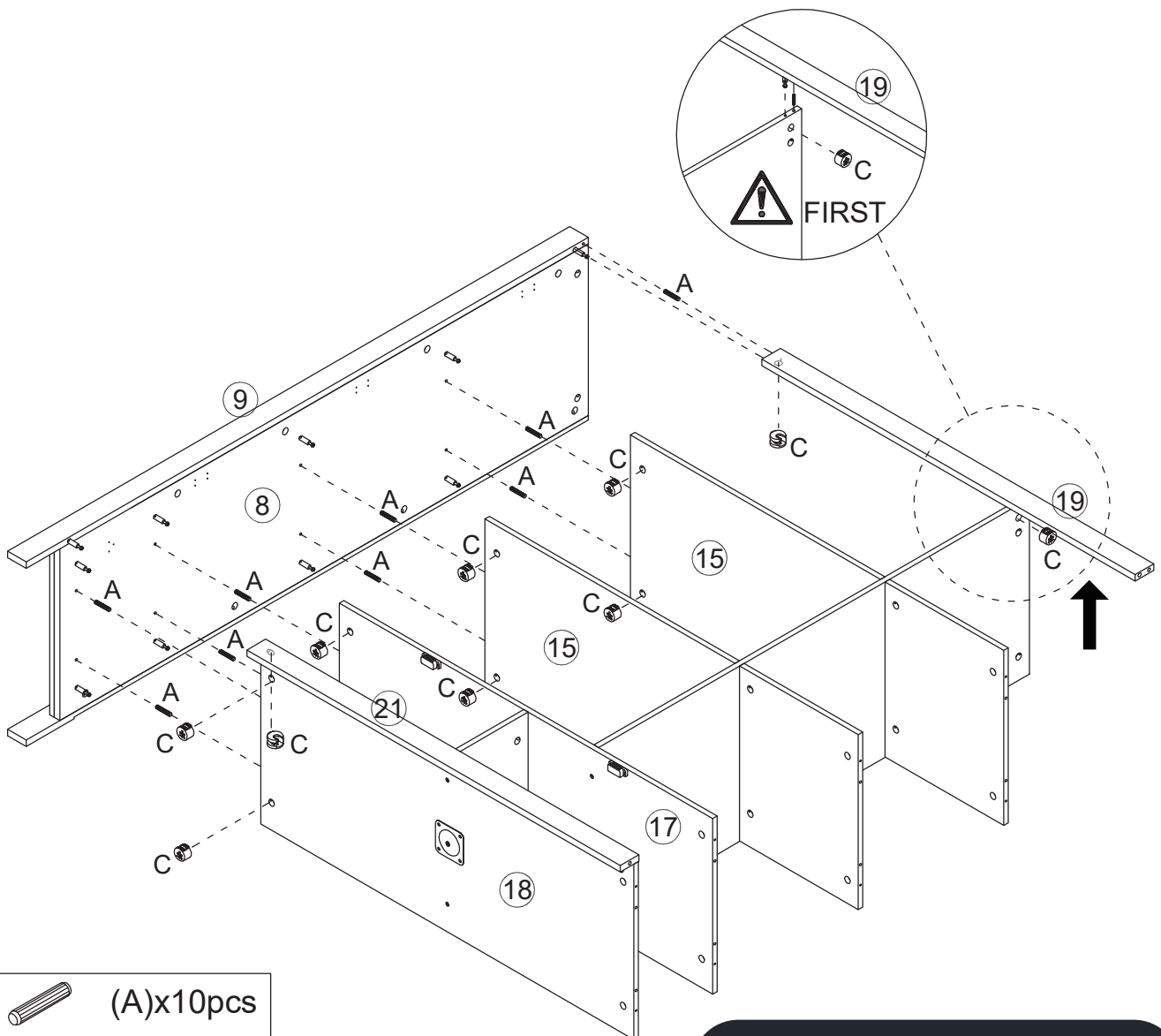
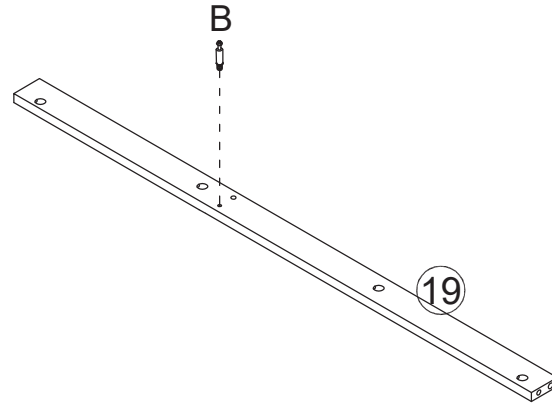
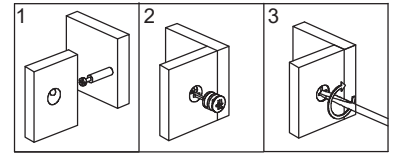



Note: First connect panel 19 to panel 11.

- | | |
|--|-----------|
| | (A)x10pcs |
| | (B)x1pc |
| | (C)x11pcs |

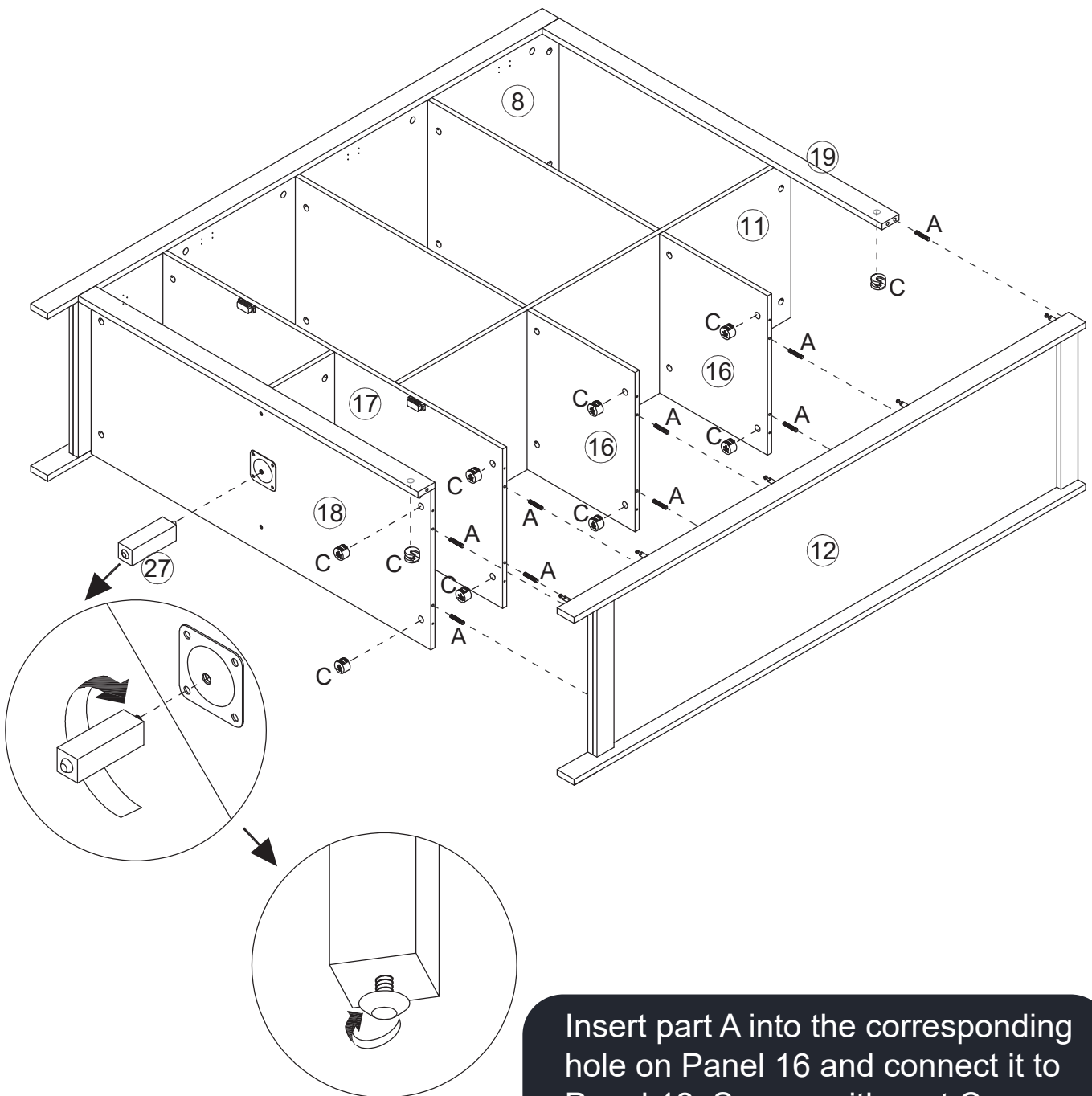
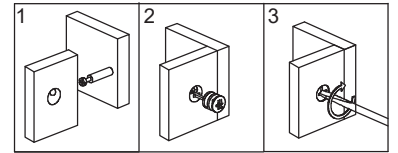
21



Insert part A into the corresponding hole on Panel 16 and connect it to Panel 12. Secure with part C. Connect part 27 to panel 18.

- | | |
|---|-----------|
|  | (A)x9pcs |
|  | (C)x10pcs |

22

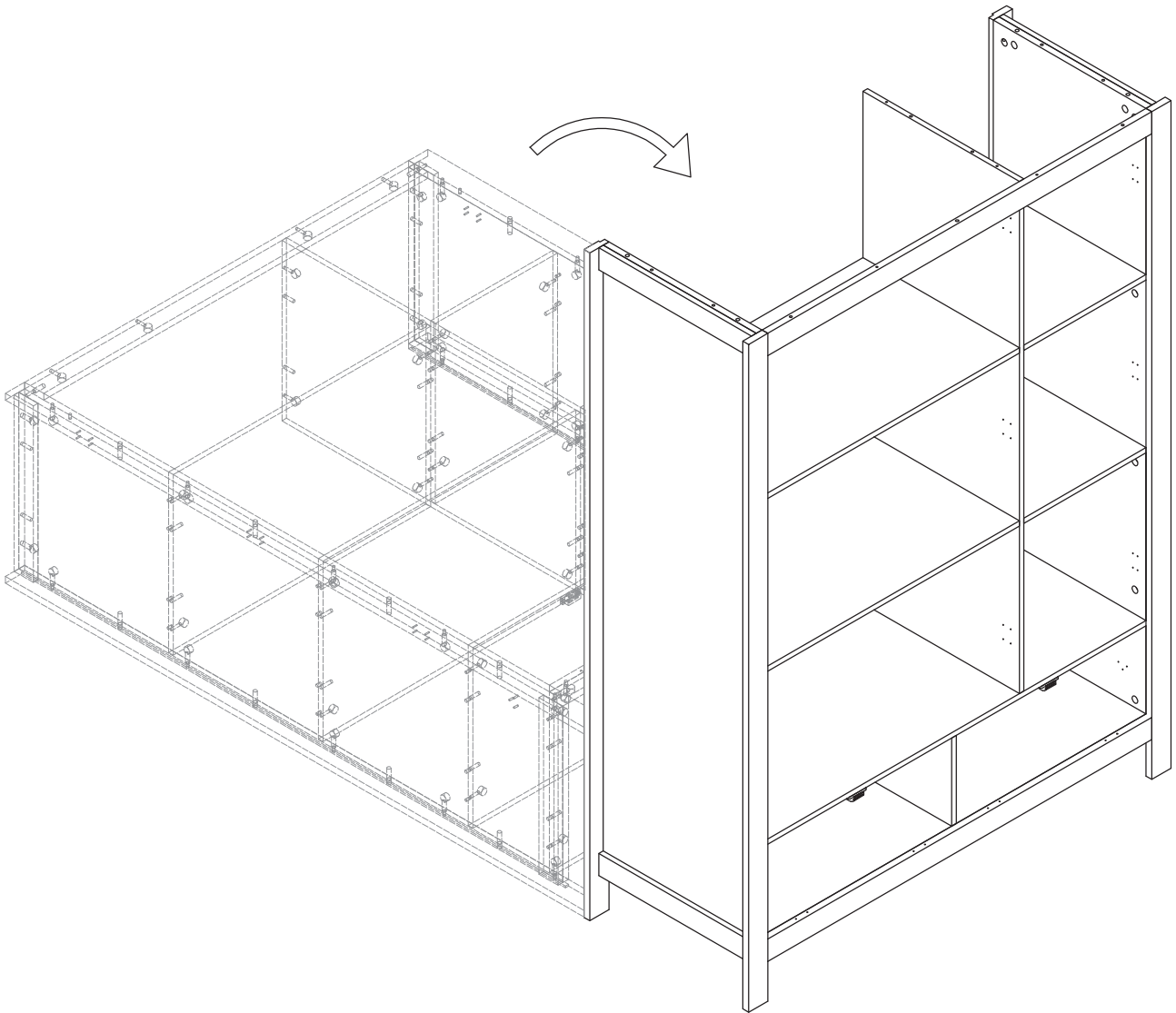
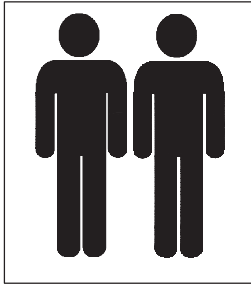

23

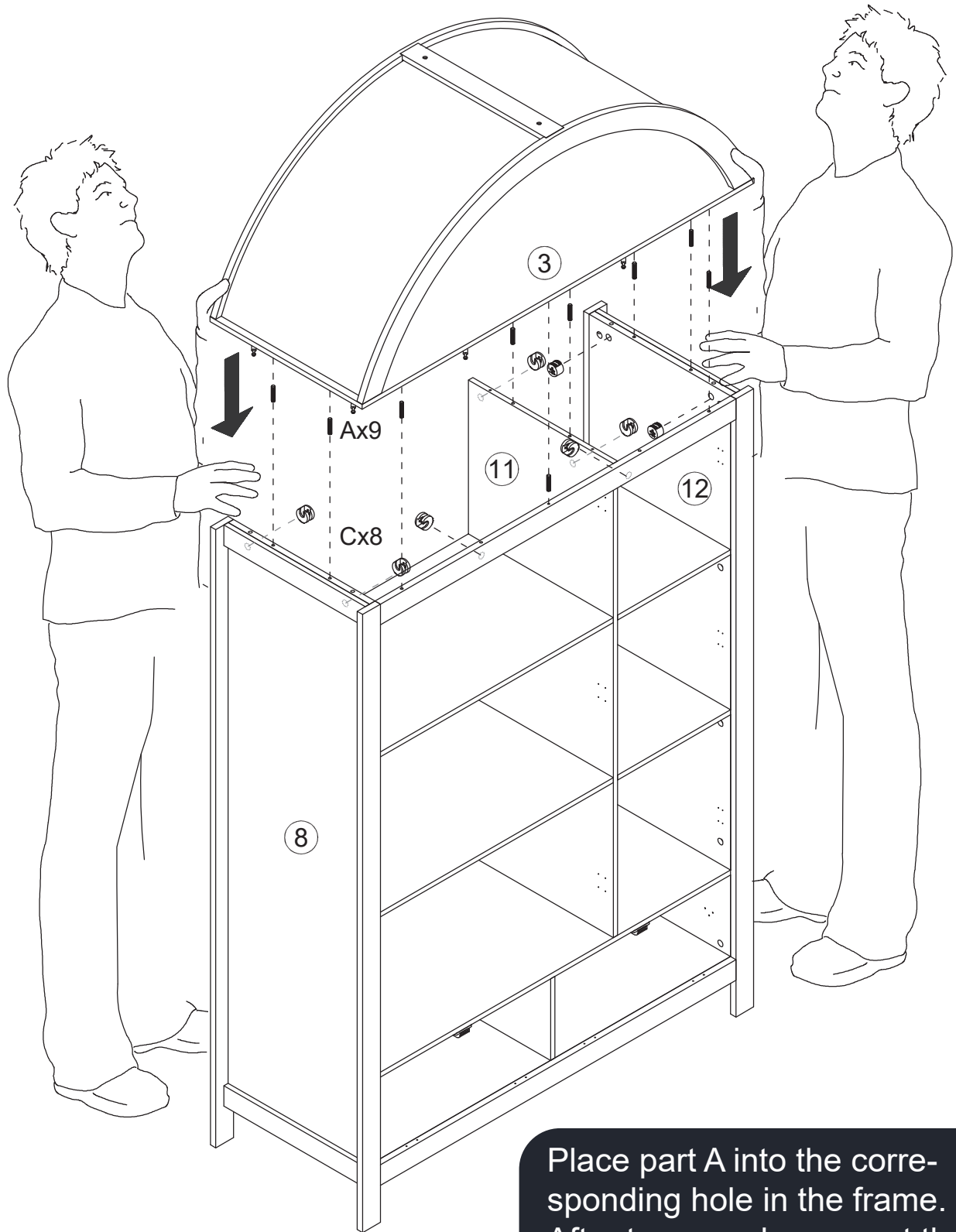
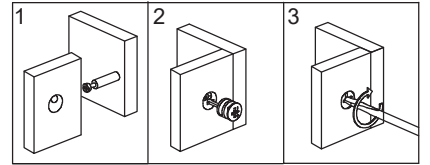

Place part A into the corresponding hole in the frame. After two people connect the arch to the frame, secure it with part C.



(A)x9pcs



(C)x8pcs

24

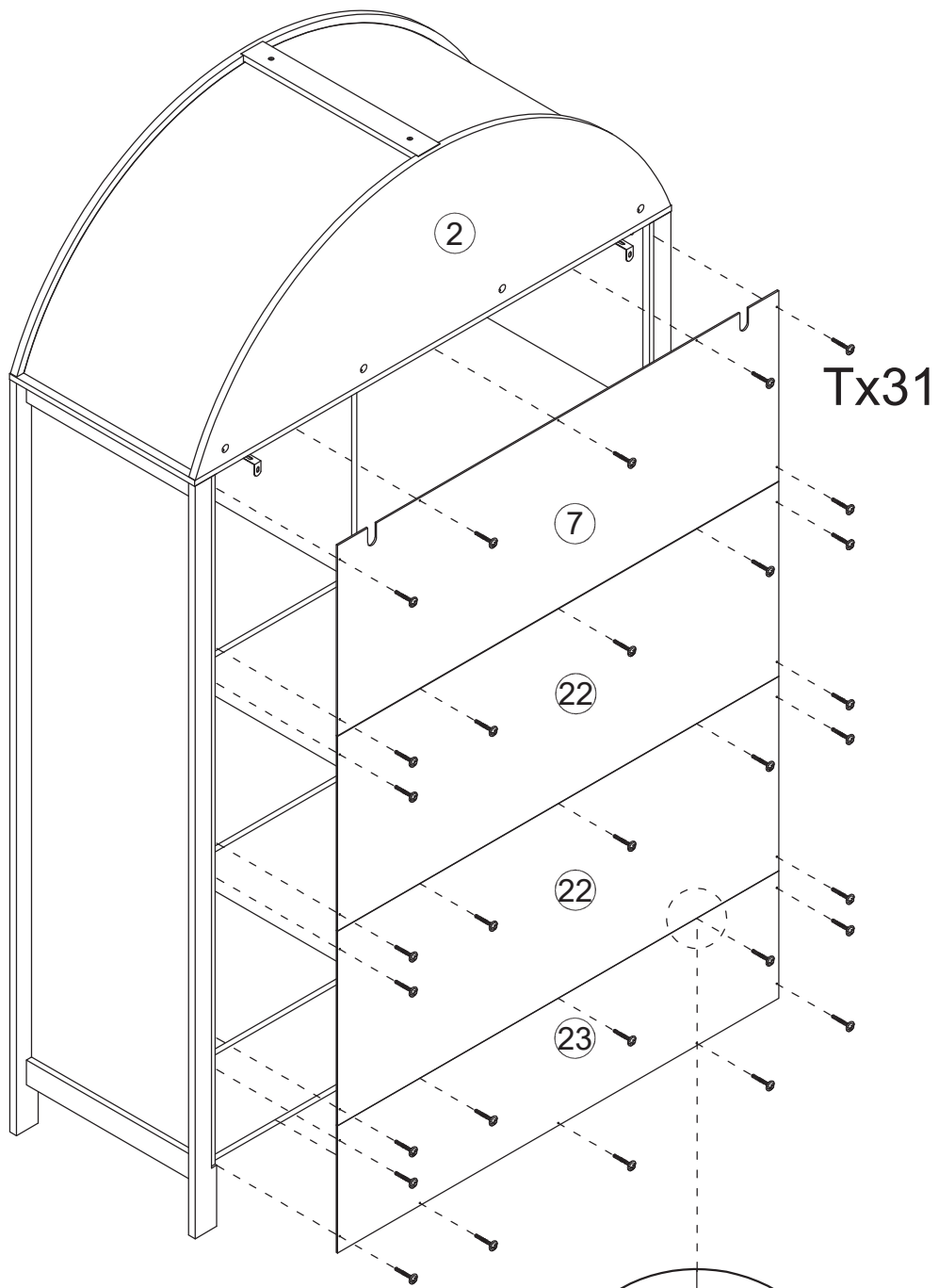



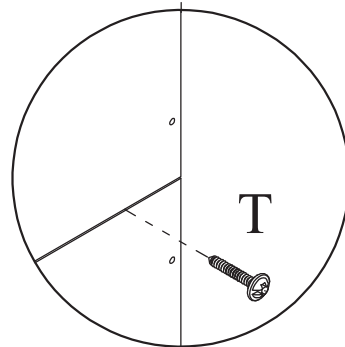



Use part T to nail the back panel into the corresponding holes.

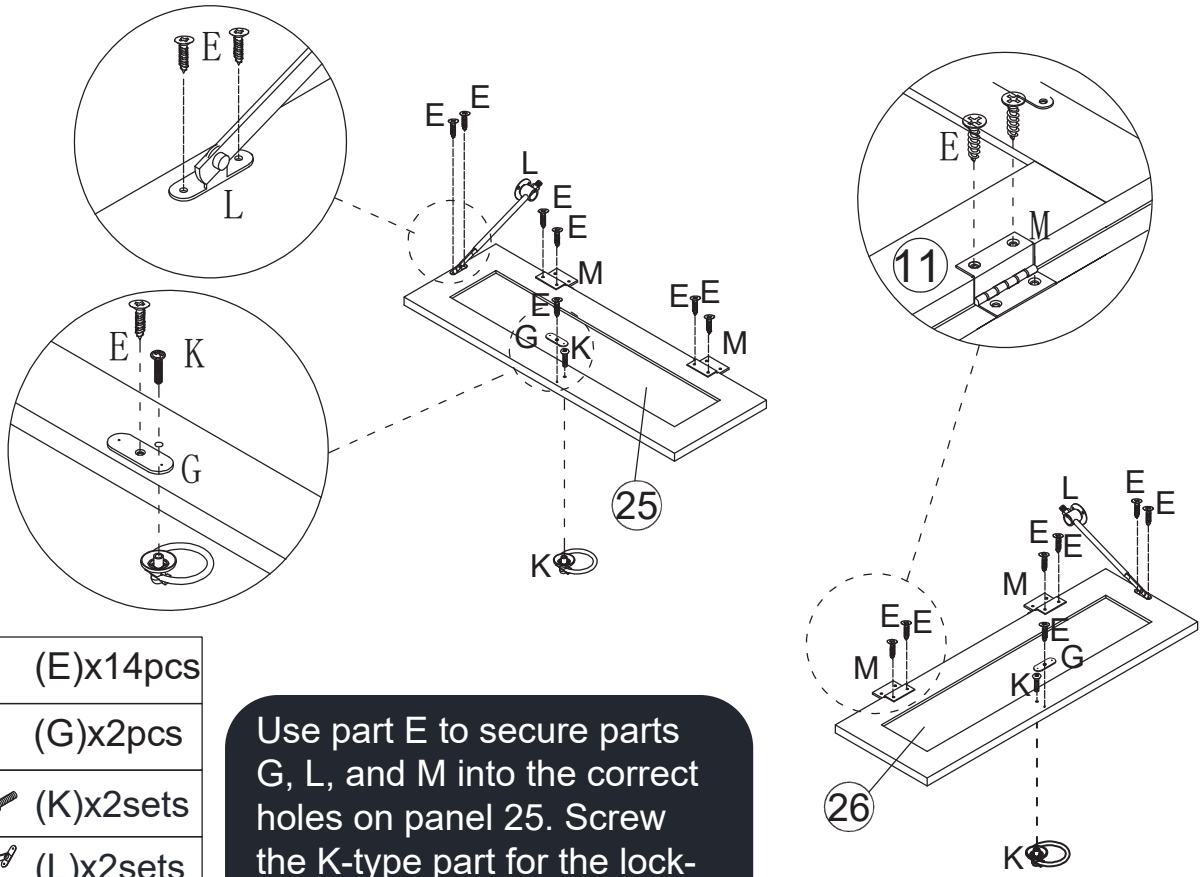

(T)x31pcs

25





-  (E)x14pcs
-  (G)x2pcs
-  (K)x2sets
-  (L)x2sets
-  (M)x4pcs

Use part E to secure parts G, L, and M into the correct holes on panel 25. Screw the K-type part for the locking ring into the correct hole.

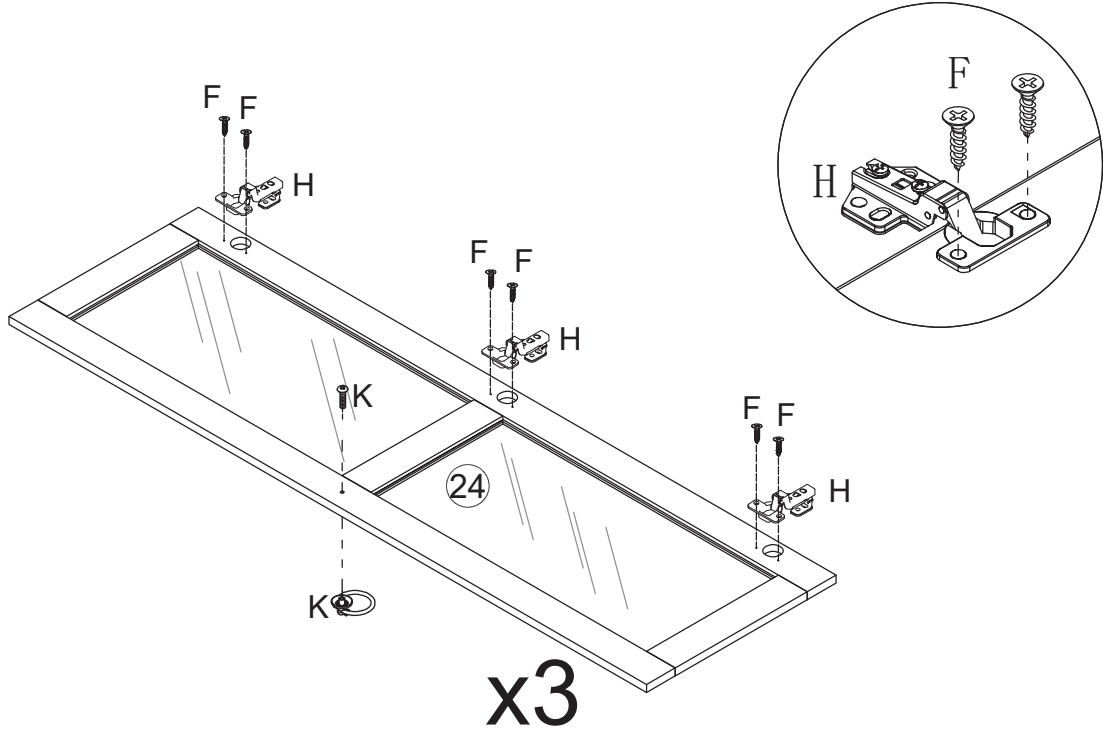
26



-  (F)x18pcs
-  (H)x9pcs
-  (K)x3sets

Secure part H to the #24 panel using F.

27

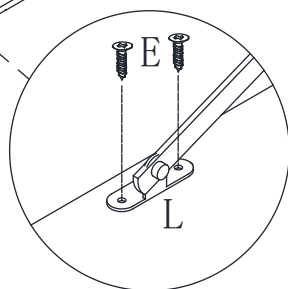
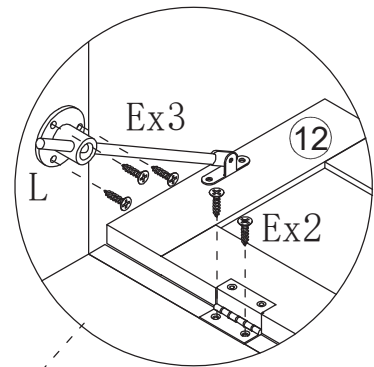
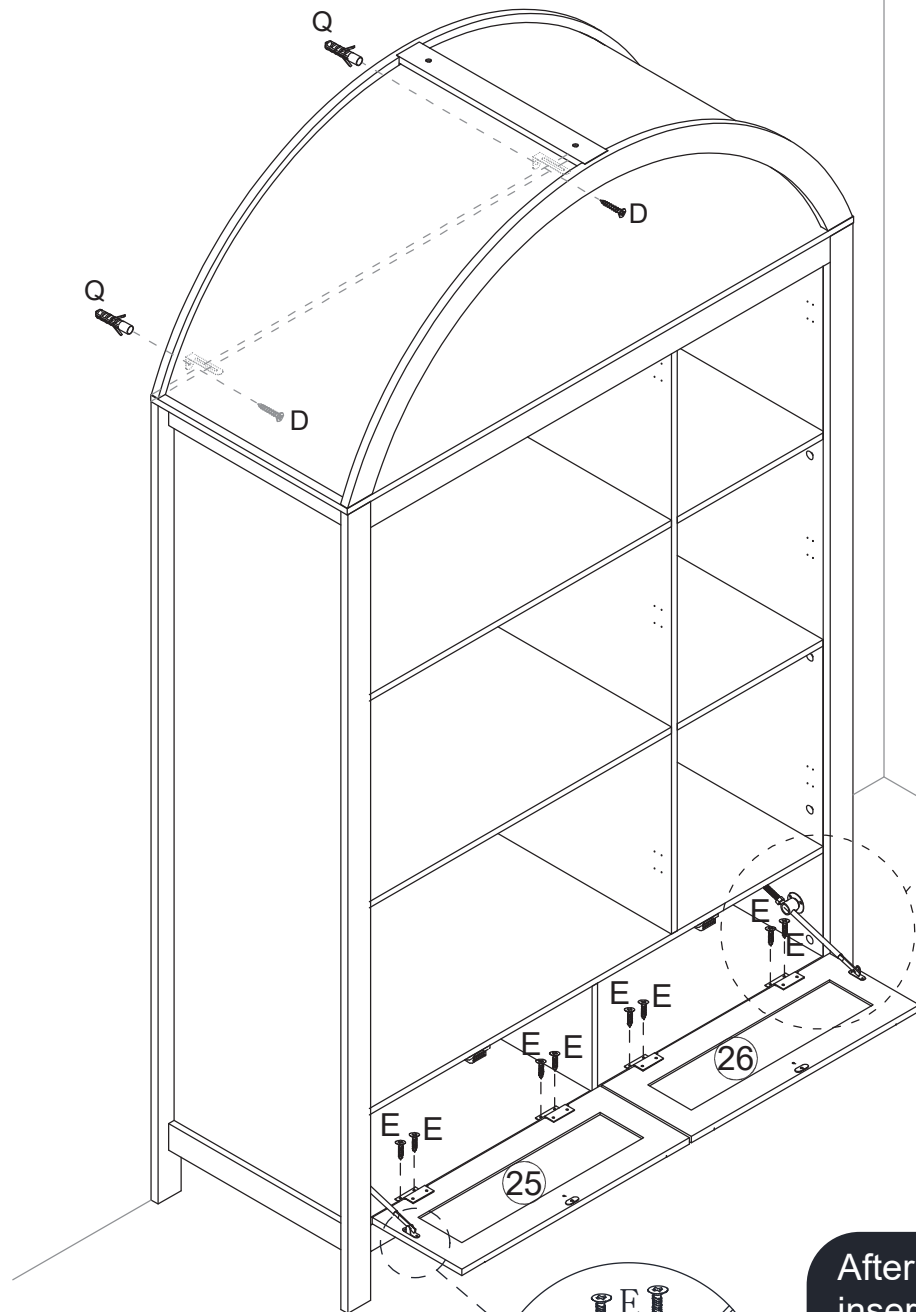
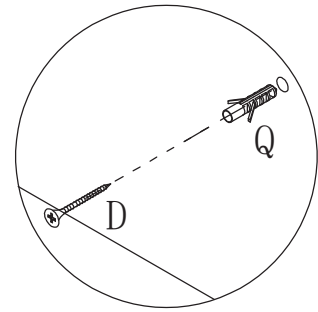
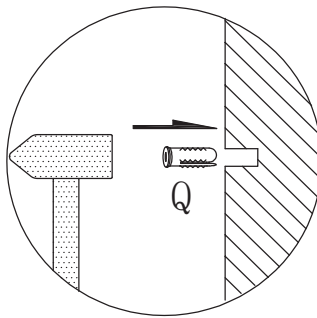
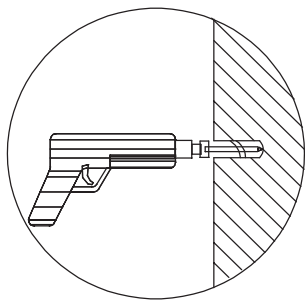

	(D)x2pcs
	(E)x14pcs
	(Q)x2pcs

After drilling a hole in the wall, insert part Q into the hole and secure it with part D. Align the L part with the pre-drilled holes and secure it with the E part.

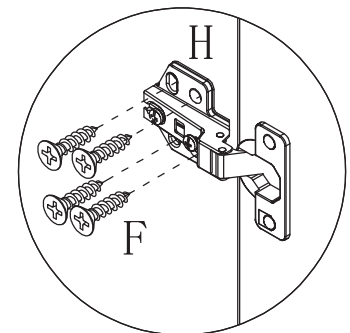
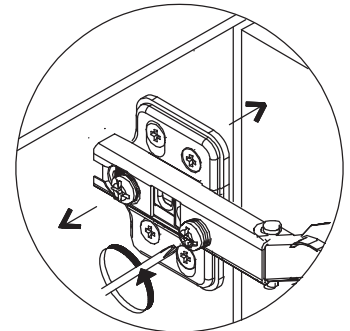
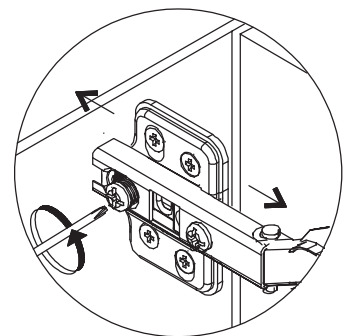
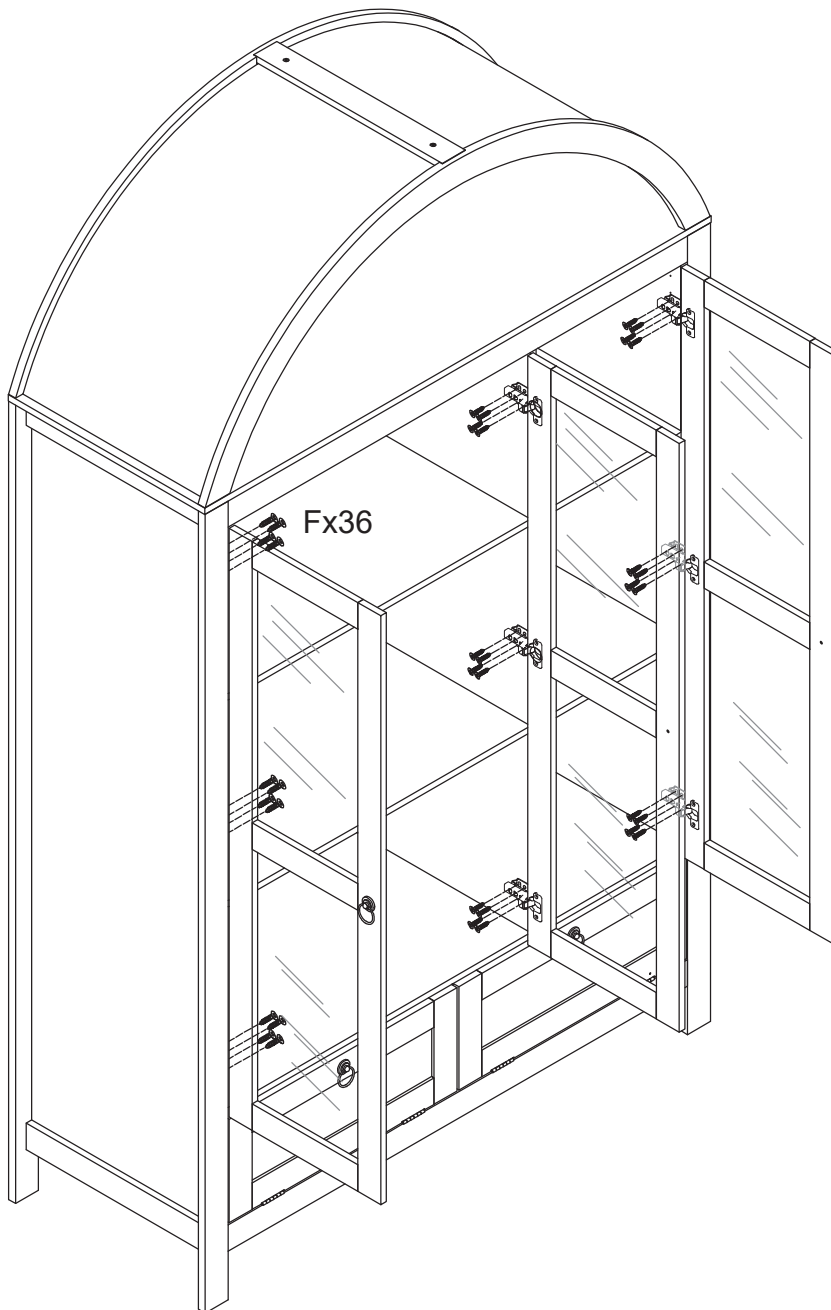

Secure the part H inside the arch cabinet using the part F. After completion, tighten the screws on the H part.



(F)x36pcs

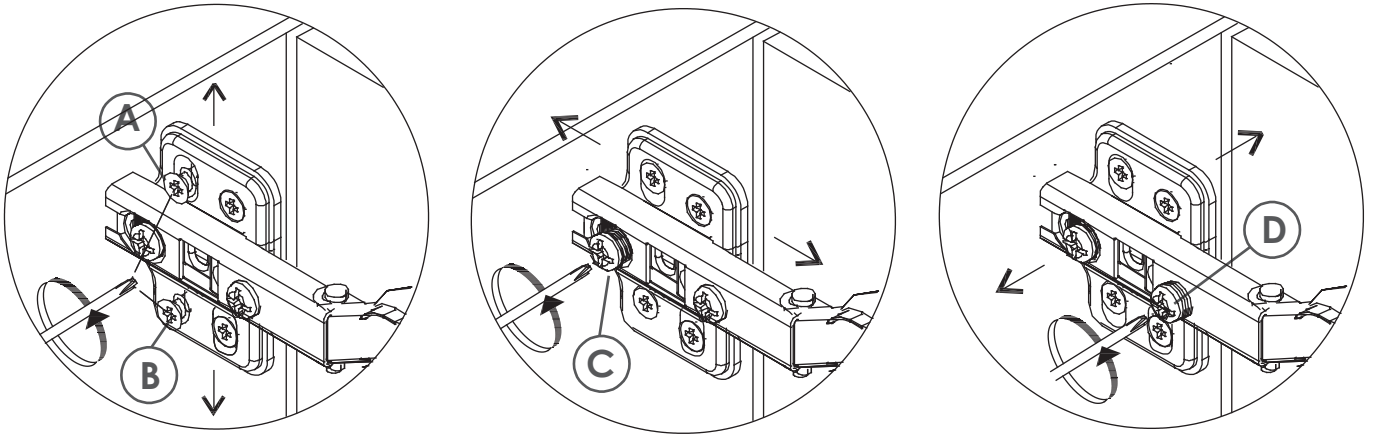

First Diagram

Adjusting Vertical Door Gaps

Scenario 1: Large top gap. Loosen screw A or B , pull door up, then tighten clockwise.

Scenario 2: Large bottom gap. Loosen screw A or B ,counter clockwise, pull door down to fit, then tighten.

Second Diagram:

Aligning Door with Edge

Scenario 1: Door edge inside cabinet. Loosen screw C counterclockwise, move door out to fit, then tighten.

Scenario 2: Door edge beyond cabinet. Loosen screw C, move door in to align, then tighten clockwise.

Third Diagram:

Adjusting Gap Between Two Doors

Case 1: Gap too wide. Tighten screw D clockwise to narrow gap.

Case 2: Gap too narrow. Loosen screw D counterclockwise to widen gap.

