

Shoe cabinet / Cabinet à chaussures

Assembly Instructions - Please keep for future reference

Instructions d'assemblage - s'il vous plaît garder pour référence future

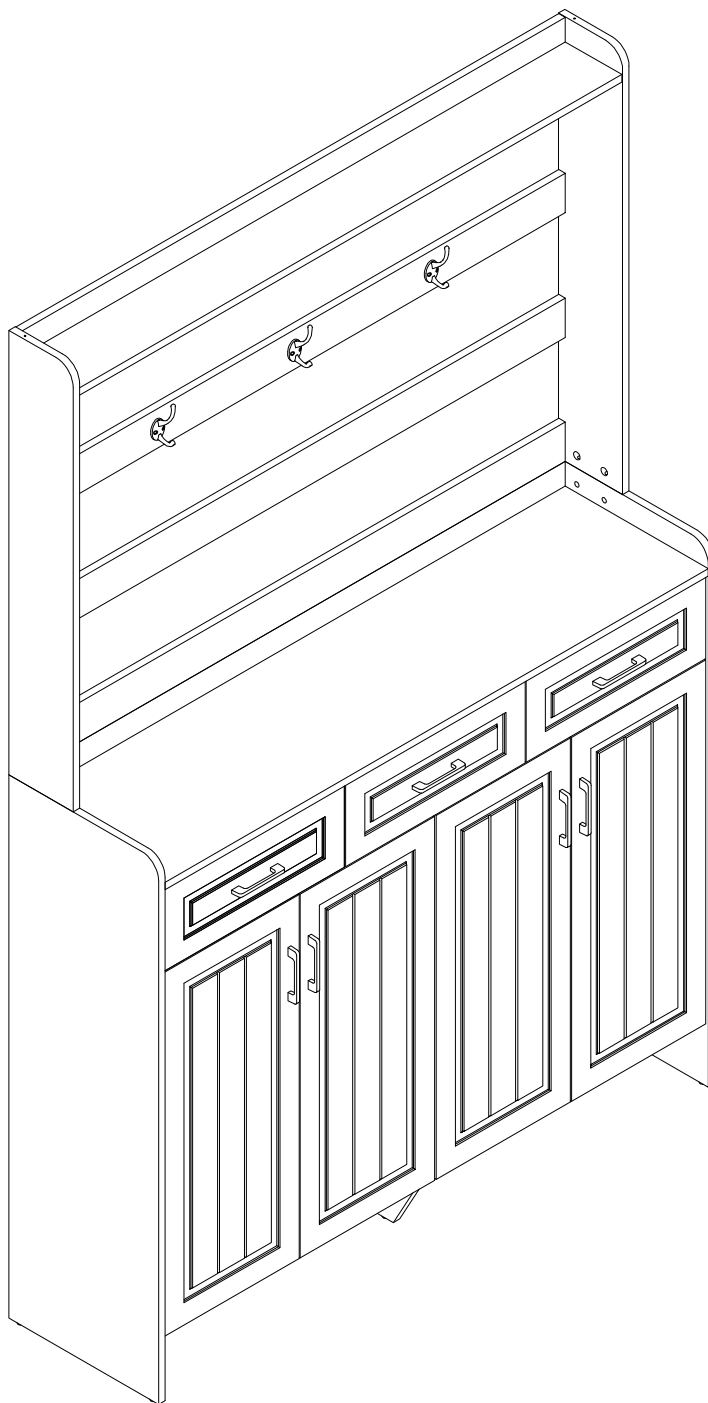

Important – Please read these instructions fully before starting assembly

Important - veuillez lire ces instructions complètement avant de commencer l'assemblage

Safety and Care Advice

Important – Please read these instructions fully before starting assembly

- Check you have all the components and tools listed on the following pages.
- Remove all fittings from the plastic bags and separate them
- Keep children and pets away from the installation area, which may cause choking if small parts are swallowed.
- Make sure you have enough space to layout the parts before

- Do not stand or apply weight to the product during assembly. This may cause damage.
- Assemble the item as close to its final position (in the same room) as possible.
- Assemble on a soft level surface to avoid damage to the unit or floor.
- It's easier for two people to assemble the parts together.



- To reduce the likelihood of damage to your product, make sure your power drill is set to a low torque setting.

Care and maintenance

- Only clean using a damp cloth and mild detergent, do not use bleach or abrasive cleaners.
- Check for loose screws on this unit from time to time.
- This product should not be discarded with household waste. Take to your local authority waste disposal centre.

Handy Hints

- Assemble all parts and bolts loosely during assembly, only once the product is complete should you fully tighten the bolts
- Regularly check and ensure that all bolts and fittings are correctly tightened.

WARNING In order to help prevent overturning – please follow these instructions

To help prevent product toppling over please follow the below steps:-

Use the anti tip stap or wall fixing method provided (if applicable)
Do not allow children to climb or hang on the furniture
Do not open more than one drawer at a time
Do not place heavy items in the top drawers
Do not place heavy items on top of the furniture, unless the furniture has been designed for this purpose

please note that only the anti tip strap is provided.
You will need to provide wall plugs and screws applicable for your wall type

Conseils de sécurité et de soins

Important - veuillez lire ces instructions complètement avant de commencer l'assemblage

- Vérifiez que vous avez tous les composants et outils énumérés sur les pages suivantes.
- Retirez tous les accessoires des sacs en plastique et les séparez
- Gardez les enfants et les animaux de compagnie loin de la zone d'installation, qui peut causer l'étouffement si de petites pièces sont avalées.
- Assurez-vous d'avoir suffisamment d'espace pour mettre en page les pièces avant.
- Ne pas se tenir debout ou appliquer le poids à Le produit pendant l'assemblage. Cela peut causer des dommages.
- Assemblez l'élément le plus près possible de sa position finale (dans la salle de sameroom).
- Assemblez sur un niveau doux Surface pour éviter les dommages À l'unité ou à l'étage.
- Il est plus facile pour deux personnes de se réunir Les parties ensemble.
- Pour réduire la probabilité De dommages à votre produit, Assurez-vous que votre perceuse électrique Est réglé sur un réglage de couple faible.



Entretien et entretien

- Nettoyer uniquement à l'aide d'un détergent doux à linge humide, ne pas utiliser d'eau de javel ou de nettoyeurs abrasifs
- Vérifiez les vis desserrées sur Cette unité de temps en temps.
- Ce produit ne doit pas être jeté avec les ordures ménagères emporter au centre d'élimination des déchets de votre collectivité locale

Conseils pratiques

- Assemblez toutes les pièces et boltsloosely pendant l'assemblée, onlyonce que le produit est completeshould vous serrez entièrement les boulons
- Vérifier et assurer régulièrement Que tous les boulons et raccords sont Correctement serré.

Avertissement Afin de prévenir le renversement Veuillez suivre ces instructions

Pour aider à prévenir le renversement du produit, veuillez suivre les étapes suivantes :-

Utilisez la méthode anti-tip stap ou de fixation murale fournie (le cas échéant)
Ne laissez pas les enfants grimper ou accrocher aux meubles
N'ouvrez pas plus d'un tiroir à la fois
Ne placez pas d'objets lourds dans les tiroirs supérieurs
Ne placez pas d'objets lourds sur le dessus des meubles, sauf si les meubles ont été Conçu à cet effet

Veuillez noter que seule la courroie anti-pointe est fournie.

Vous devrez fournir des bouchons muraux et des vis applicables pour votre type de mur

Using Camlocks

Step 1

Connect the male camlock as directed in the assembly instructions using a screwdriver.

1 DO NOT OVER TIGHTEN.

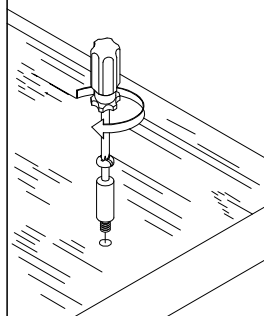

Step 2

Push the male camlock into the entry hole.

2

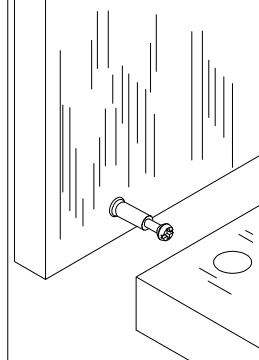

Step 3

Insert the female camlock as shown in the instruction.

Note: ensure that the arrow on the top of the camlock points towards the entry hole for the male camlock.

3

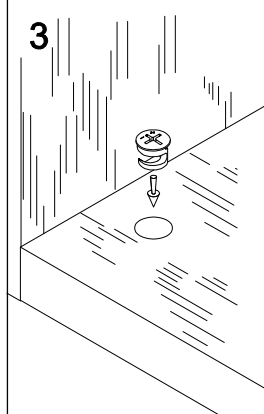

Step 4

Turn the female camlock clockwise with a screwdriver.

You should feel a click when the camlock is locked in place.

The joint is now secure.

4

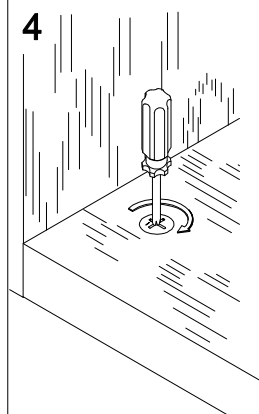

Utilisation de Camlocks

1

Connectez le mâle Camlock tel que dicté dans Les instructions de montage Utiliser un driver scwdriver.

1

Ne pas trop serrer.
NE PAS SERRER EXCESSIVEMENT.

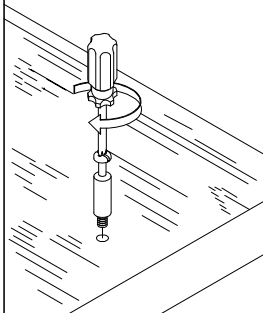

2

Poussez le camlock mâle Dans le trou d'entrée.

2

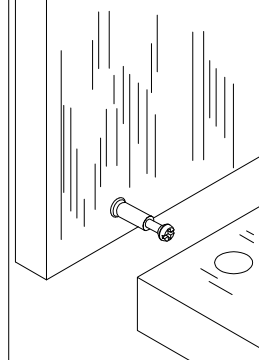

3

Insérer le femelle Camlock comme indiqué dans le Instruction.

Note: assurez-vous que le Flèche sur le haut de la Camlock pointe vers Le trou d'entrée pour la Mâle camlock.

3

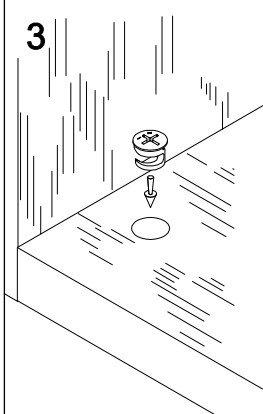

4

Tournez la femelle camlock Dans le sens horaire avec un Tournevis.

Vous devriez sentir un clic Lorsque le camlock est Verrouillé en place.

Le joint est maintenant sécurisé.

4

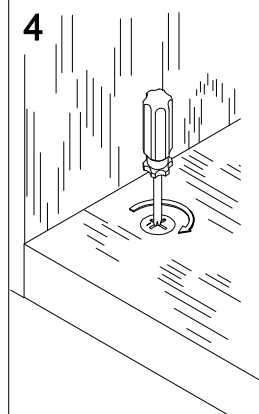



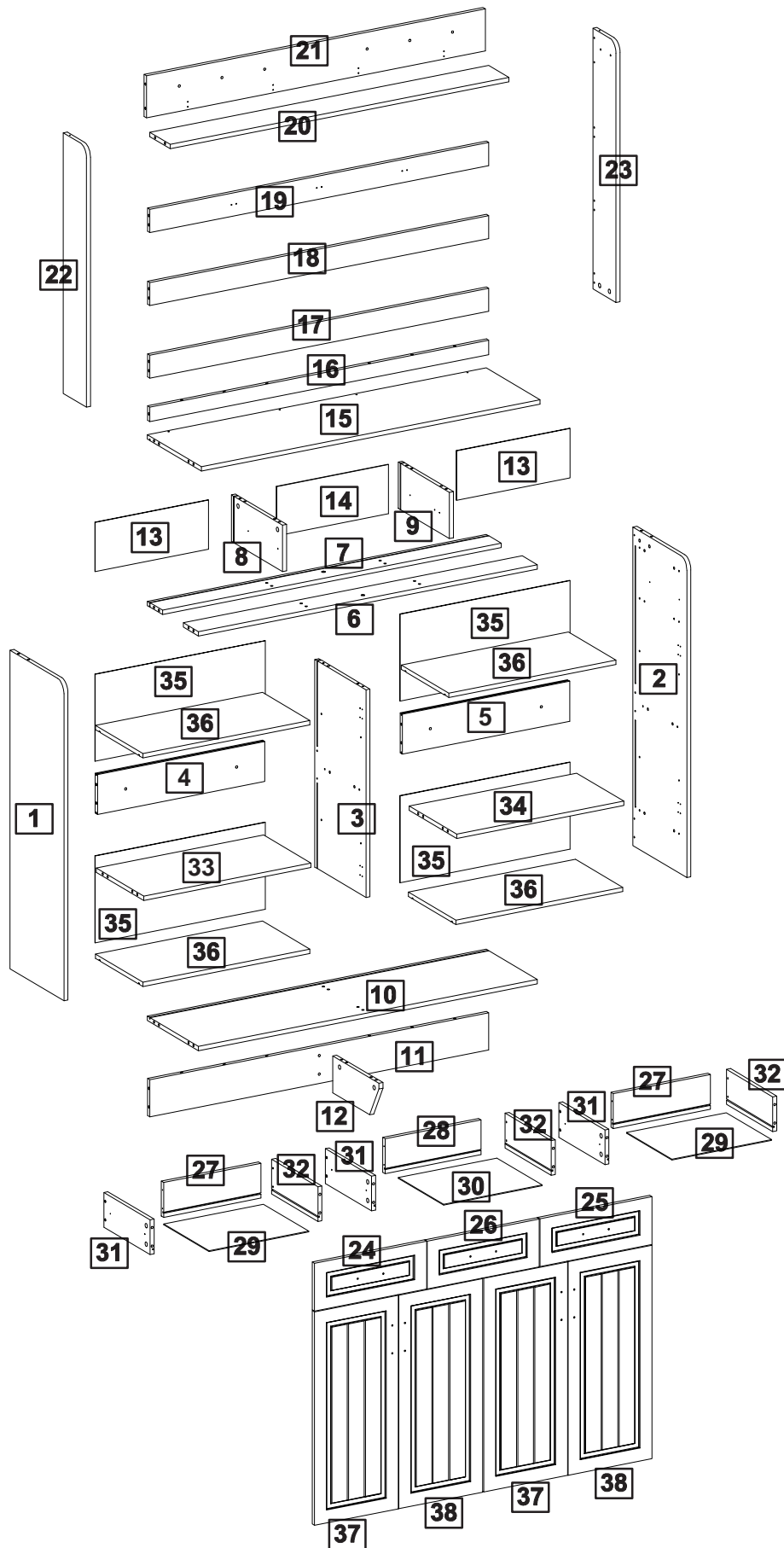

Assembly Instructions / Instructions de montage

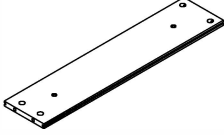
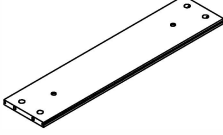
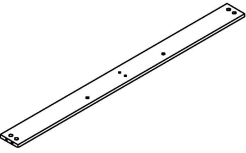
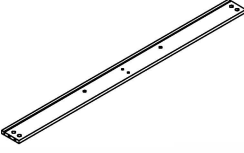
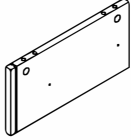
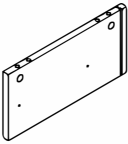
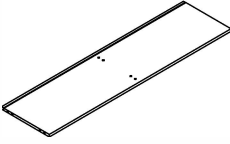
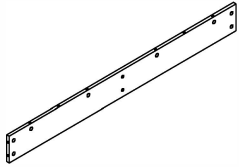
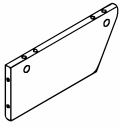
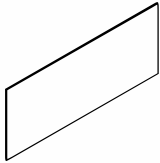
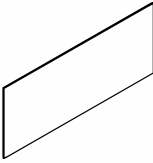
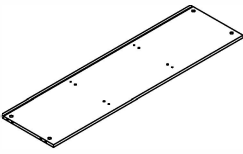
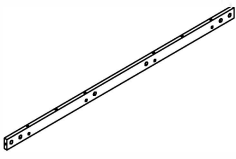
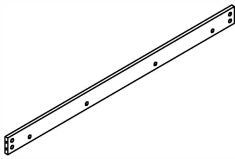
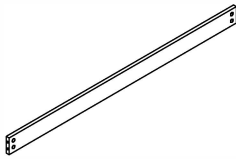
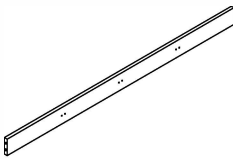
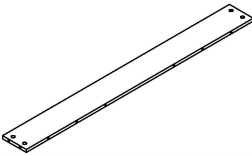
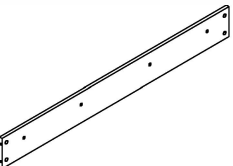

Part List / Liste des pièces

Hardware list / Liste du matériel:

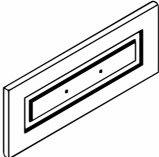
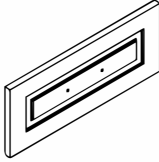
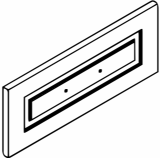
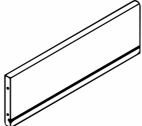
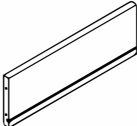
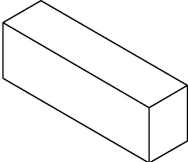





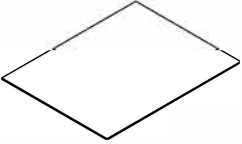
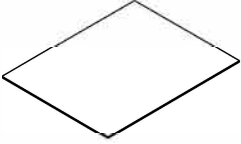
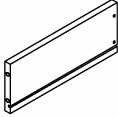
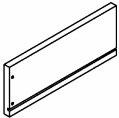
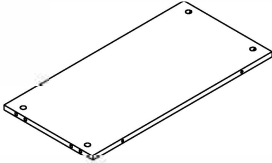
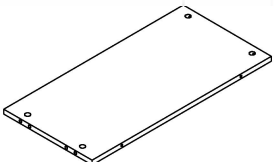
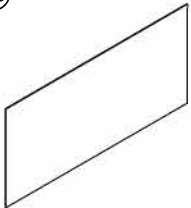
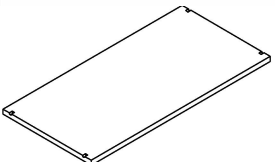
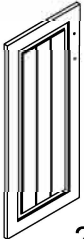
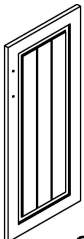







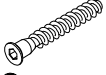



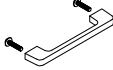

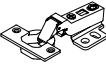
 <p>1 PC</p>	 <p>1 PC</p>	 <p>1 PC</p>	 <p>1 PC</p>	 <p>1 PC</p>
 <p>1 PC</p>	 <p>1 PC</p>	 <p>1 PC</p>	 <p>1 PC</p>	 <p>1 PC</p>
 <p>1 PC</p>	 <p>1 PC</p>	 <p>2 PCS</p>	 <p>1 PC</p>	 <p>1 PC</p>
 <p>1 PC</p>	 <p>1 PC</p>	 <p>1 PC</p>	 <p>1 PC</p>	 <p>1 PC</p>
 <p>1 PC</p>	 <p>1 PC</p>	 <p>1 PC</p>	 <p>1 PC</p>	 <p>1 PC</p>
 <p>1 PC</p>	 <p>2 PCS</p>	 <p>1 PC</p>	 <p>Hardware Matériel informatique 1 PC</p>	

Part List / Liste des pièces

Hardware list / Liste du matériel:

<p>29</p>  <p>2 PCS</p>	<p>30</p>  <p>1 PC</p>	<p>31</p>  <p>3 PCS</p>	<p>32</p>  <p>3 PCS</p>	<p>33</p>  <p>1 PC</p>
<p>34</p>  <p>1 PC</p>	<p>35</p>  <p>4 PCS</p>	<p>36</p>  <p>4 PCS</p>	<p>37</p>  <p>2 PCS</p>	<p>38</p>  <p>2 PCS</p>

Hardware list / Liste du matériel

<p>A  Male Camlock x 84 Mâle Camlock</p>	<p>B  Female Camlock x 92 Femelle Camlock</p>	<p>C  Dowel x 36 Le goujon</p>
<p>D  Drawer slider 12" x 3 Tiroir slider 12"</p>	<p>E  3*14mm Screw x 26 3 *14mm vis</p>	<p>F  6*50mm Screw x 18 6*50mm vis</p>
<p>G  4*30mm Screw x 12 4*30mm vis</p>	<p>H  Shelf Support Pin x16 Pin de Support d'étagère</p>	<p>I  Male Camlock x 8 Mâle Camlock</p>
<p>J  Nut x 8 noix</p>	<p>K  Handle & Fixings x 7 Poignée & fixations</p>	<p>L  Door Hinge x 4 Charnière de porte</p>
<p>M  Door Hinge x 4 Charnière de porte</p>	<p>N  3.5*14mm Screw x 48 3.5 *14mm vis</p>	<p>O  Back Panel Stiffener x 25 Panneau arrière raidisseur</p>
<p>P  Ø20 Sticker x 50 Ø20 autocollant</p>	<p>Q  x 4</p>	<p>R  x 3</p>
<p>S  3*16mm Screw x 14 3*16mm vis</p>	<p>T  Wall Fixing Pack x 2 Paquet de fixation murale</p>	<p>U  Hex Key M4 x 1 Clé hexagonale M4</p>
<p>V  Protective Feet x 8 Pieds de protection</p>		



Assembly Tools Required (Not Included)
Outils d'assemblage requis (Non Inclus)

Assembly Instructions / Instructions de montage

Step 1

Étape 1

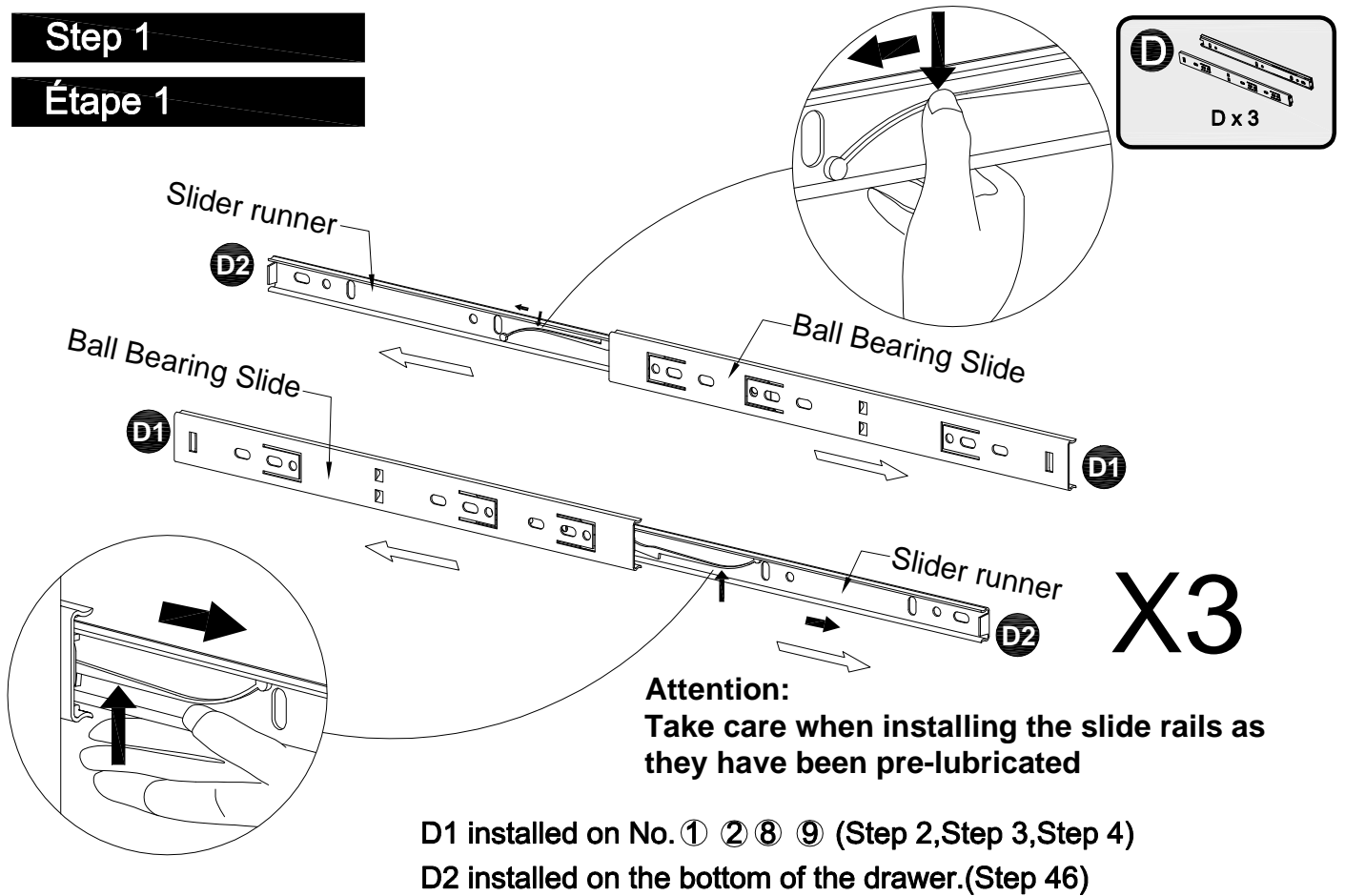

Step 2

Étape 2

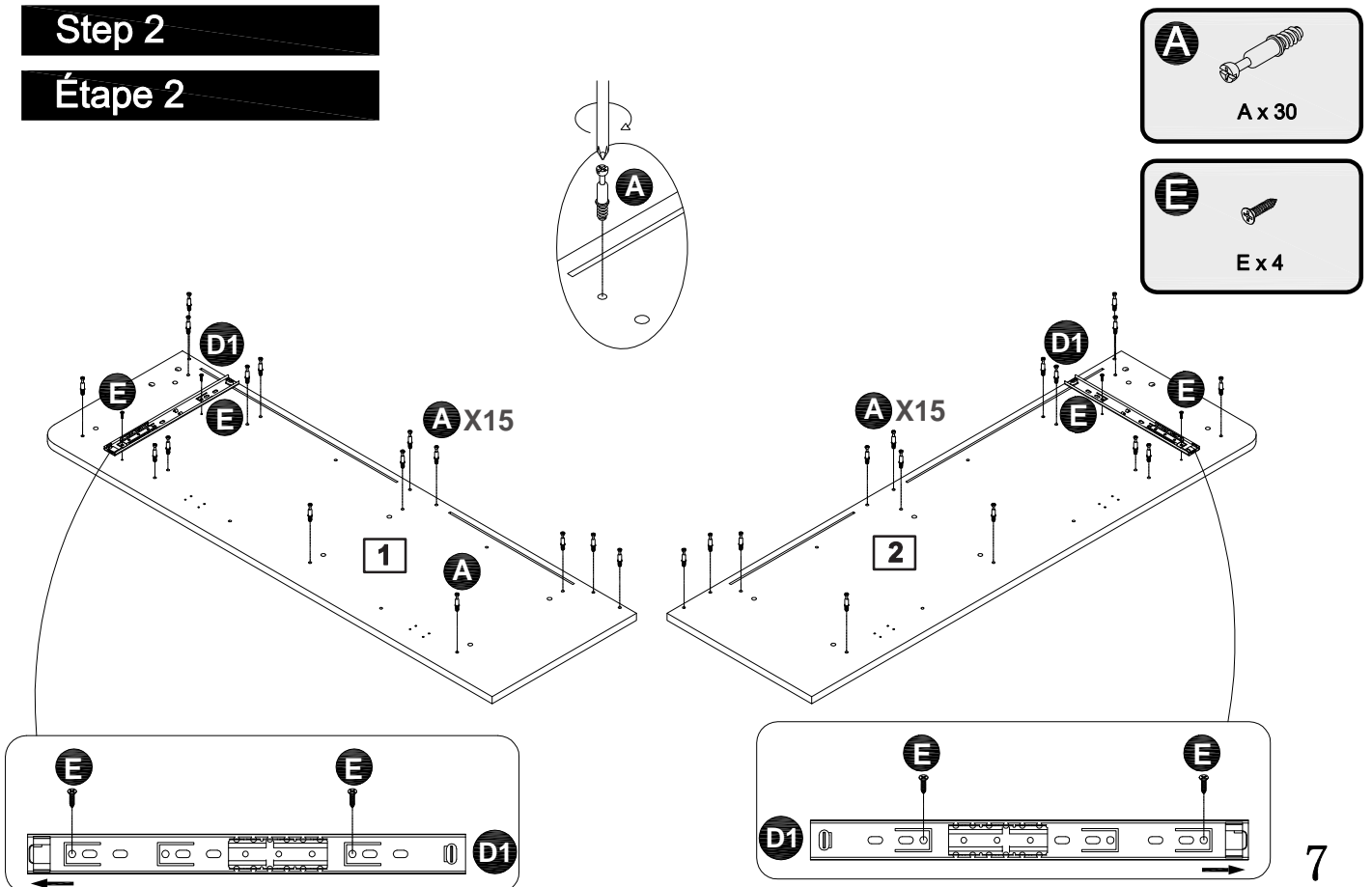

Assembly Instructions / Instructions de montage

Step 3

Étape 3

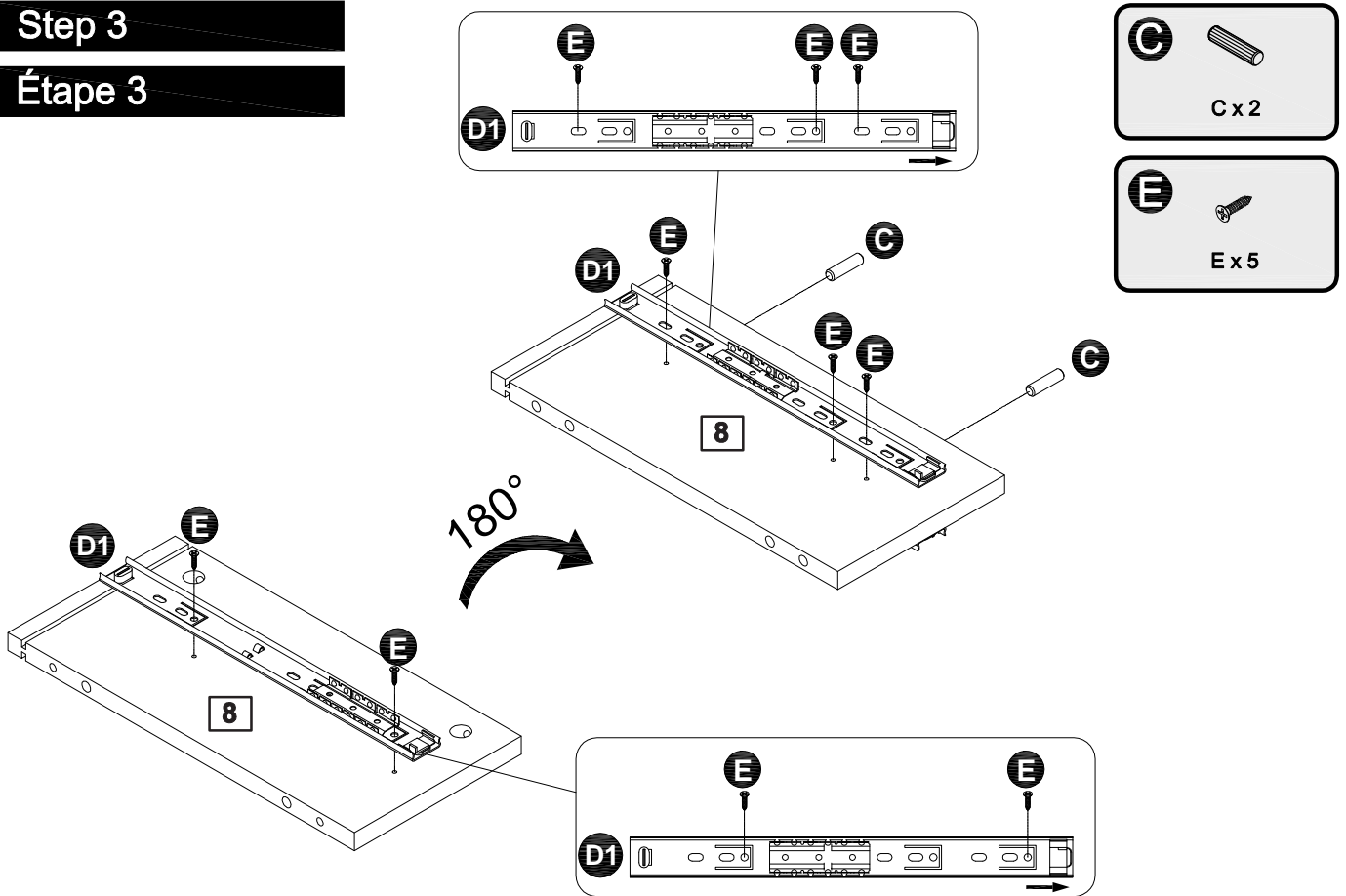

Step 4

Étape 4

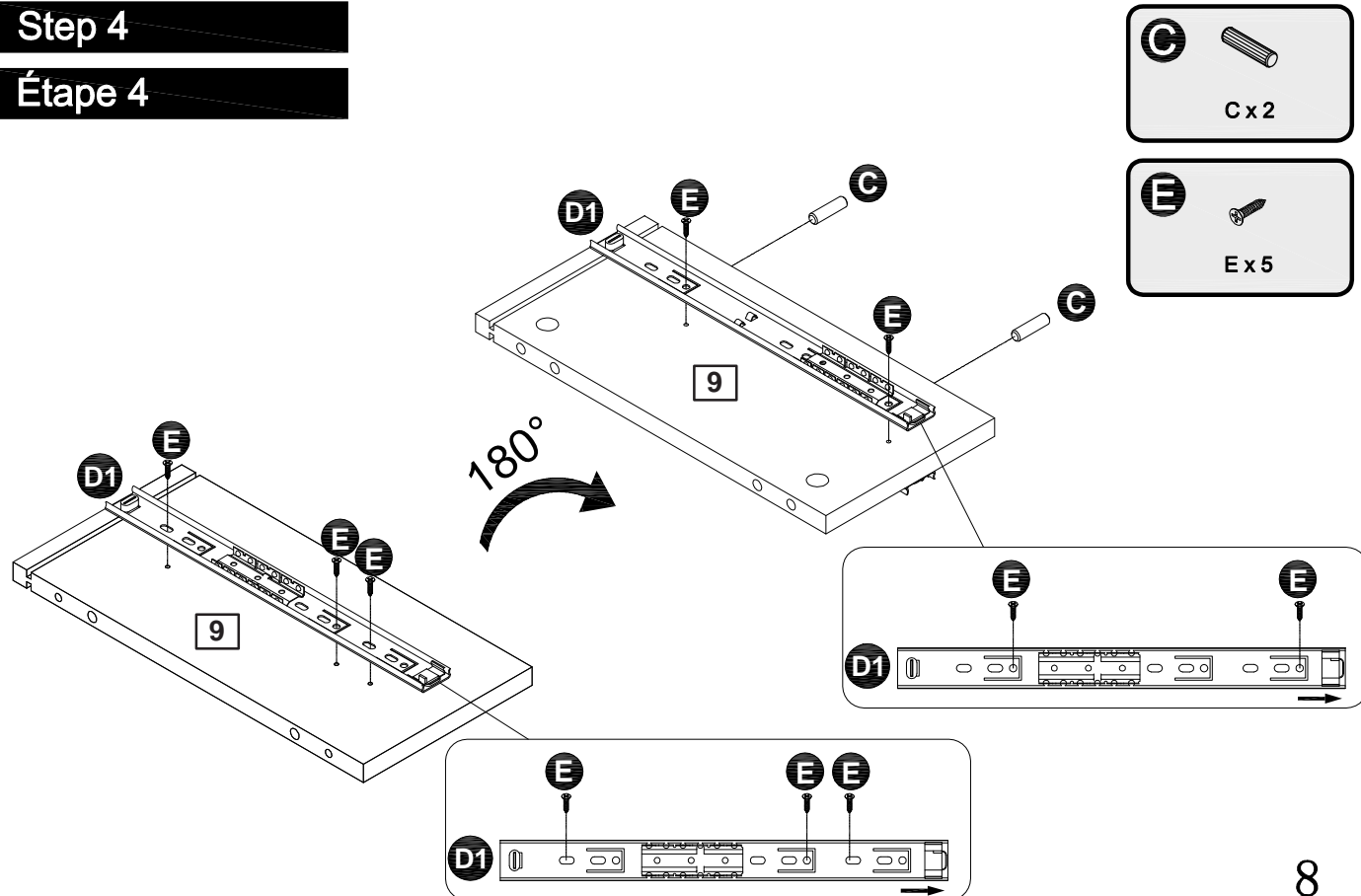

Assembly Instructions / Instructions de montage

Step 5

Étape 5

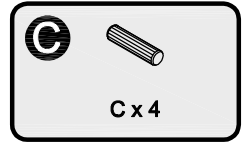
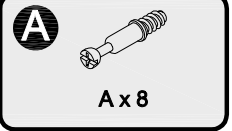
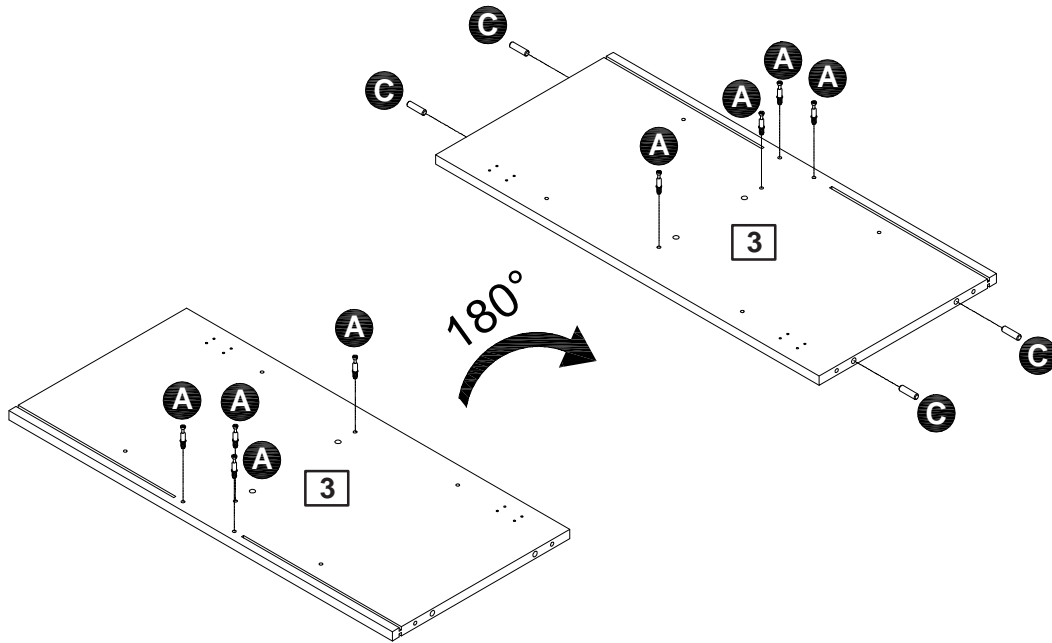

Step 6

Étape 6

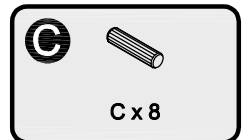
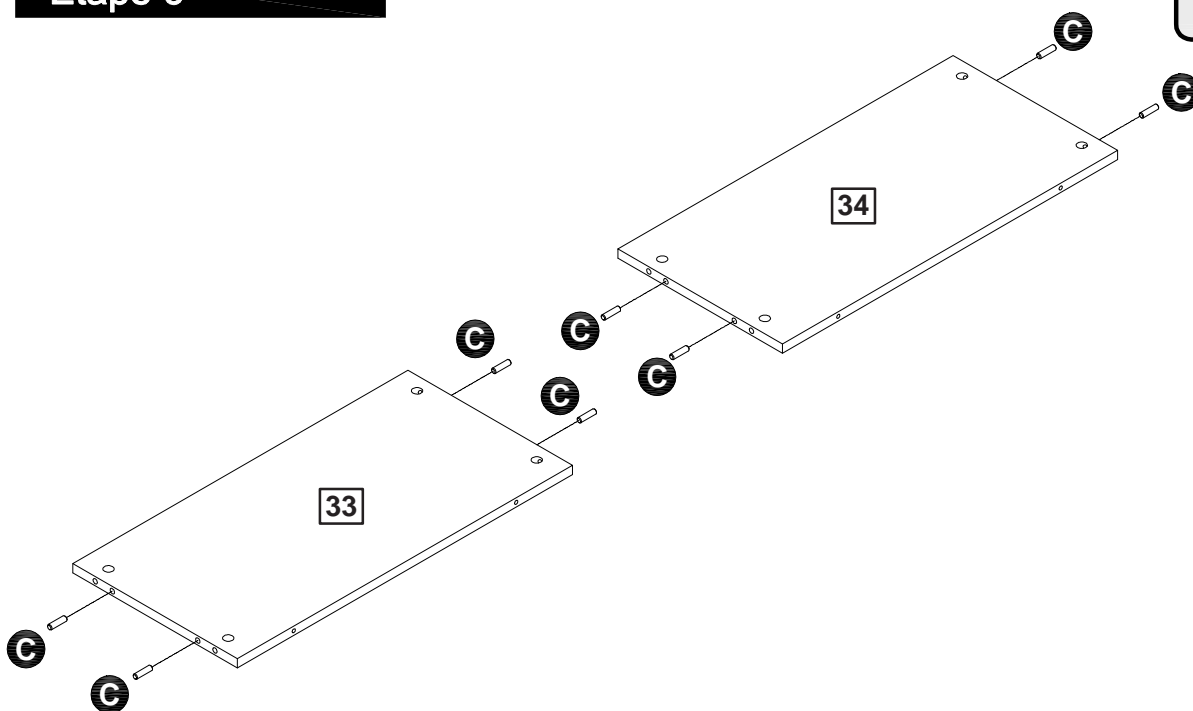

Assembly Instructions / Instructions de montage

Step 7

Étape 7



B x 2

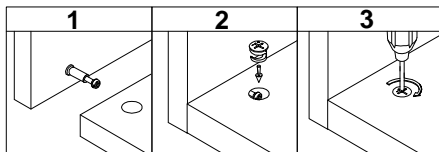
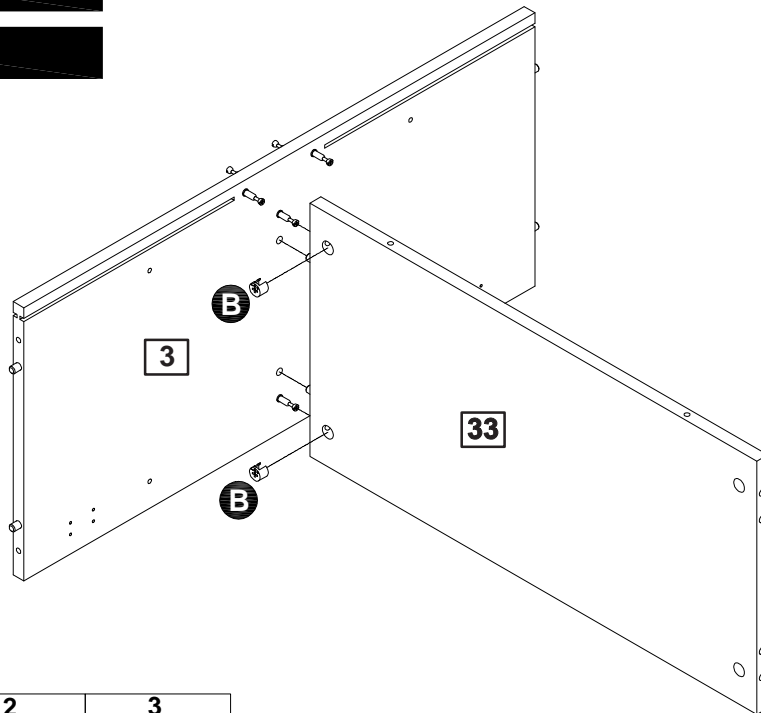

Step 8

Étape 8



B x 2

During the assembly process, please ensure that the cabinet remains stationary and avoid any movement operations.

Pendant le processus d'assemblage, assurez-vous que l'armoire reste stationnaire et évitez toute opération de mouvement.

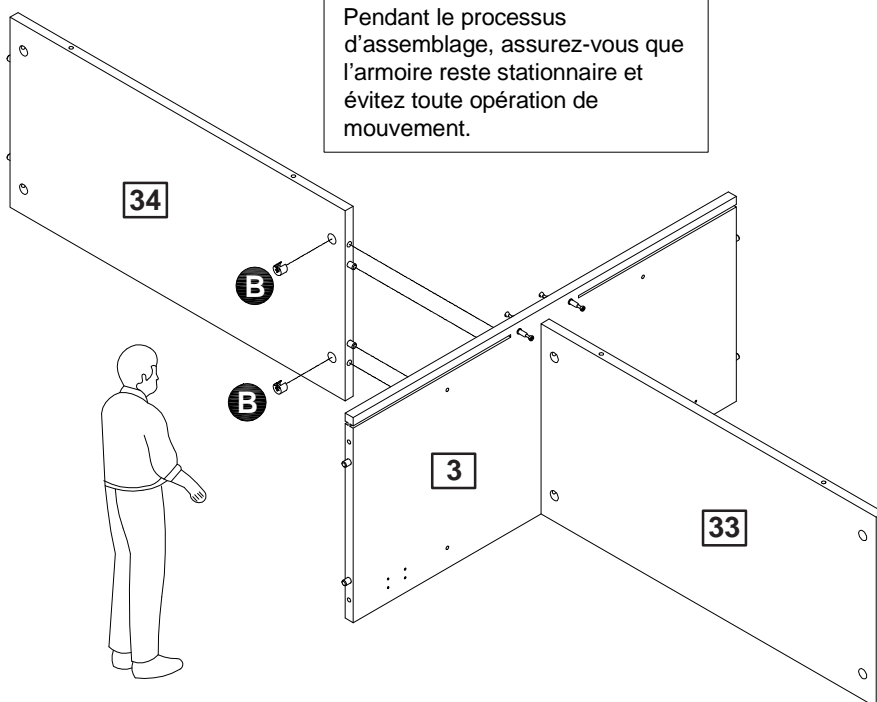

Assembly Instructions / Instructions de montage

Step 9

Étape 9

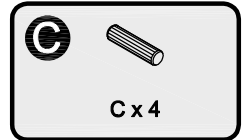
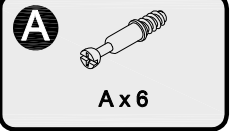
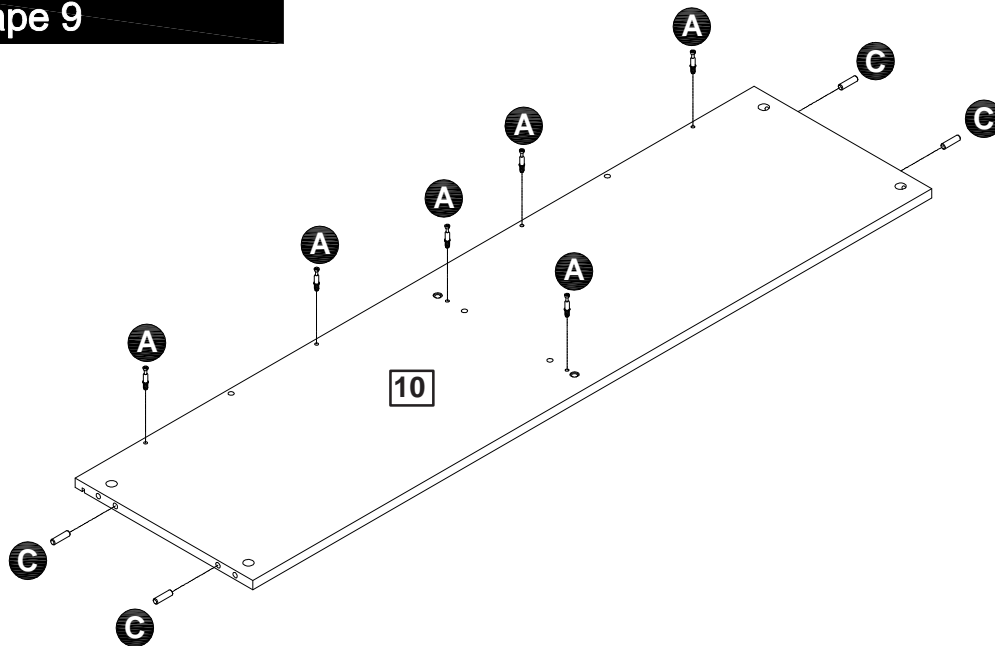

Step 10

Étape 10

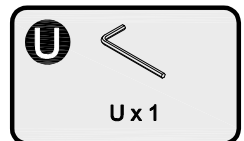
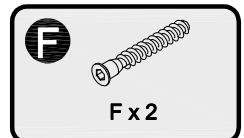
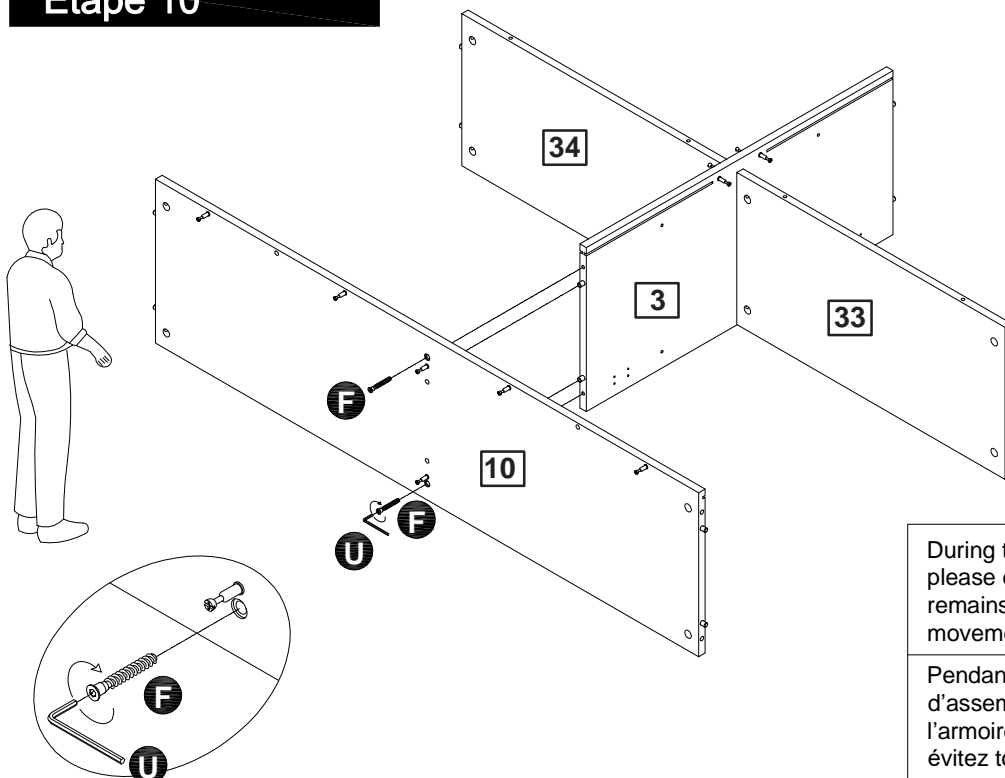

During the assembly process, please ensure that the cabinet remains stationary and avoid any movement operations.

Pendant le processus d'assemblage, assurez-vous que l'armoire reste stationnaire et évitez toute opération de mouvement.

Assembly Instructions / Instructions de montage

Step 11

Étape 11



C x 4

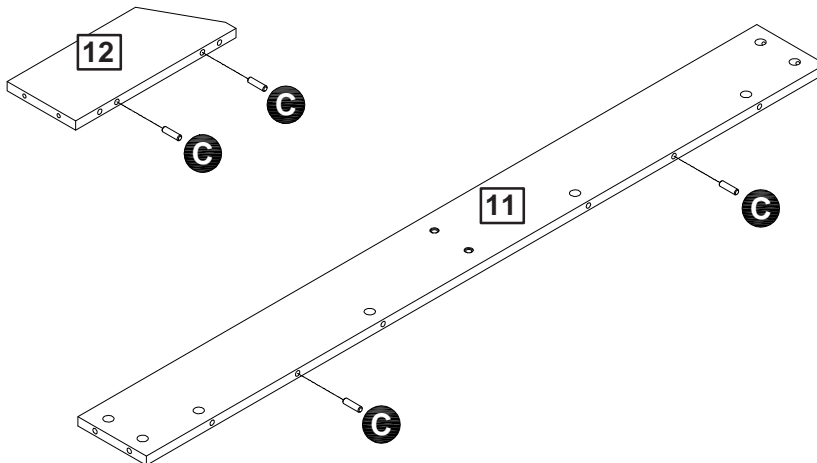

Step 12

Étape 12



F x 2



U x 1

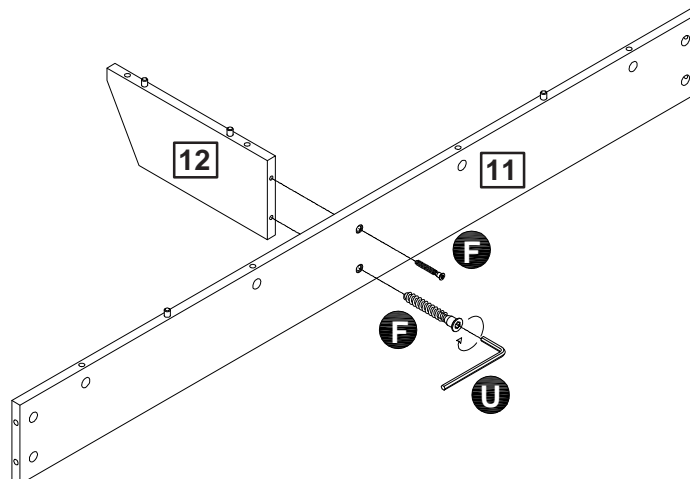

Assembly Instructions / Instructions de montage

Step 13

Étape 13

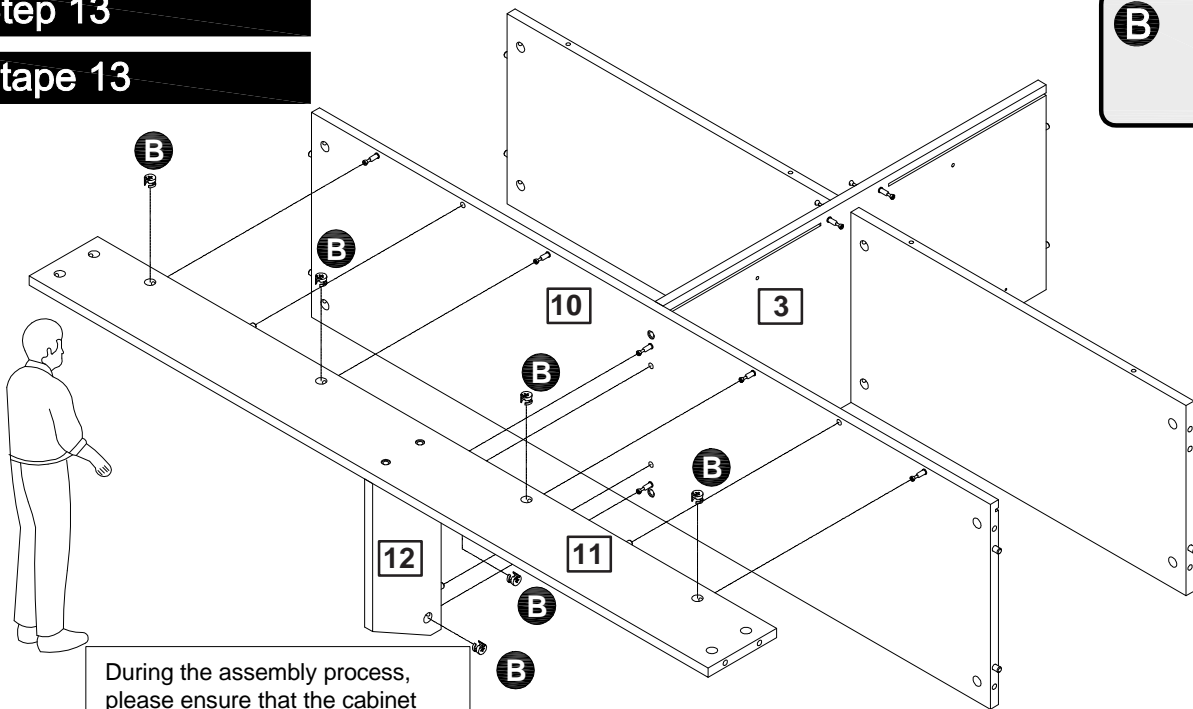

During the assembly process, please ensure that the cabinet remains stationary and avoid any movement operations.

Pendant le processus d'assemblage, assurez-vous que l'armoire reste stationnaire et évitez toute opération de mouvement.

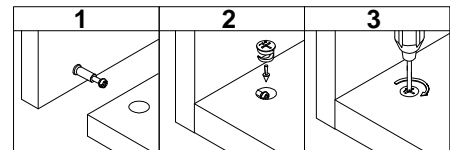

Step 14

Étape 14

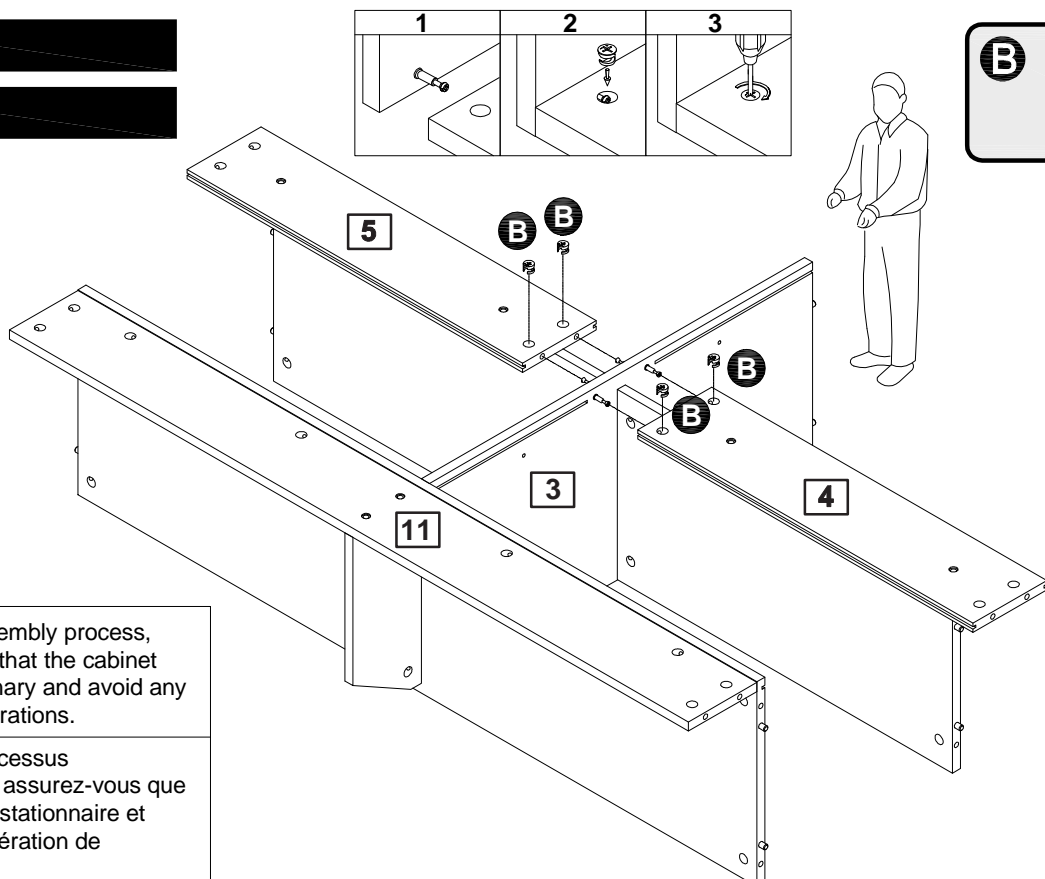

During the assembly process, please ensure that the cabinet remains stationary and avoid any movement operations.

Pendant le processus d'assemblage, assurez-vous que l'armoire reste stationnaire et évitez toute opération de mouvement.

Assembly Instructions / Instructions de montage

Step 15

Étape 15

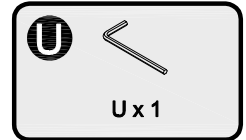
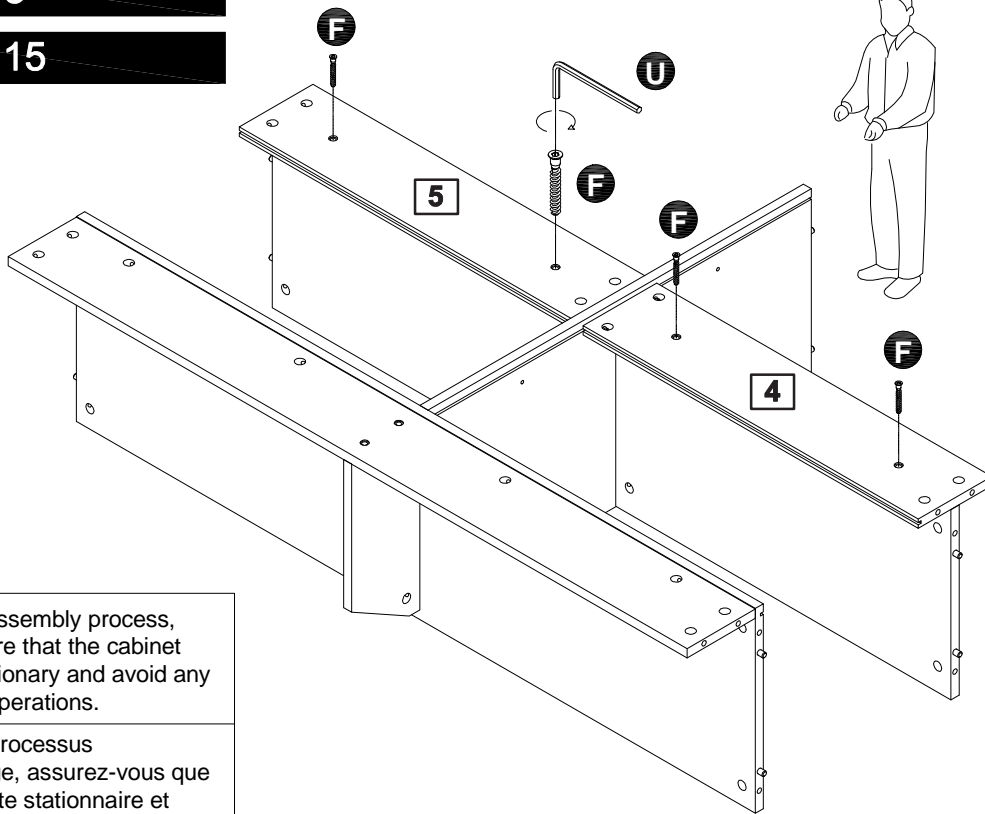

During the assembly process, please ensure that the cabinet remains stationary and avoid any movement operations.

Pendant le processus d'assemblage, assurez-vous que l'armoire reste stationnaire et évitez toute opération de mouvement.

Step 16

Étape 16

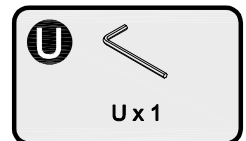
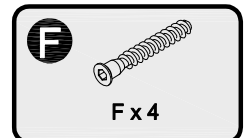
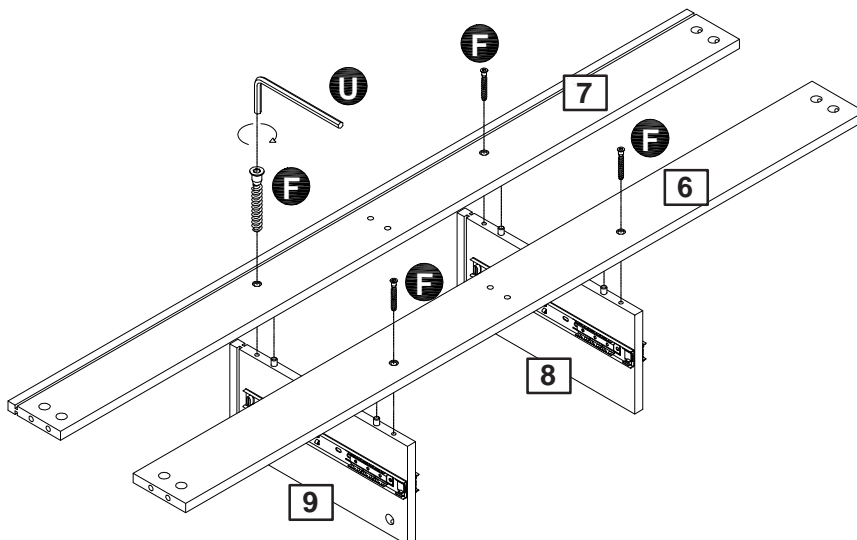

Assembly Instructions / Instructions de montage

Step 17

Étape 17

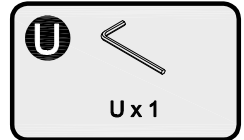
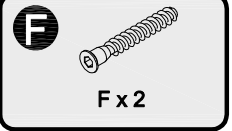
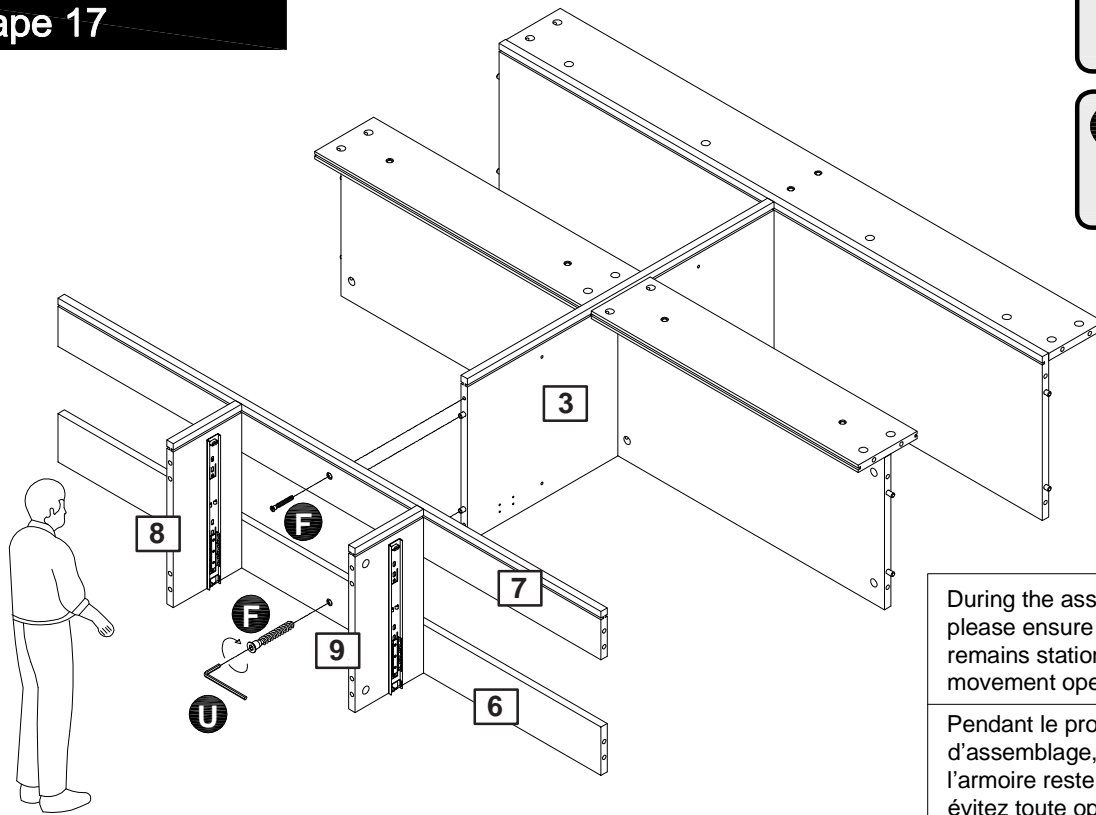

During the assembly process, please ensure that the cabinet remains stationary and avoid any movement operations.

Pendant le processus d'assemblage, assurez-vous que l'armoire reste stationnaire et évitez toute opération de mouvement.

Step 18

Étape 18

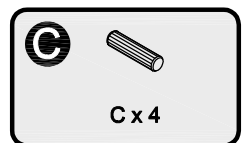
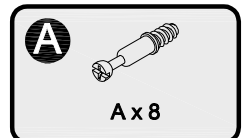
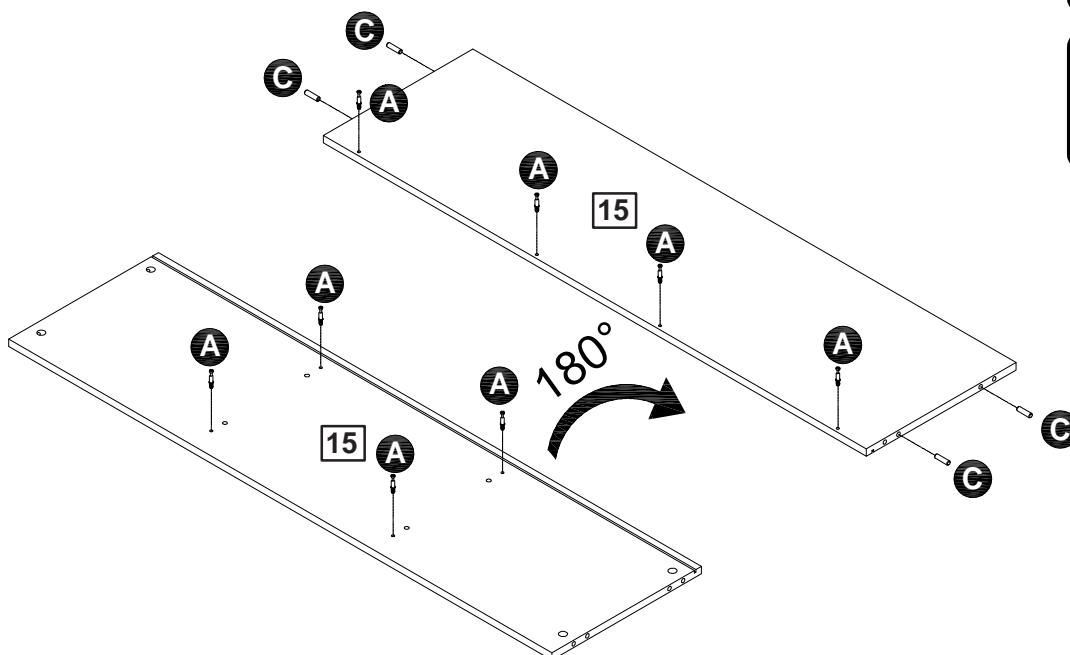

Assembly Instructions / Instructions de montage

Step 19

Étape 19

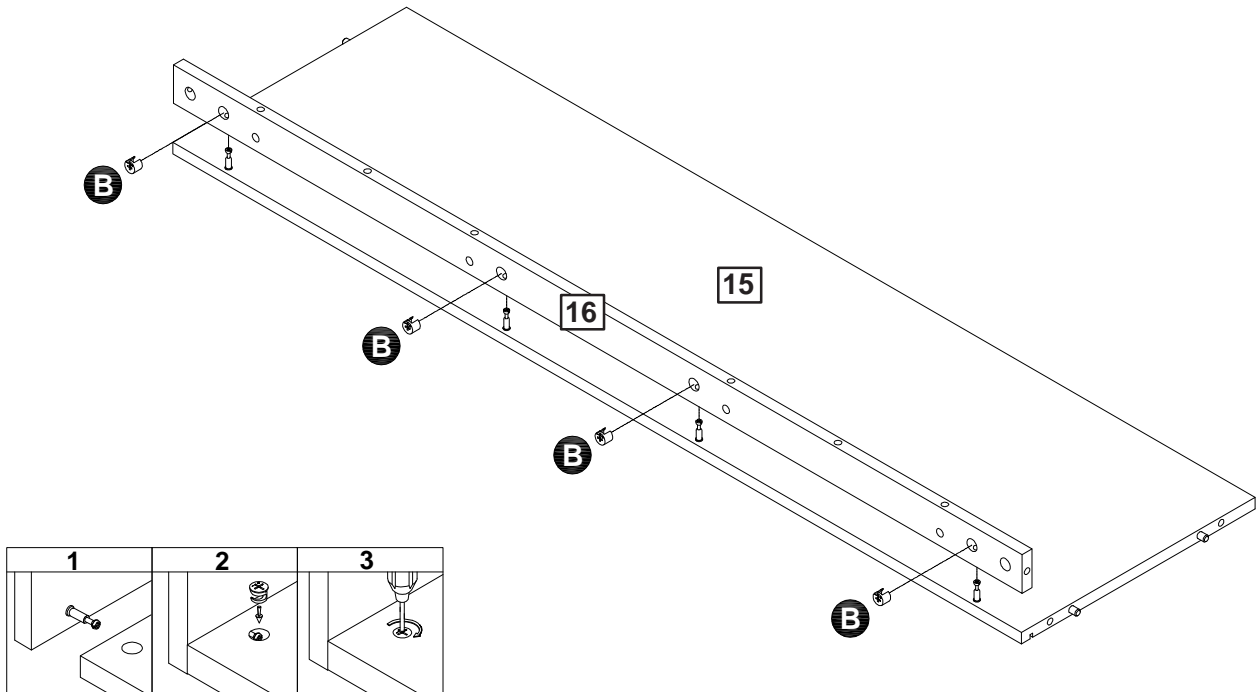

Step 20

Étape 20

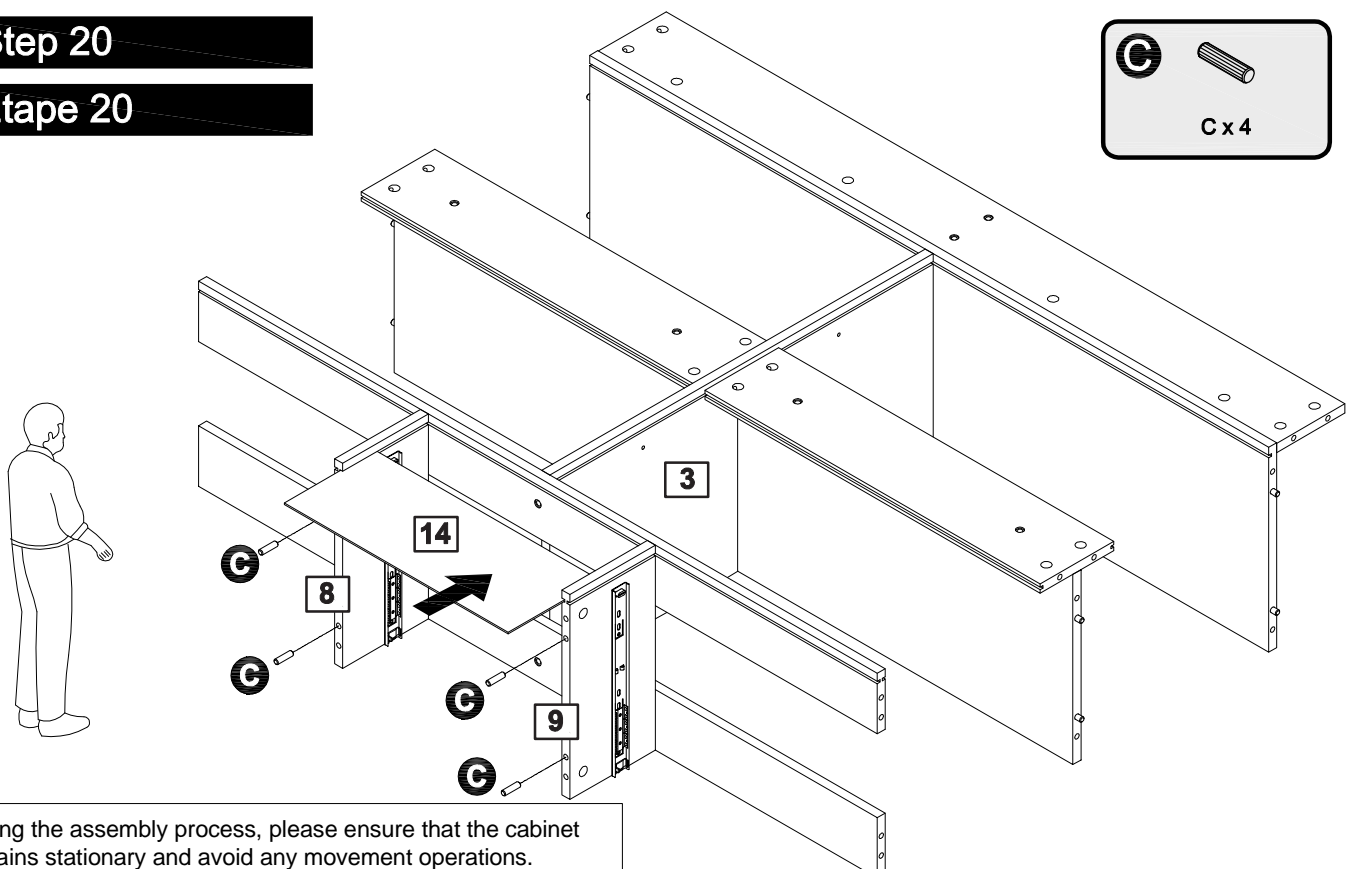
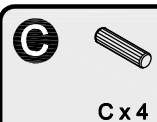

During the assembly process, please ensure that the cabinet remains stationary and avoid any movement operations.

Pendant le processus d'assemblage, assurez-vous que l'armoire reste stationnaire et évitez toute opération de mouvement.

Assembly Instructions / Instructions de montage

Step 21

Étape 21

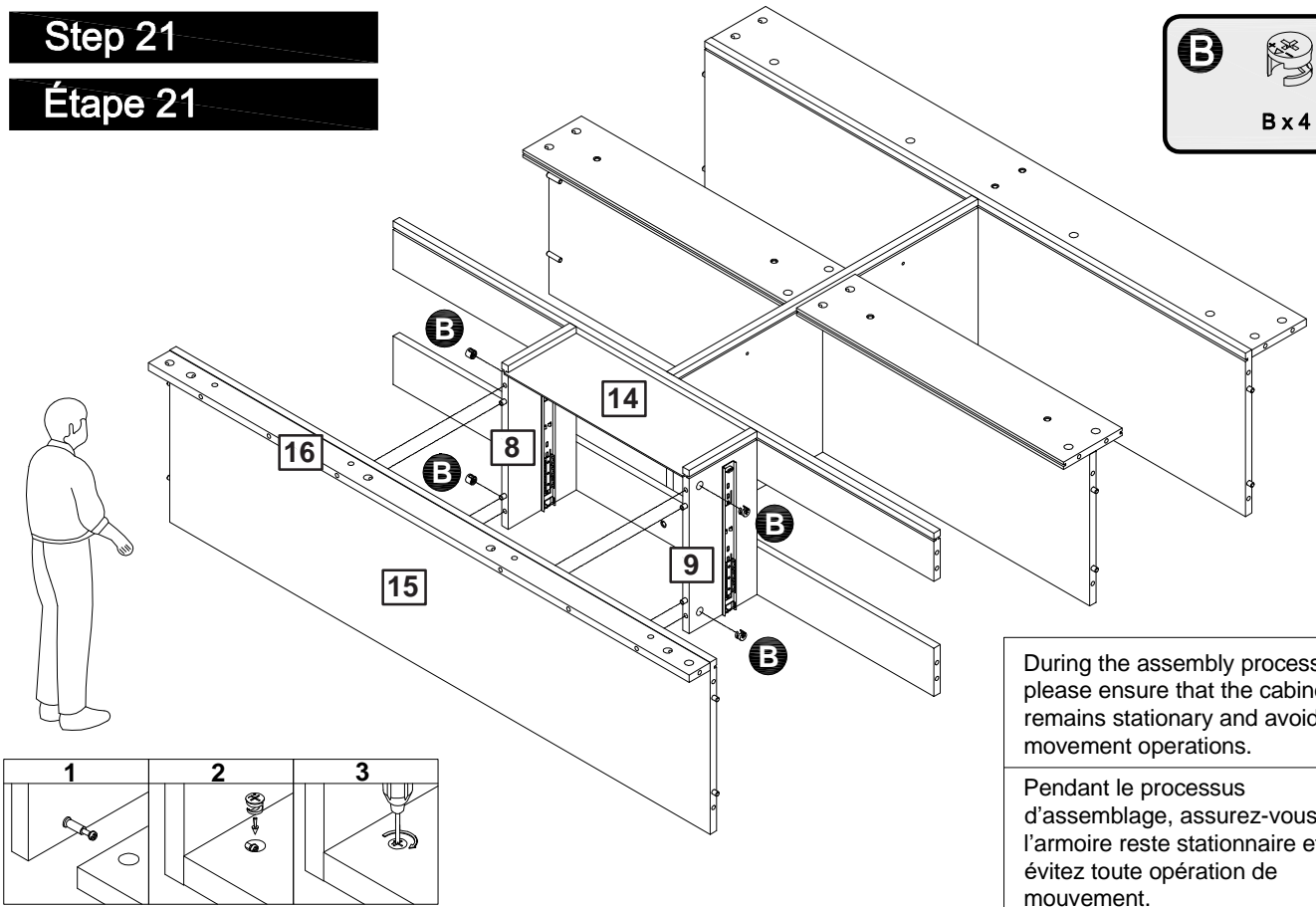

During the assembly process, please ensure that the cabinet remains stationary and avoid any movement operations.

Pendant le processus d'assemblage, assurez-vous que l'armoire reste stationnaire et évitez toute opération de mouvement.

Step 22

Étape 22

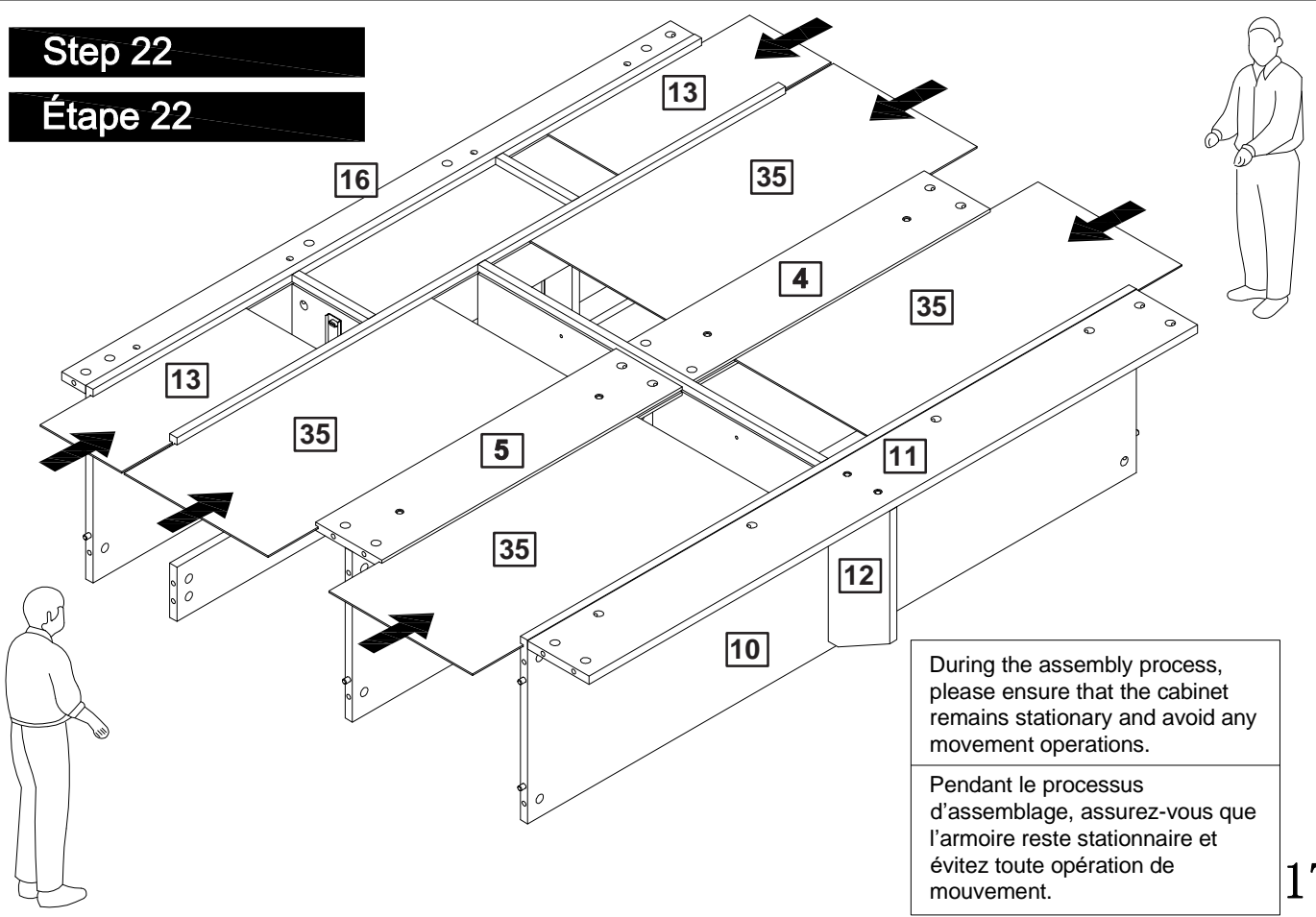

During the assembly process, please ensure that the cabinet remains stationary and avoid any movement operations.

Pendant le processus d'assemblage, assurez-vous que l'armoire reste stationnaire et évitez toute opération de mouvement.

Assembly Instructions / Instructions de montage

Step 23

Étape 23

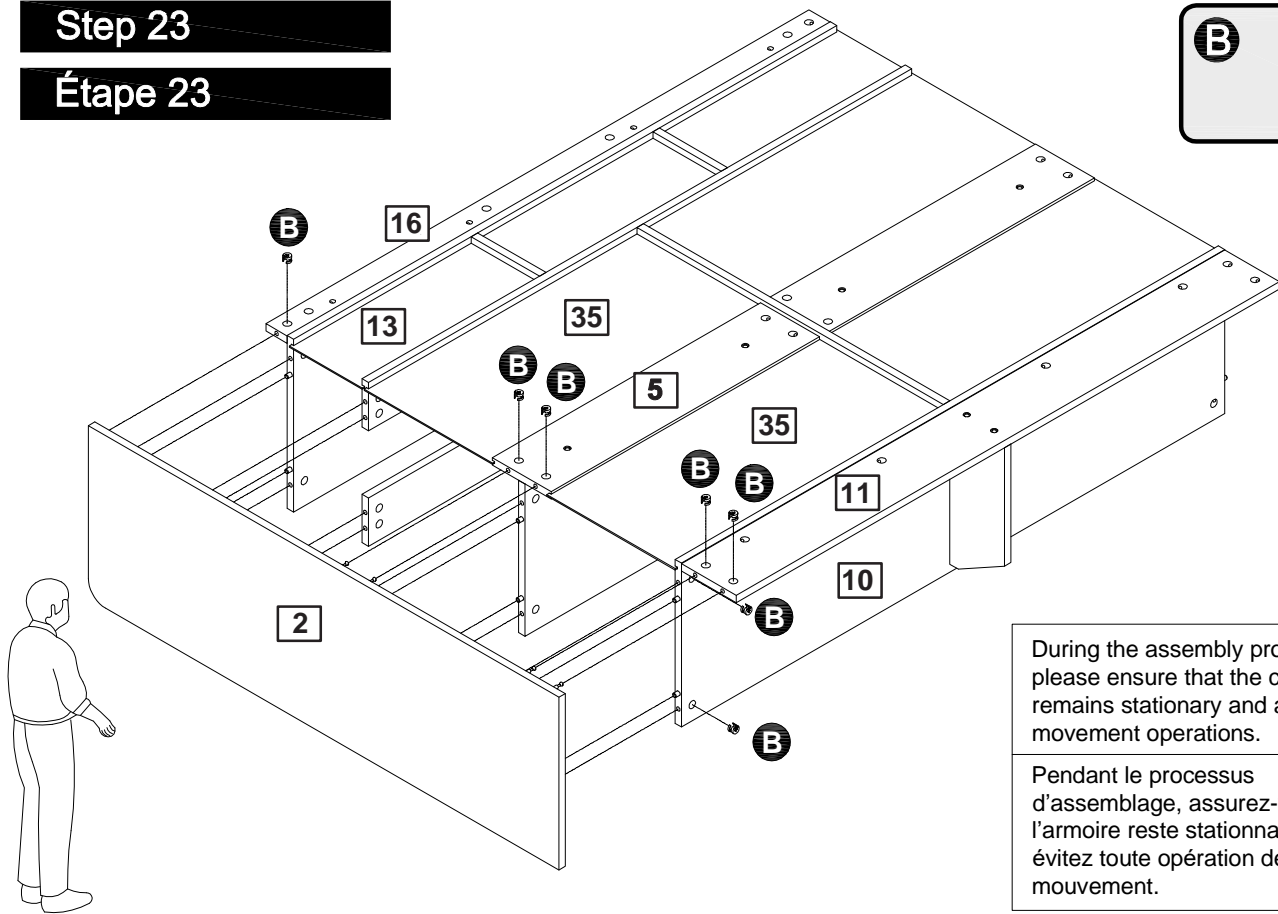

During the assembly process, please ensure that the cabinet remains stationary and avoid any movement operations.

Pendant le processus d'assemblage, assurez-vous que l'armoire reste stationnaire et évitez toute opération de mouvement.

Step 24

Étape 24

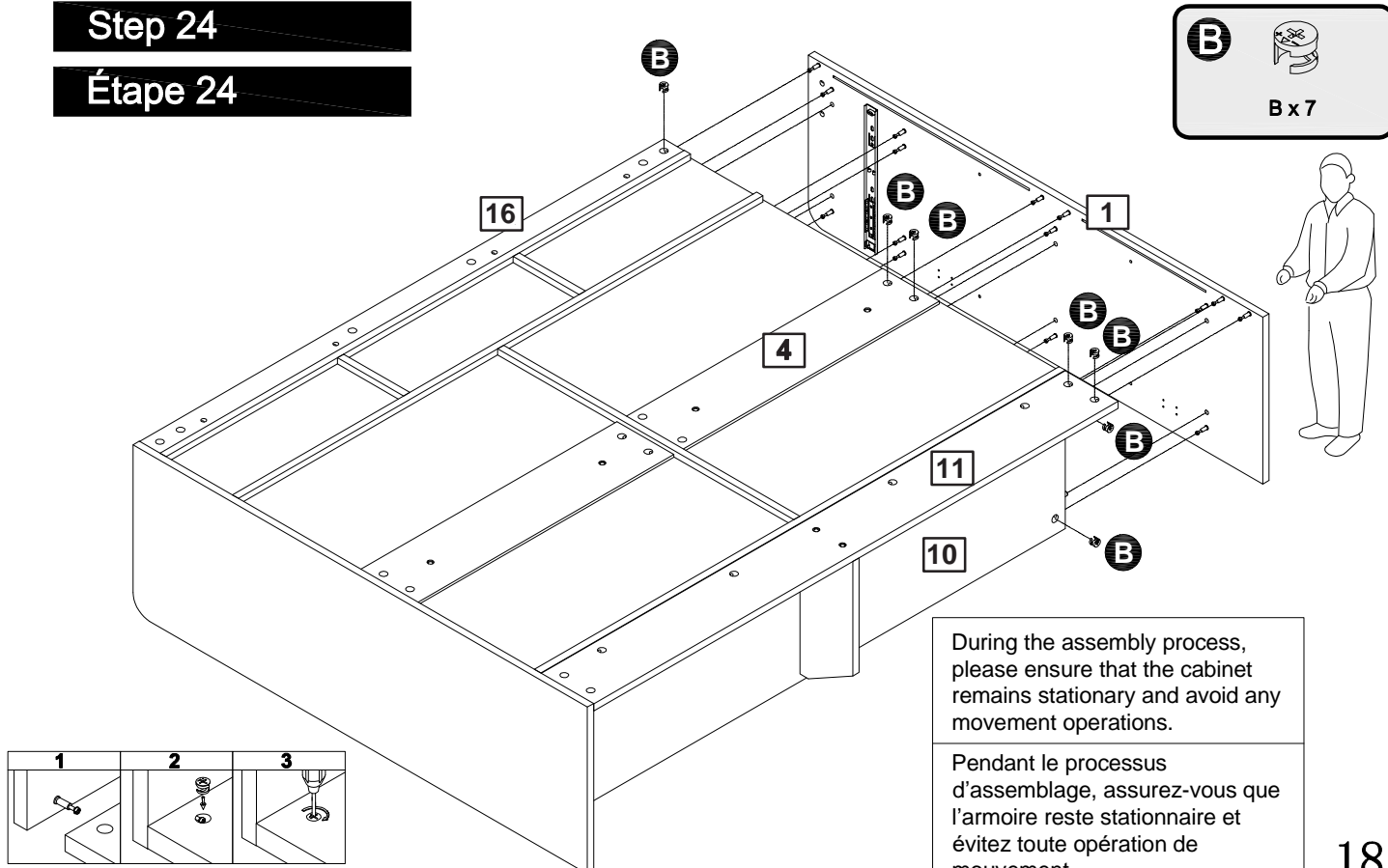

During the assembly process, please ensure that the cabinet remains stationary and avoid any movement operations.

Pendant le processus d'assemblage, assurez-vous que l'armoire reste stationnaire et évitez toute opération de mouvement.

Assembly Instructions / Instructions de montage

Step 25

Étape 25

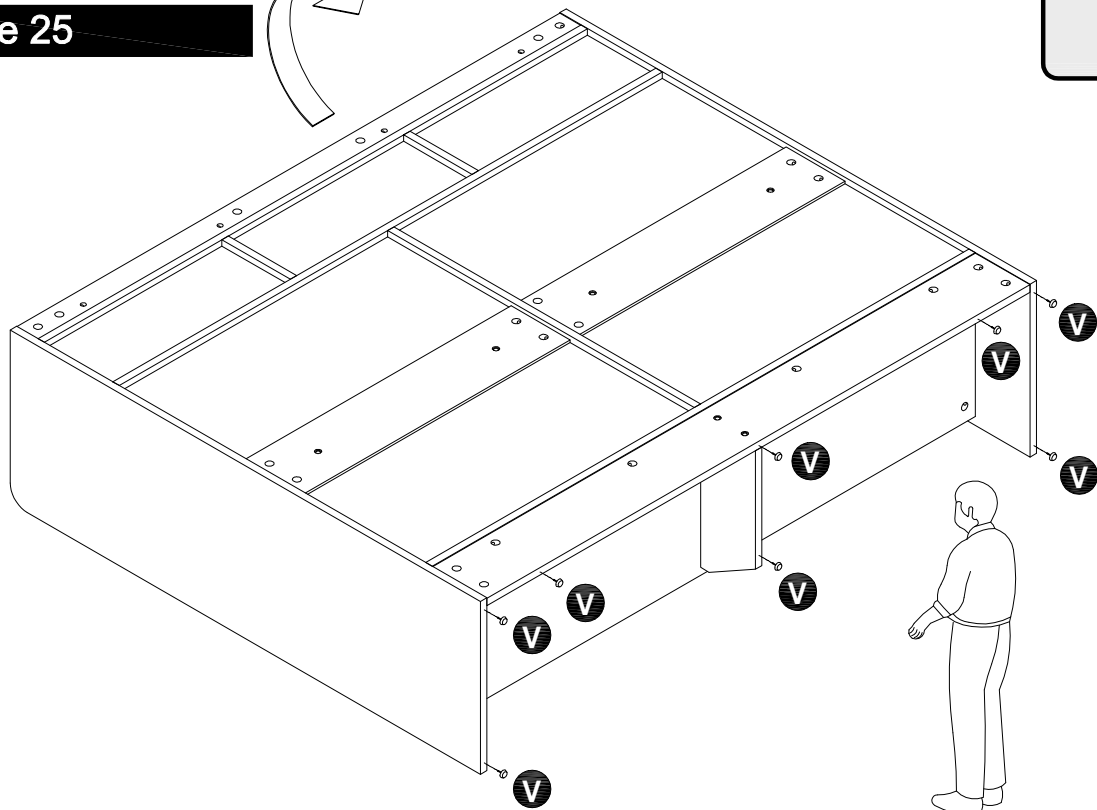

V 
V x 8

Step 26

Étape 26

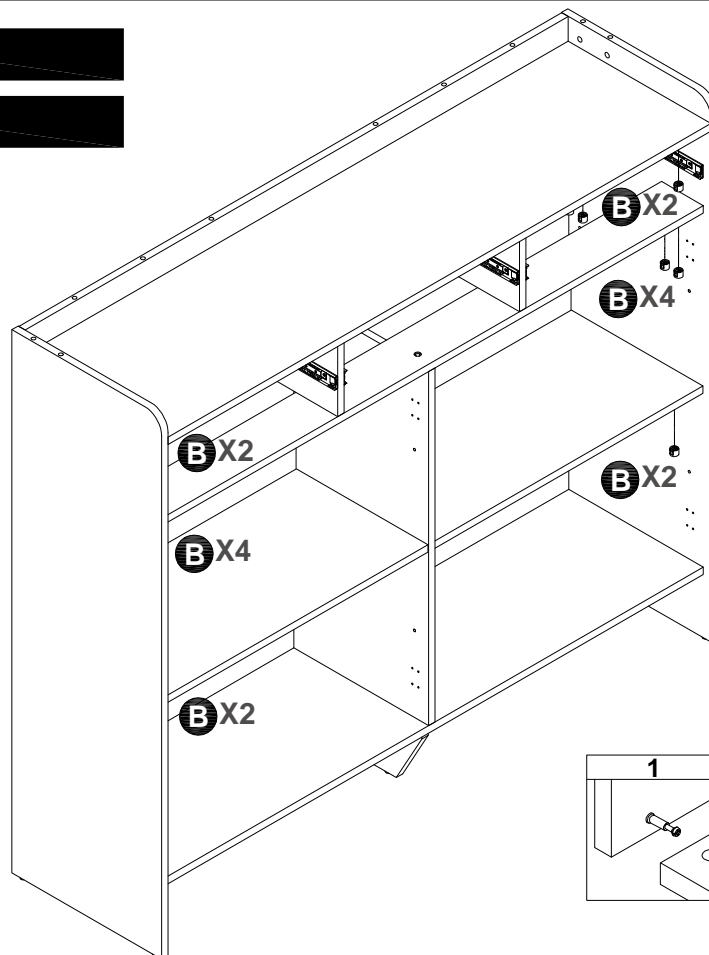

B 
B x 16

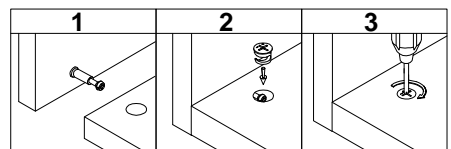

Assembly Instructions / Instructions de montage

Step 27

Étape 27

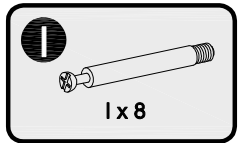
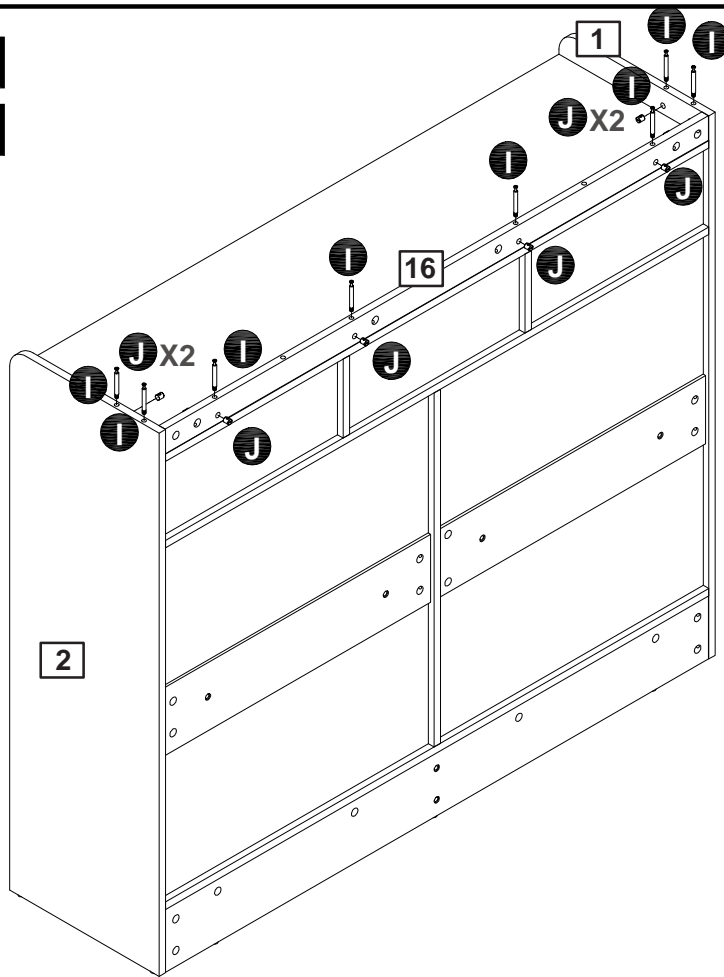
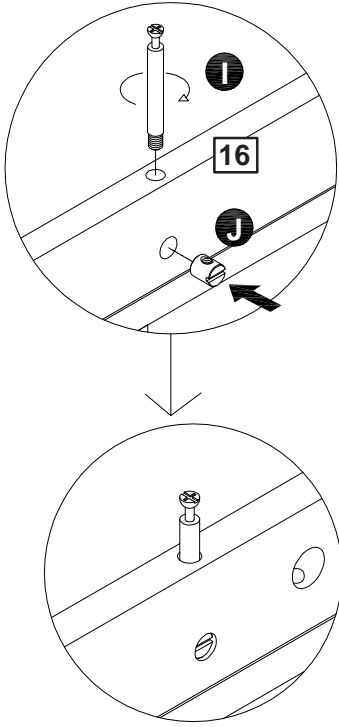

Step 28

Étape 28

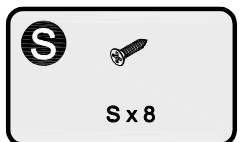
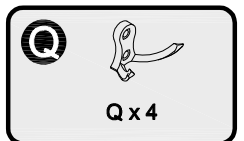
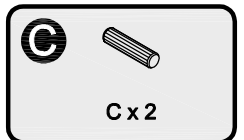
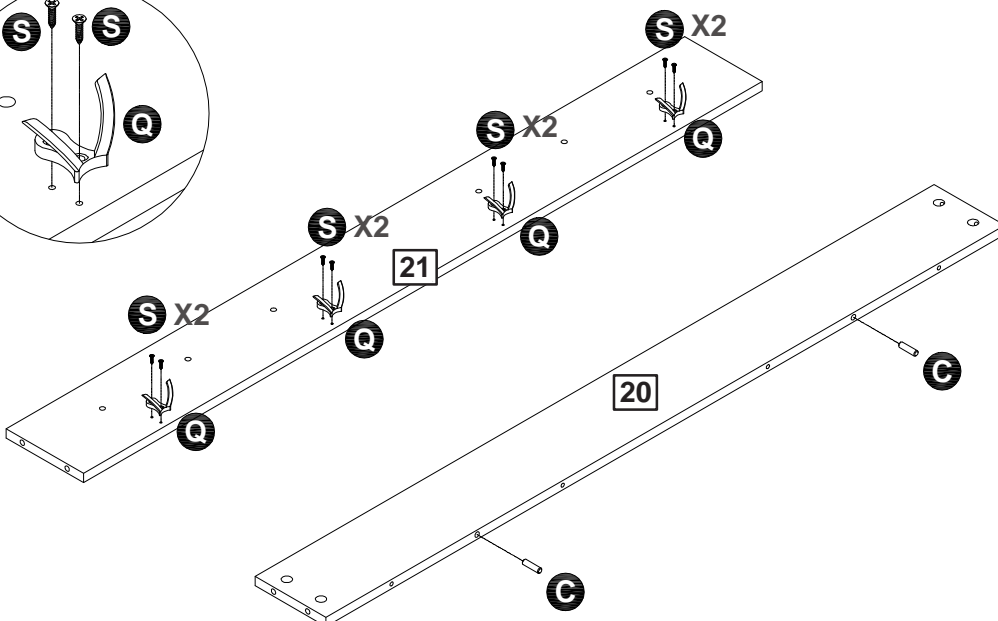
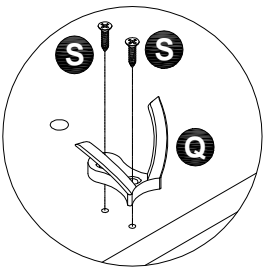

Assembly Instructions / Instructions de montage

Step 29

Étape 29

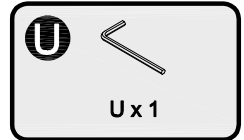
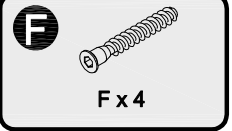
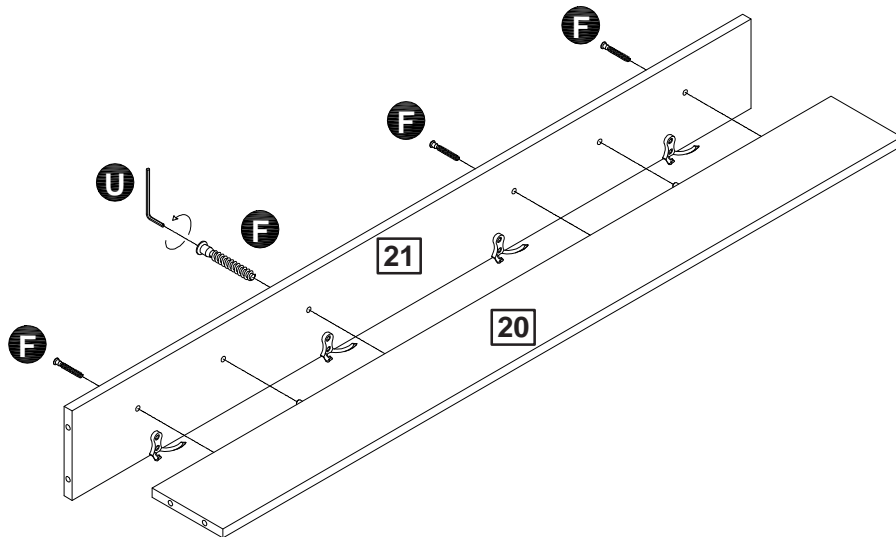

Step 30

Étape 30

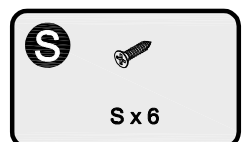
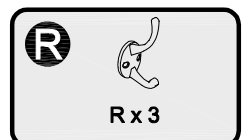
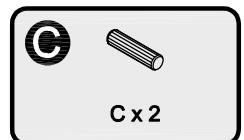
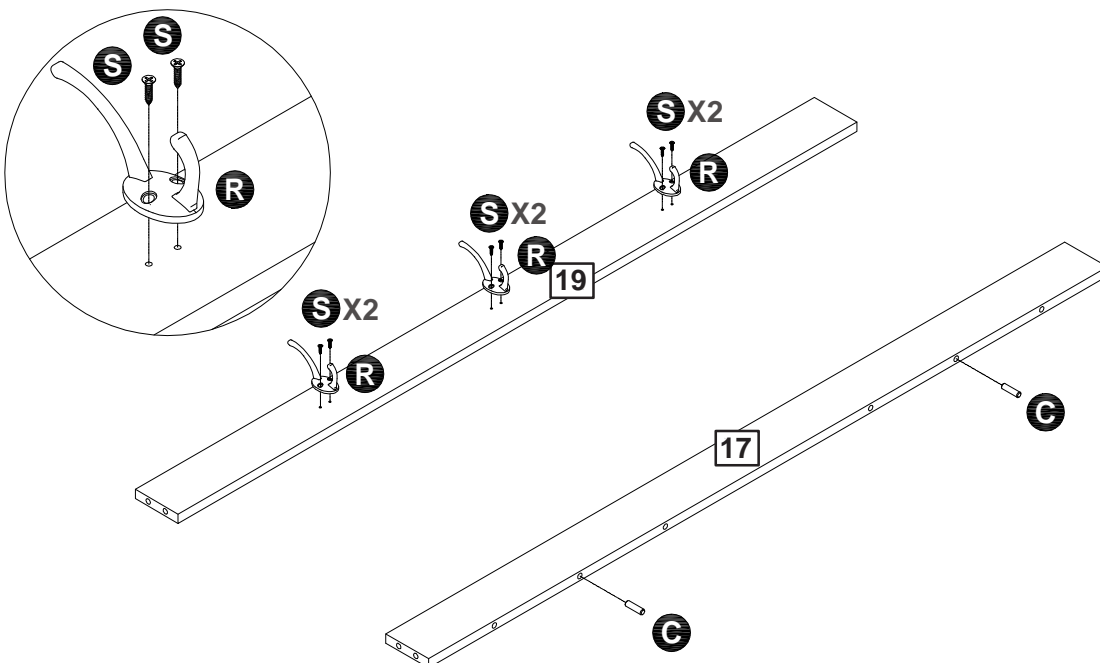

Assembly Instructions / Instructions de montage

Step 31

Étape 31

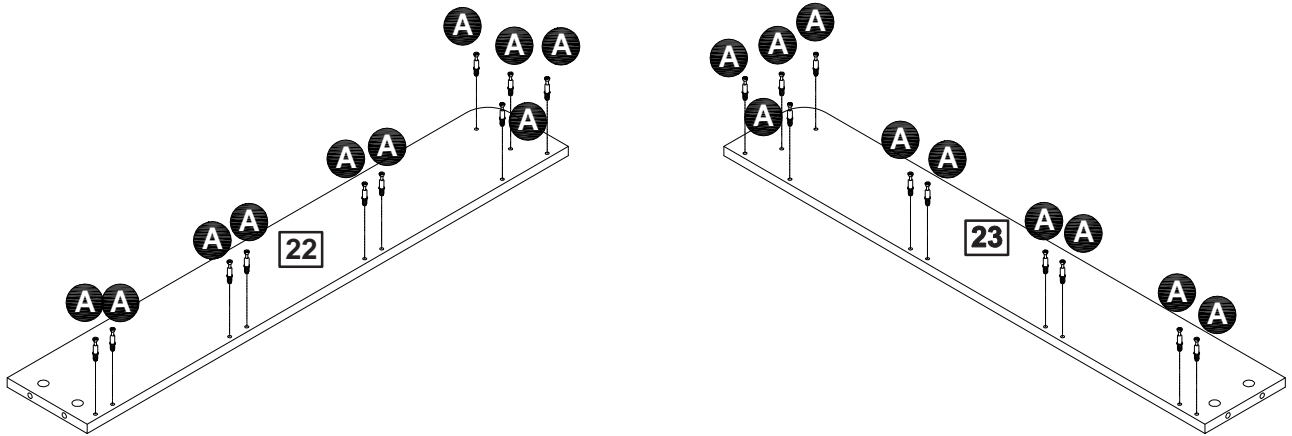
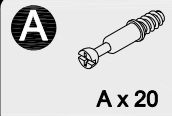

Step 32

Étape 32

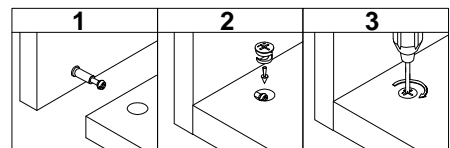
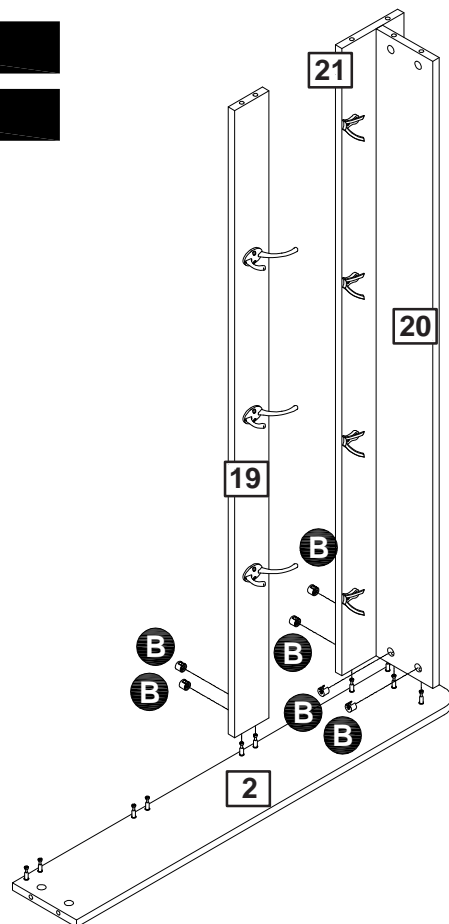

Assembly Instructions / Instructions de montage

Step 33

Étape 33

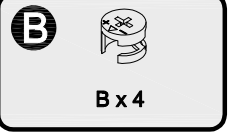
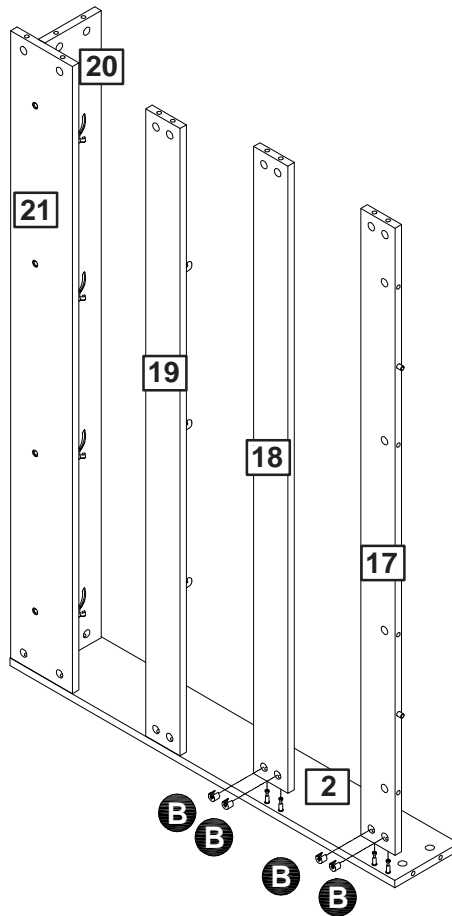
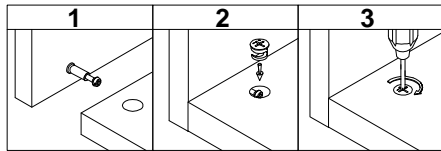

Step 34

Étape 34

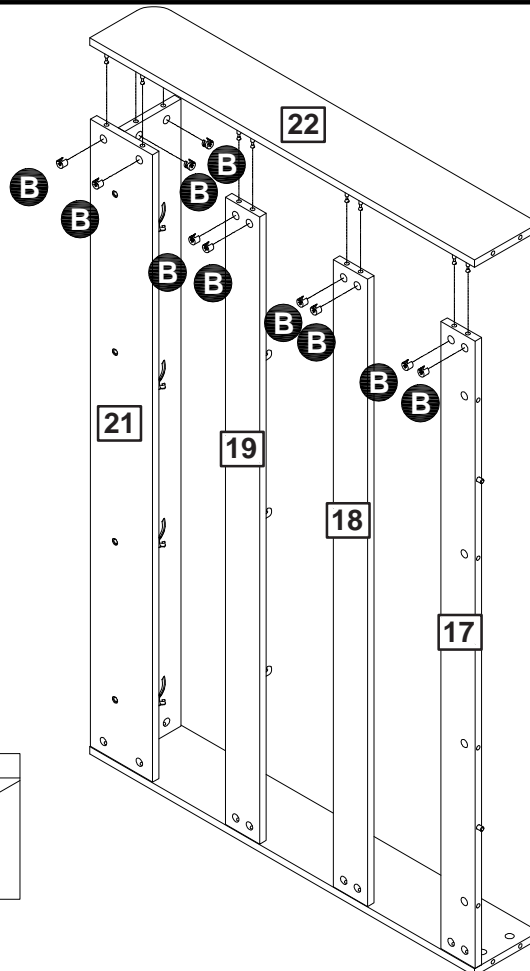
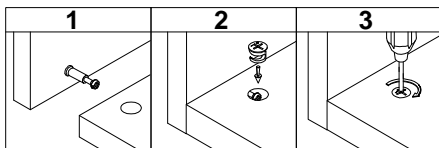

Assembly Instructions / Instructions de montage

Step 35

Étape 35

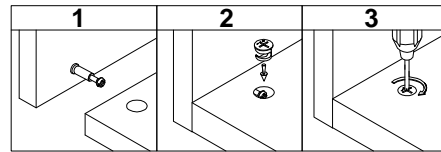
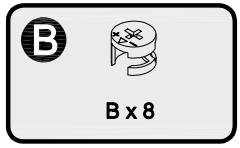
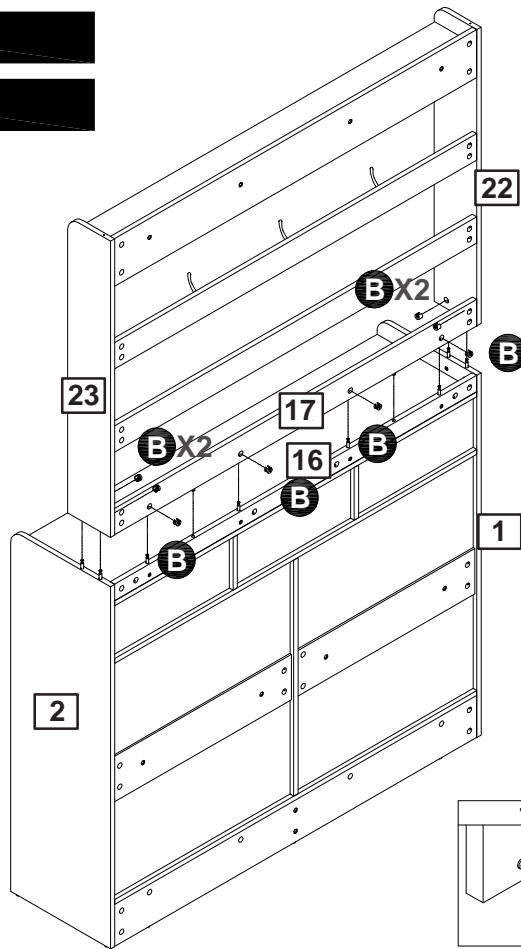

Step 36

Étape 36

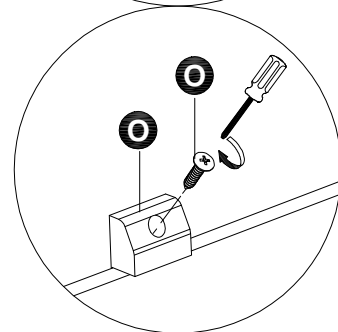
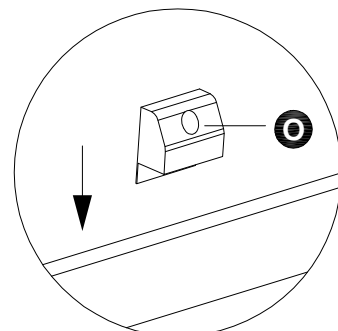
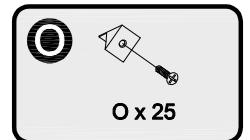
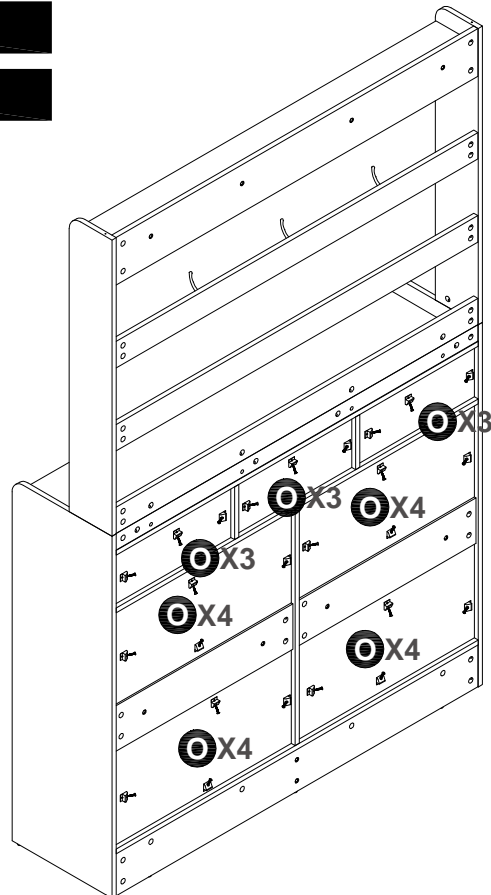

Assembly Instructions / Instructions de montage

Step 37

Étape 37

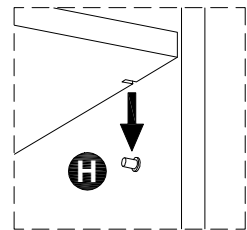
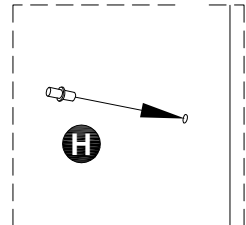
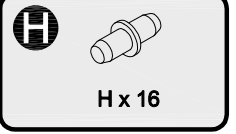
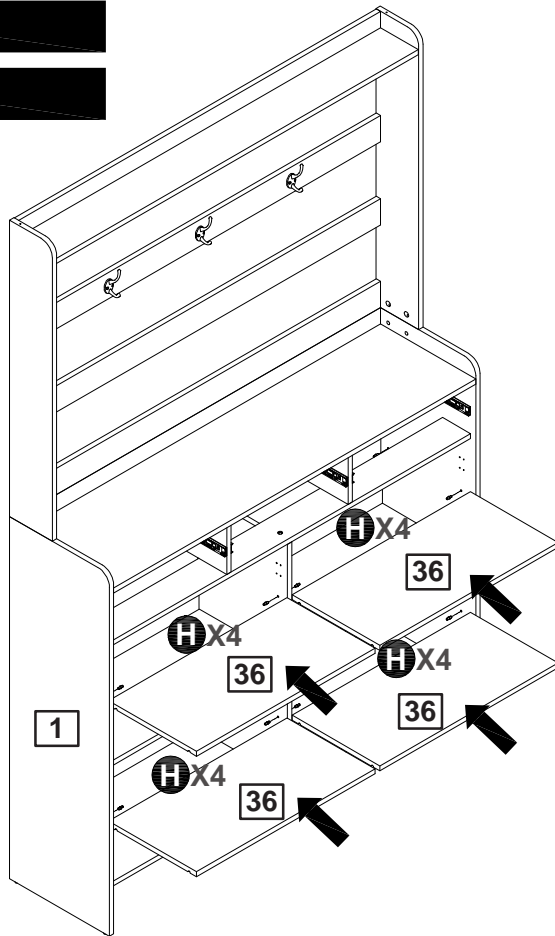

Step 38

Étape 38

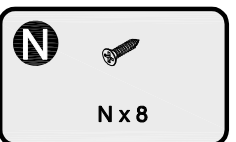
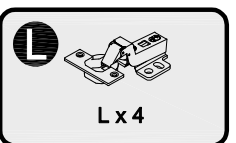
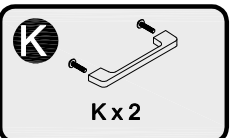
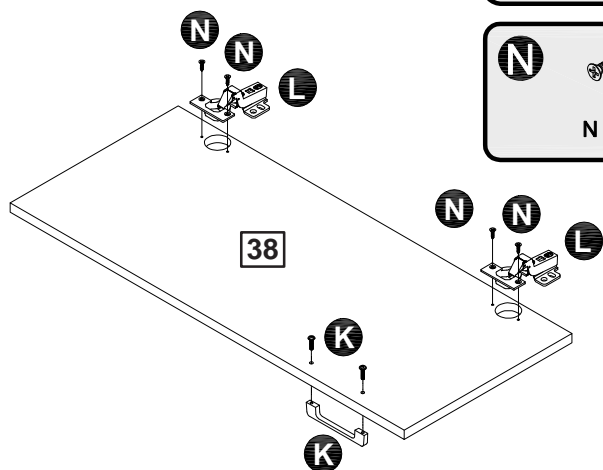
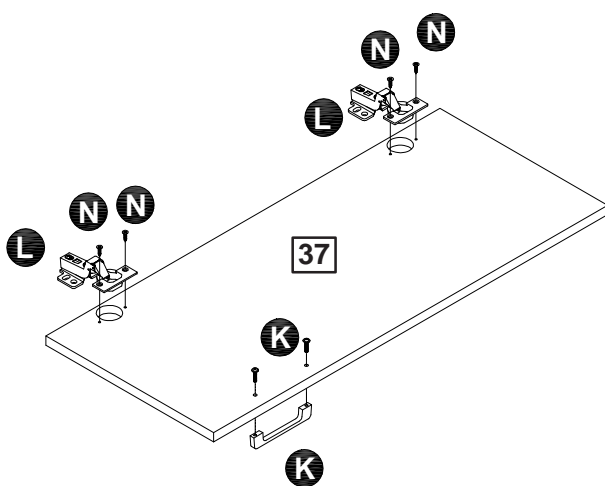

Assembly Instructions / Instructions de montage

Step 39

Étape 39

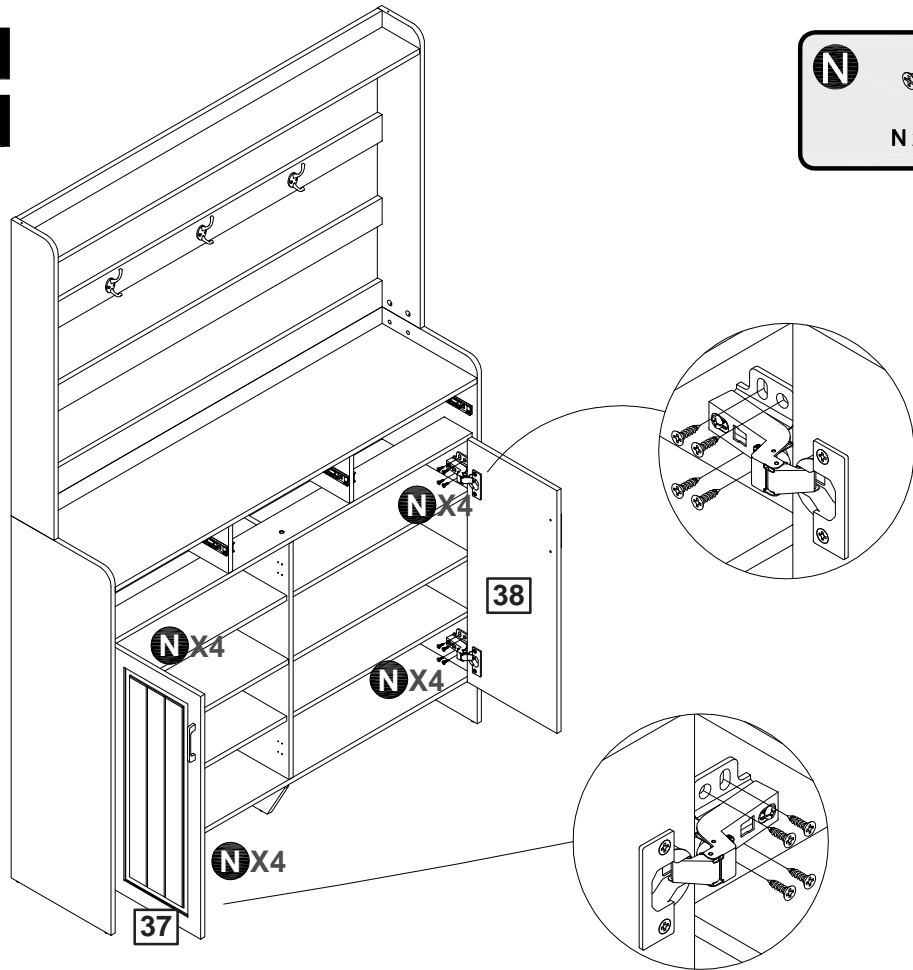

Step 40

Étape 40

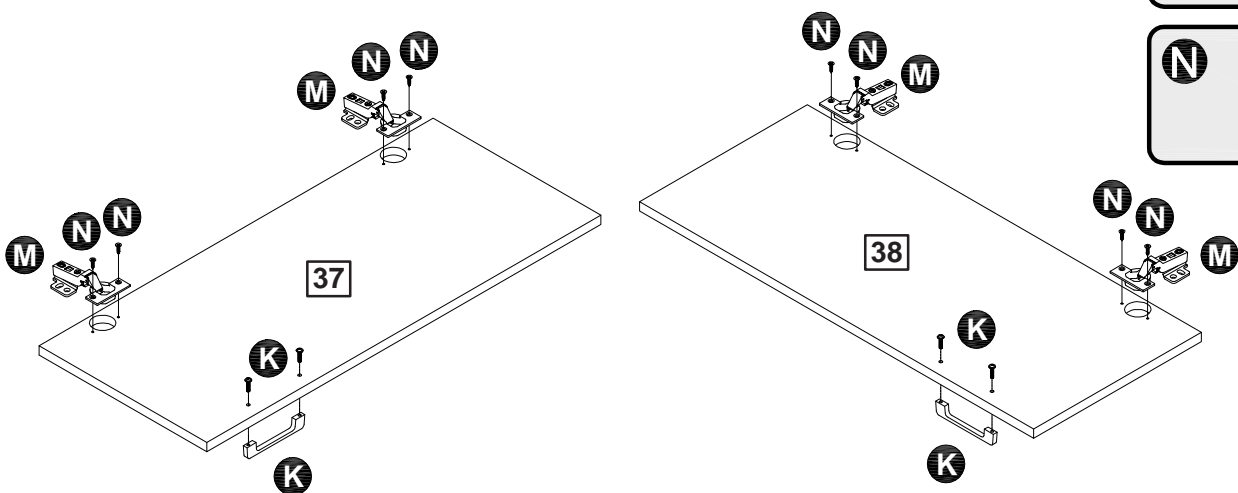

Assembly Instructions / Instructions de montage

Step 41

Étape 41

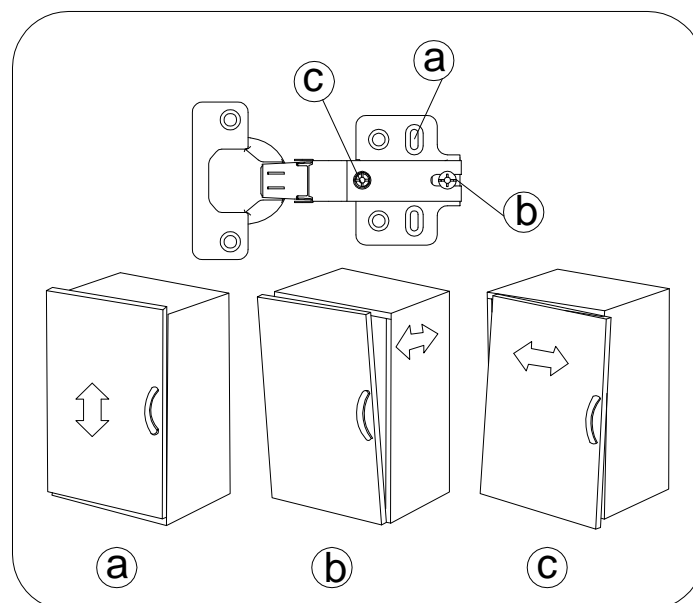
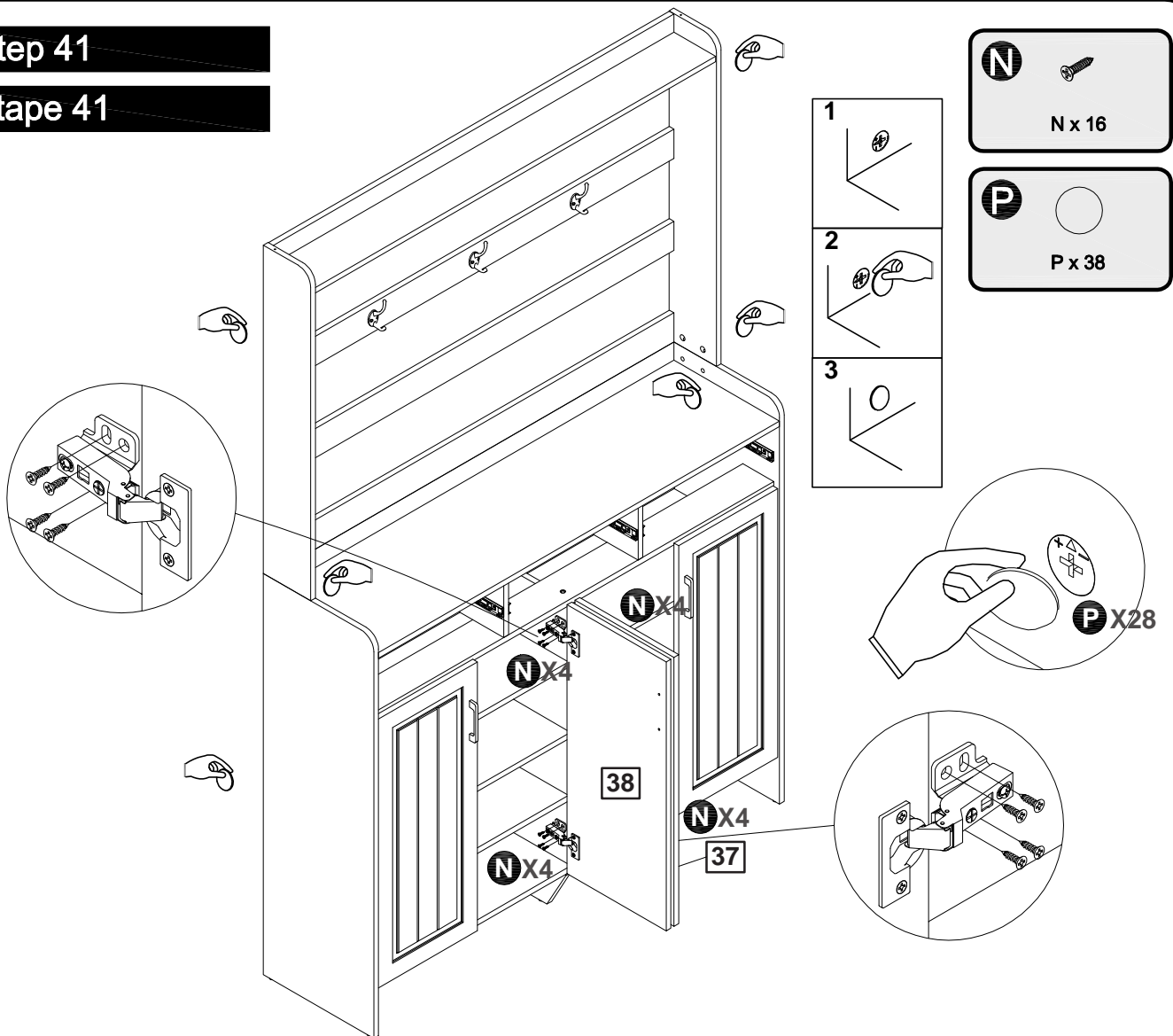

Assembly Instructions / Instructions de montage

Step 42

Étape 42

G



G x 12

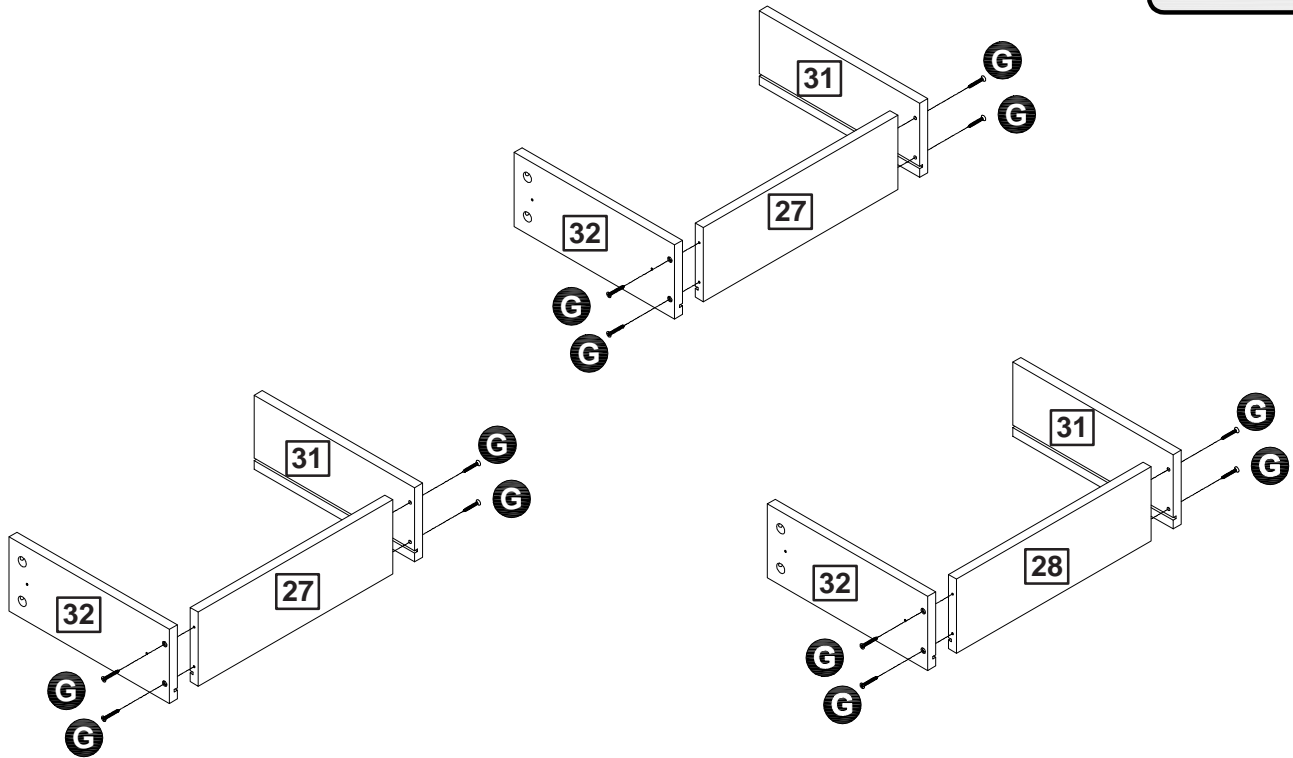

Step 43

Étape 43

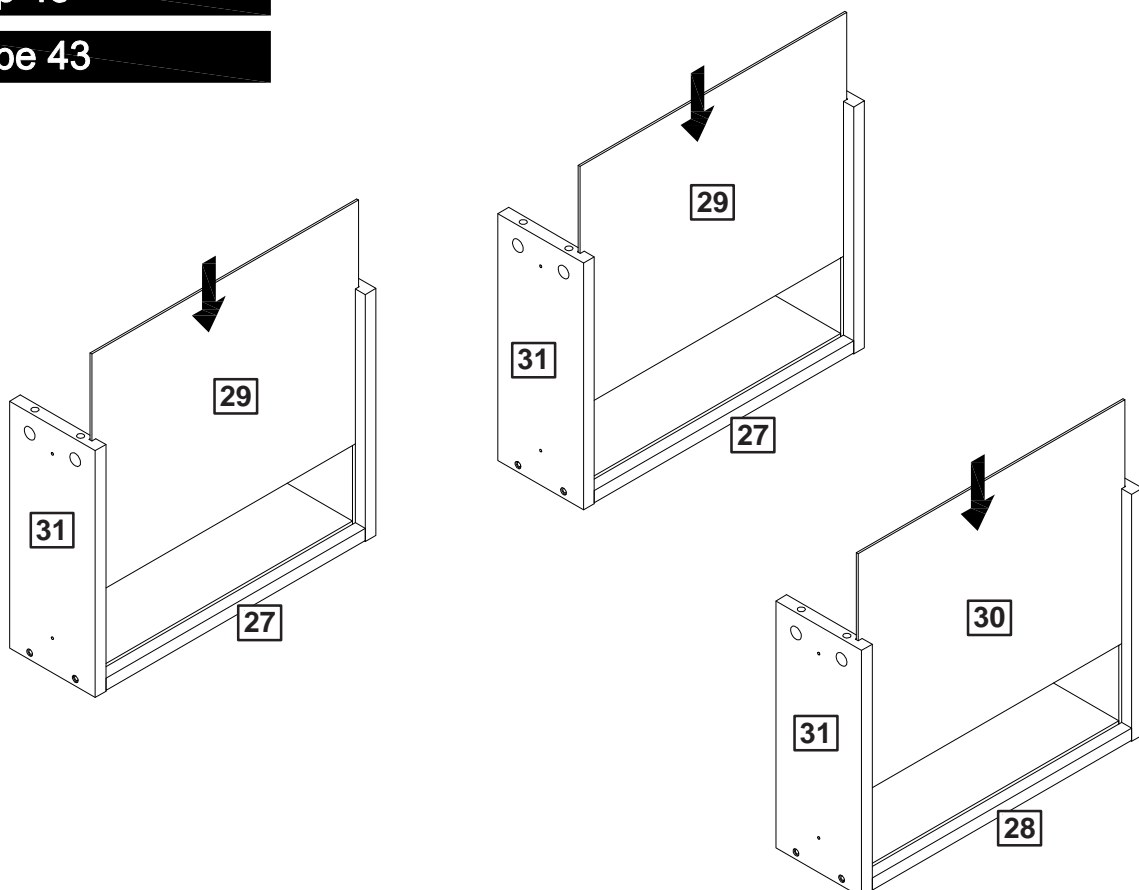

Assembly Instructions / Instructions de montage

Step 44

Étape 44

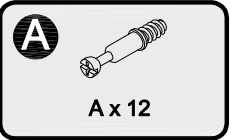
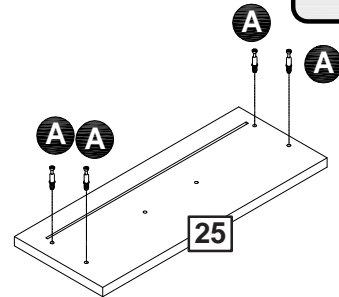
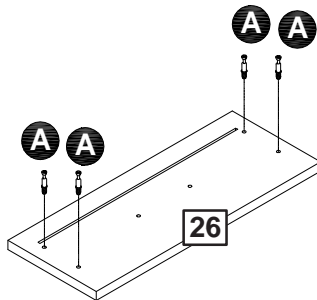
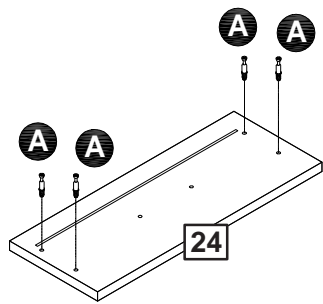

Step 45

Étape 45

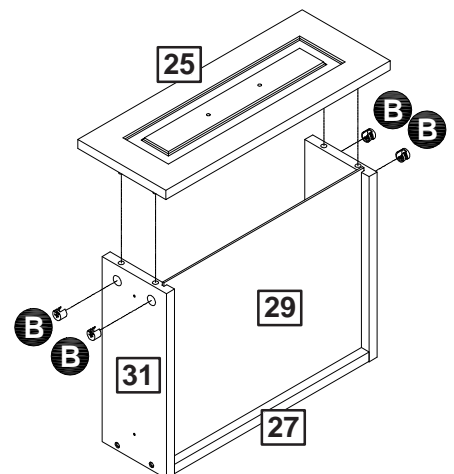
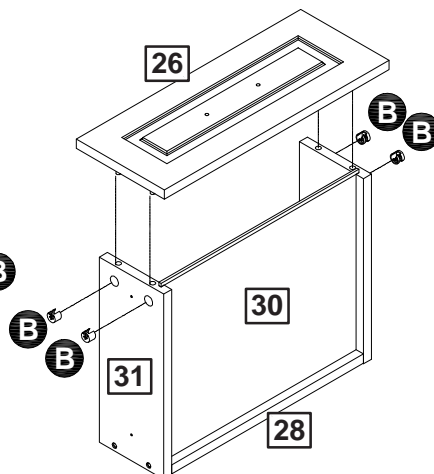
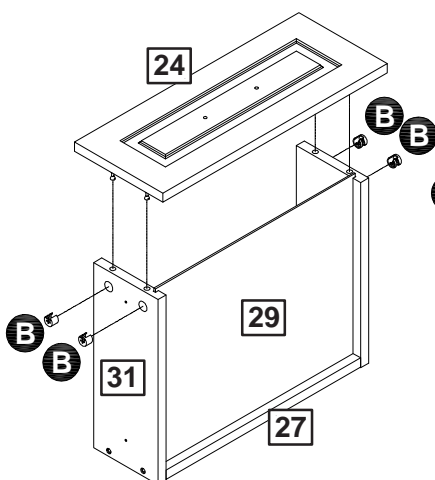
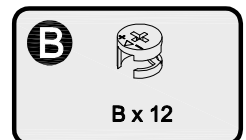
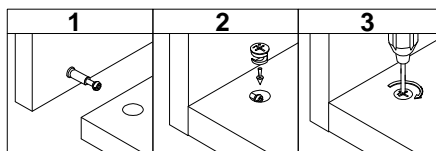

Assembly Instructions / Instructions de montage

Step 46

Étape 46

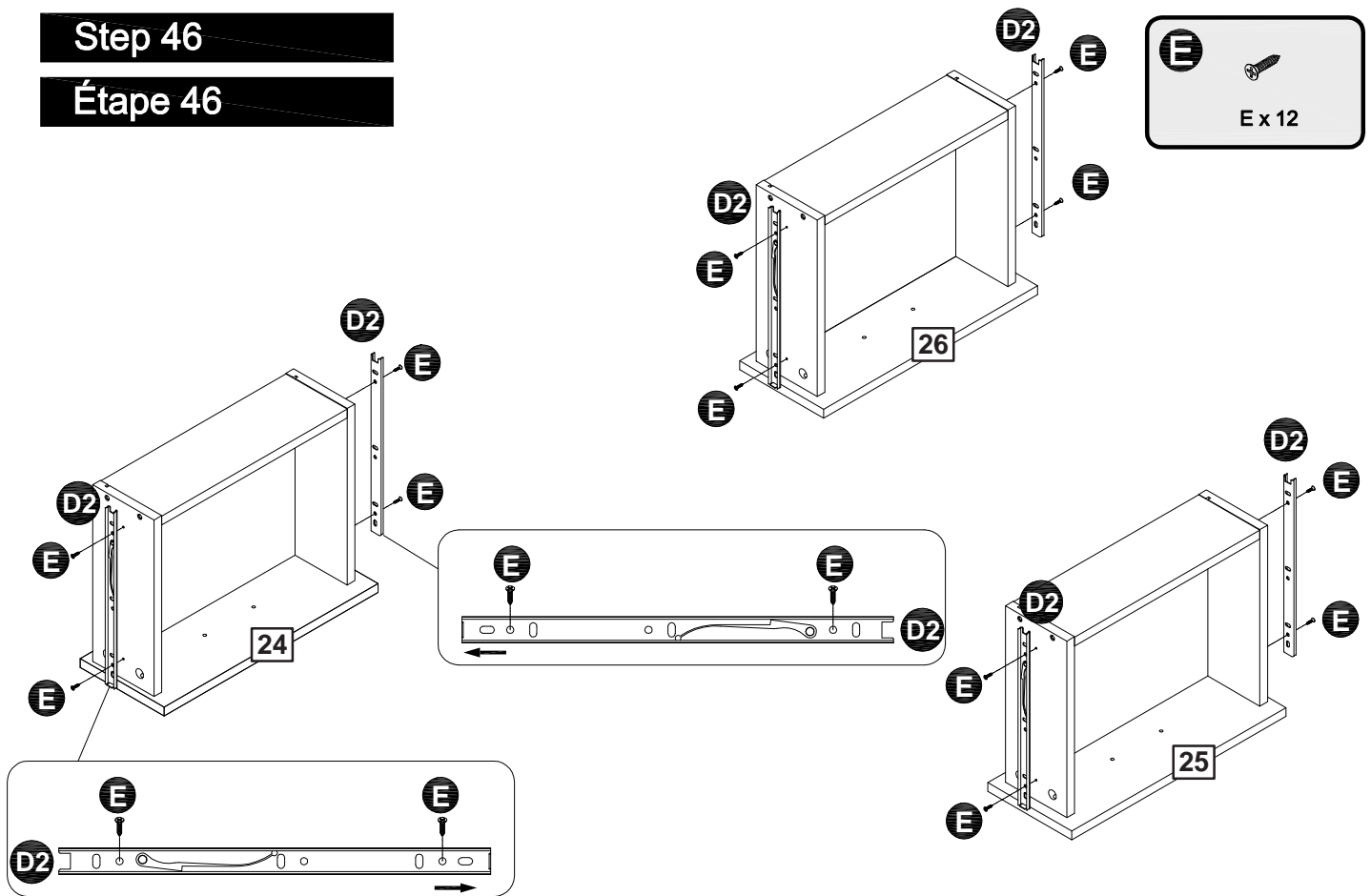

Step 47

Étape 47

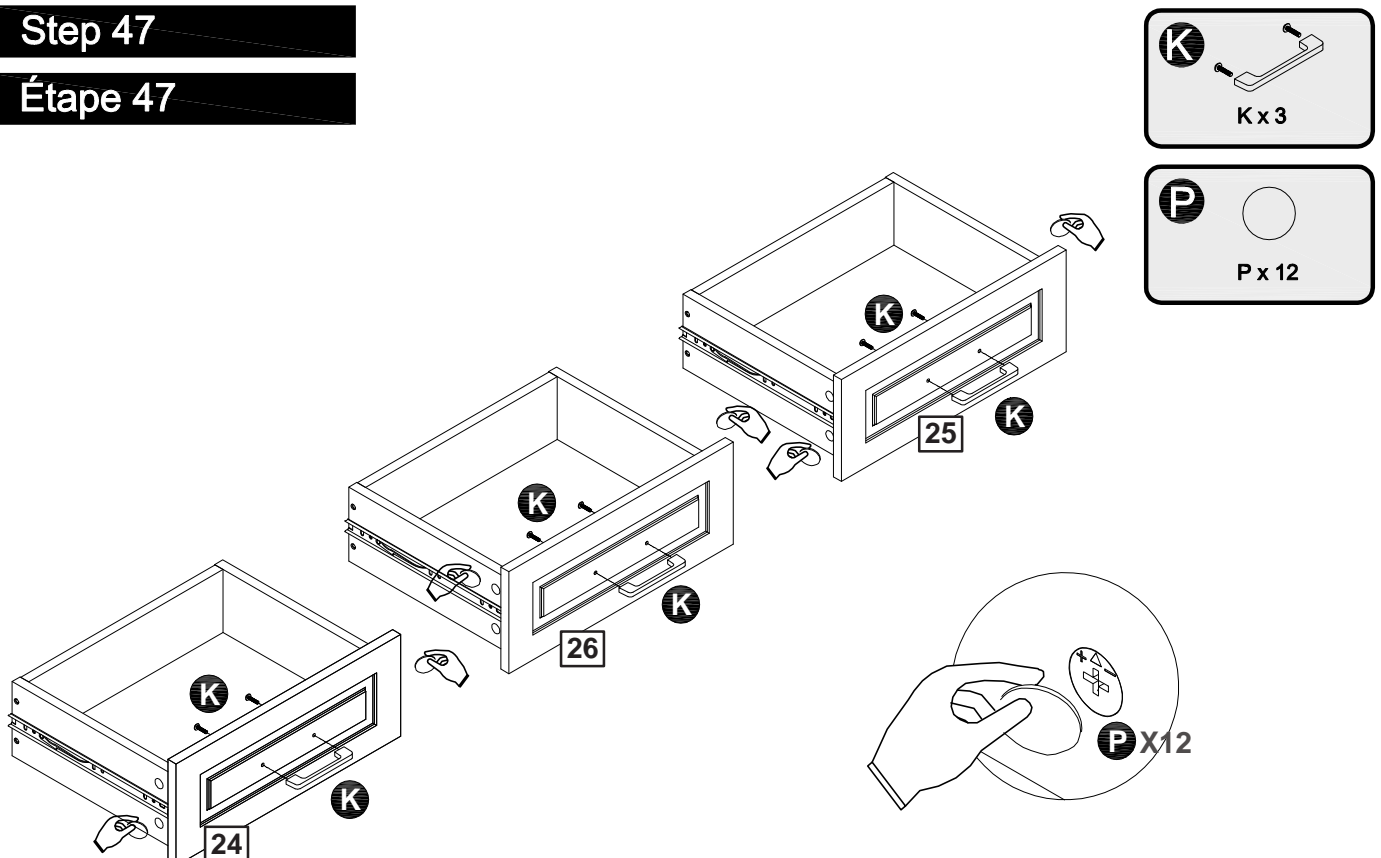

Assembly Instructions / Instructions de montage

Step 48

Étape 48

1. Check Before Installing: Ensure the rails are secure and ball bearings are in place.
1. Vérifier avant l'installation: s'assurer que les rails sont sécurisés et que les roulements à billes sont en place.
2. Prepare: Slide the ball bearings to the front of the rails before closing.
2. Préparer: faites glisser les roulements à billes à l'avant des rails avant de les fermer.

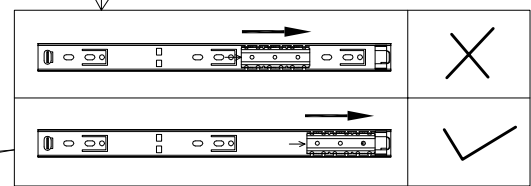
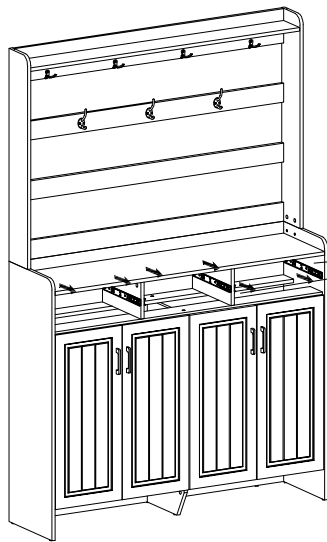

3. Align & Insert: Line up the drawer rails with the main slides and insert both sides at once.
3. Aligner et insérer: aligner les rails du tiroir avec les glissières principales et insérer les deux côtés à la fois.

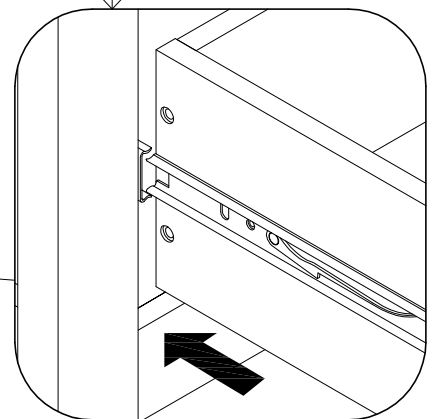
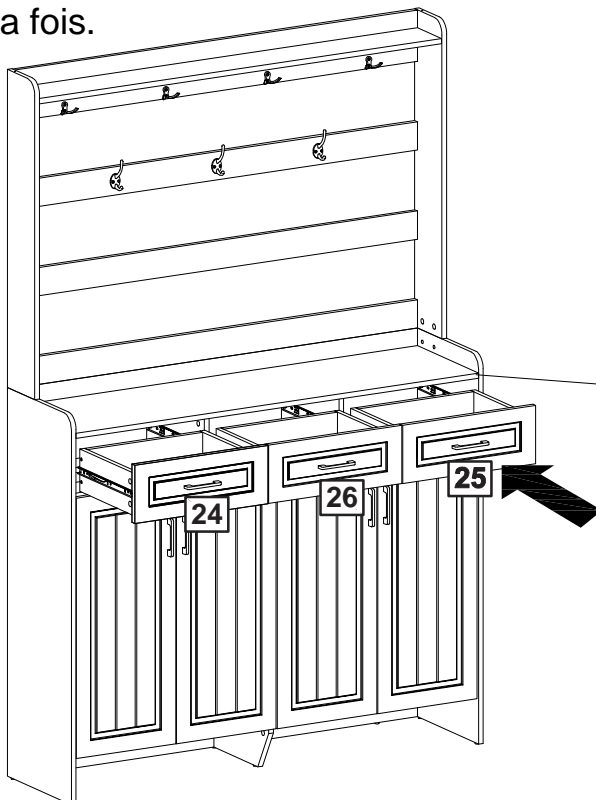

4. Fit: Open and close the drawer slowly three times to align and seat the ball bearings.
4. Ajustement: ouvrir et fermer le tiroir lentement trois fois pour aligner et asseoir les 31 roulements à billes.

Assembly Instructions / Instructions de montage

Step 49

Étape 49

5. To Remove the Drawer:

Fully extend the drawer.

Push the left release latch up and the right one down.

Pull the drawer out while supporting it.

5. Pour retirer le tiroir:

Étendre complètement le tiroir.

Poussez le verrou gauche vers le haut et le verrou droit vers le bas.

Retirez le tiroir tout en le soutenant.

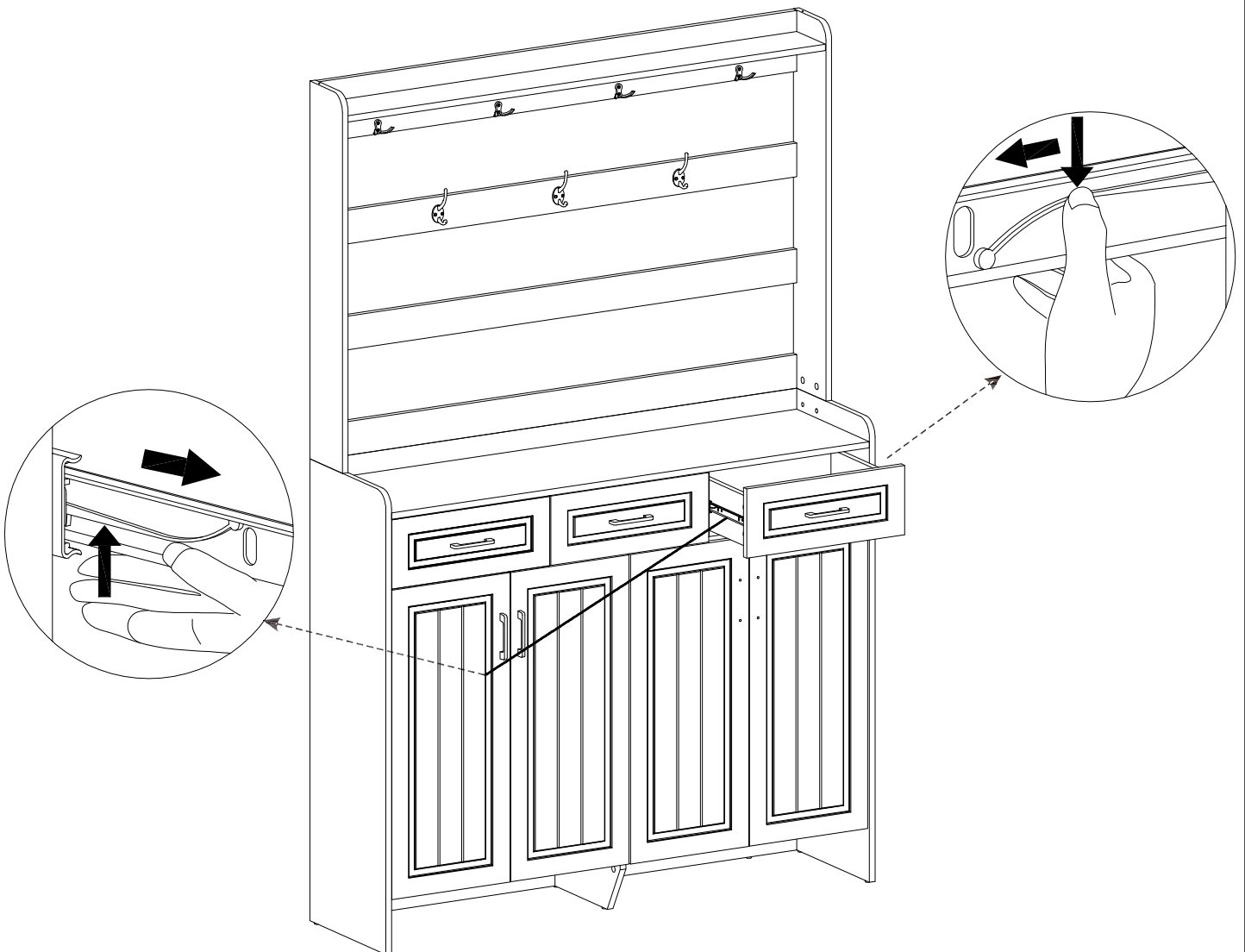

★ If the drawer does not go in smoothly please take it out and repeat the steps.

★ Si le tiroir n'entre pas en douceur, retirez-le et répétez Les étapes.

Assembly Instructions / Instructions de montage

Step 50

Étape 50



DANGER - To prevent furniture from toppling attach, mount, bolt or otherwise secure to walls and floors.
Do not put heavy items on top shelves.
Do not place unstable furniture near where children play.
An anchor kit suitable for plaster walls is included with this item, if you require a different kit consult your nearest hardware store.

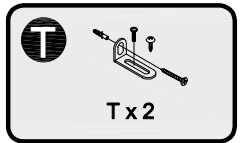

WALL

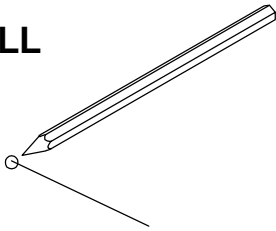

(1)

WALL

drilling hole
Ø6x30mm

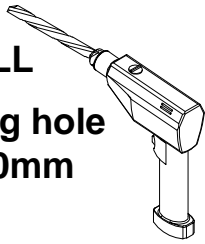

(2)

WALL

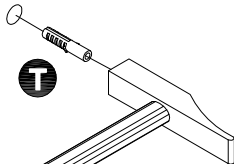

(3)

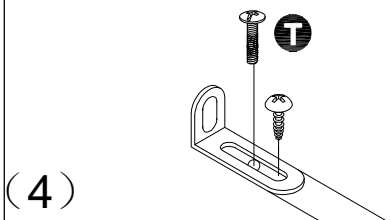

(4)

WALL

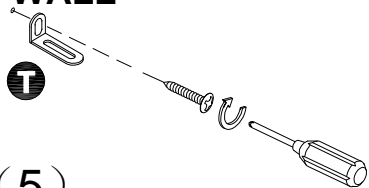

(5)

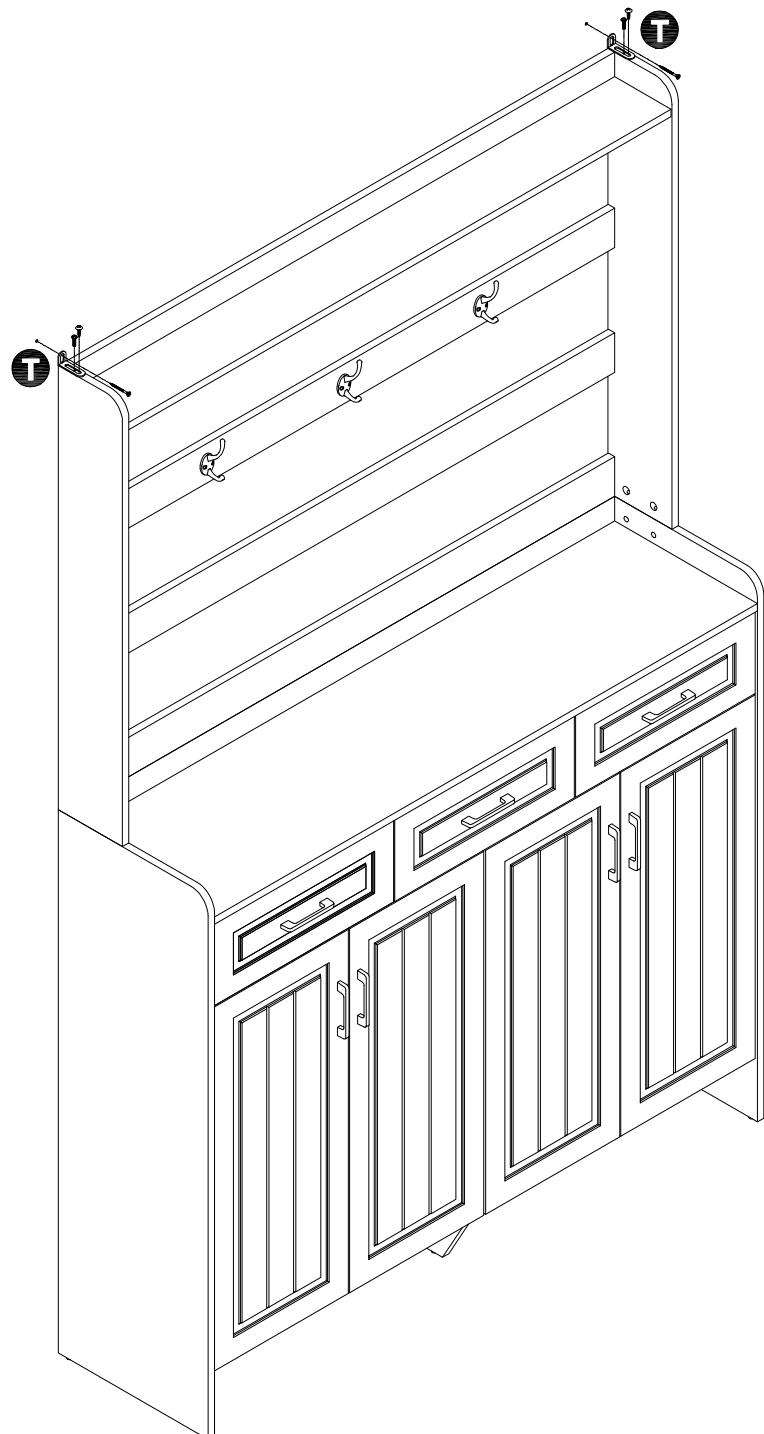

Assembly is complete.
L'assemblage est terminé.

The ways to adjust the door

- Before adjusting the hinge, please check whether the cabinet is skewed.
- If the skew can not be repaired, please remove the anti-tipping device first, then adjust the cabinet to vertical position.
- Please adjust the hinge with the door open.
- Please operate it with more than 2 people, one person holds the door and the other one adjusts the screw.

Components Name

The door side

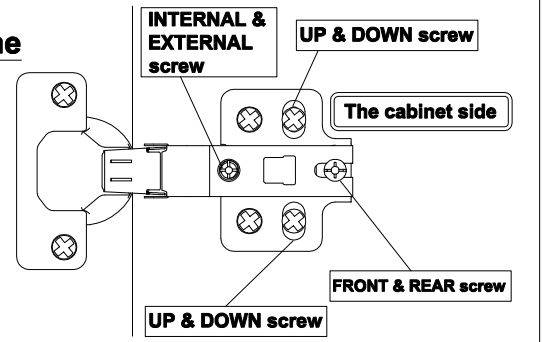

Obvious gaps between doors or Doors don't look closed

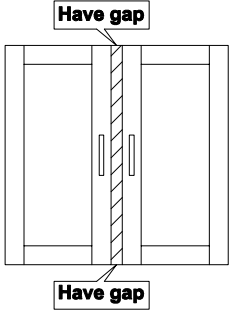

- 1 Turn "internal & external screw" to the right can make the door approach inside. Please adjust the doors little by little..

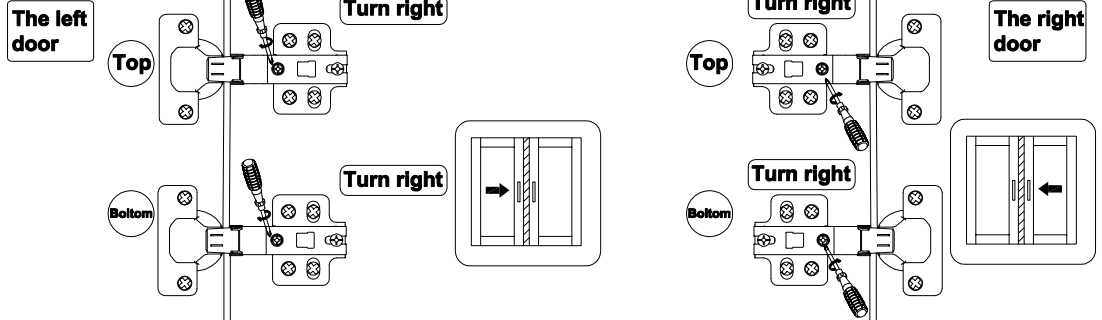

※ If the 2 doors are overlap, please turn the "internal & external screw" to the left.

When door is crooked

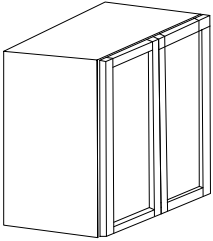

Please take the following steps to adjust first.

- 1 Rotate the "front and rear screws" to the left

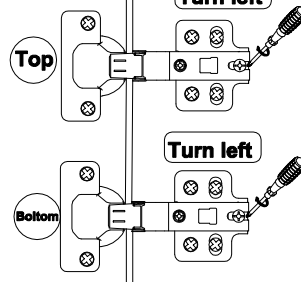

- 2 Push the door to the cabinet

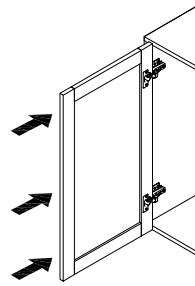

- 3 Rotate the "front and rear screws" to the right

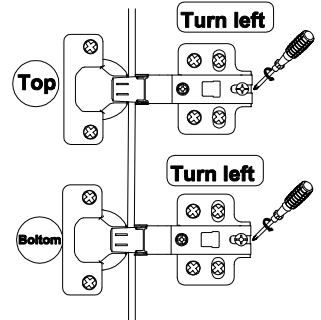

※ After adjusting the "front and rear screw", the door still does not change, please turn the "internal & external screw" to the right slightly.

When door is leaning

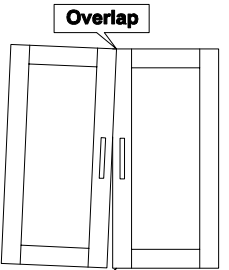

- 1 Turn "internal & external screw" to the left can make the top of the door tilted outward.

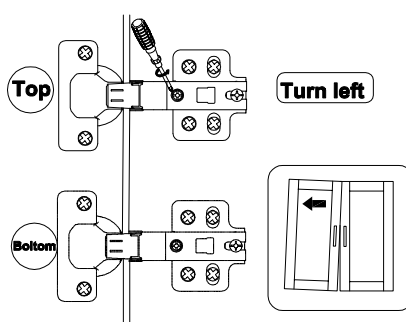

- 1 Turn "internal & external screw" to the left can make the top of the door tilted outward.

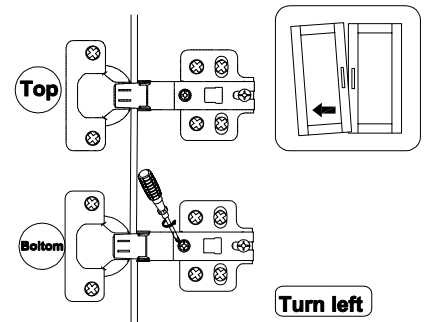

When door is higher on top

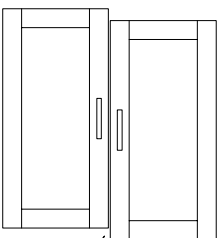

- 1 Turn "up & down screw" to the left

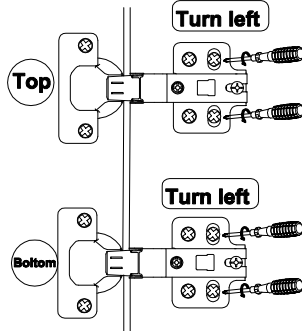

- 2 Lower the door's height so that 2 doors are of the same height.

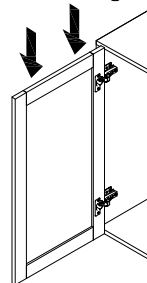

- 3 Turn "up & down screw" to the right

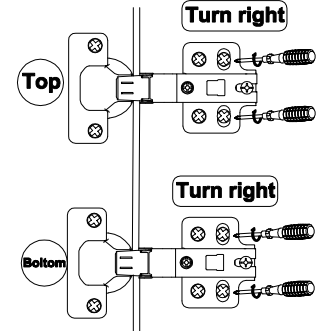

※ if the door is lower on bottom, please lift up the left door slightly on step 2