

ACACIA CALLISTO WITH HEADBOARD

Queen / King



Thank you for purchasing this quality product. Be sure to check all packing material carefully for small parts which may have come loose inside the carton during shipment. Identify and count all parts and compare with the parts list below.

IMPORTANT INFORMATION

Under normal use, ACACIA bed frame will last for years. It is, however, important to follow basic care tips to prolong the life of your bed frame.

USE & CARE

Your bed frame does not require special waxing or oiling. You may dust at any time with a clean, dry, soft cloth. If deeper cleaning is necessary, use a damp, non-abrasive cloth and a solution of cool water and mild detergent, immediately wipe dry.

Moisture and heat can damage a wood finish. To prevent moisture damage, promptly wipe up any spills or any other moisture. To prevent heat damage, avoid placing your bed frame too close to heat sources such as HVAC vents and radiators.

Avoid dragging sharp or rough objects across the surface of your wood bed frame, or it will become scratched.

Wood may expand and contract with seasonal humidity changes. Maintaining consistent humidity levels will minimize movement in the wood and help to prevent warping.

Over time, air and sunlight may change the color of natural wood. To prevent fading, avoid placing your bed frame in direct sunlight.

Upon completion of assembly be sure all screws, bolts and fastening devices have been securely tightened. A frequent check should be made.

Ensure that your headboard is securely attached regularly.

Any modification or failure to follow the recommended care will void the product warranty.

WARRANTY INFORMATION

Thank you for choosing ACACIA. We stand behind our brand and the quality of the items we sell.

The Bed Frame comes with a 5-year limited manufacturing warranty that covers defects in material and workmanship, cracked wood not caused by dry or extreme heat, missing delivery parts or missing hardware, and scratches from shipping. The warranty does not cover normal wear and tear, for products used commercially or for failures caused by accidents, abuse, alteration, modification, misuse or improper care. There are no other express warranties beyond the terms of this limited warranty. In no event shall any implied warranties, including merchantability and fitness for a particular purpose, extend beyond the duration of the express warranty contained herein. In no event shall ACACIA be liable for incidental or consequential damages.

All products are carefully inspected prior to shipment. Please carefully inspect your bed frame at the time of delivery. Replacement parts or products will be sent at our discretion if the defect is the result of any fault on our side. Proof of purchase, with the date of purchase as well as photos of the defective merchandise, must be provided. Photos are used to determine the cause of defects and for future quality control.

If you notice anything out of the ordinary, please contact ACACIA Customer Service directly; or if you have any questions, comments or concerns by emailing us at: customerservice@acaciavn.com, or via our Contact Us page at www.acaciavn.com/contact-us

Read all assembly and care instructions carefully before using this product. Save these instructions for future reference.

- Select a smooth, level surface to place the bed frame parts.
- Assemble components on a soft, clean surface to avoid scratching and/or damaging the finish.
- Ensure all parts are accounted for before disposing of packaging.
- Moderate risk of death or serious injury to children and animals: The plastic packaging of the Bed Frame is a potential suffocation hazard. Leaving children or animals unsupervised with the empty packaging may lead to death through suffocation. Do not leave children or animals unsupervised. Dispose of unnecessary packaging immediately.
- This package contains small parts. Keep away from children prior and during assembly. Adult assembly required. Screws left after assembly should be kept out of reach of children.
- Lift one long side and middle support legs before moving the bed.
- Adjust the center support legs 90 degrees to the ground before use.
- Only place mattress after complete assembly & placement.

ASSEMBLY

Note: The Bed Frame should be assembled by two adults. If you assemble the Bed Frame alone, be careful when lifting heavy parts. Ensure the assembly area is larger than the Bed Frame. Follow the steps carefully to assemble the Bed Frame correctly.

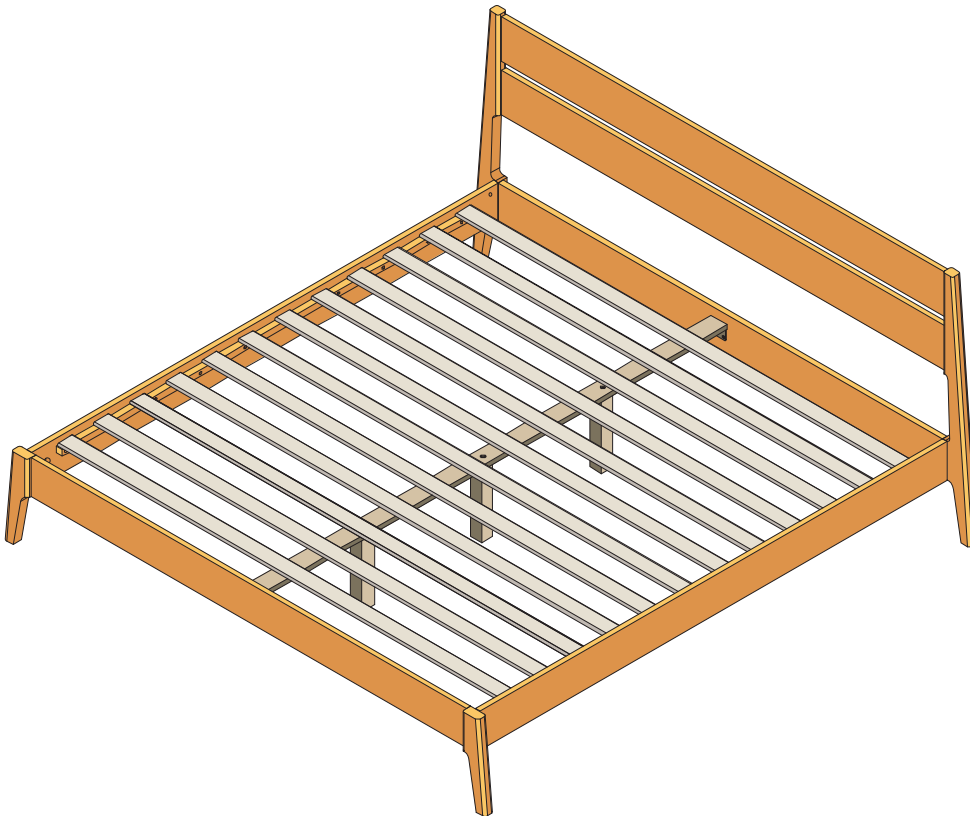

WARNING! Acacia is not responsible for normal wear and tear, for products used commercially or for failures caused by accidents, abuse, alteration, modification, misuse or improper care.

No claims, representations or warranties, whether expressed or implied, are made by our company as to the safety, reliability, durability and performance of any of our company's products. Furthermore, our company accepts no liability whatsoever for the safety, reliability, durability and performance of any of our company's products. In no event shall Tranquillo be liable for incidental or consequential damages.



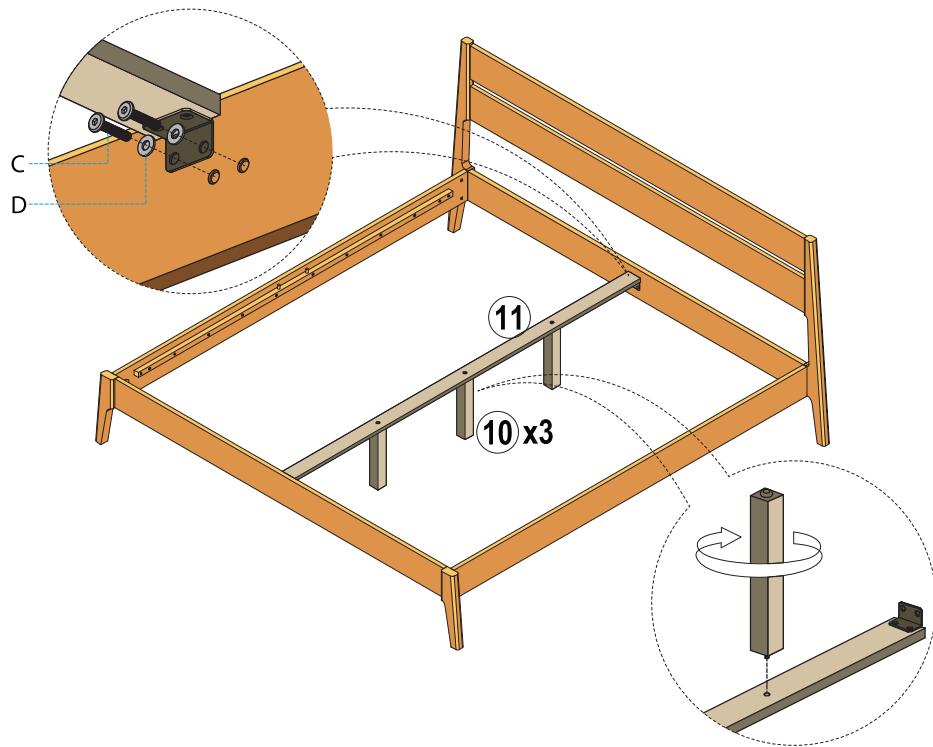

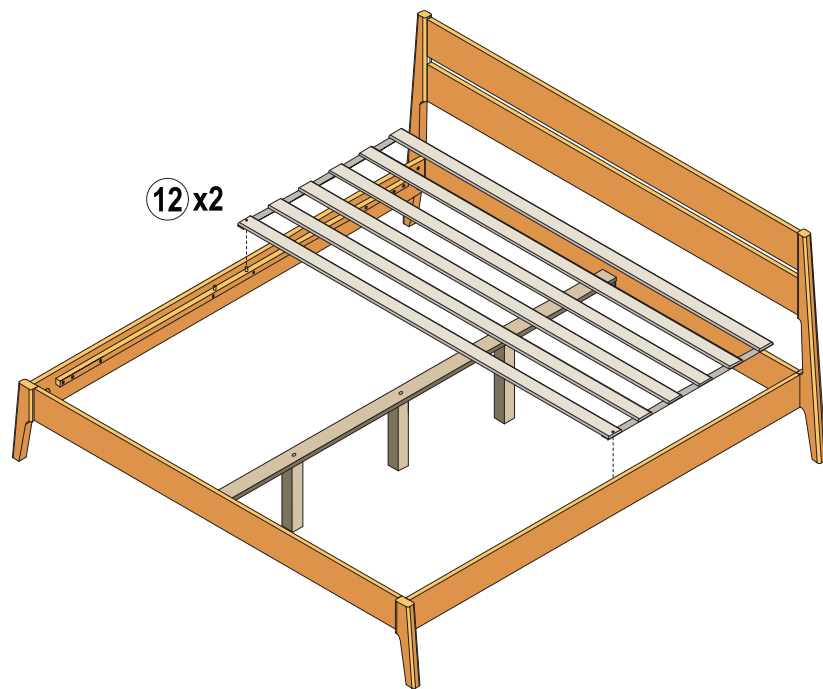

5

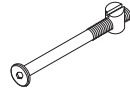

6



HARDWARE LIST

A		Ø6 x 90 BOLT	4
B		Ø8 x 50 BOLT	14
C		Ø8 x 15 BOLT	4
D		Washer	4
E		Washer	14
F		M4	1

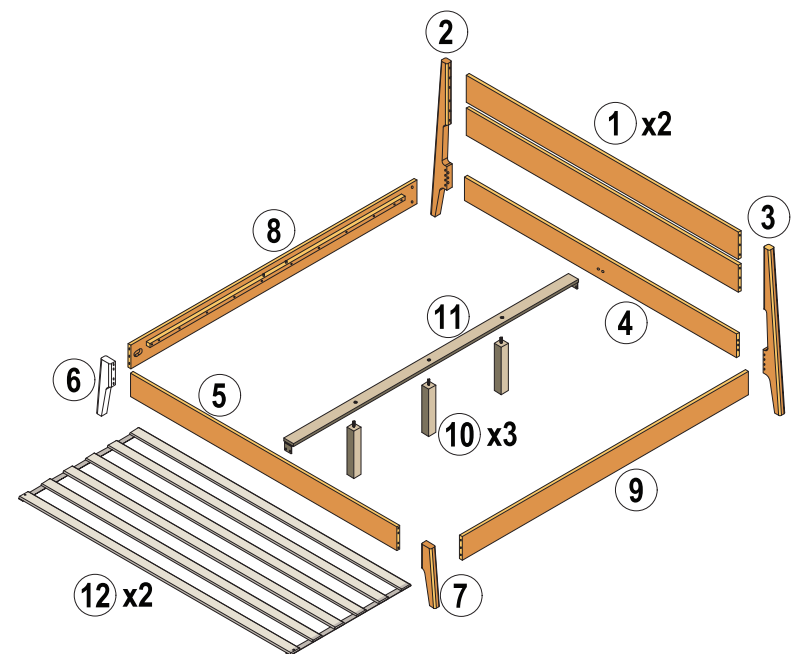

1

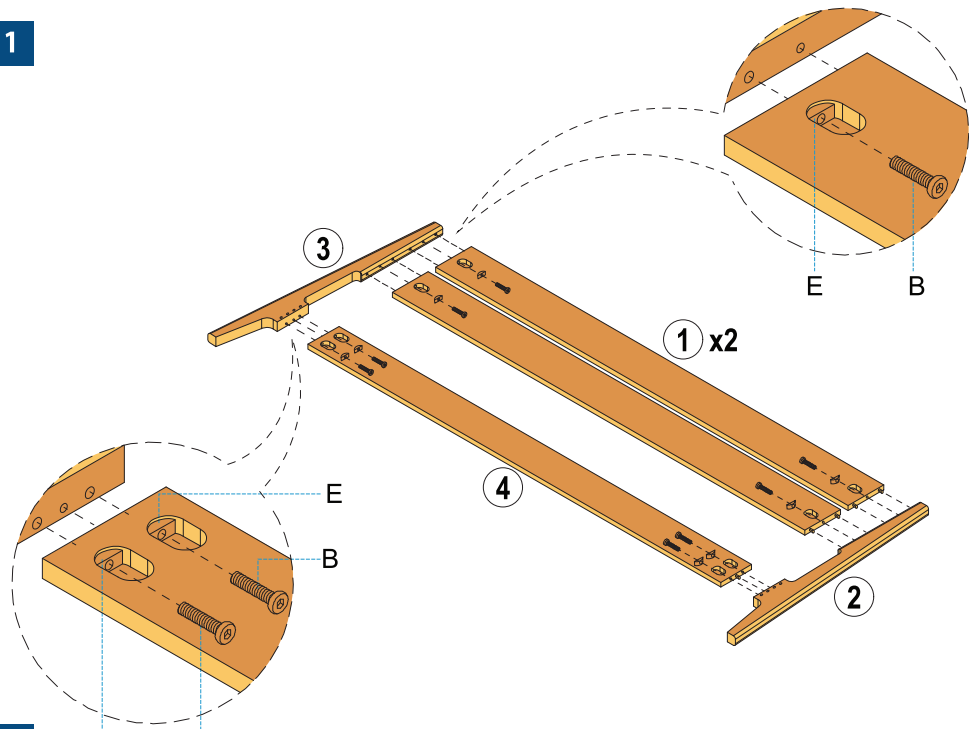

2

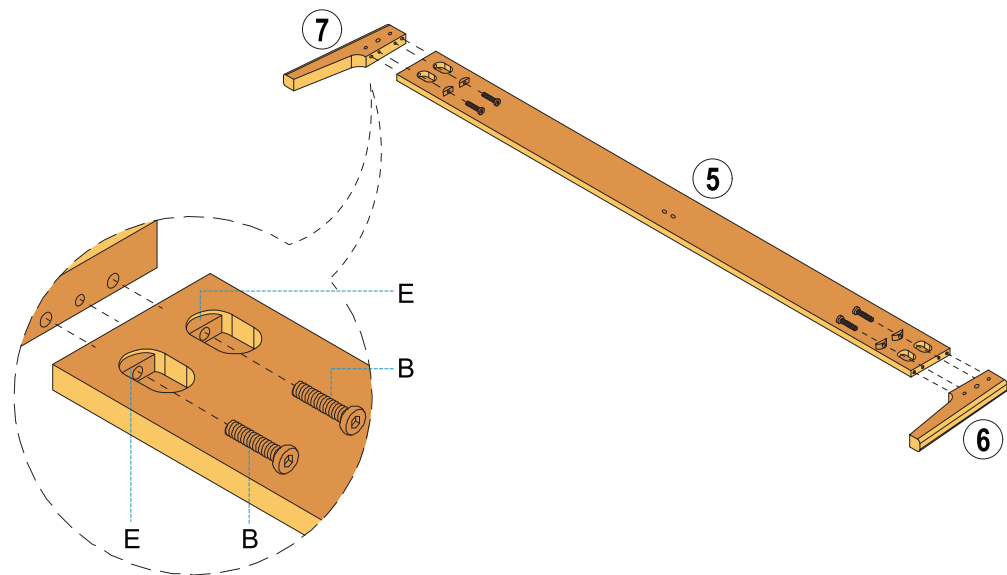

3

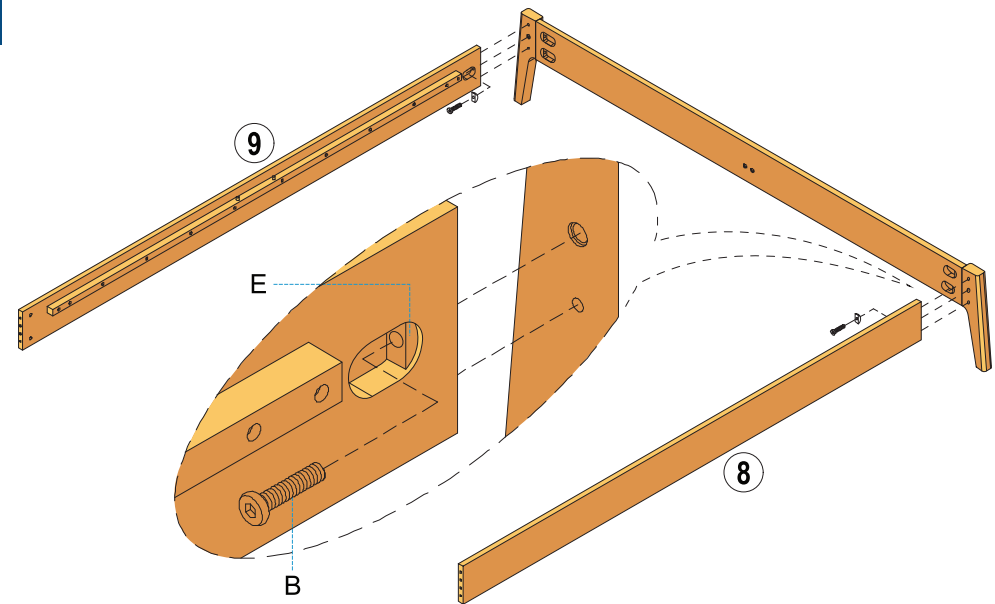

4

