

Assembly Instructions

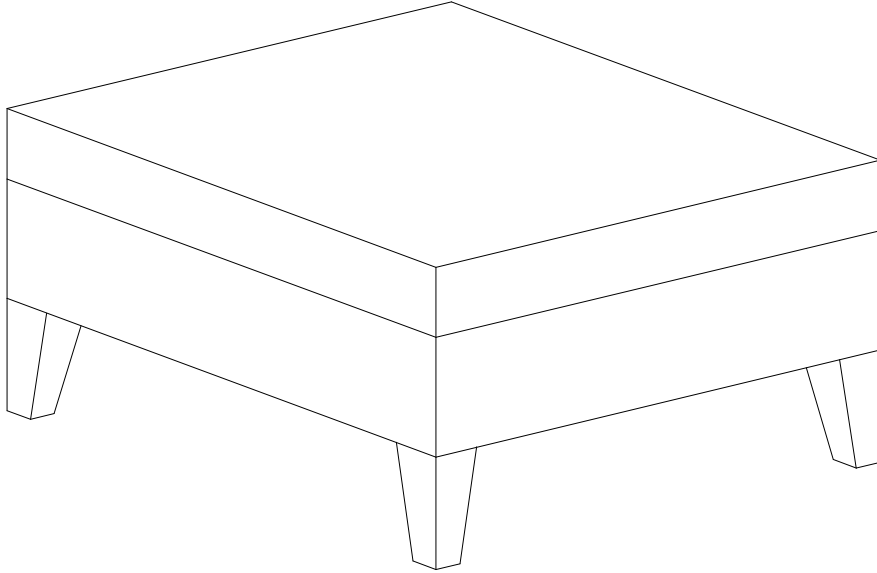

***Don't fully tighten all the bolts till the very end!**

PRE-ASSEMBLY PREPARATION:

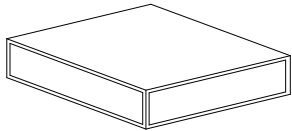
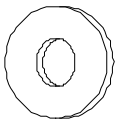
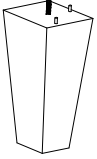
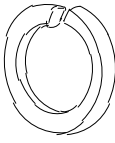
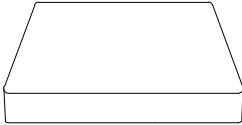
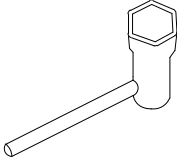
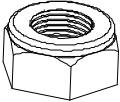

- Please read through the instructions before beginning assembly.
- Clear out the space for assembly and lay out all of the parts based on the Parts List, extra room will allow you to easily determine if all the pieces are present.
- Keep small parts and pieces away from children until fully assembled.

Part no.	Part	QTY	Image	Part no.	Part	QTY	Image
A	Seat	1		E	Washer Ø18*Ø8.5*1mm	4	
B	Leg	4		F	Spring washer Ø8.5	4	
C	Cushion	1		G	Wrench	1	
D	Nut (M8)	4					

Step 1: Attach legs B to seat A with 4pcs washers E, 4pcs spring washers F and 4pcs nuts D, using wrench G.

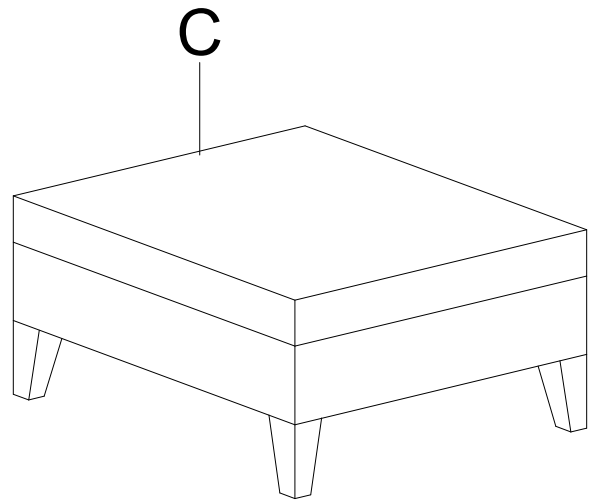
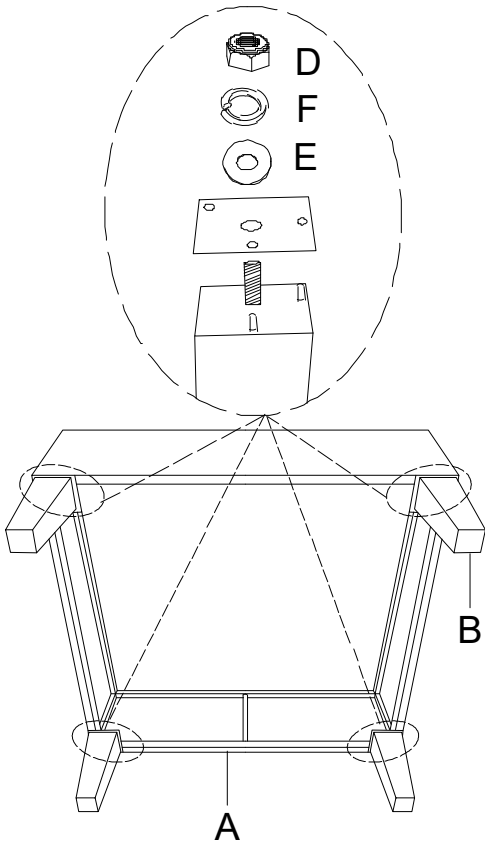
Step 2: Put the cushion C onto the seat. Assembly is now complete and the product is ready for use.



D		M8	4
E		Ø18*Ø8.5*1	4
F		Ø8.5	4