

# ASSEMBLY INSTRUCTIONS

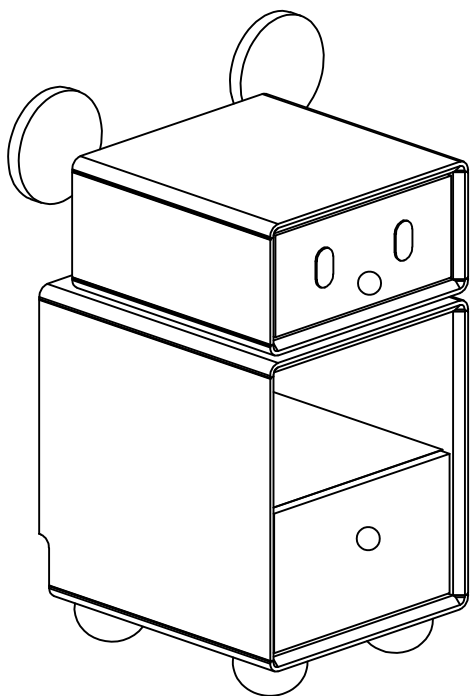



SKU CTG025-30CM

Model Nightstand 025







**IMPORTANT:** Before starting assembly, check that all parts and hardware match the list in the instructions. If any parts are missing or damaged upon arrival, contact us immediately. We'll respond within 24 hours to assist you.



## Part List

No.	Description	Pic	Dimension	Qty
1	Cabinet		300*350*510mm	1
2	Feet		∅80*50mm	4
3	Ears		∅130*14mm	2
4	Upper Drawer		266*260*116mm	1
5	Lower Drawer		266*260*159mm	1

## Hardware List

No.	Description	Pic	Dimension	Qty
A	Hexagon Socket Screw		M7*40MM	4
B	Hex Key Wrench		M4*57MM	1
C	Non-woven Mat		∅25*3MM	4
D	Sensor Light		∅85*22MM	1
E	Magnetic Sheet		30*30*2MM	1
F	Wooden Handle		∅25*22MM	2
G	Crossed Flat Head Screws		M4*25MM	2

This product has passed rigorous wood and paint inspections to meet national standards. It leaves the factory only after verifying the packaging is intact.

We value your feedback on our after-sales support. Please share your thoughts to help us improve!

Product Name	Wood Furniture	Standard: GB/T 3324 GB/ 18584	Required Workers		Inspector
Quality Certification	Pass				QC 02
Grade	Class 1				

# Model: Nightstand 025

## Step 1

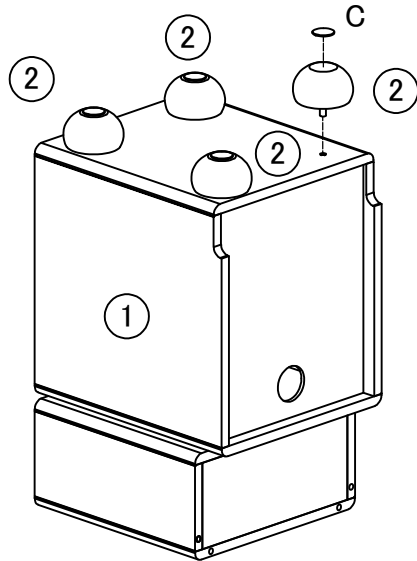

Screw part 2 clockwise to the bottom of part 1 as shown and attach hardware C.

## Step 2

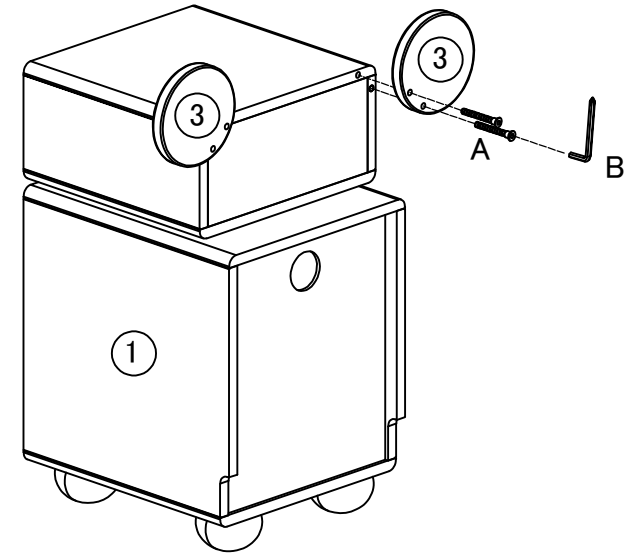

As shown, secure part 3 to the cabinet of part 1 with hardware A/B.

## Step 3

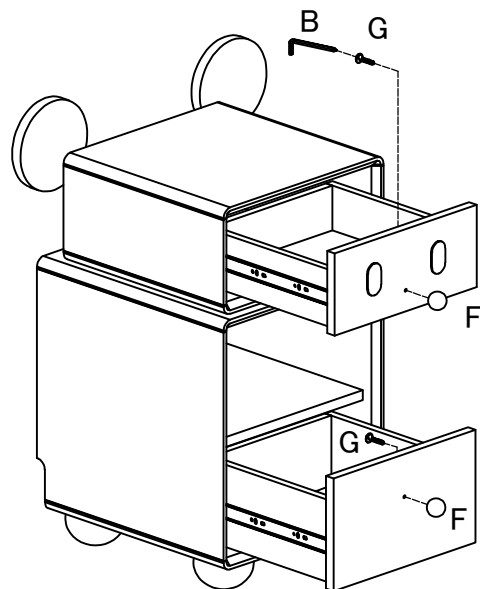

Pull out the drawers as shown and secure part F to the front panel of each drawer with hardware B/G.

## Step 4

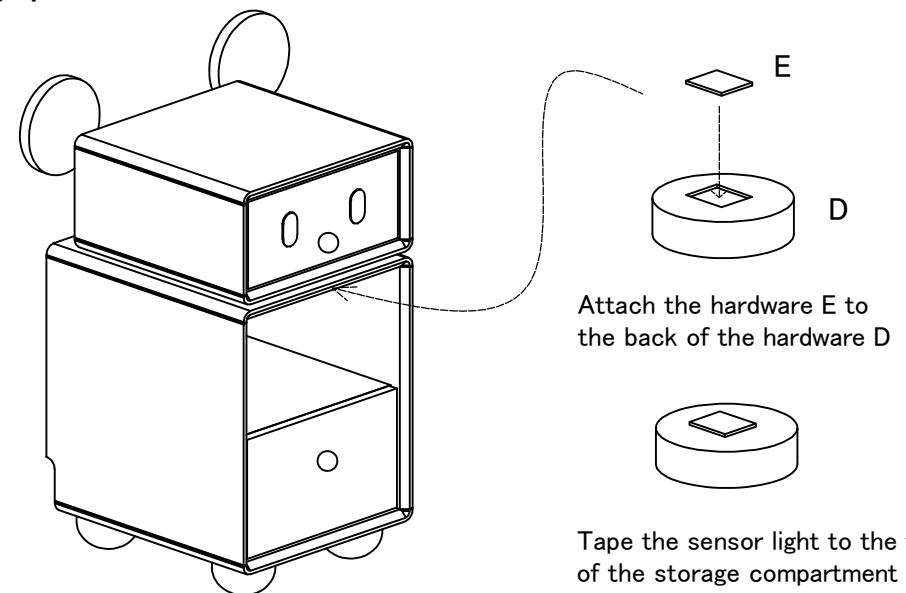

Attach the hardware E to the back of the hardware D

Tape the sensor light to the top of the storage compartment as indicated by the arrow

Install the sensor light as shown and the assembly is complete!