

Tools

Philips Screwdriver



Allen Key (supplied)



Check List

Familiarise yourself
with the contents



Check there is nothing
missing



Check you have all the
tools required



Make room to assemble
the product



Assembly Instructions

Before starting to assemble this unit please read the step by step assembly instructions carefully.

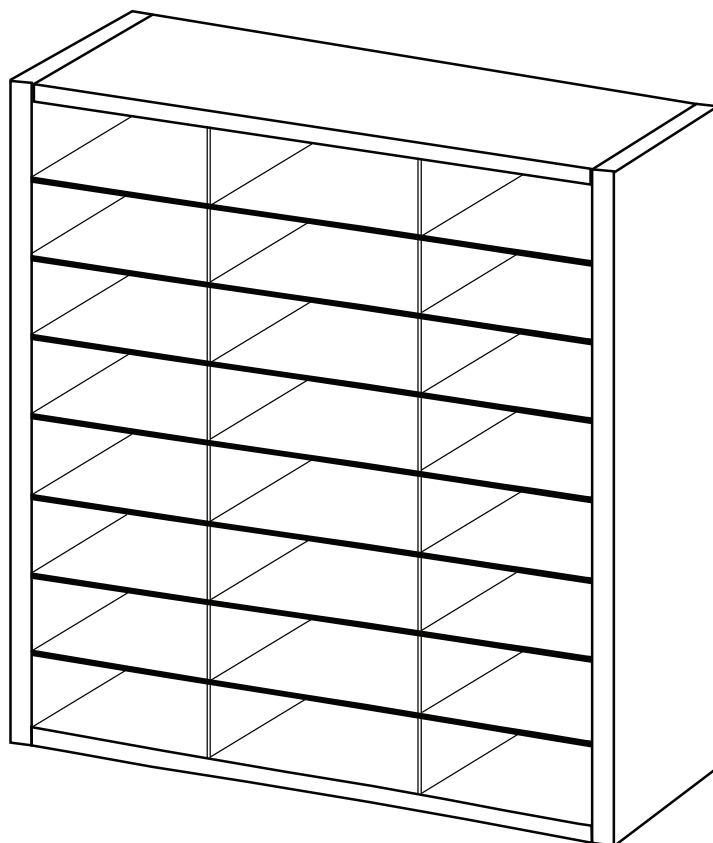

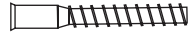
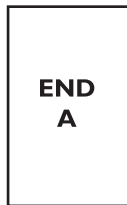
Components**Quantity****Confirmat Screws****12****Screw Caps****12****Trims****7****3/4" Nails****40****Allen Key****1****Panels****Quantity****Size (mm)****2****598x300mm****2****704x300mm****3****593x243mm**

Step 1

Secure ends A to top and bottom using (12) Confirmat Screws.

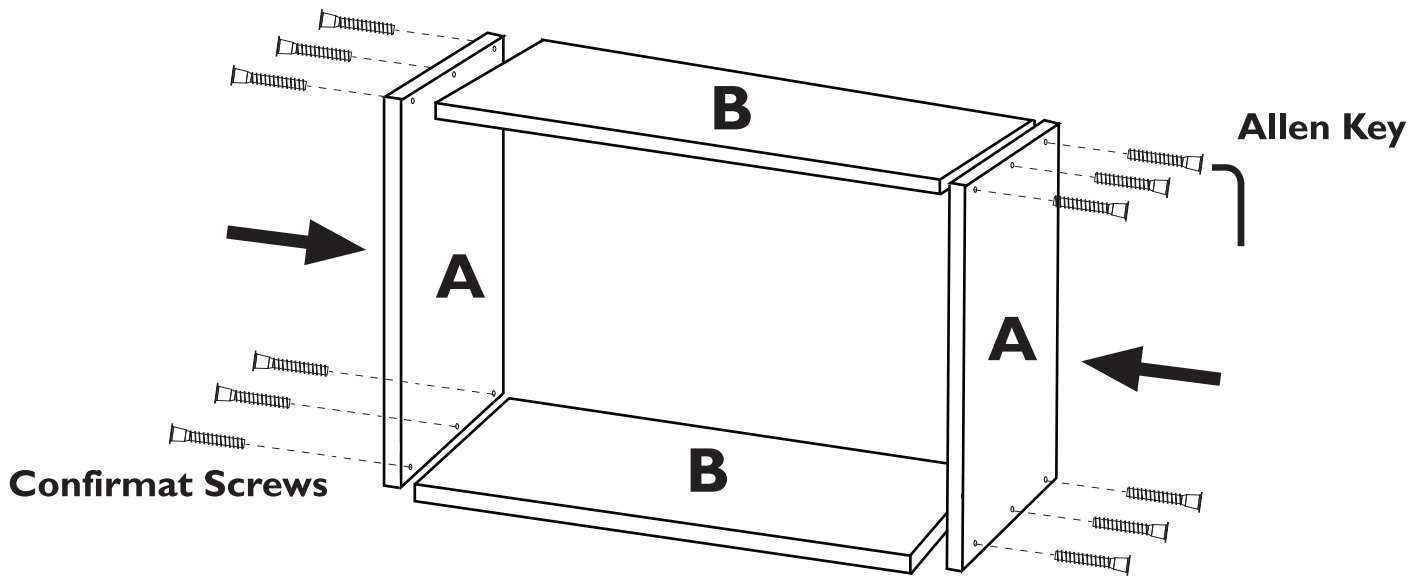

Step 2

Slot cardboard partitions together as shown.

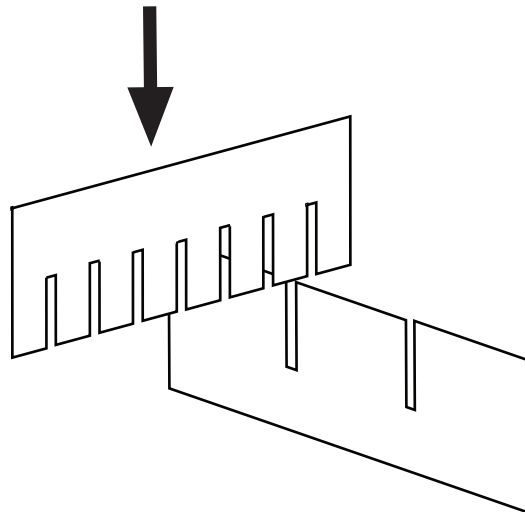

Step 3

Position end partitions - flex partition 'tails' inwards.

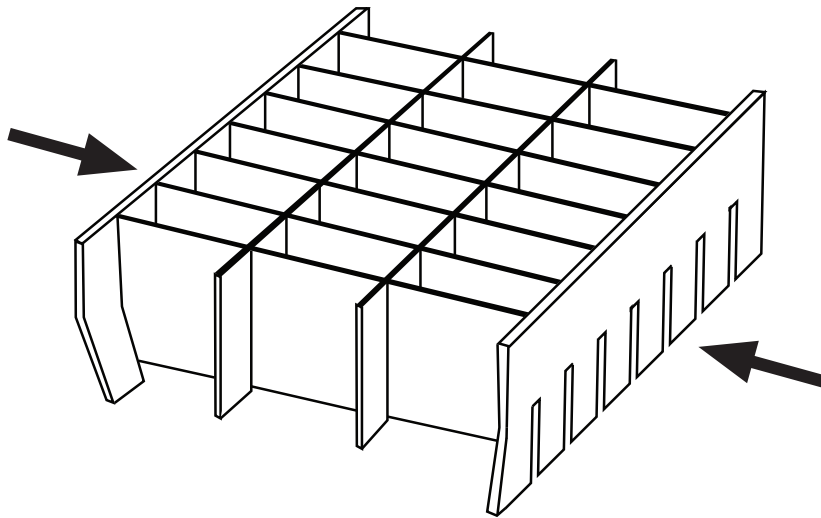

Step 4

Position unit face up on floor. Lower partition assembly into the unit and slide a channel on to partition before partition is flush with ends.

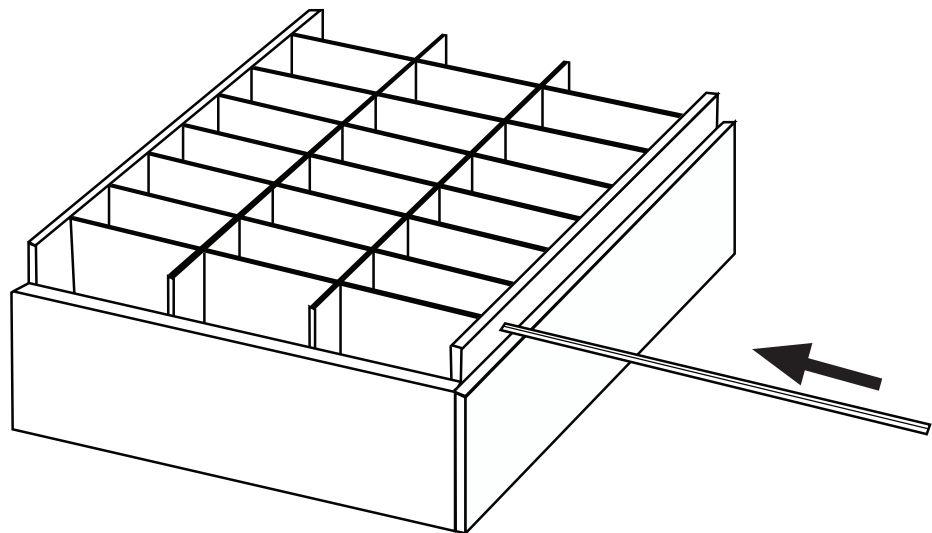

Step 5

Carefully turn unit over. Position back panels as shown and secure with nails.

