

Assembly Instructions

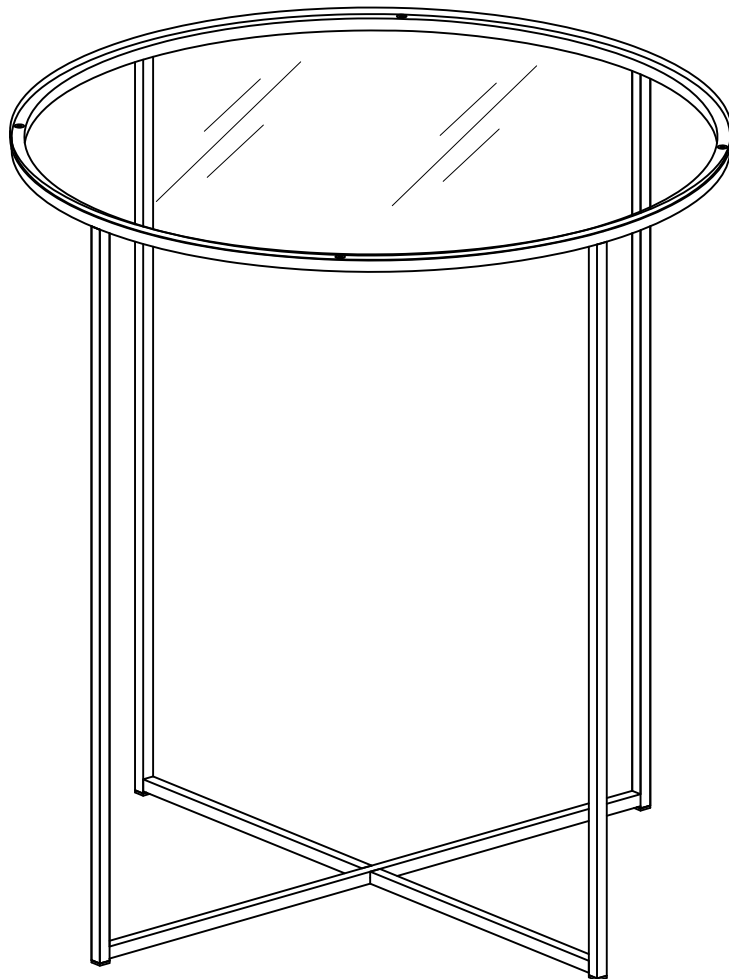

Parts List

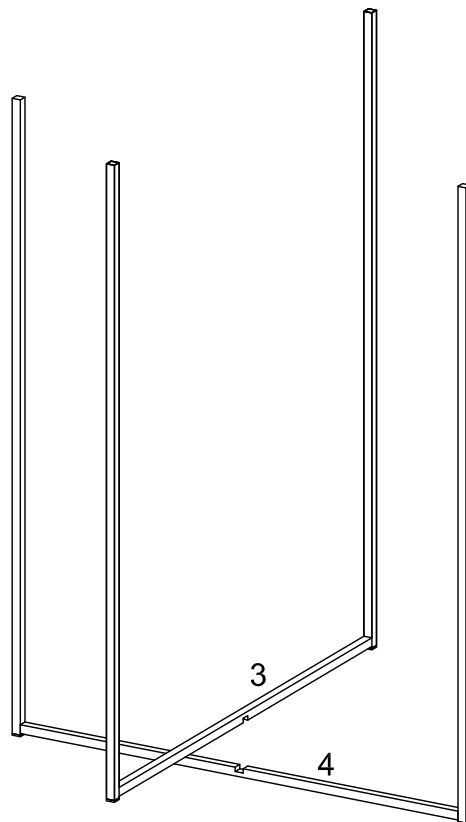
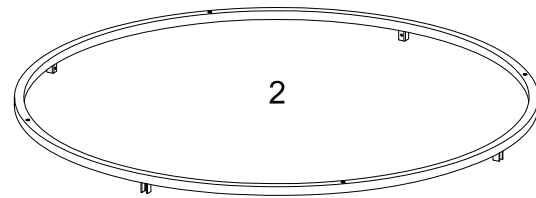
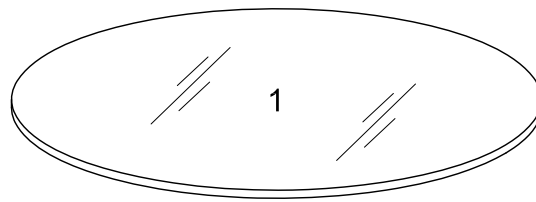

Hardware List

A		M6x10mm	Bolt	5 pcs
B			Rubber suction cups	4 pcs
C		M4mm	Wrench	1 pc

Step 1

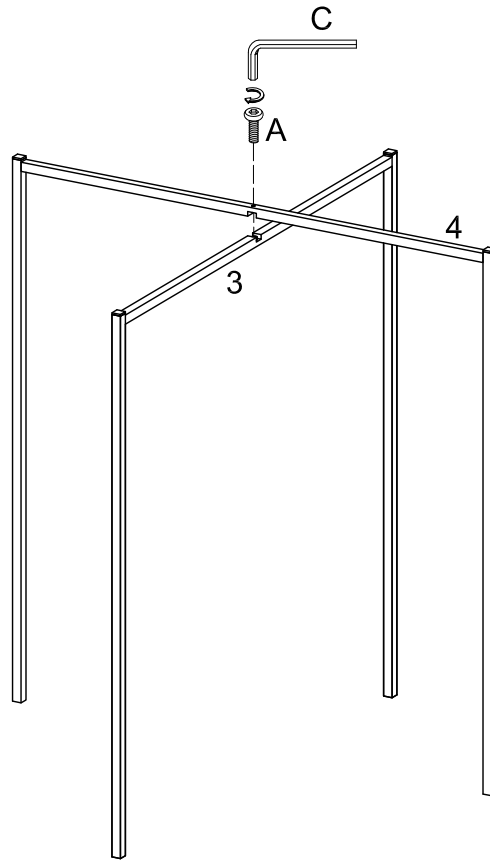

Use wrench (C), bolt (A) to secure the leg (3,4).

Step 2

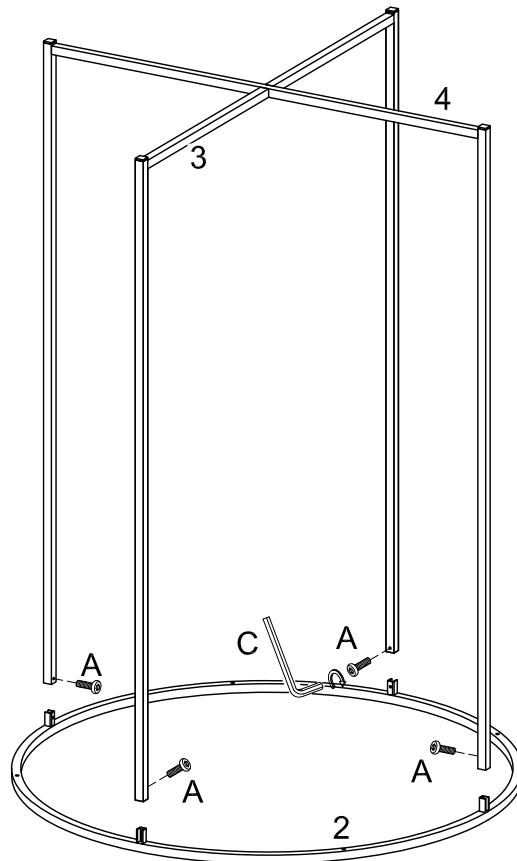

Use wrench (C), bolt (A) to secure the leg (3,4) to the table top frame (2).

Step 3

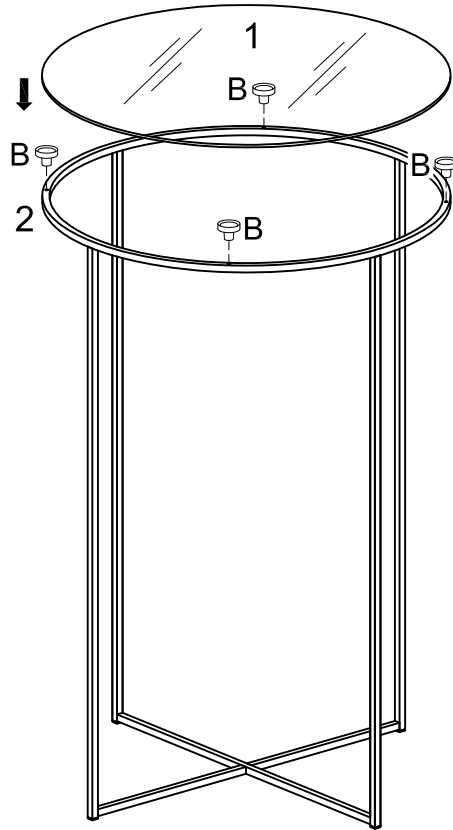

Insert the rubber suction cup (B), then place the glass (1) carefully on top of table top frame (2).

Step 4

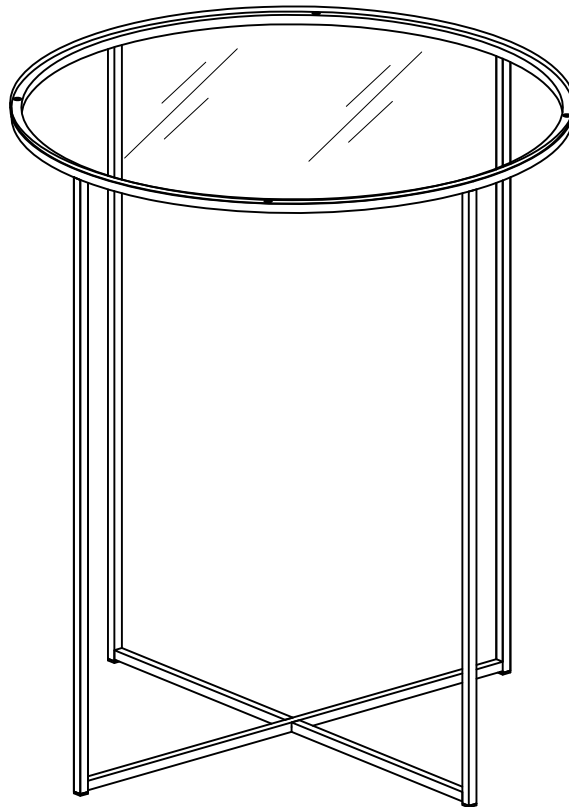

Final Assembly