

# ASSEMBLY INSTRUCTIONS

## PARTS AND FITTING PACKAGING DETAIL

### BOX #1

A. UNIT 1PC

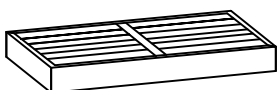

B. STAND 1PC

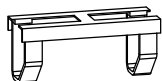

C. WHEEL 2PCS  
BRACKET







D. WHEELS 2PCS

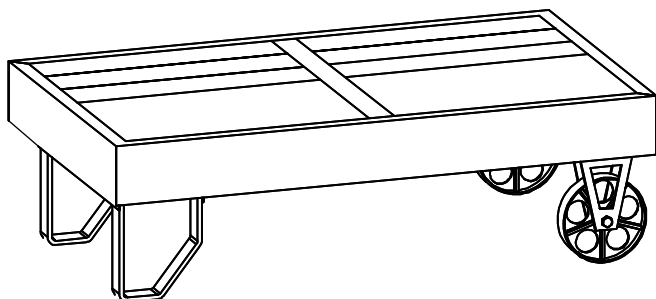

### TABLE ASSEMBLED

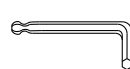

### HARDWARE \* PACKED IN BOX #1

H1	BOLT 8 X 30mm	12PCS	H2	WHEEL AXEL 25 X 80mm	2 PCS
					
H3	FLAT WASHER 2 X 14 X 32mm	2 PCS	H4	NUT 14 X 6mm	2 PCS
					
H5	HEX WRENCH 23mm	1 PC	H6	ALLEN KEY M4	1 PCS
					

YOUR BOX MAY CONTAIN EXTRA HARDWARE

### STEP 1

Attach the Stand (B) to the bottom of the Unit (A) with Bolts (H1). Tighten with Allen Key (H6).  
NOTE!: Stand can be installed on either side of the Unit.

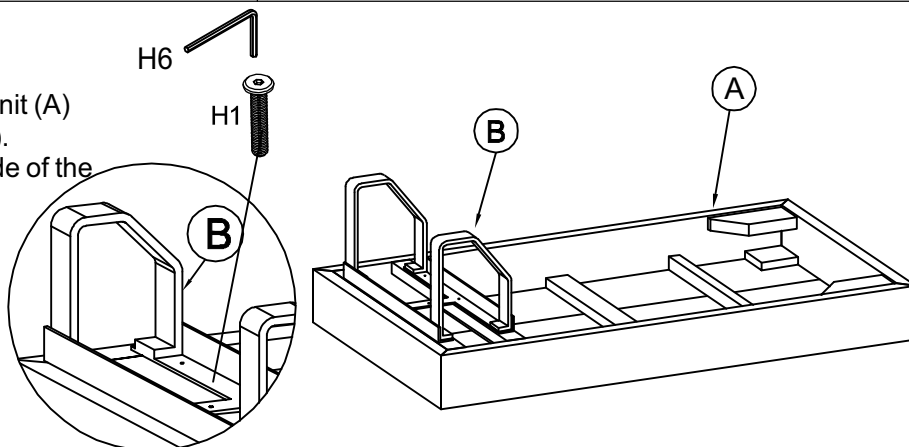

### STEP 2

Attach both Wheel Brackets (C) to the Unit with Bolts. Tighten with Allen Key (H6).

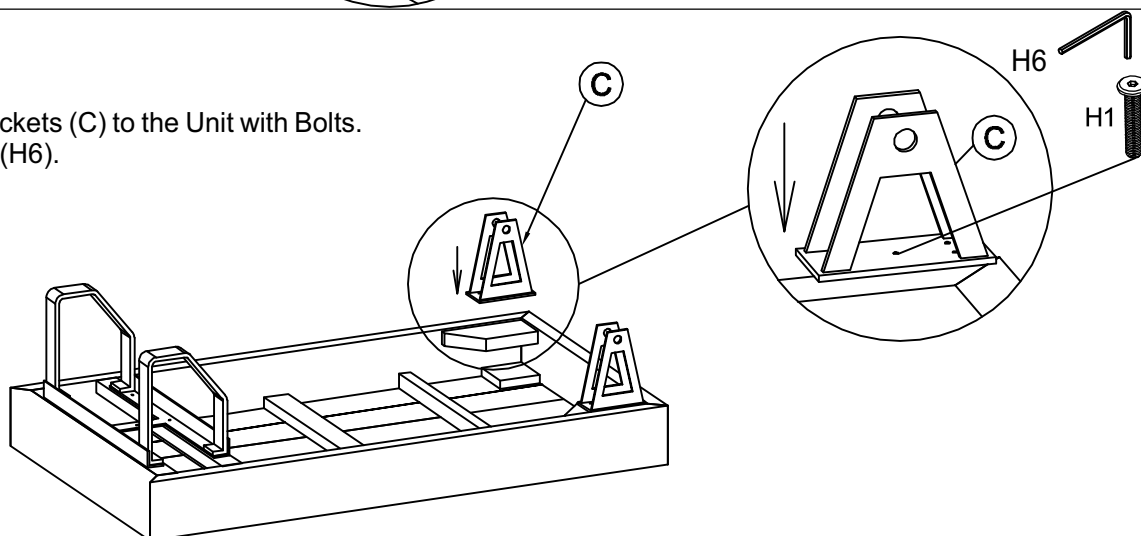

# COALBURN COFFEE TABLE

## ASSEMBLY INSTRUCTIONS



### STEP 3

Attach Wheels (D) to Wheel Brackets (C) using Wheel Axels (H2), Flat Washers (H3) and Nuts (H4). Tighten each Nut with Hex Wrench (H5). Flip Unit right-side up and assembly is complete.

