

# ASSEMBLY INSYRUCTIONS

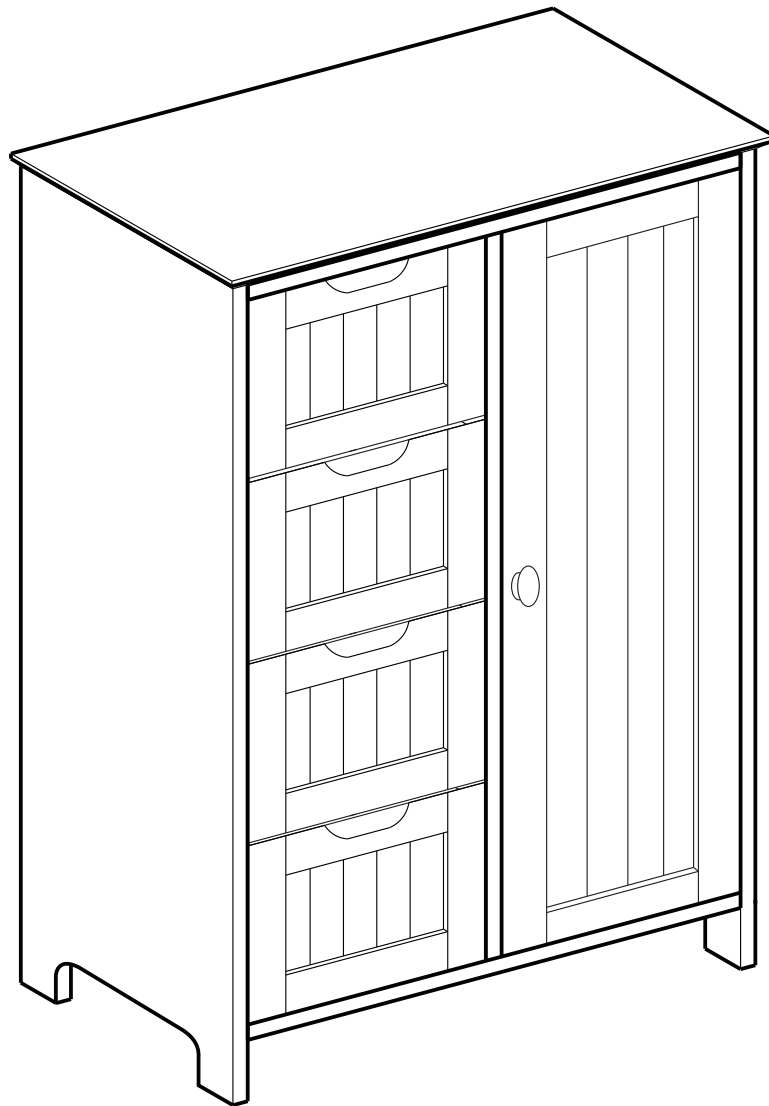

**A**

× 1

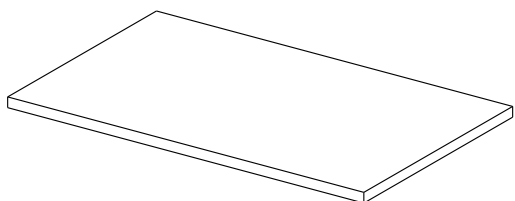

**B**

× 1

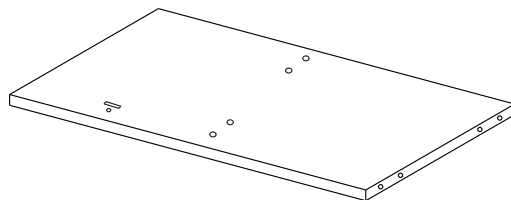

**C**

× 1

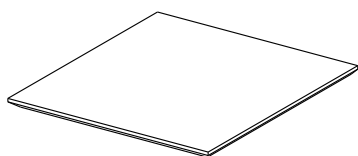

**D**

× 1

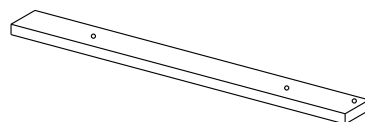

**E**

× 1



**F**

× 1



**G**

× 1

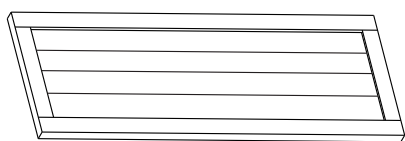

**H**

× 1

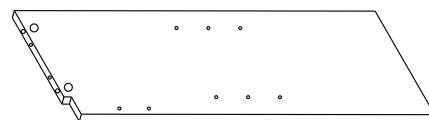

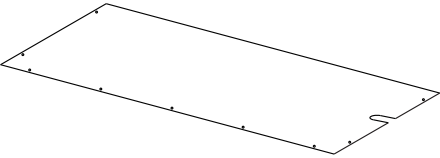
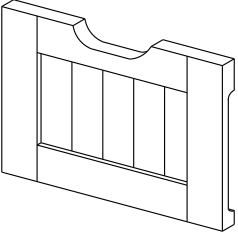
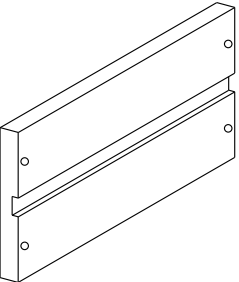
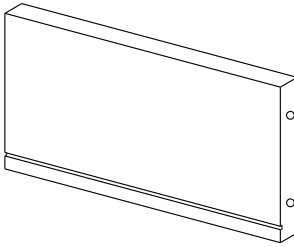
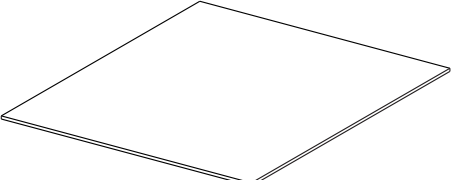
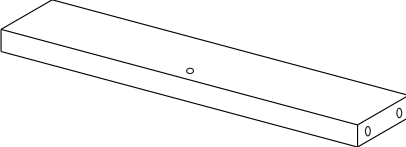
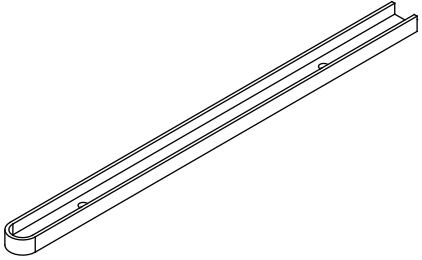
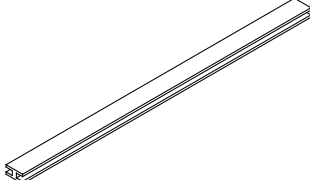
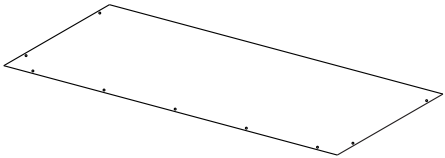
<p><b>I</b> × 1</p> 	<p><b>J</b> × 4</p> 
<p><b>K</b> × 8</p> 	<p><b>L</b> × 4</p> 
<p><b>M</b> × 4</p> 	<p><b>N</b> × 3</p> 
<p><b>O</b> × 8</p> 	<p><b>P</b> × 1</p> 
<p><b>Q</b> × 1</p> 	

1



18+1

2

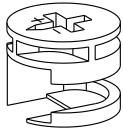

16+1

3

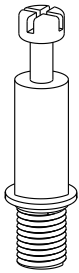

16+1

4



18+1

5

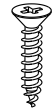

× 2

6

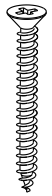

32+2

7

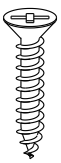

× 2

8

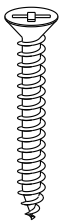

× 2

9

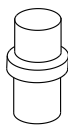

× 2

10

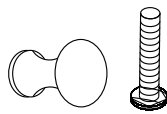

× 1

11

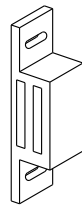

× 1

12

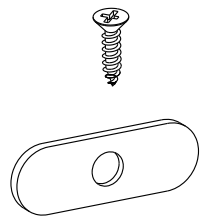

× 1

13

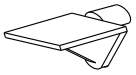

× 4

14

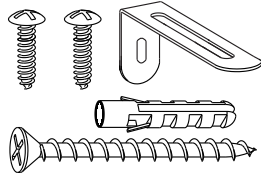

× 1

15

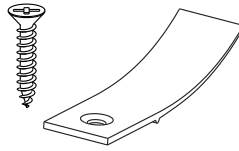

× 4

16



16+1

17

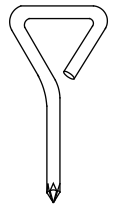

× 1

Tools Required:

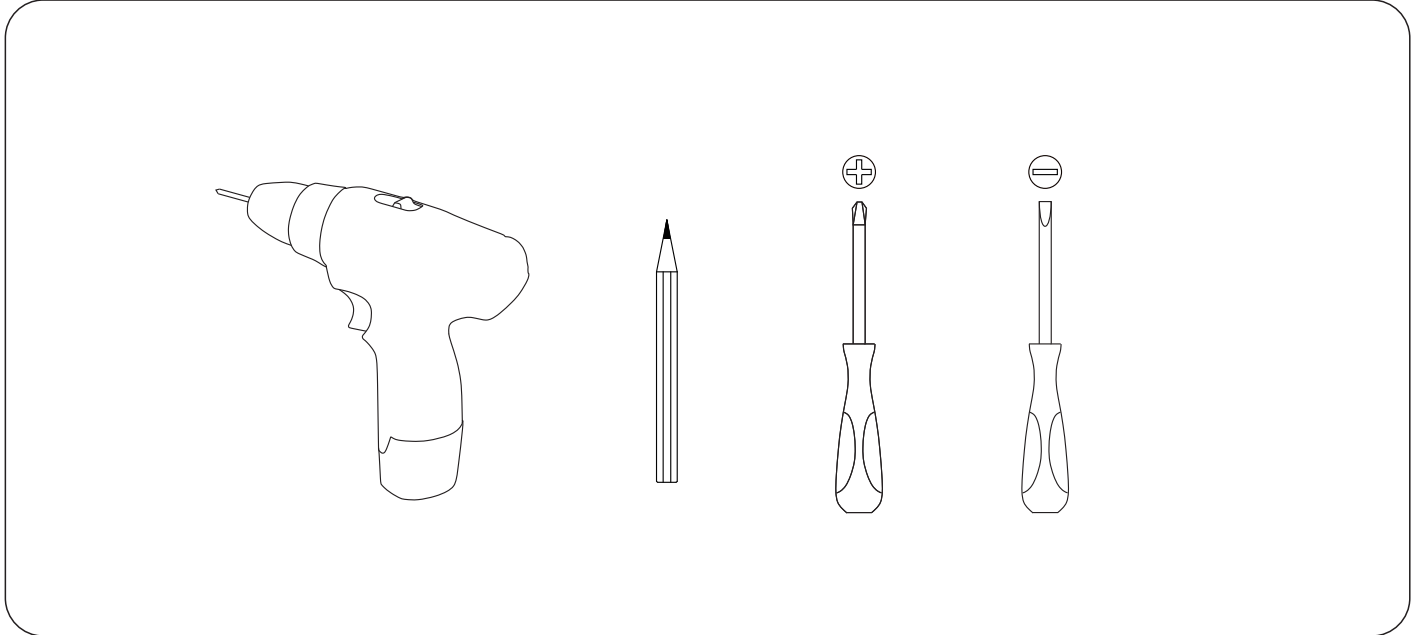

Make sure the pins are installed correctly as shown with the "check mark" below

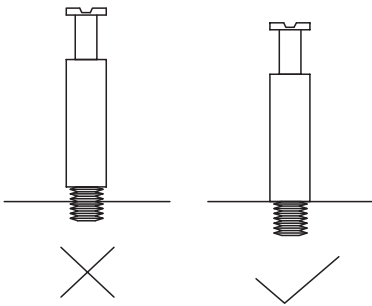

Below shows how the pins are used to assemble the panels together.

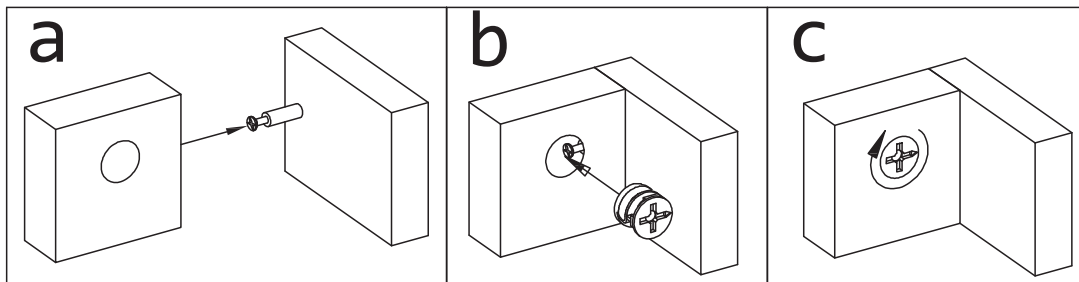

# STEP 1

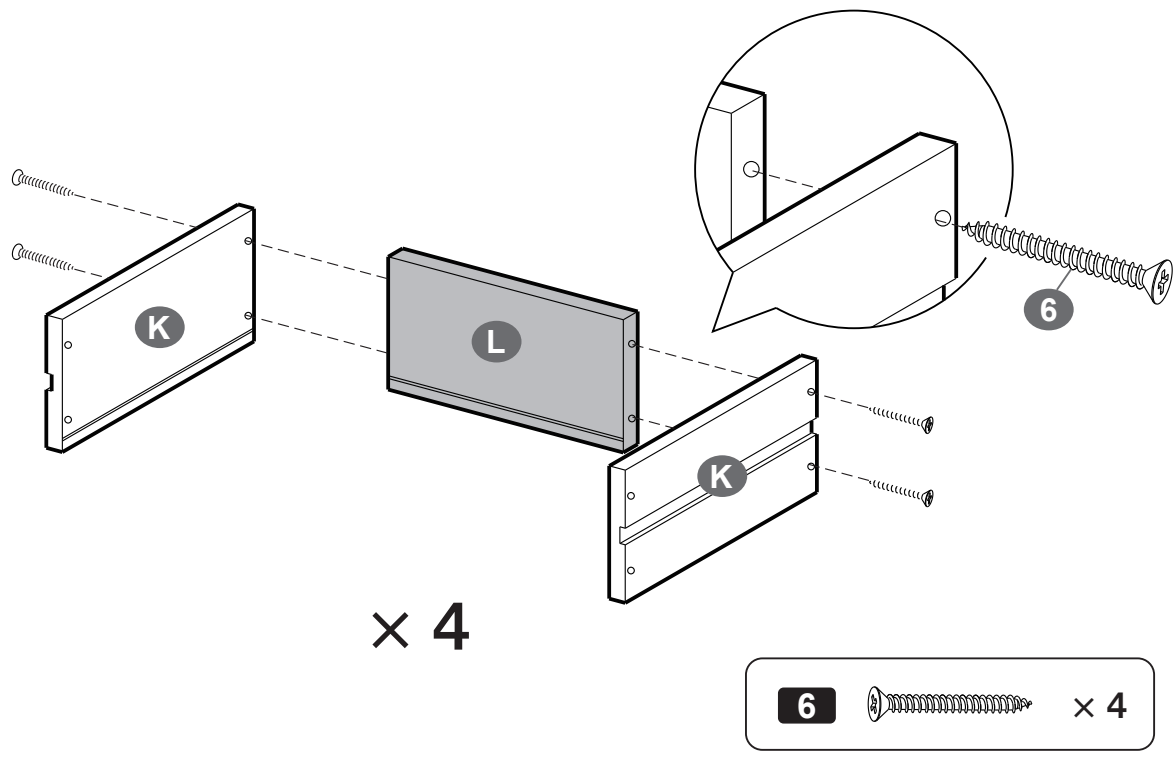

# STEP 2

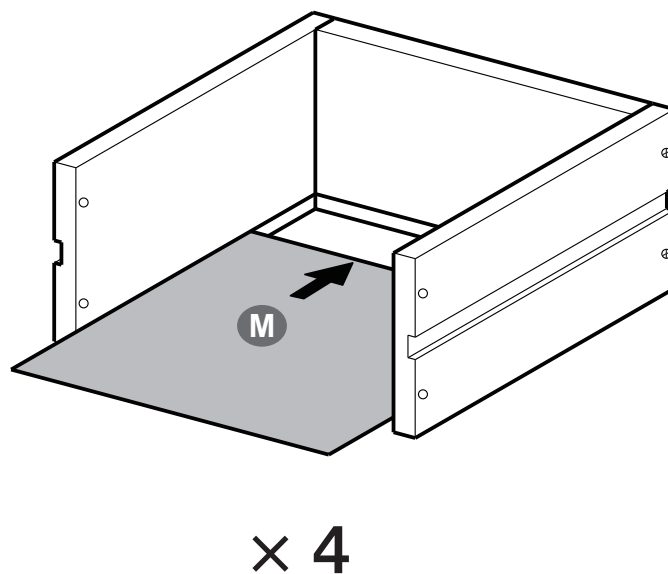

# STEP 3

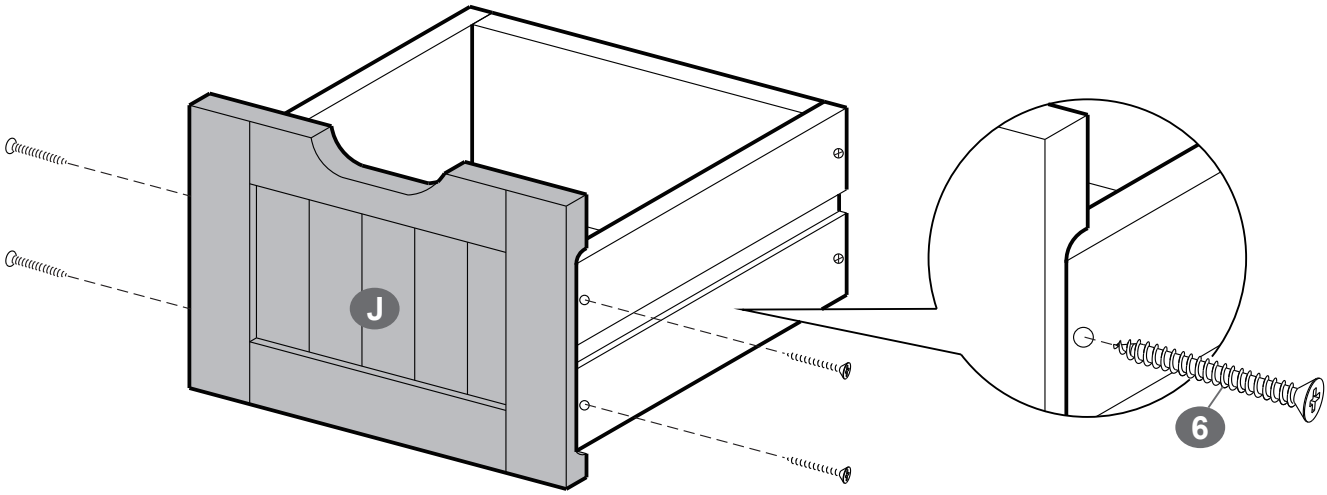

× 4



# STEP 4

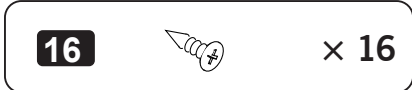
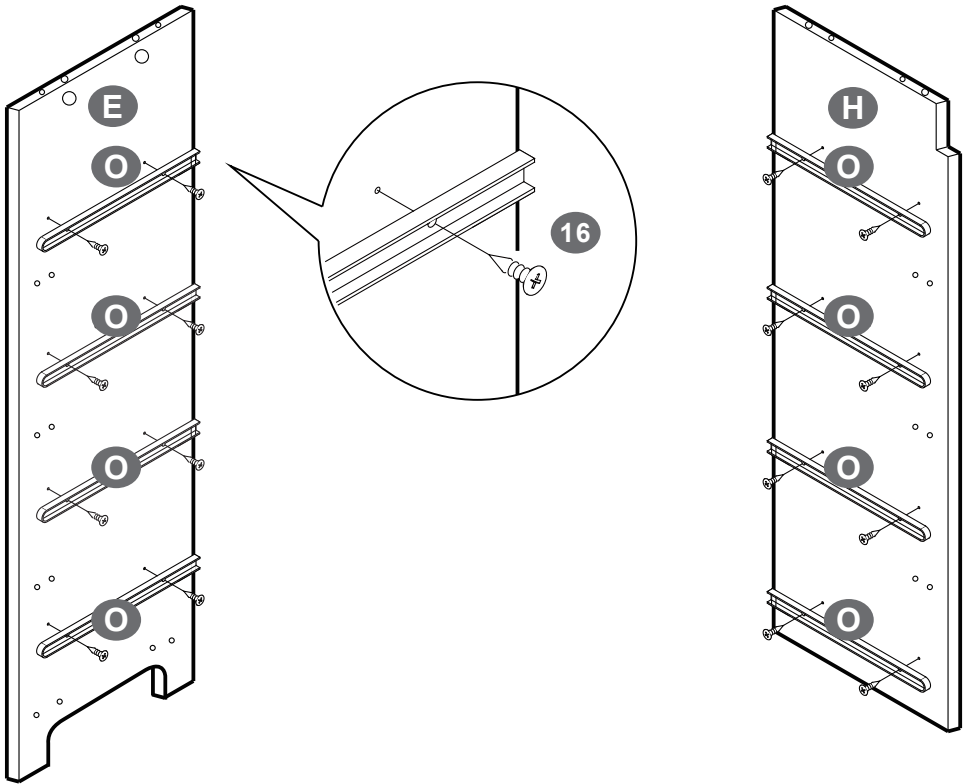

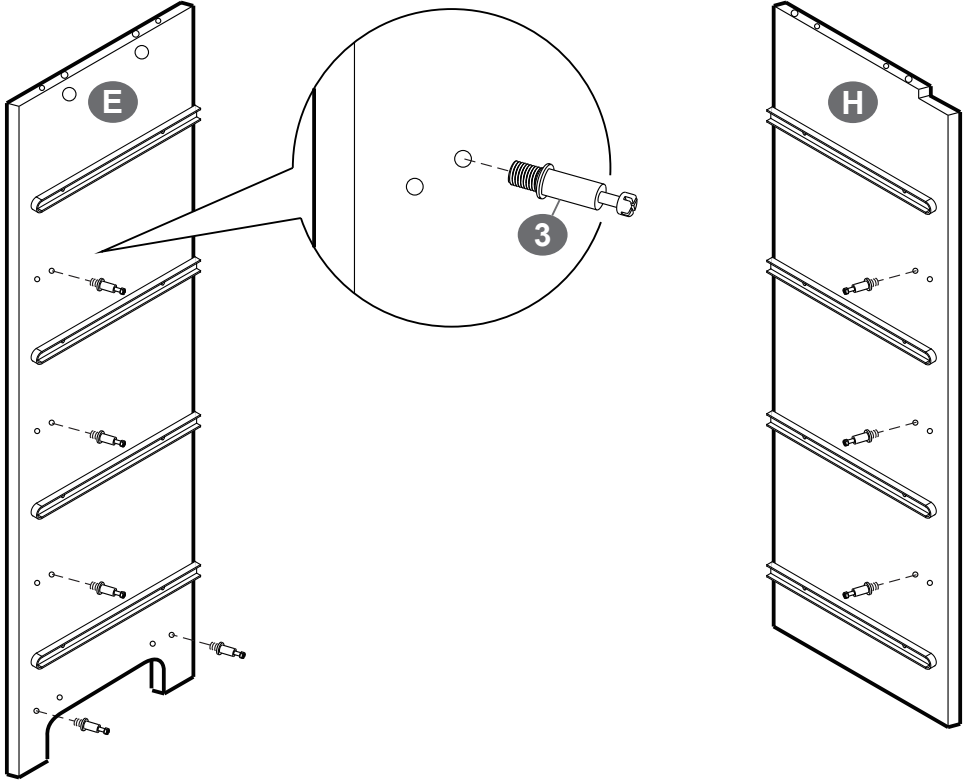

# STEP 5

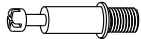

**3**  **× 8**

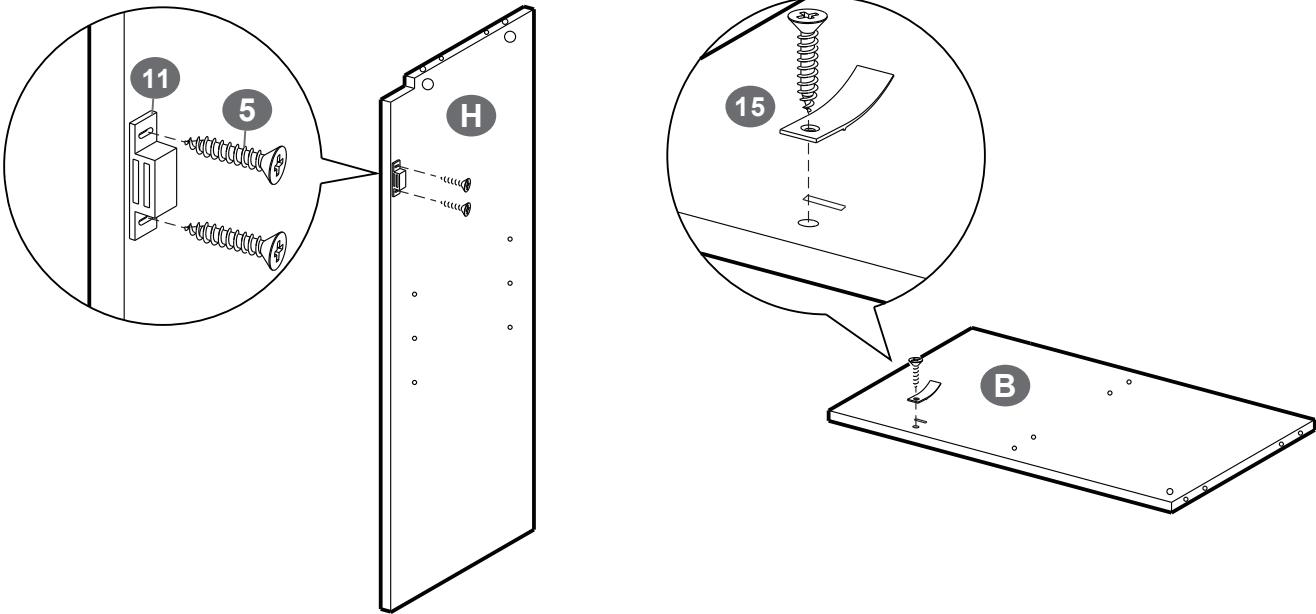

# STEP 6

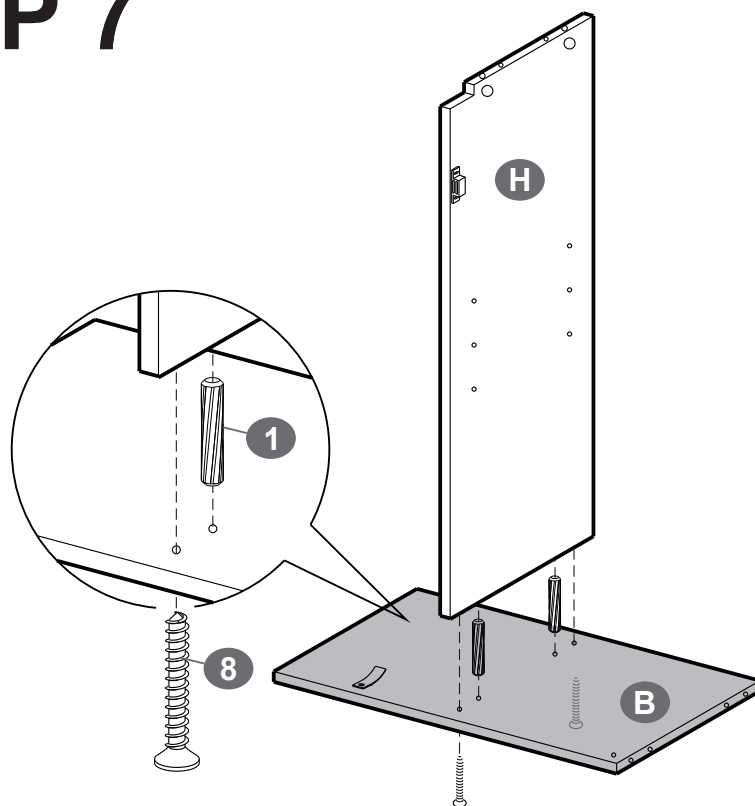

**5**  **× 2**

# STEP 7



<b>1</b>		× 2
<b>8</b>		× 2

# STEP 8

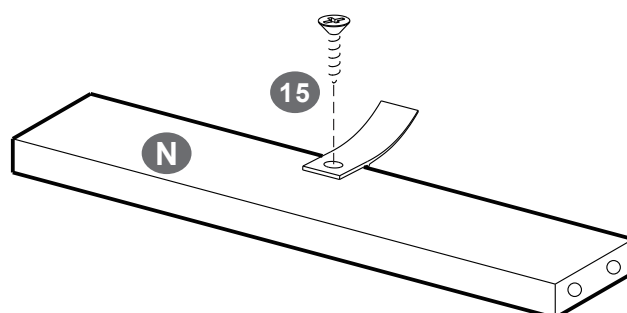

× 3

# STEP 9

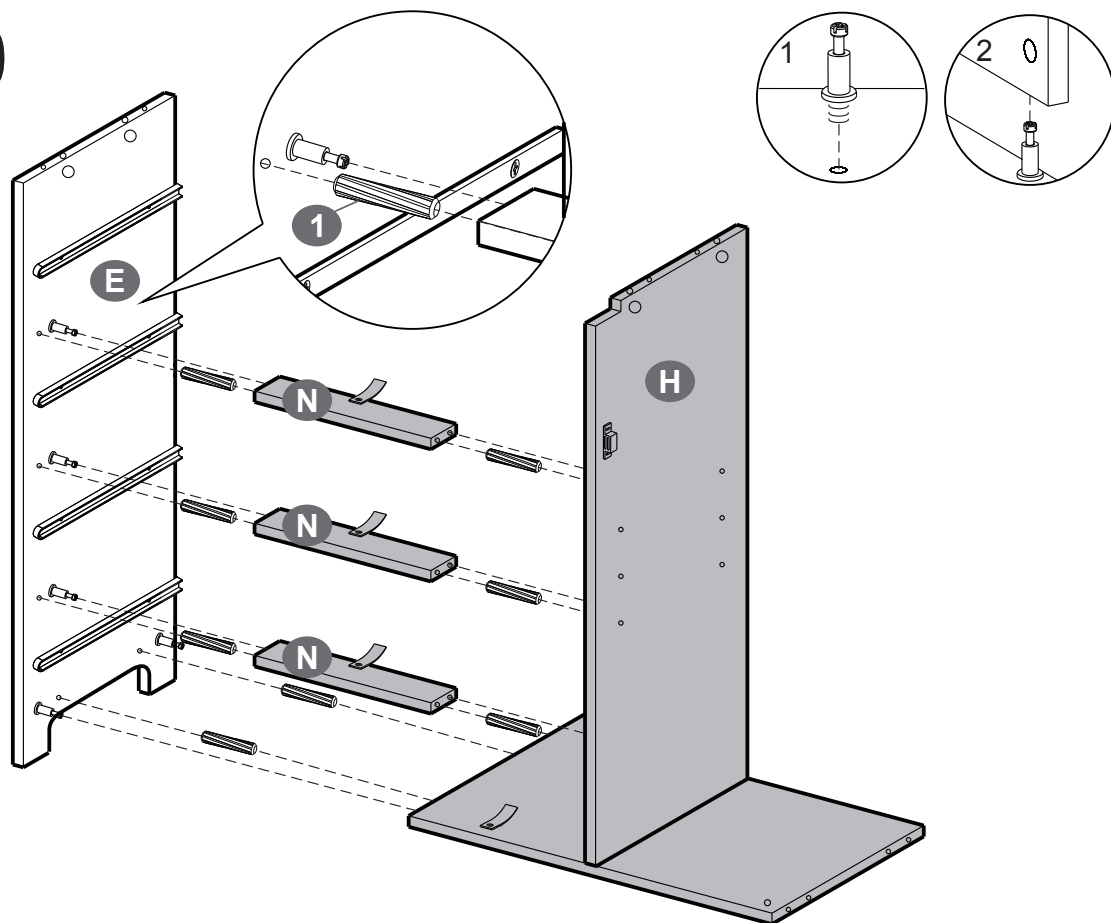

# STEP 10

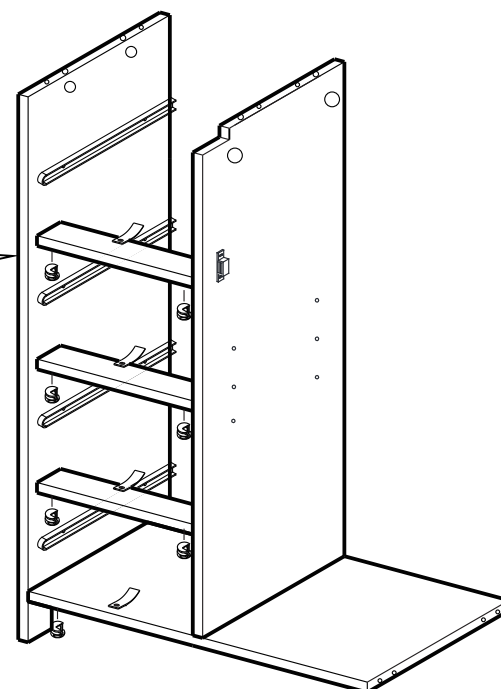
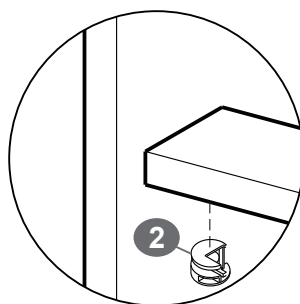
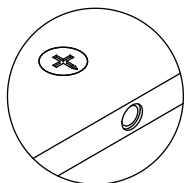
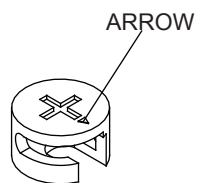
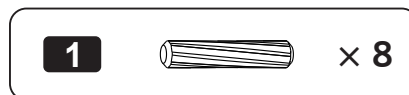

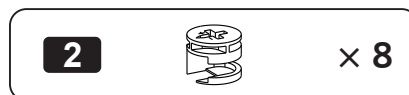

Push a CAM LOCK into the part.  
The arrow in the CAM LOCK must point  
toward the hole on the edge of the board.

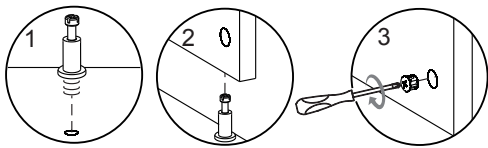
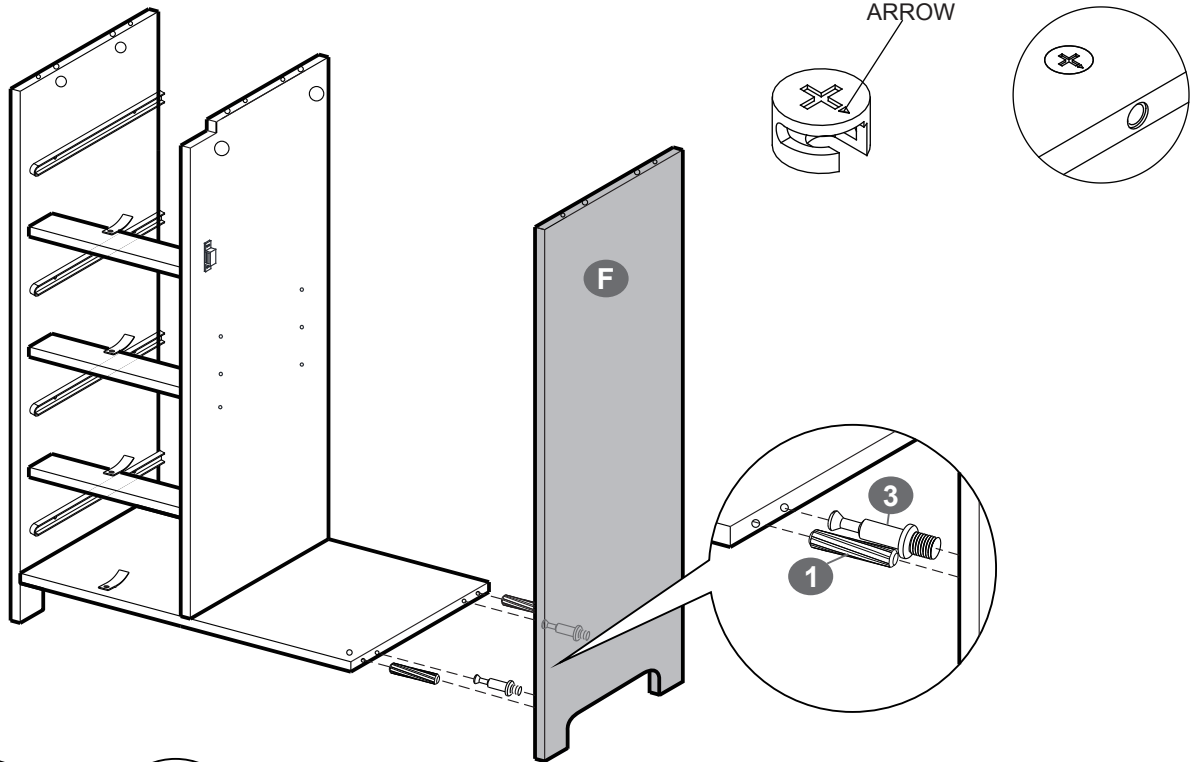

# STEP 11

Push a CAM LOCK into the part.  
The arrow in the CAM LOCK must point toward the hole on the edge of the board.



<b>1</b>		× 2
<b>3</b>		× 2

# STEP 12

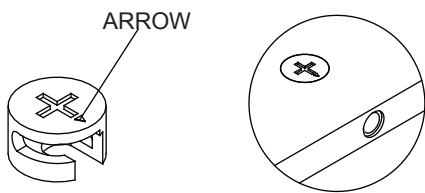
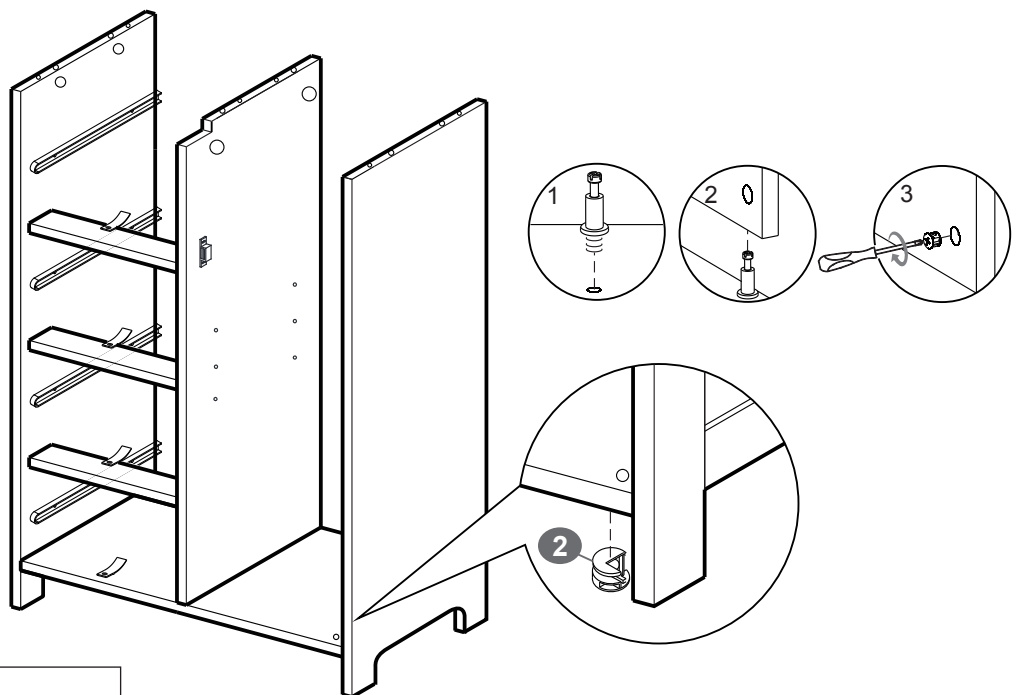

Push a CAM LOCK into the part.  
The arrow in the CAM LOCK must point toward the hole on the edge of the board.

<b>2</b>		× 2
----------	---	-----

# STEP 13

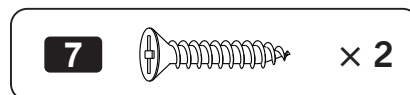
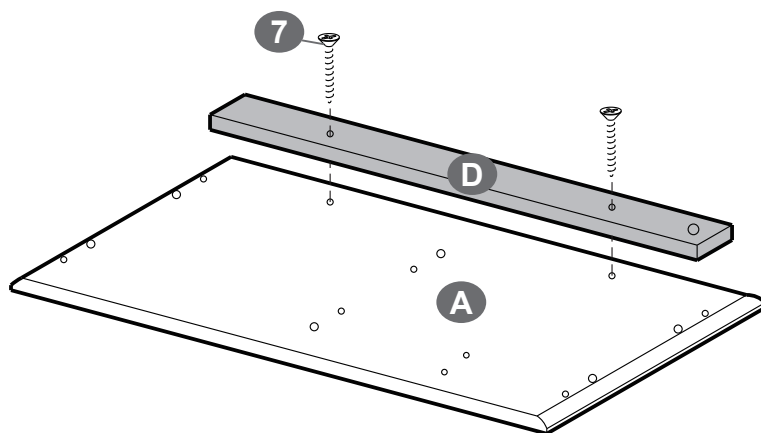

# STEP 14

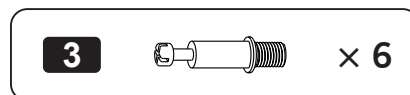
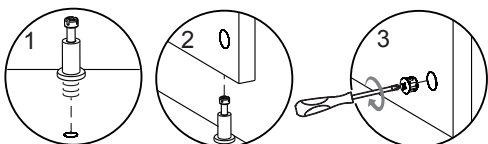
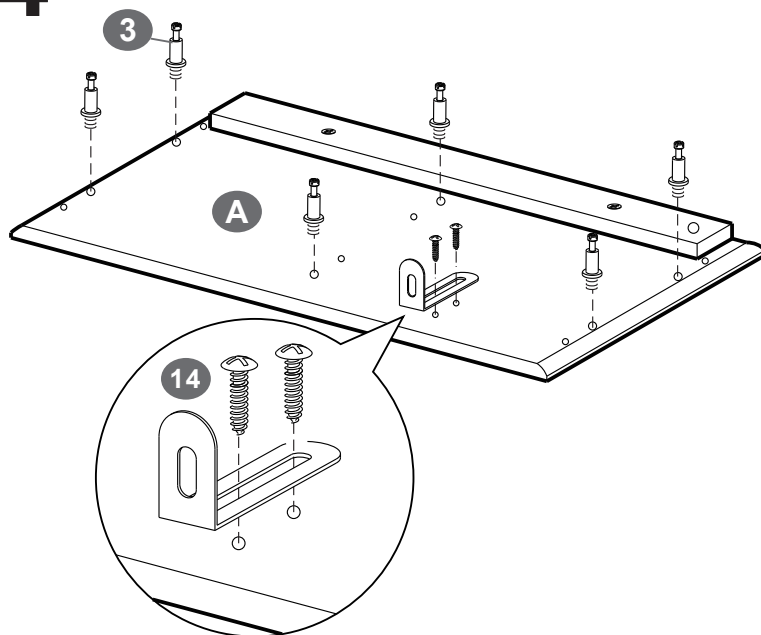

# STEP 15

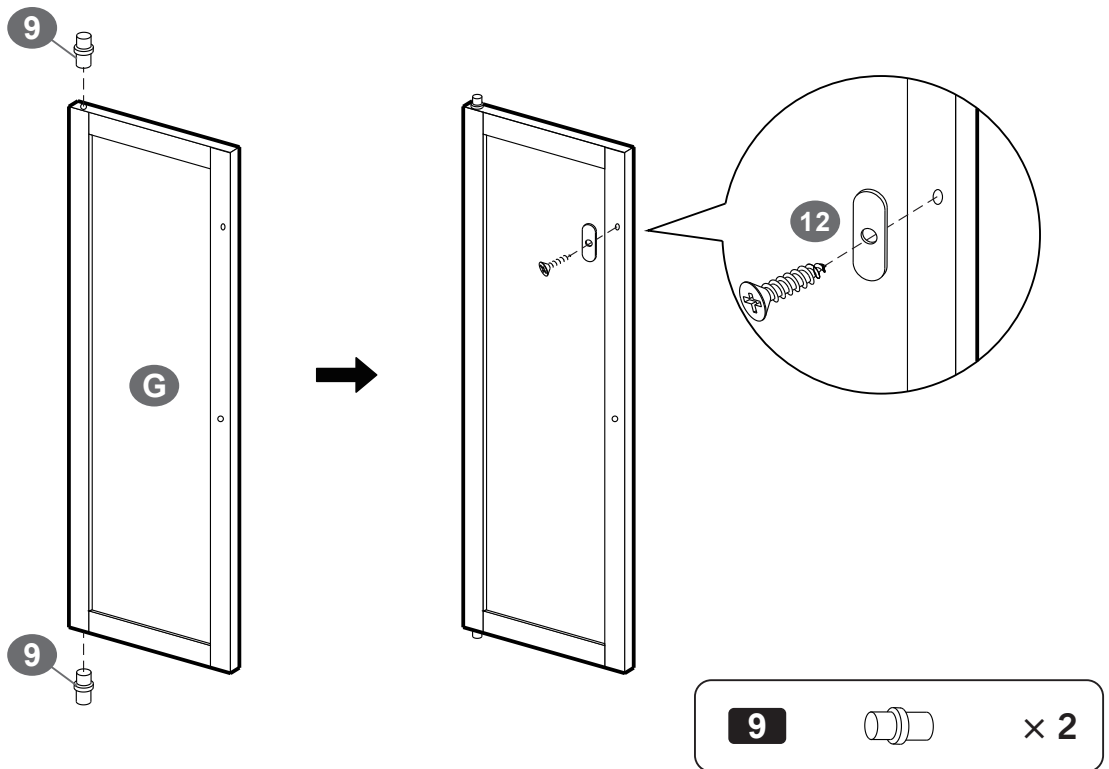

# STEP 16

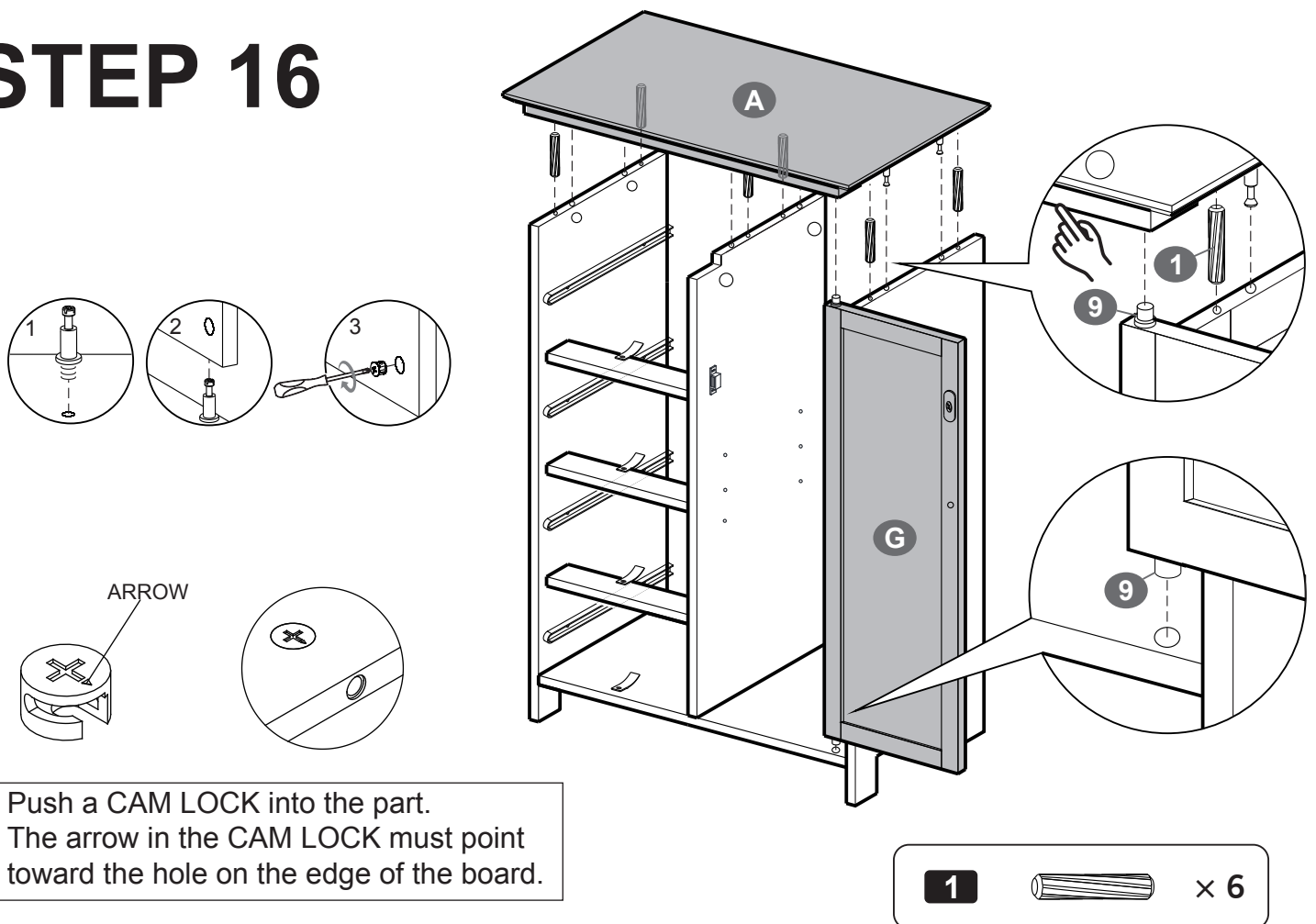

# STEP 17

Push a CAM LOCK into the part.  
The arrow in the CAM LOCK must point toward the hole on the edge of the board.

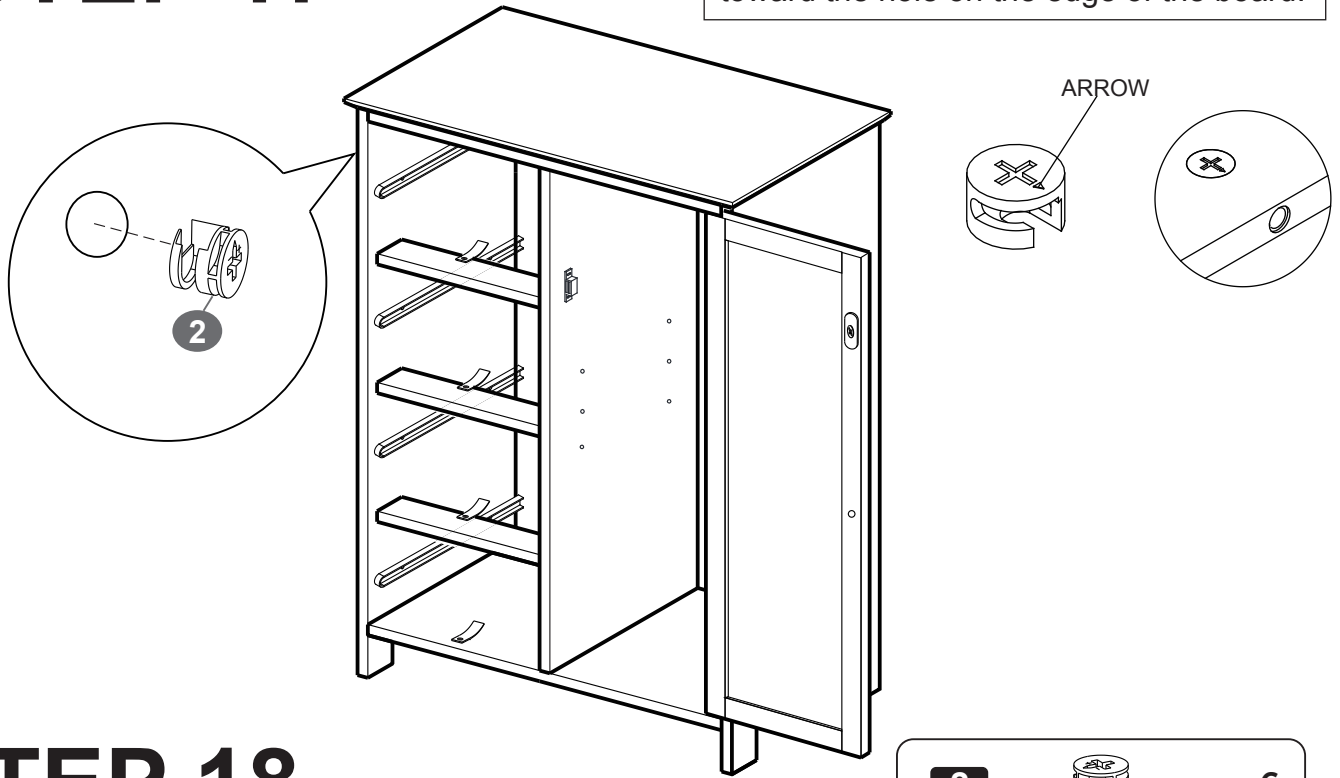

# STEP 18

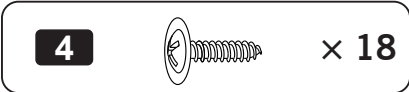
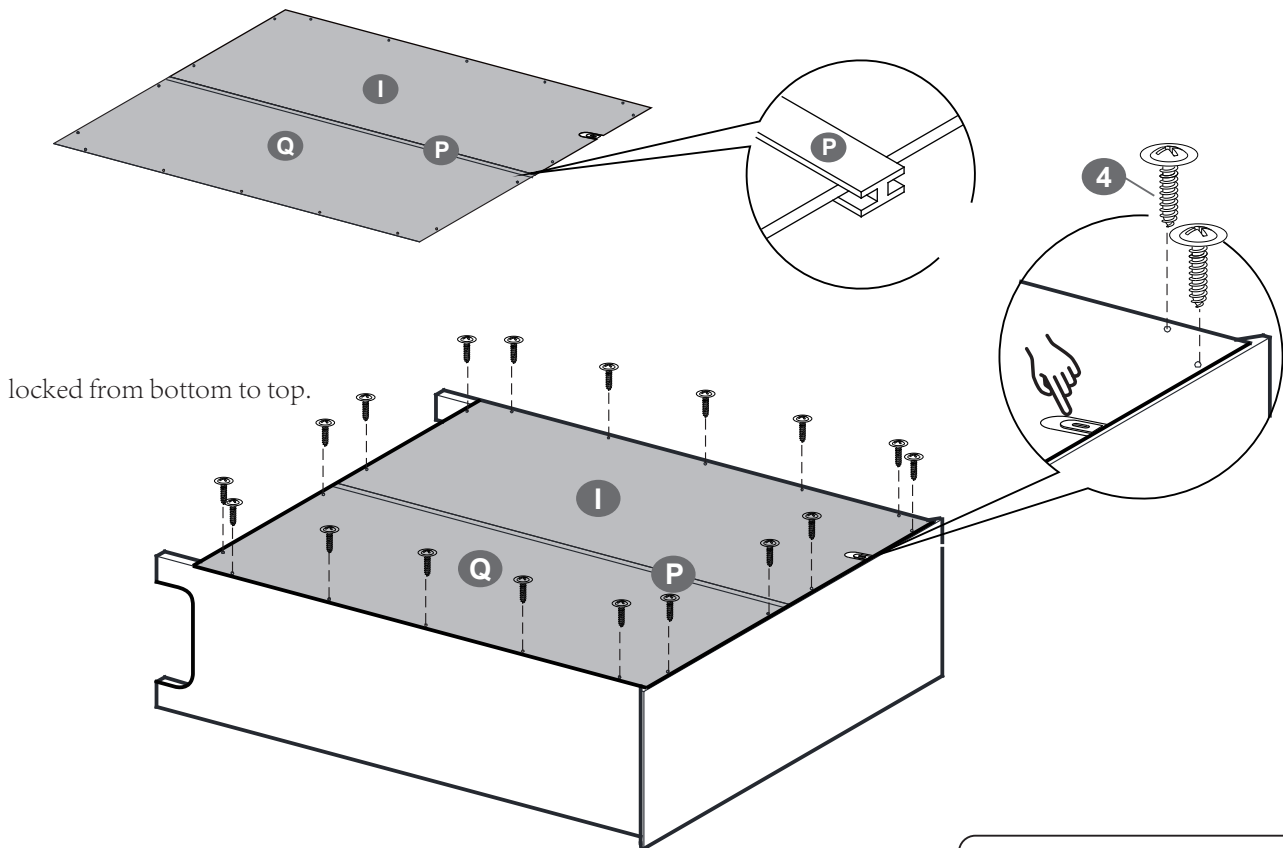
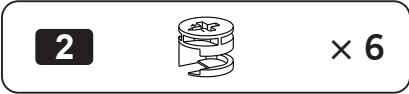

# STEP 19

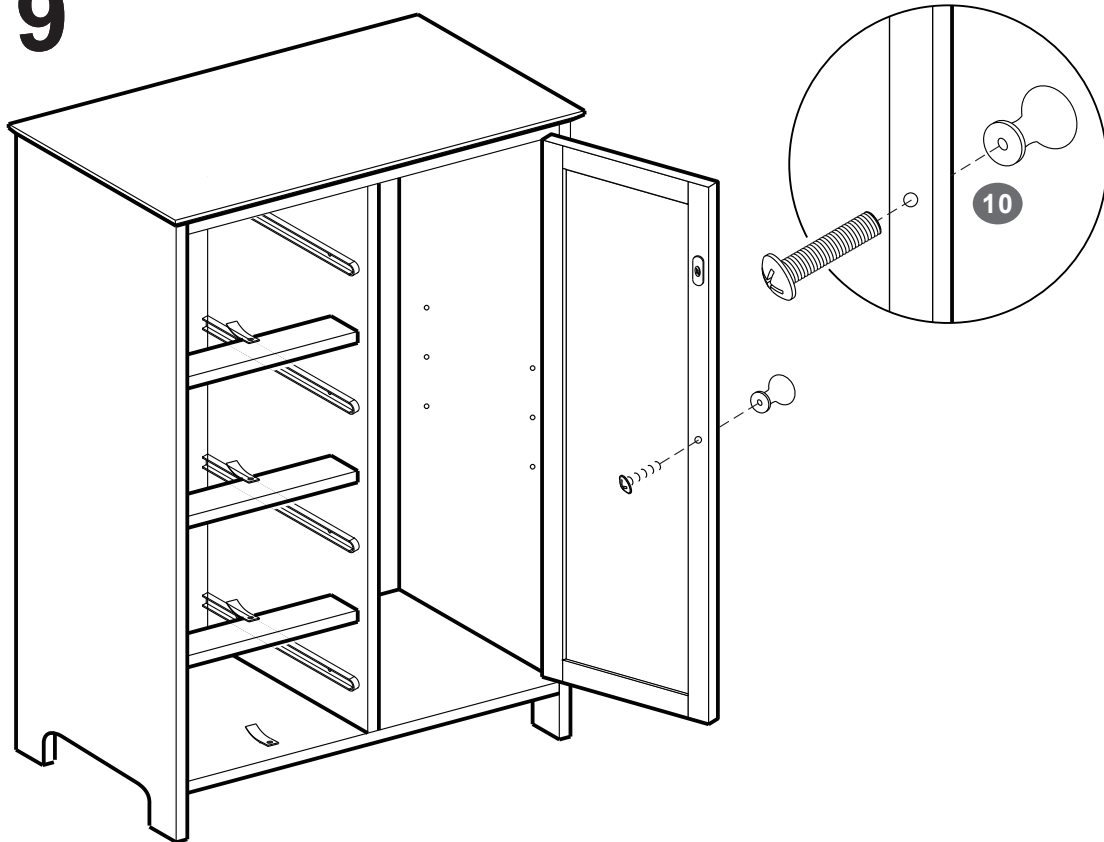

# STEP 20



# STEP 21

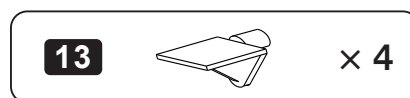
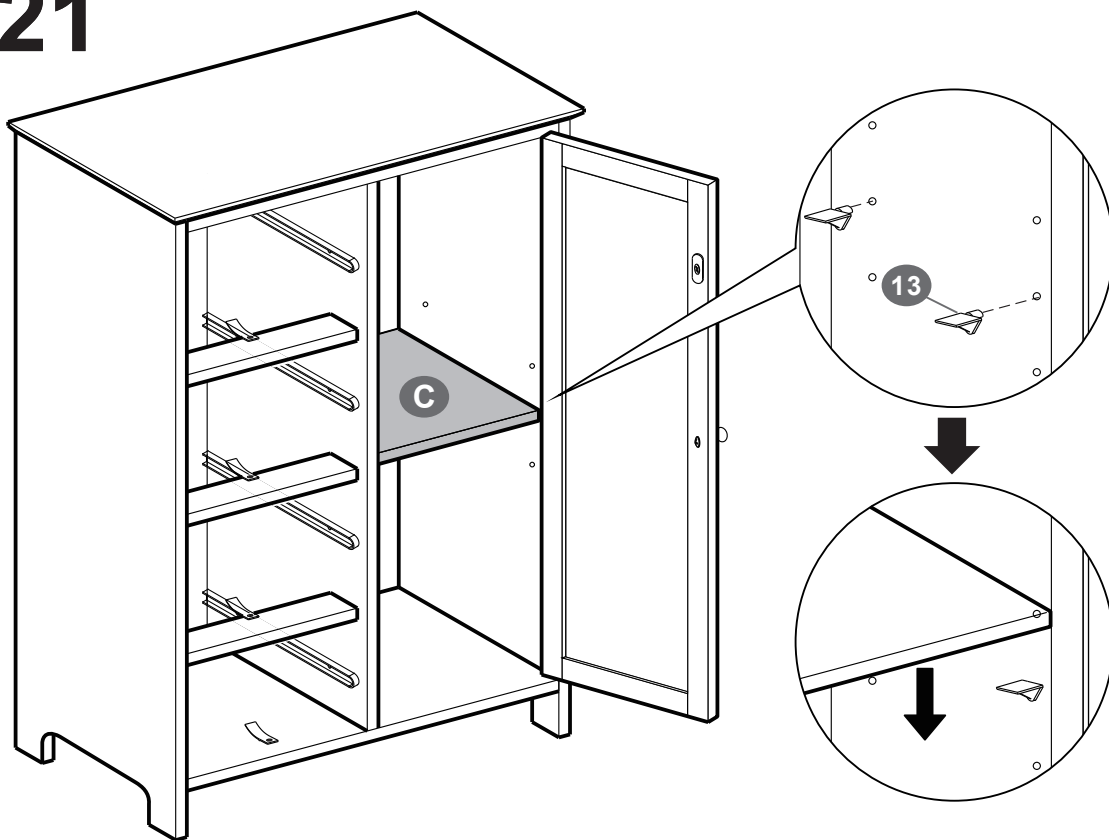

# STEP 22

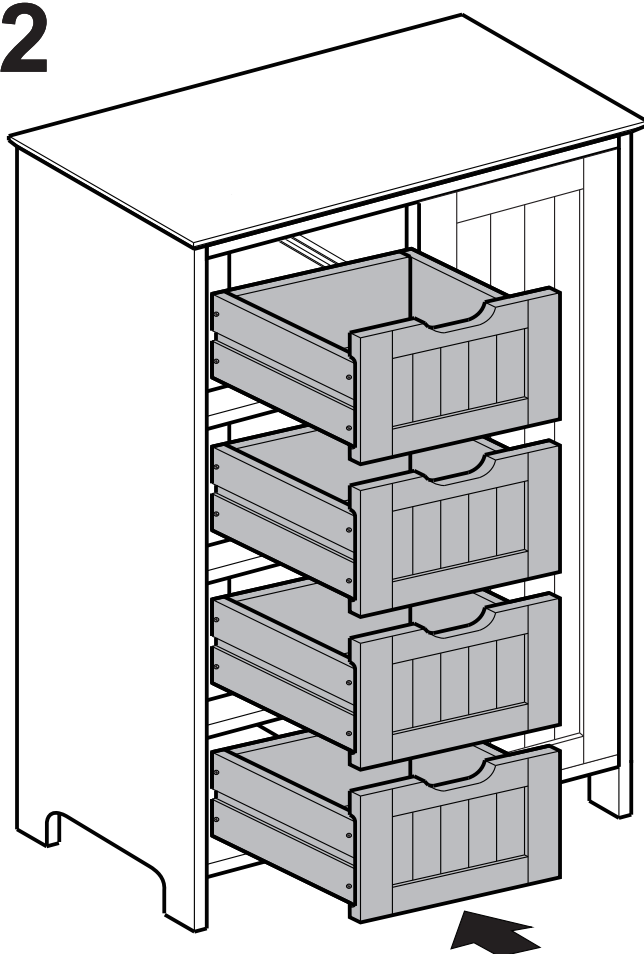

# STEP 23

Press here and take the drawer out

