

MAINTENANCE AND WARNING

- 1.Keep furniture away from heat sources.
- 2.Do not clean furniture with harsh cleaner or polishes.Do not use detergents,solvents,abrasives,spray packs or leather cleaner. Use non-color mild soa with warm water to clean spills(Mix 1:10 soap to water).
- 3.Do not place furniture under direct sunlight,material will possibly fade over time.
- 4.Do not use on site dry cleaning machine.Children should not climb or jump on the furniture.
- 5.Do not write on furniture that is not protectedby a padded barrier.
- 6.Not for commercial use,only for residential use.

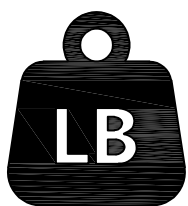

Weight Limitation

110 LBS

EXPLOSIVE VIEW

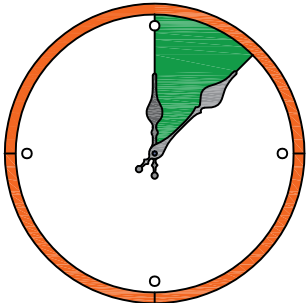
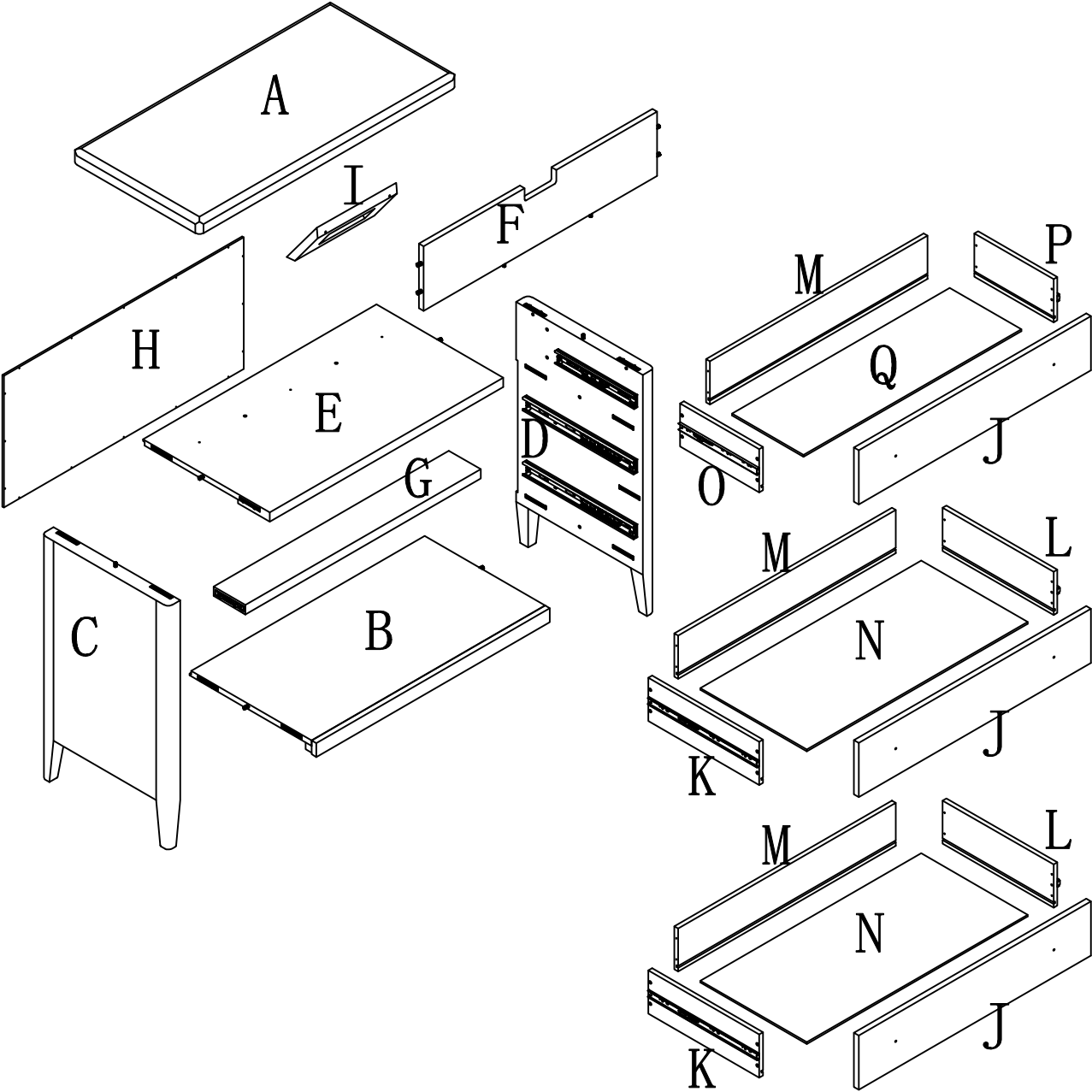

Around 65 min



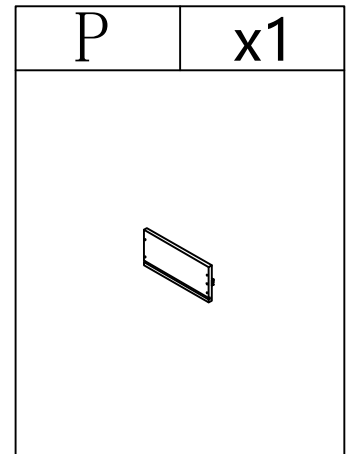
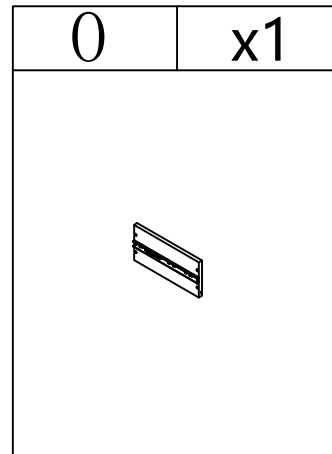
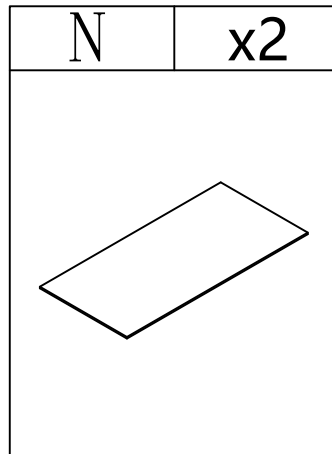
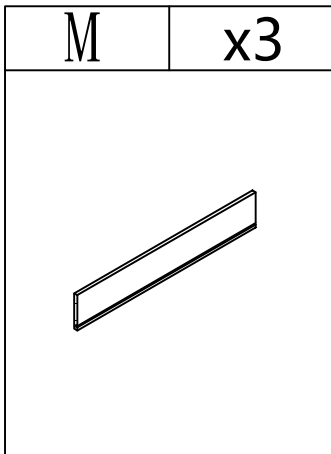
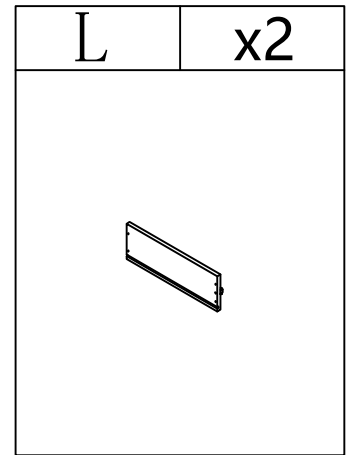
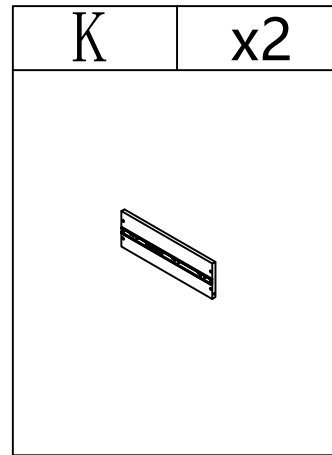
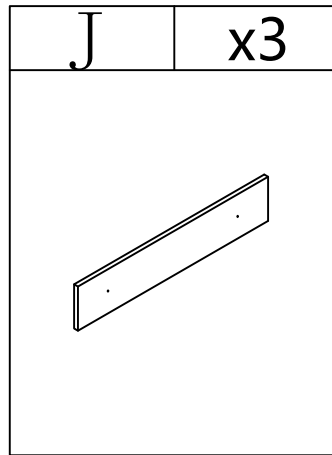
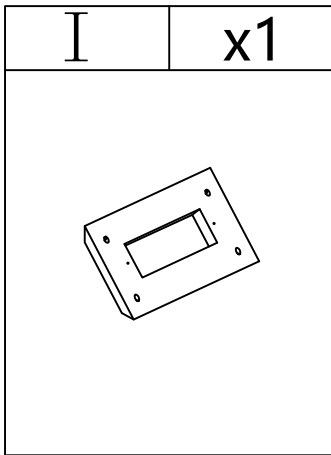
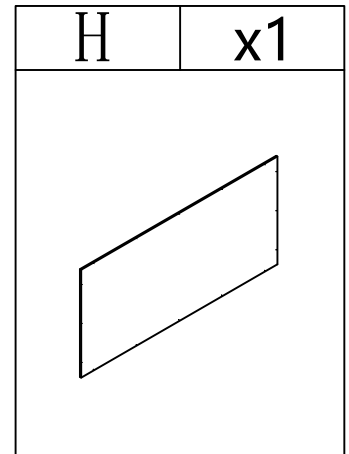
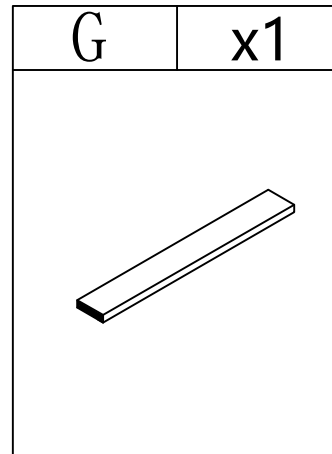
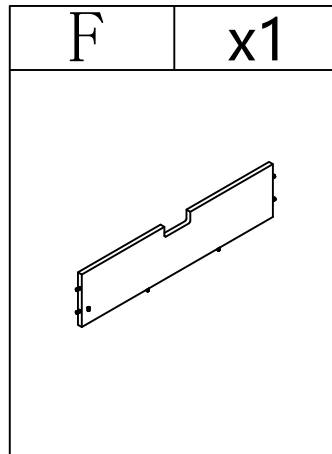
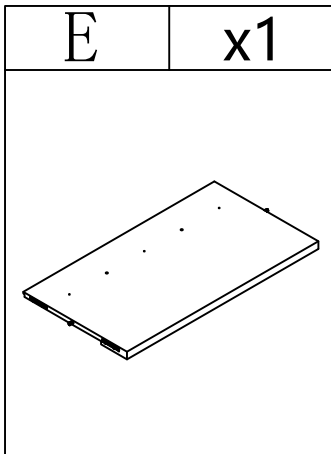
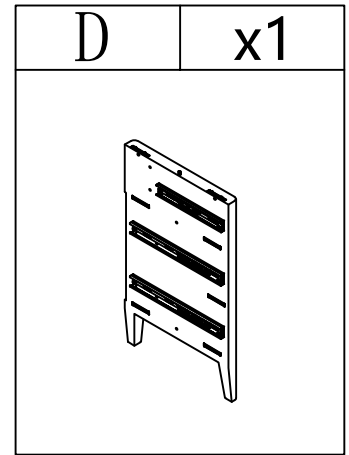
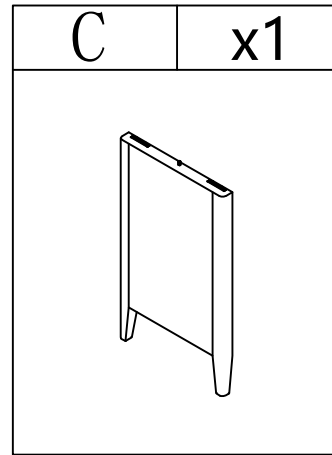
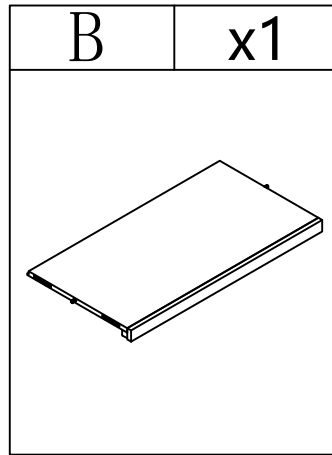
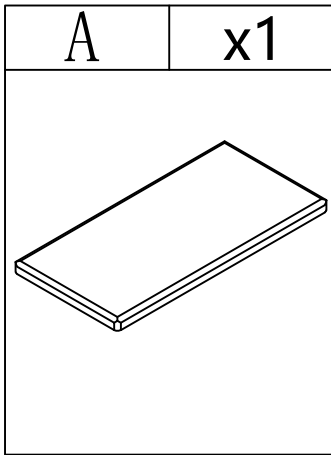

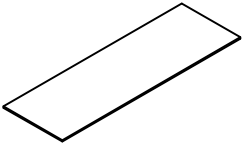

PARTS LIST

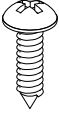
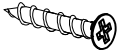
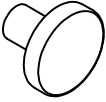

PARTS LIST

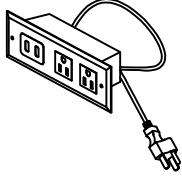
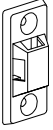
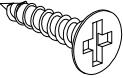
Q	x1
	

HARDWARE LIST

#1	x18	#2	x31	#3	x6	#4	x6	#5	x1	#6	x4
											
φ3*14mm		φ8#*1"				φ5/32#*1"					
#7	x4	#8	x4	#9	x4	#10	x2				
											
φ3*16mm*6#		φ3.5*35mm*7#									

TOOL LIST

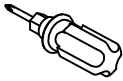
#11	x1	#12	x1
			
M4			

HARDWARE SPARE LIST

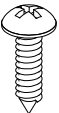
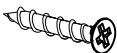
#1	x2	#2	x3
			
φ3*14mm		φ8#*1"	

ASSEMBLY INSTRUCTIONS

STEP-1

1. Insert part (F) into part (E), make sure all holes align. connect part (F) to part (E) with screw #2, tight it with screwdriver #12.

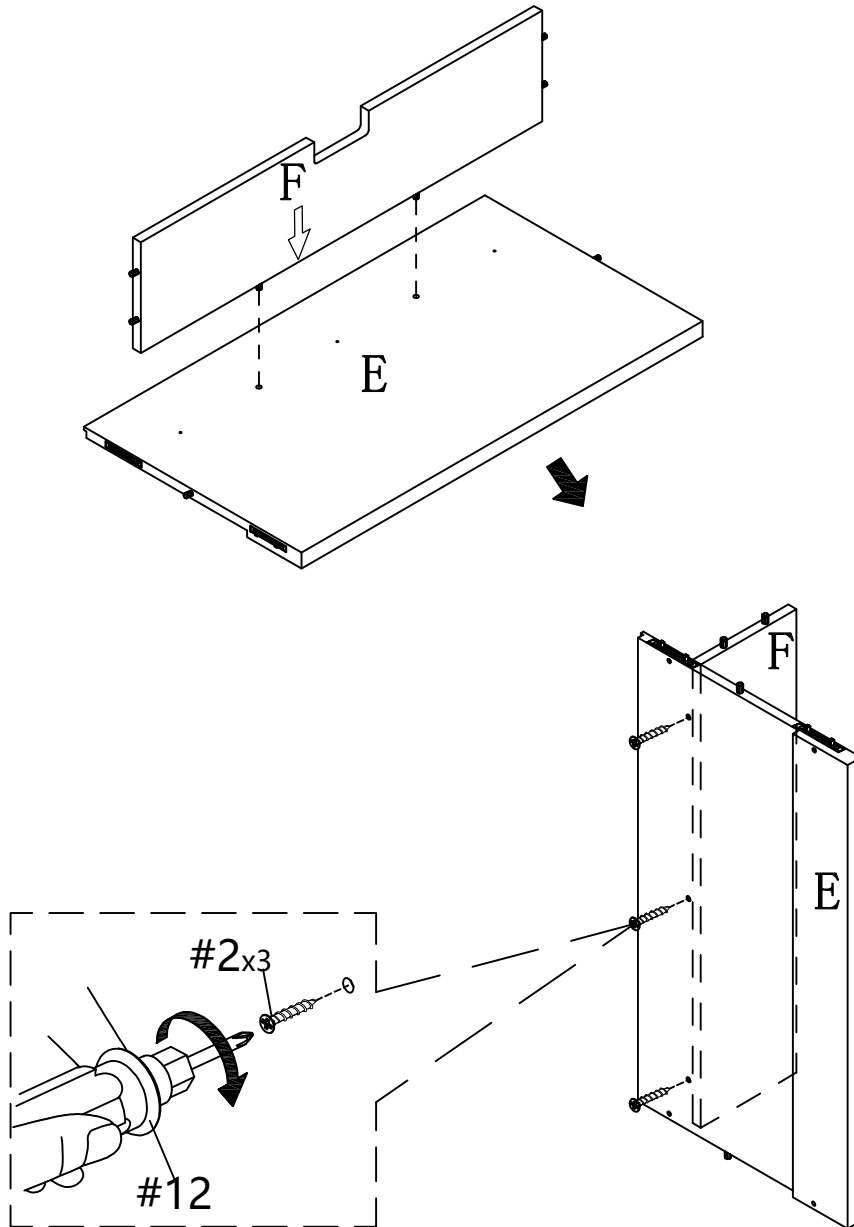

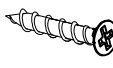
#2	x3
	
ø8#*1"	

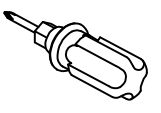
#12	x1
	

ASSEMBLY INSTRUCTIONS

STEP-2

1. Insert part (E/F) into part (C), make sure all holes align. Tighten it with allen key #11.

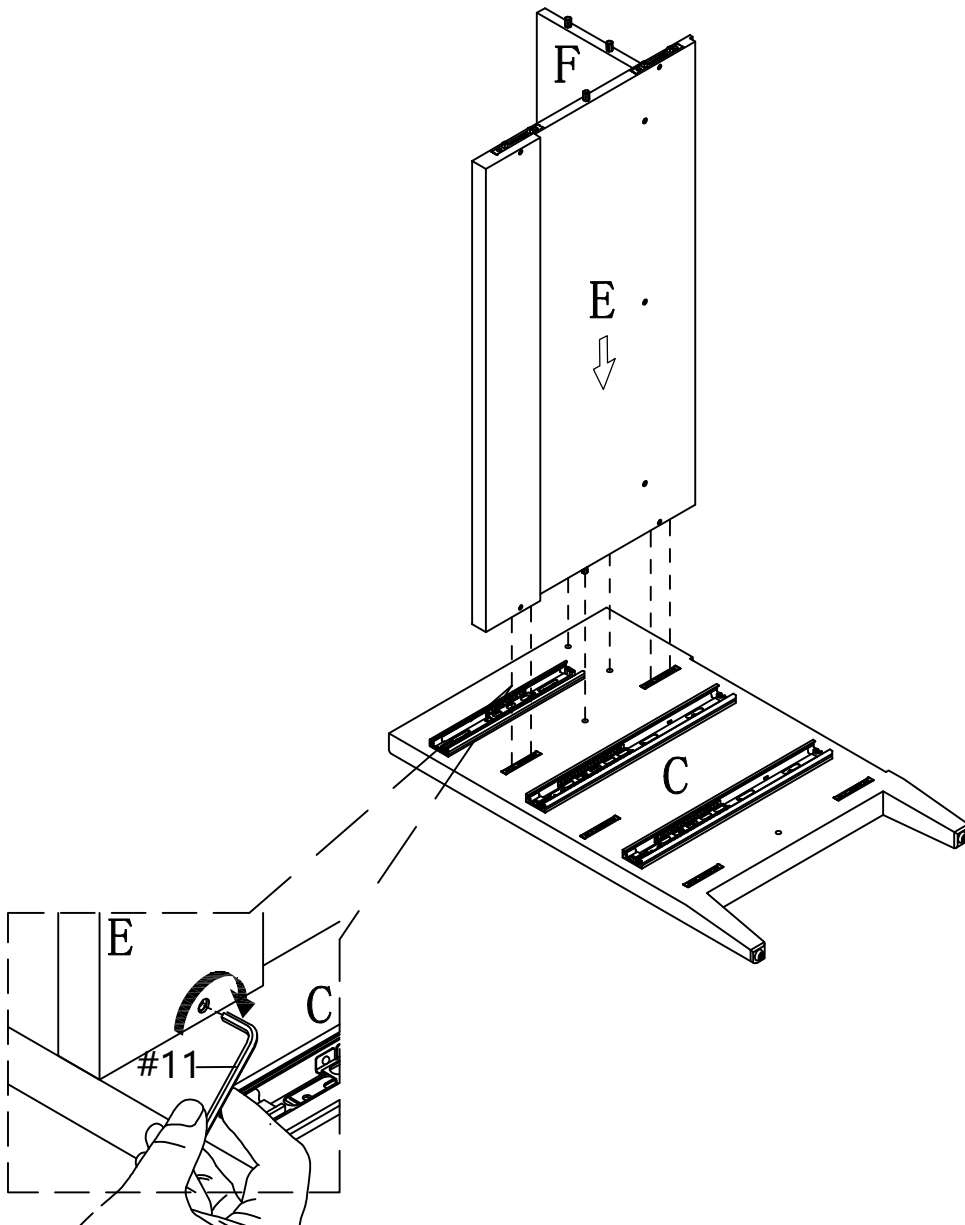

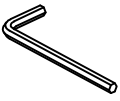
#11	x1
	
M4	

ASSEMBLY INSTRUCTIONS

STEP-3

1. Insert part (G) into part (C), make sure all holes align. Tighten it with allen key #11.

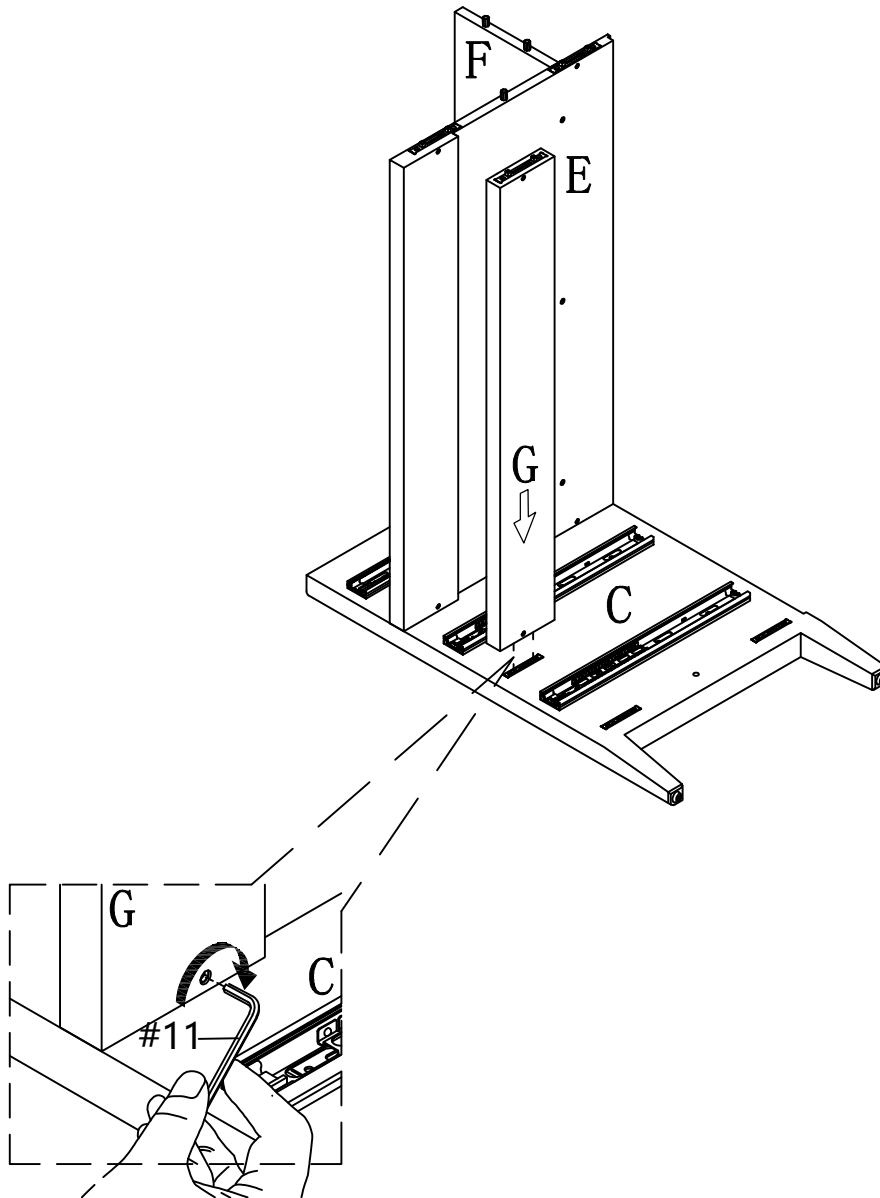

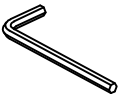
#11	x1
	
M4	

ASSEMBLY INSTRUCTIONS

STEP-4

1. Insert part (B) into part (C), make sure all holes align. Tighten it with allen key #11.

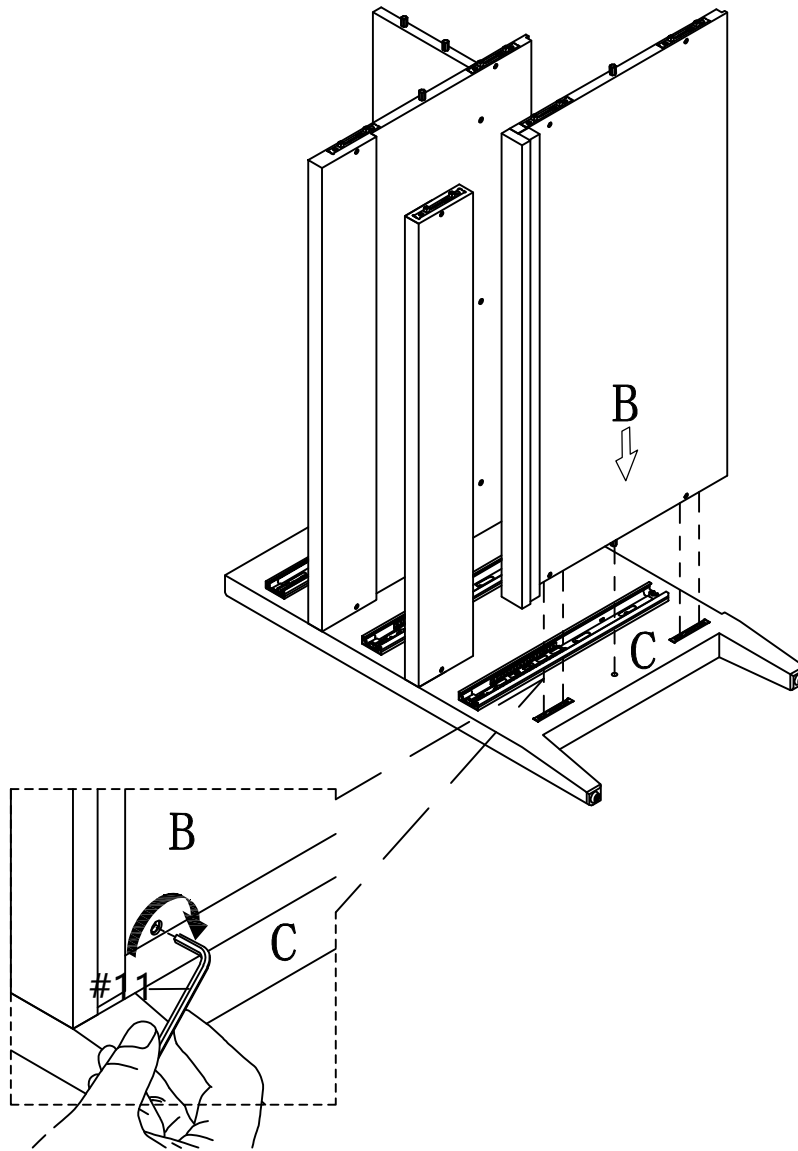

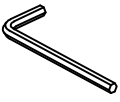
#11	x1
	
M4	

10/26

ASSEMBLY INSTRUCTIONS

STEP-5

1. Insert part (D) into the unit pre-assembled at step 4, make sure all holes align. Tight it with allen key #11.

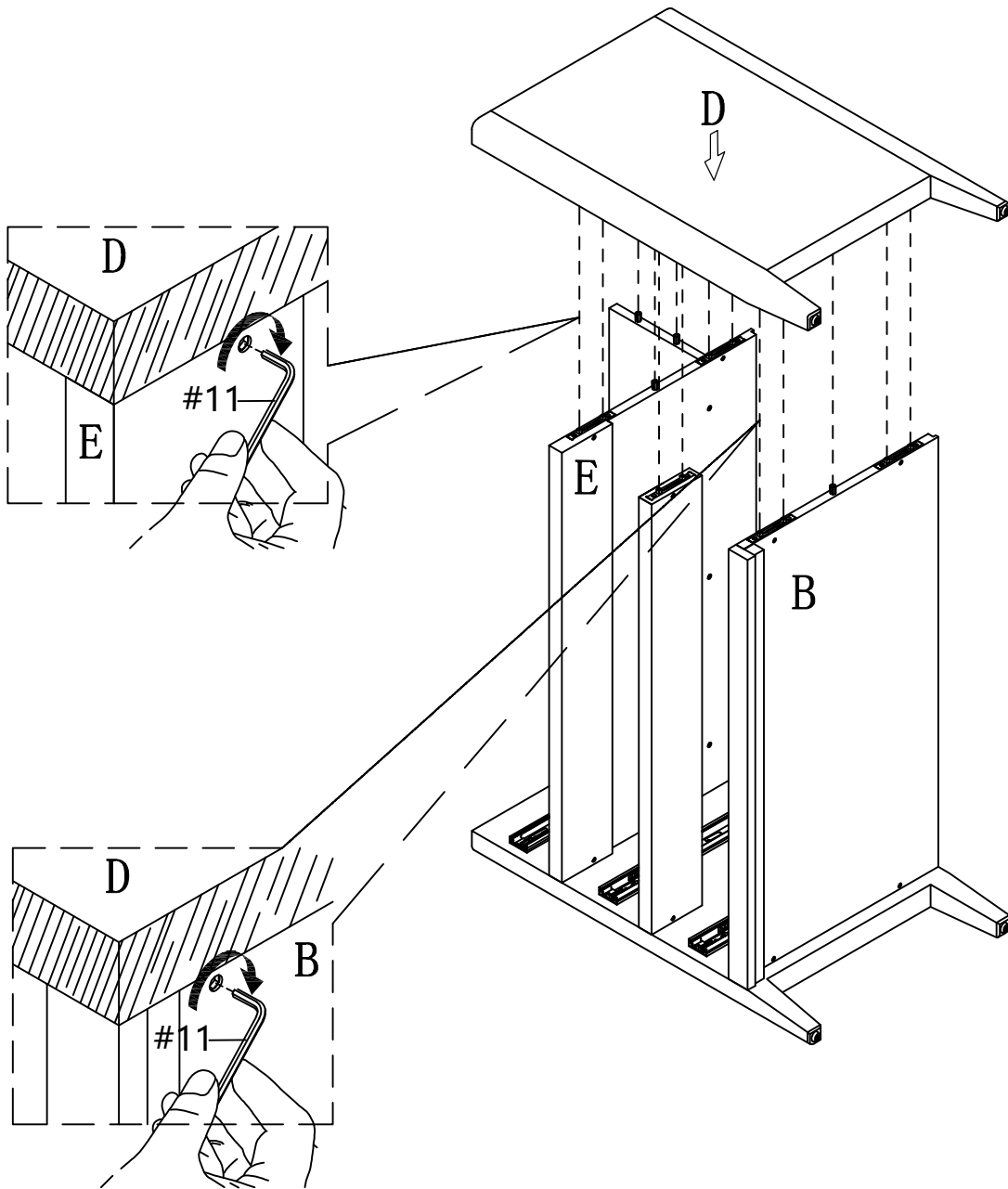

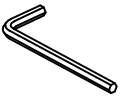
#11	x1
	
M4	

ASSEMBLY INSTRUCTIONS

STEP-6

1. Insert part (A) into the unit pre-assembled at step 5, make sure all holes align. Tighten it with allen key #11.

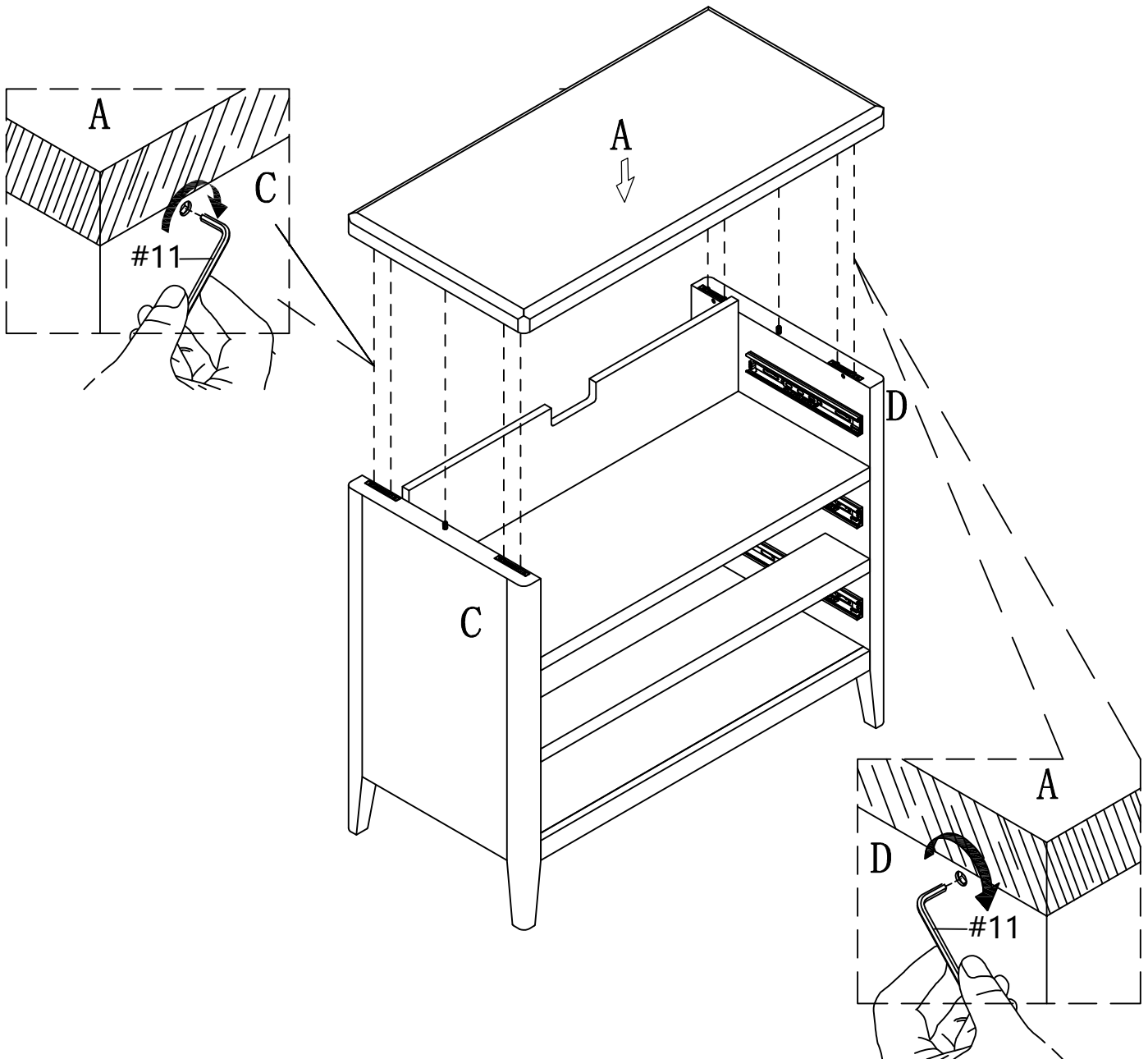

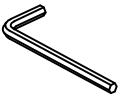
#11	x1
	
M4	

ASSEMBLY INSTRUCTIONS

STEP-7

1. connect part (H) to the unit pre-assembled at step 6 with bolt #1, tight bolt with screwdriver #12.

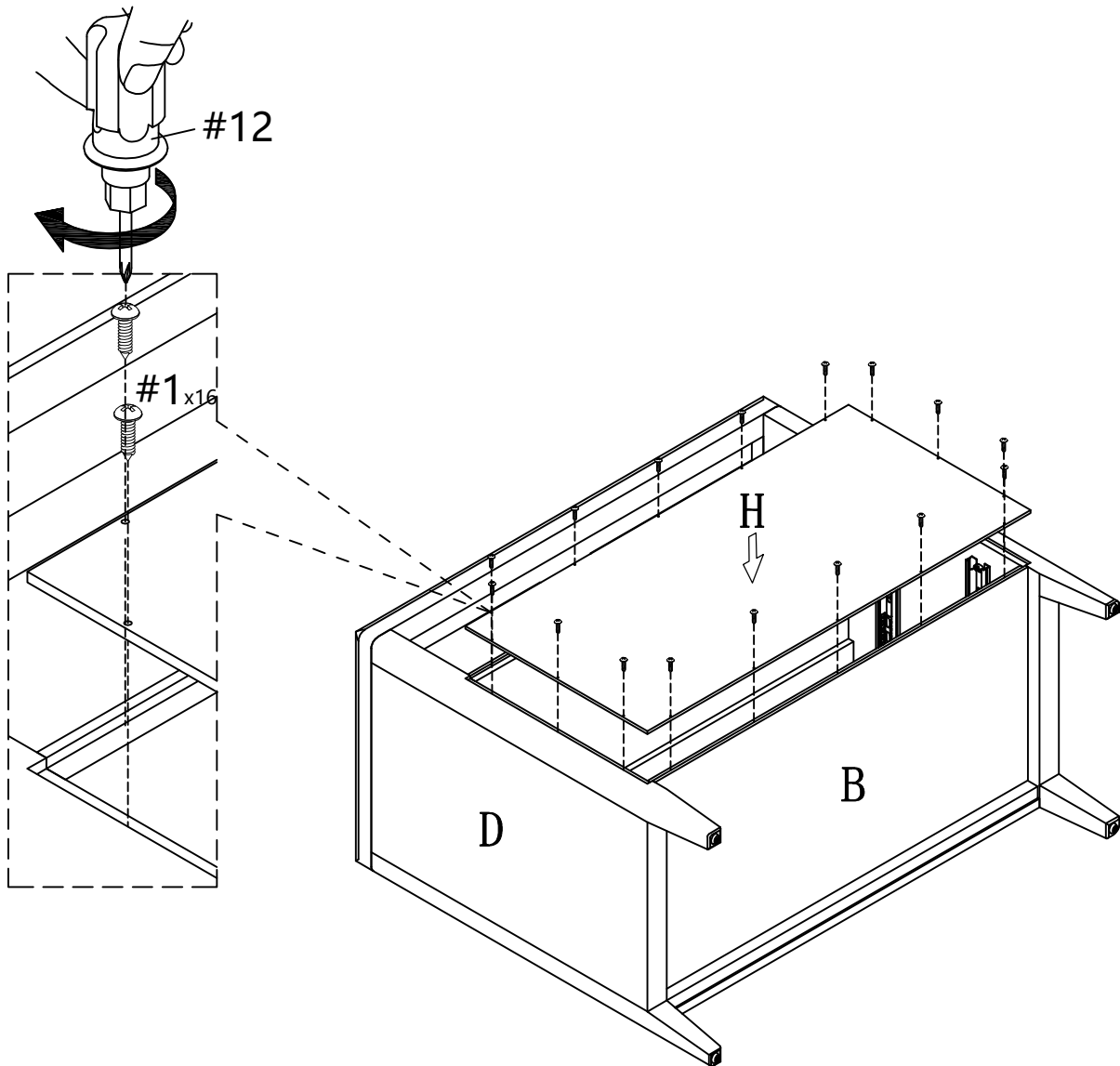

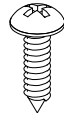
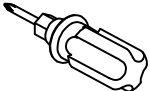
#1	x16	#12	x1
			
ø3*14mm			

ASSEMBLY INSTRUCTIONS

STEP-8

1. connect part #6 to the unit pre-assembled at step 7 with screw #7, tight bolt with screwdriver #12.

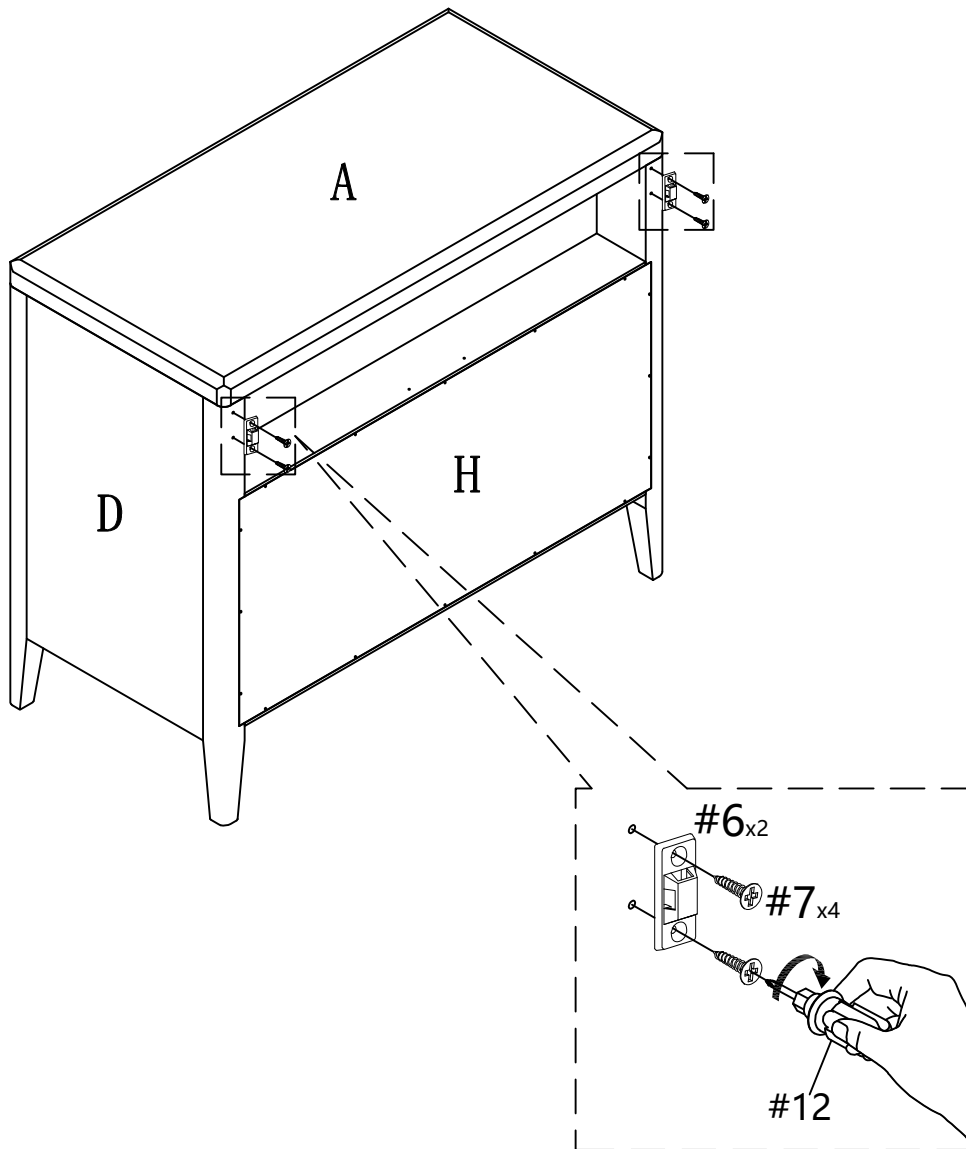

#6	x2	#7	x4	#12	x1
		ø3*16mm*6#			

ASSEMBLY INSTRUCTIONS

STEP-9

1. connect part #5 to part (I) with screw #1, tight screw with screwdriver #12.

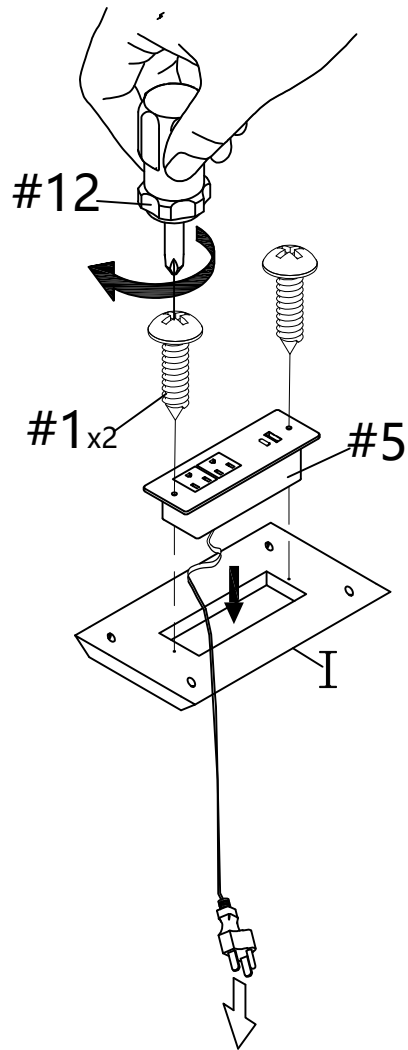

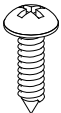
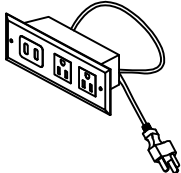
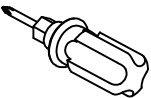
#1	x2	#5	x1	#12	x1
					
ø3*14mm					

ASSEMBLY INSTRUCTIONS

STEP-10

1. connect part (I) to the unit pre-assembled at step 9 with screw #2, tight screw with screwdriver #12.

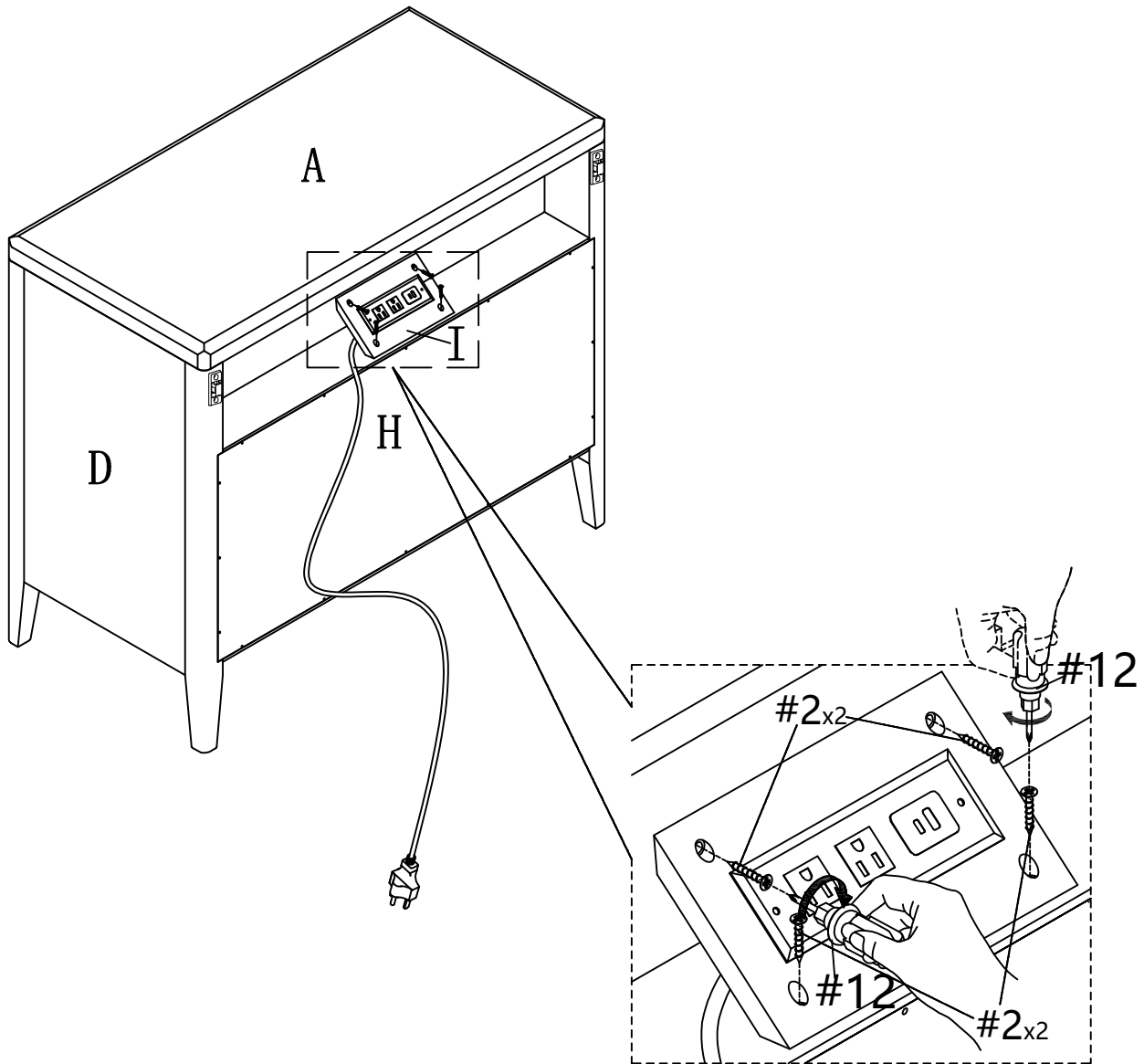

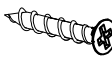
#2	x4
	
ø8#*1"	

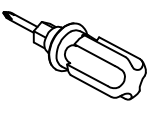
#12	x1
	

ASSEMBLY INSTRUCTIONS

STEP-11

1. connect part (O/P) to part (J) with screw #2, tight screw with screwdriver #12. slide part (Q) to part (O/P), make sure it also in the groove of part (J).

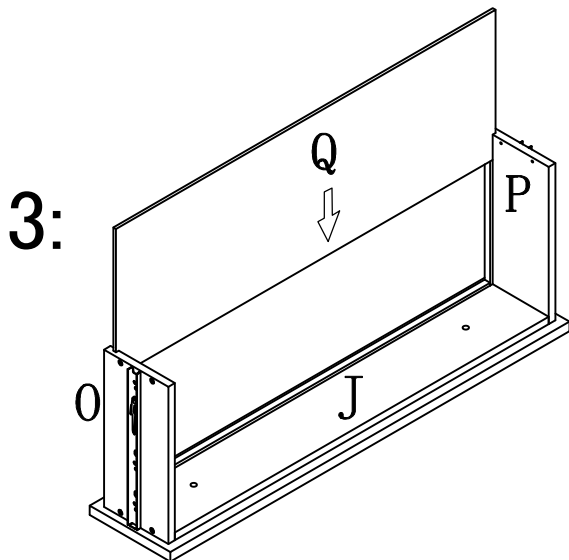
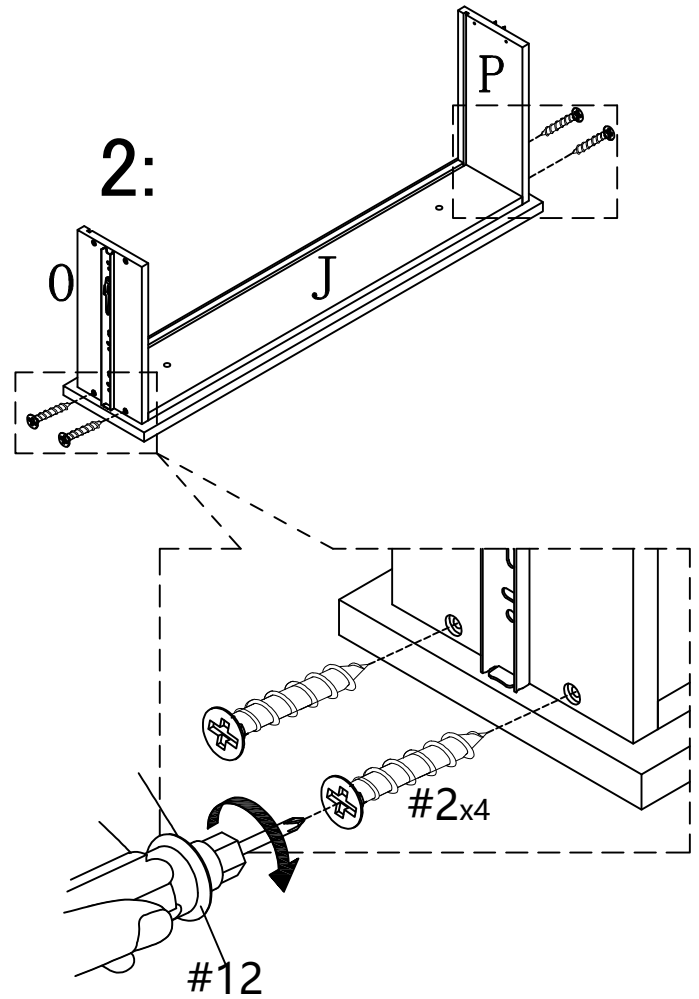
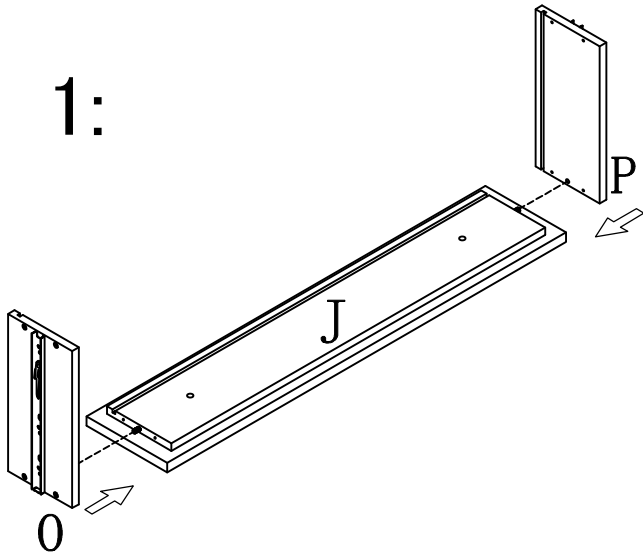

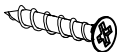
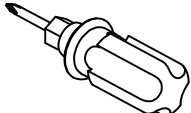

#2	x4	#12	x1
			
φ8#*1"			

ASSEMBLY INSTRUCTIONS

STEP-12

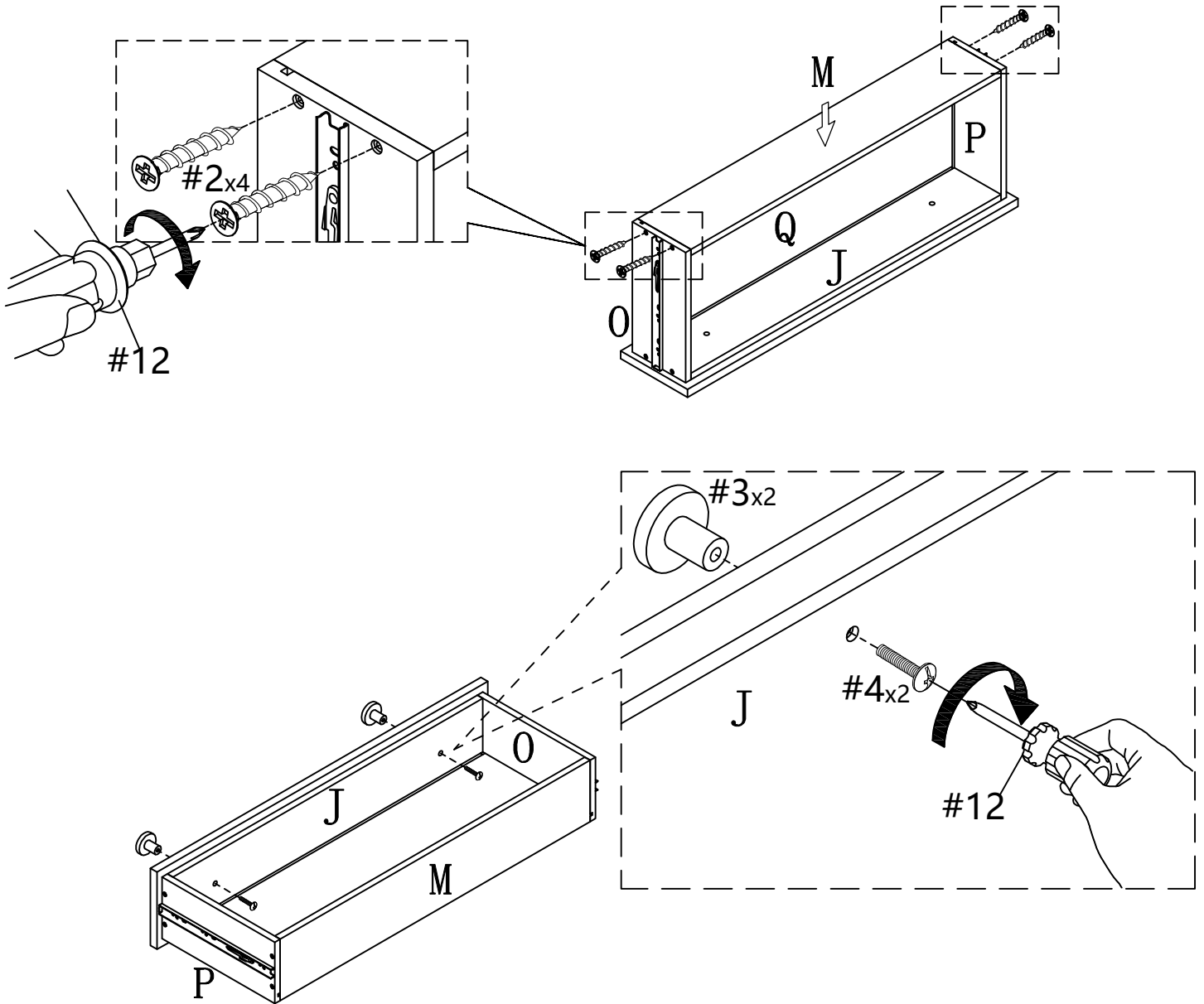
1. connect part (O/P) to part (M) with screw #2, tight screw with screwdriver #12. connect part #3 to part (J) with small bolt #4, tight bolt with screwdriver #12.

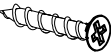
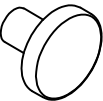

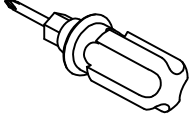
#2	x4	#3	x2	#4	x2	#12	x1
							
φ8#*1"				φ5/32#*1"			

ASSEMBLY INSTRUCTIONS

STEP-13

1. connect the top drawer (J) to the body with hand.

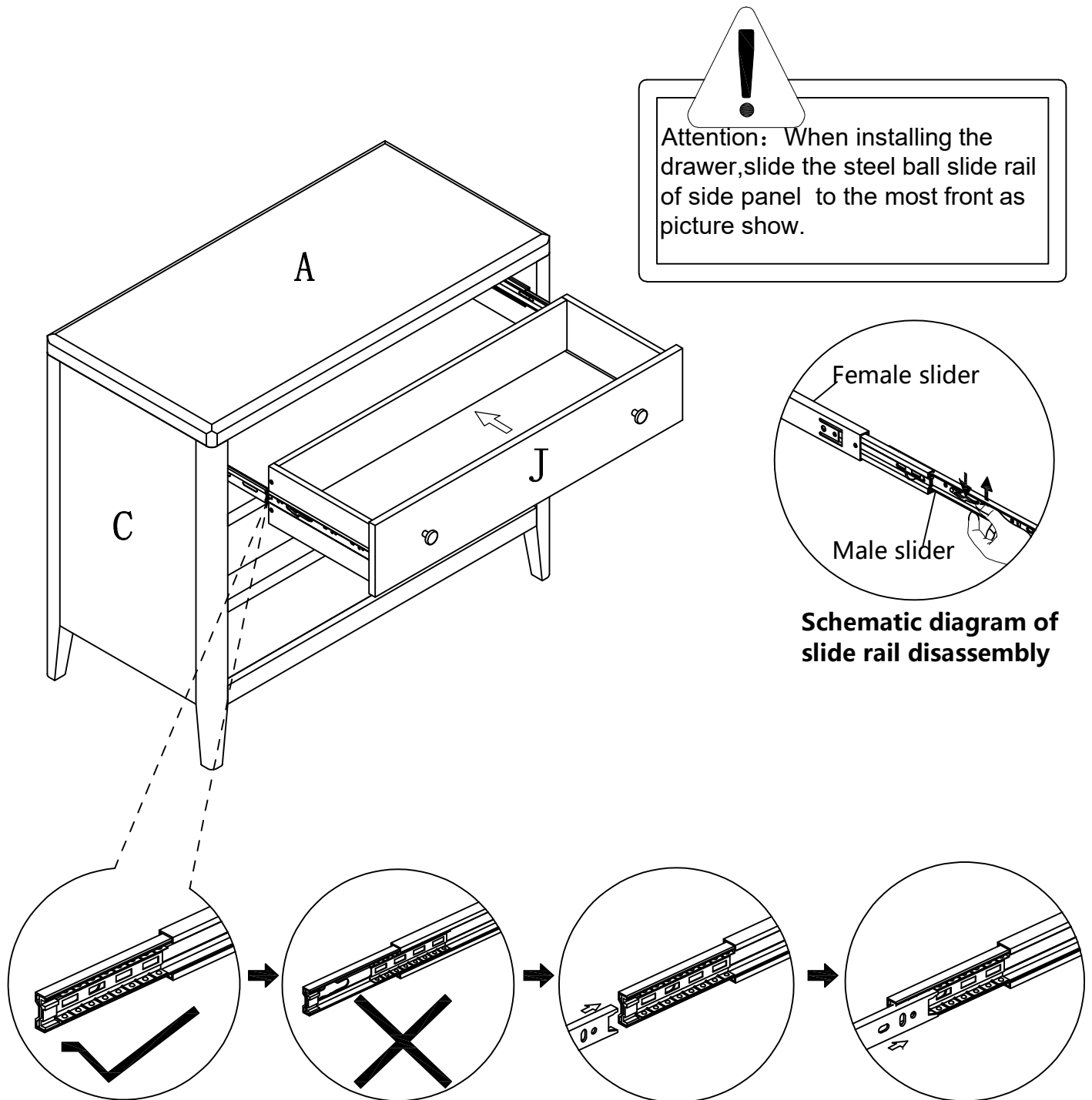

ASSEMBLY INSTRUCTIONS

STEP-14

1. connect part (K/L) to part (J) with screw #2, tight screw with screwdriver #12. slide part (N) to part (K/L), make sure it also in the groove of part (J).

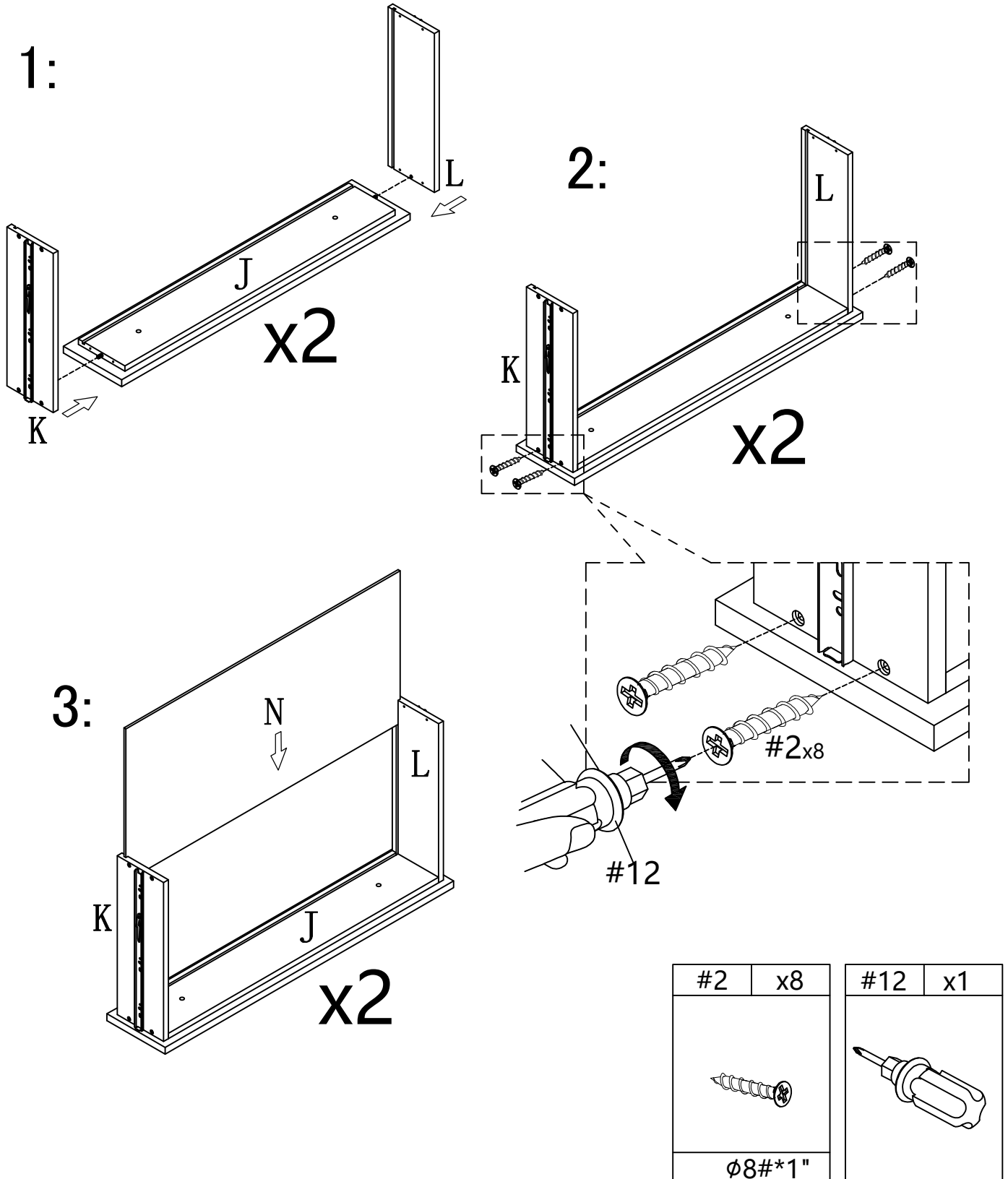



ASSEMBLY INSTRUCTIONS

STEP-15

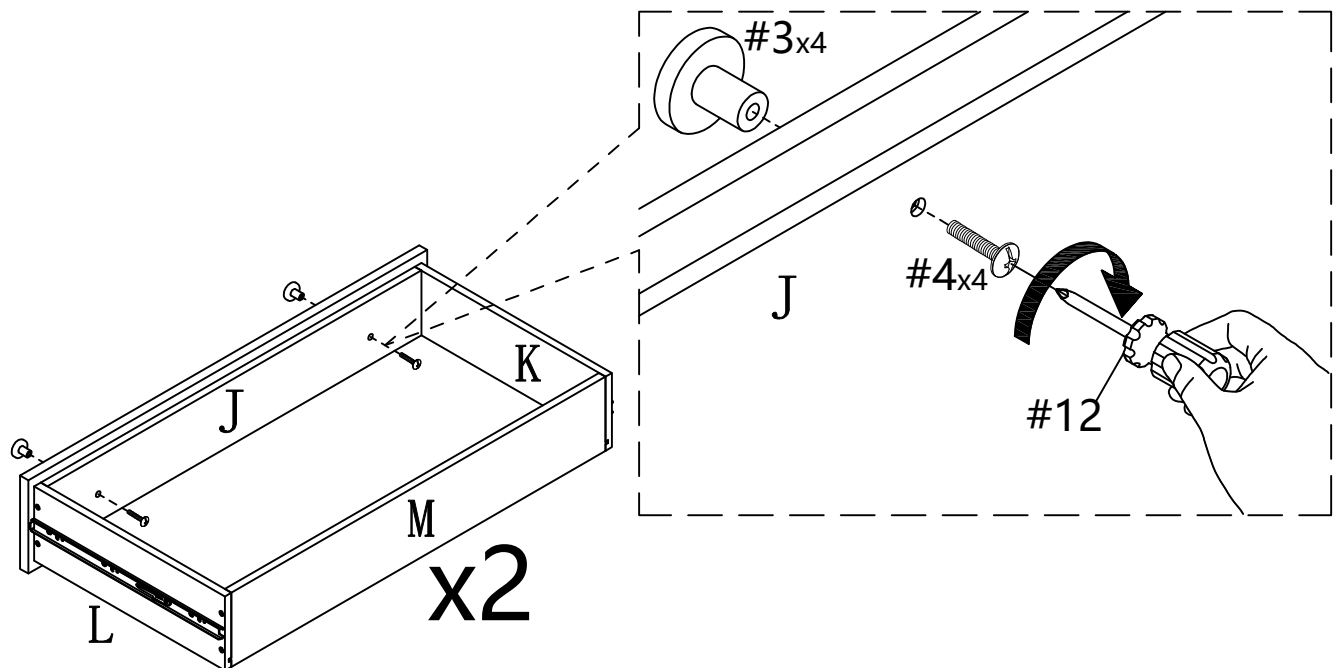
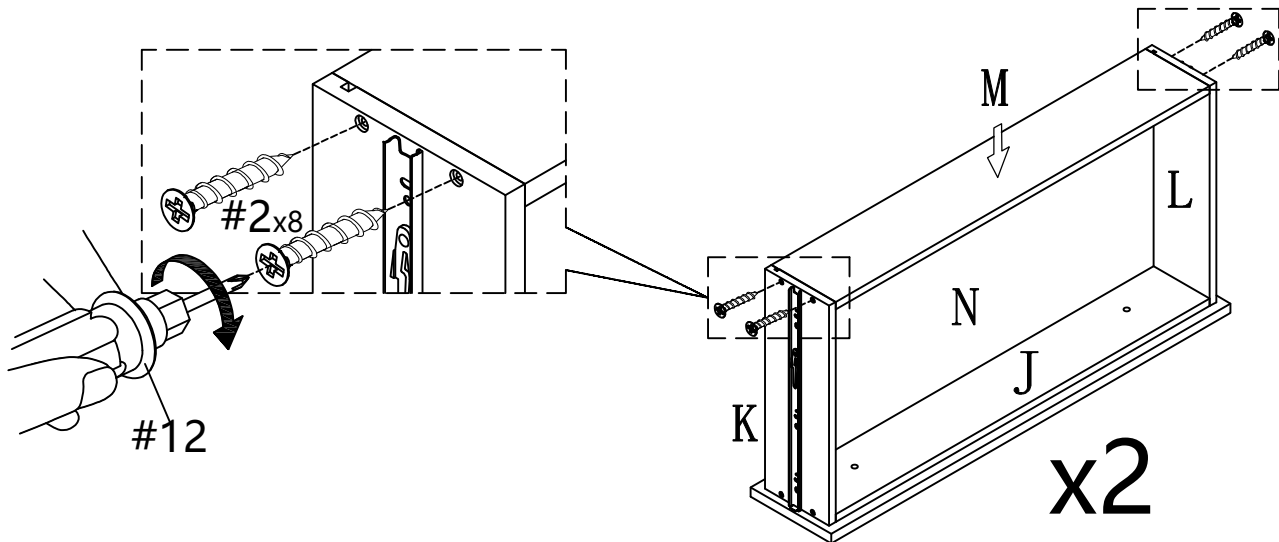
1. connect part (K/L) to part (M) with screw #2, tight screw with screwdriver #12. connect part #3 to part (J) with small bolt #4, tight bolt with screwdriver #12.

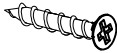
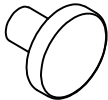

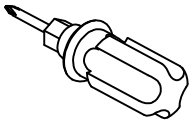
#2	x8	#3	x4	#4	x4	#12	x1
							
φ8#*1"				φ5/32#*1"			

ASSEMBLY INSTRUCTIONS

STEP-16

1. connect the two bottom drawer (J) to the body with hand.

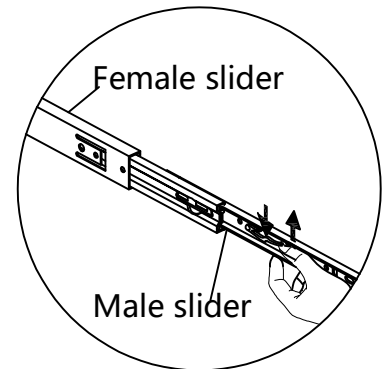
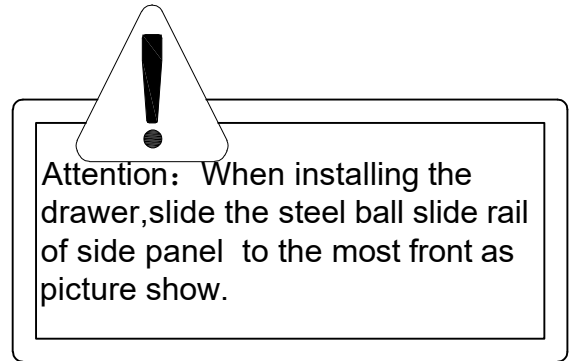
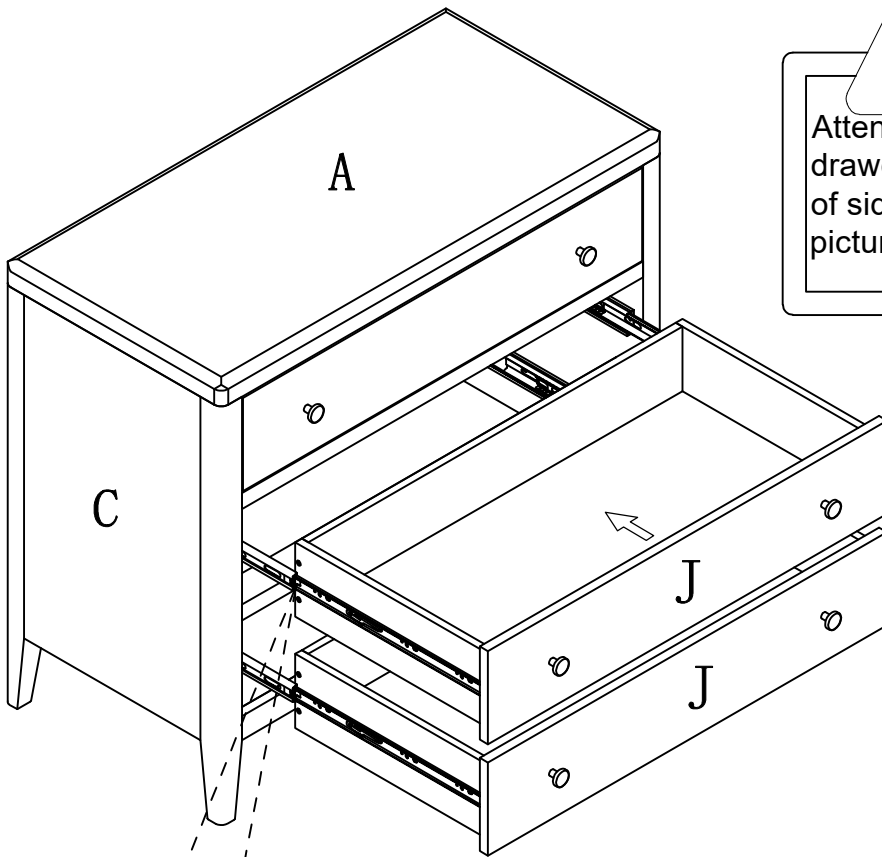

Schematic diagram of slide rail disassembly

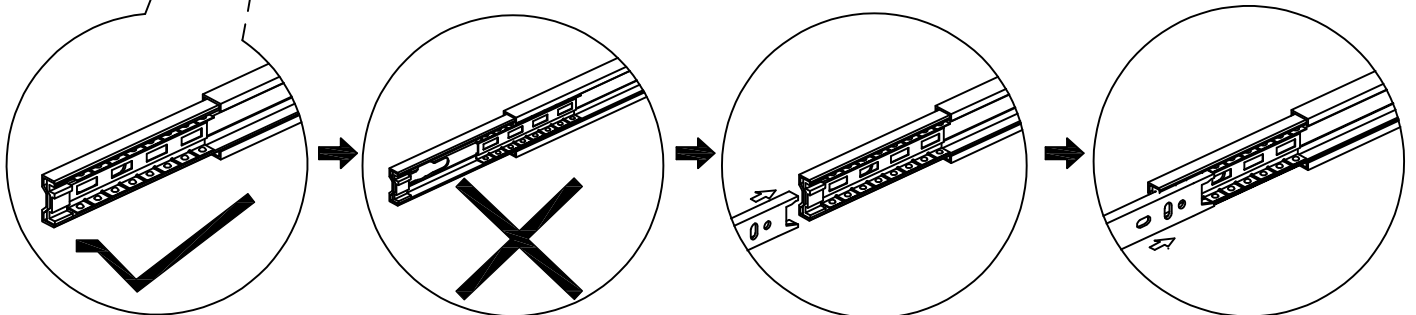

ASSEMBLY INSTRUCTIONS

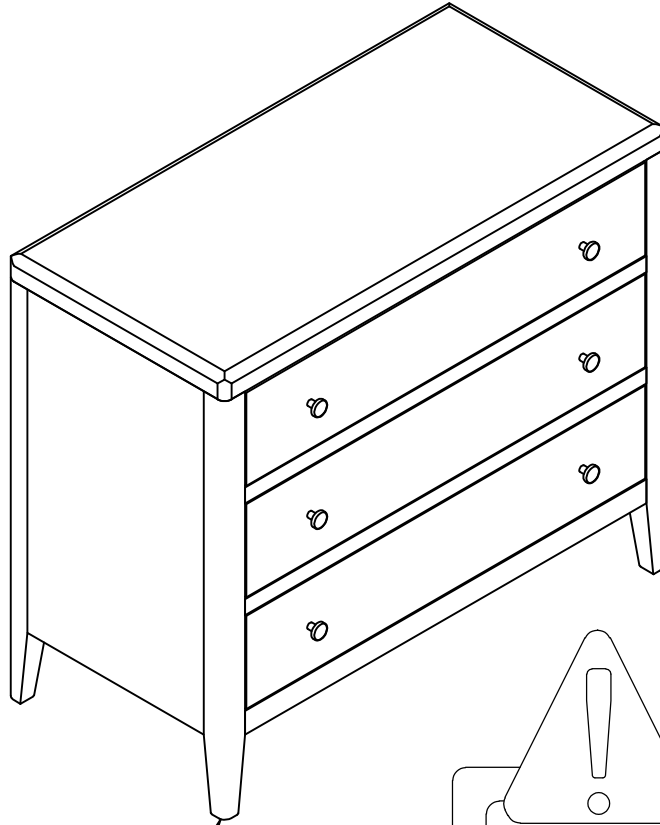

STEP-17

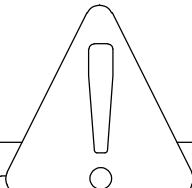

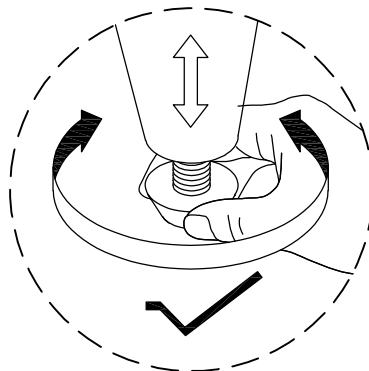
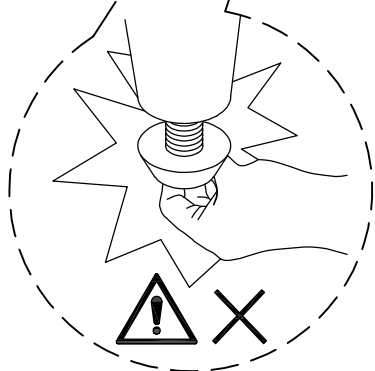
Attention:
Before the next step, adjust the feet of the locker to keep it level.

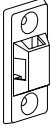

ASSEMBLY INSTRUCTIONS

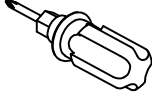
#6	x2	#8	x4	#9	x4	#12	x1
							
		Ø3.5*35mm*7#					

STEP-18

1. Install the anti-collapse device.
2. Mark the position on the wall, that corresponds to the location of part (#6) on the back of the body; Drill and insert the expandable screw (#9) by hammer.
3. Assemble the part (#6) to the well. Align the hole in the part (#6) with the expandable screw (#9), use screw (#8) to attach it and tighten by screwdriver (#12)

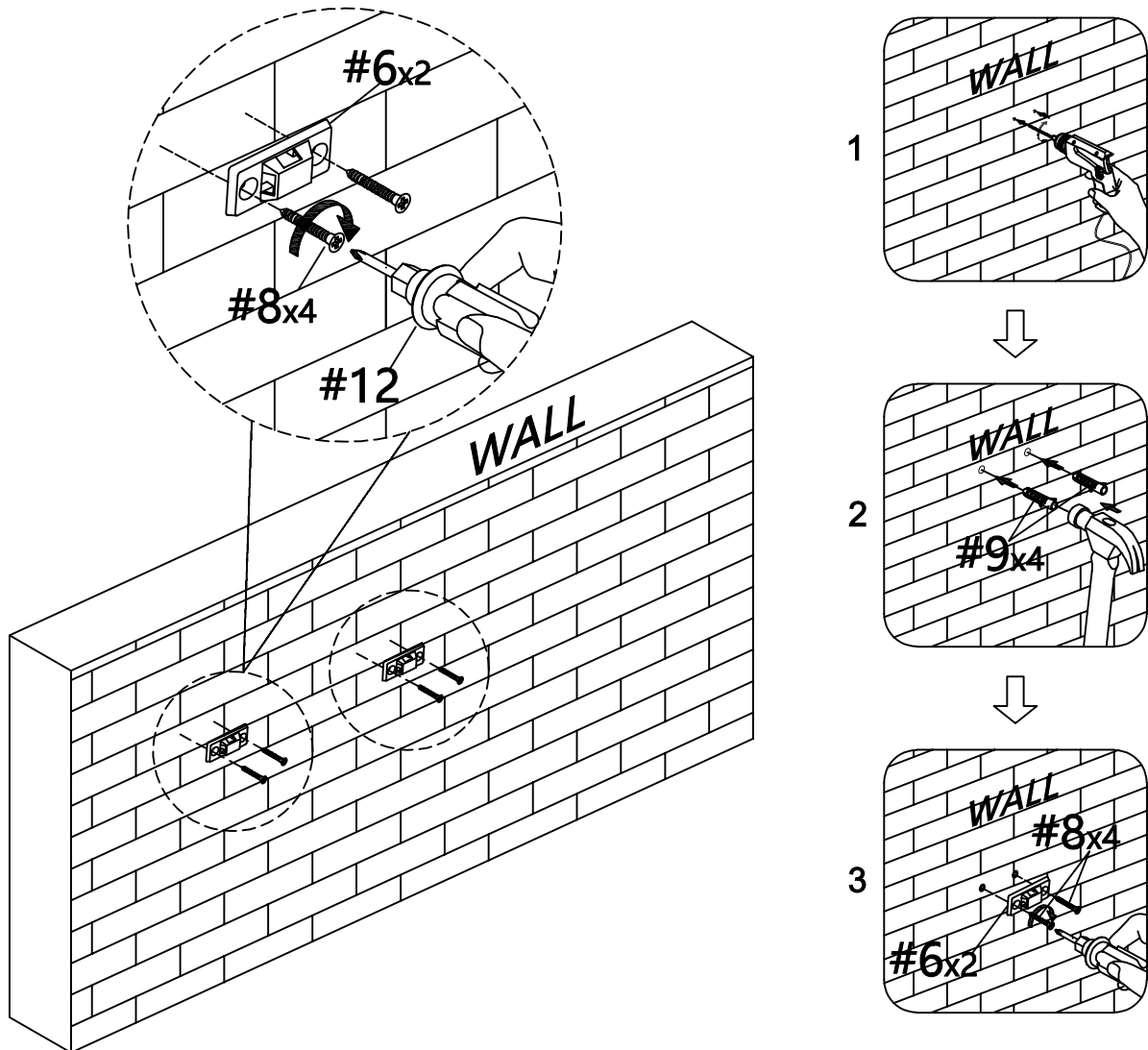

ASSEMBLY INSTRUCTIONS

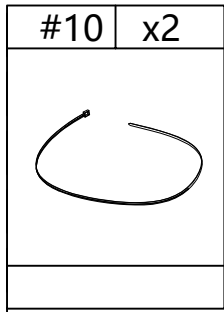

STEP-19

1. Let the plastic belt (#10) pass through the both part (#6) and pull tightly.

STEP-19

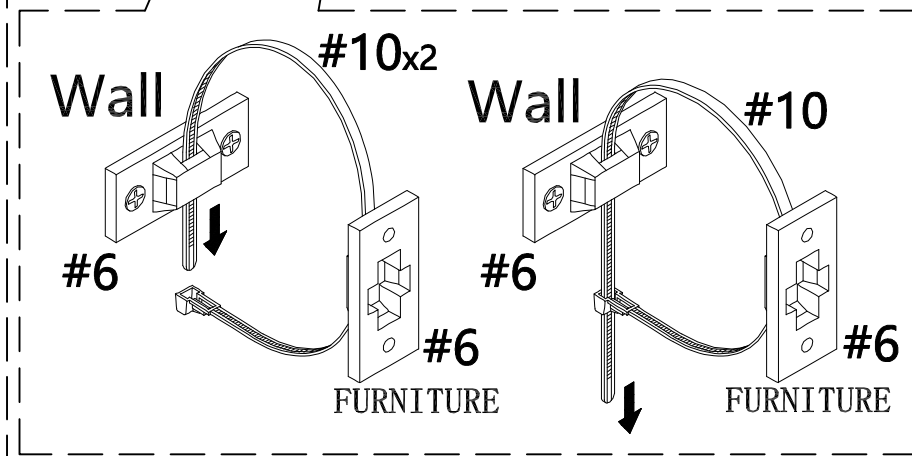
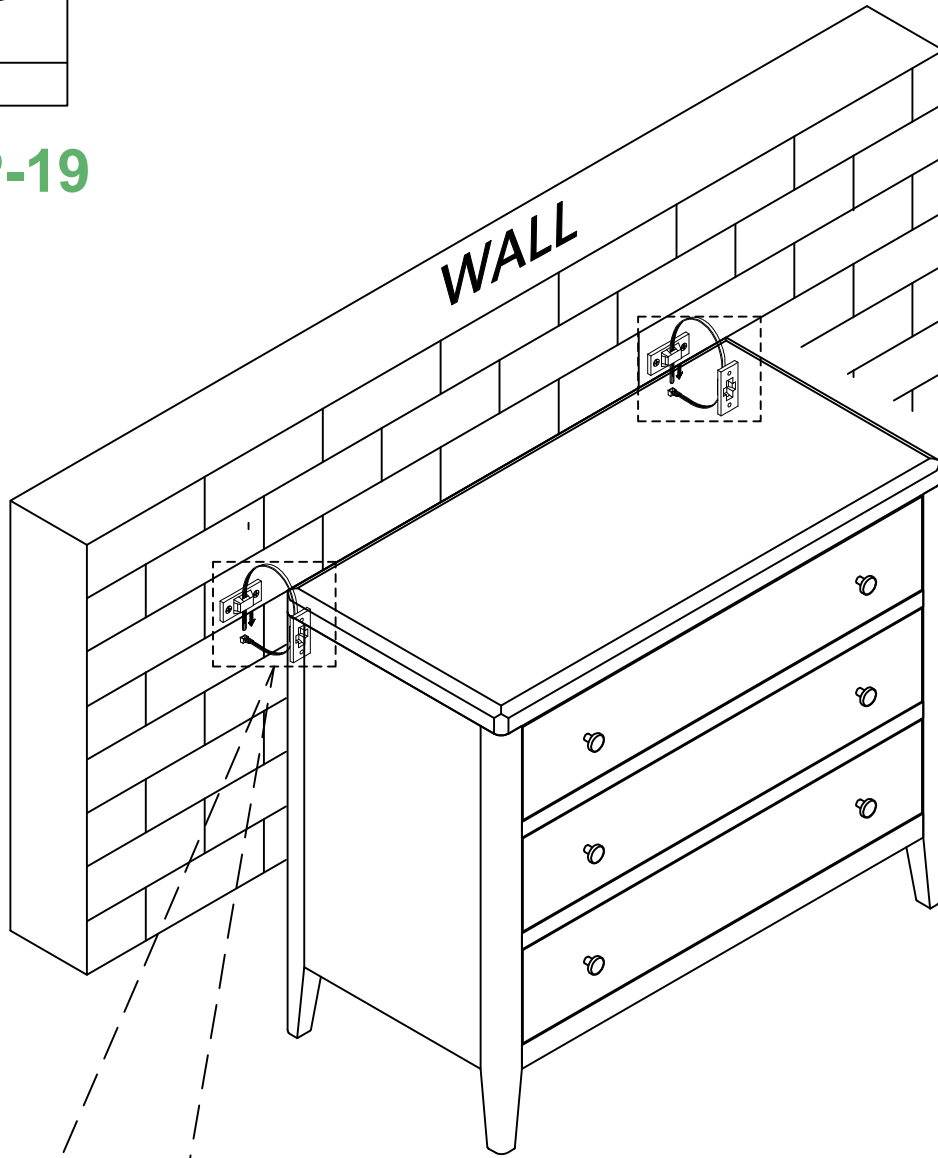

WARRANTY

1. We strive to offer high-quality products, and we also try our best to satisfy each and every customer that orders from us with product or service as needed.
2. We provide 30 days warranty starting from the time you receive the item. Each customer must provide a record of their order such as the order number, or item receipt for any items that are out of the warranty period you may also still receive.
3. Replacement parts by purchasing them with our company if they are available.