

S02

Installation Instructions

Sliding Shower and Bath Doors

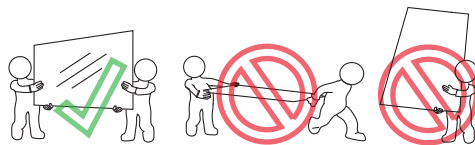
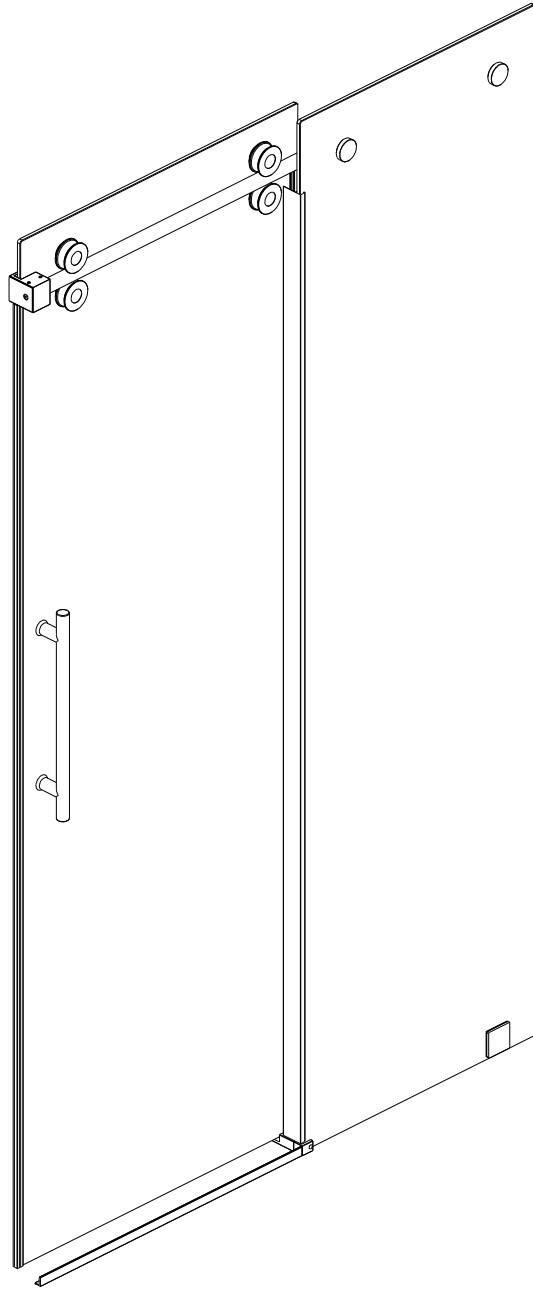

This door requires professional installation. Two installers recommended.

All the plastic bag is not a toy, keep it out of reach of infants and children to avoid choking hazards.

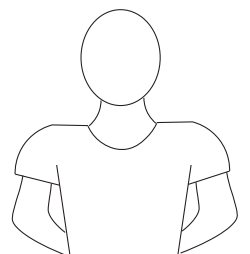

**Professional
Installation required**

V01-2025-09

Tools



Level

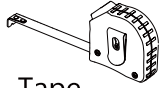

Tape Measure

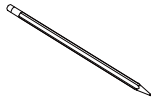

Pencil

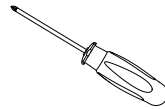

Phillips Screwdriver

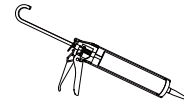

Silicone

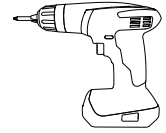

Power Drill



Drill Bit
Ø1/8"
(3mm)



Drill Bit
Ø3/16"
(4mm)



Drill Bit
Ø1/4"
(6mm)



Drill Bit
Ø5/16"
(8mm)



Drill Bit
Ø3/8"
(10mm)



Soft Head Hammer

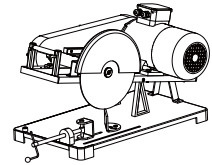

Chop saw**



Safety Glasses



Work Gloves

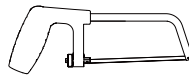

Hacksaw**

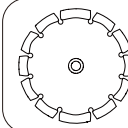

**Use the proper saw blade to cut stainless steel.



Painter's Tape



Razor Knife



Extender Driver Bit



#3 Phillips Driver Bit

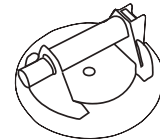

Professional-grade Glass suction cup



Measure the finished opening before proceeding with the installation to be sure that the correct model size has been ordered.

Be sure to cover the shower drain to prevent losing small parts.



Threshold must be level; Walls must be plumb.

Detailed Diagram of Shower Door Components

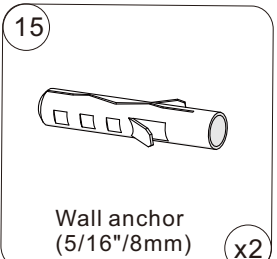
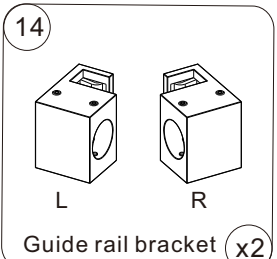
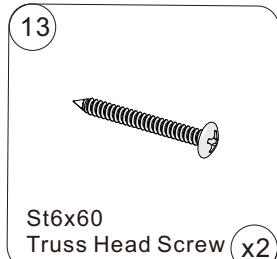
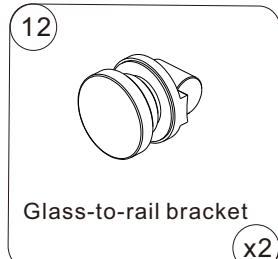
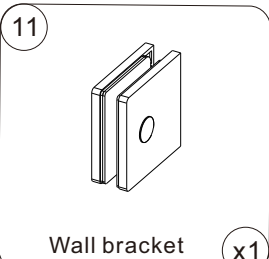
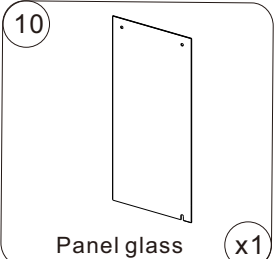
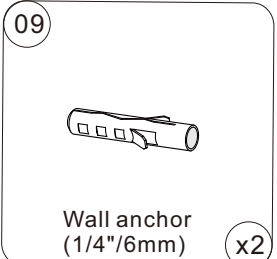
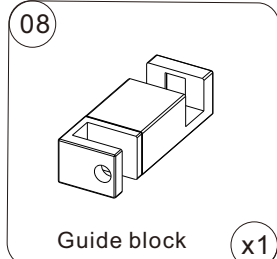
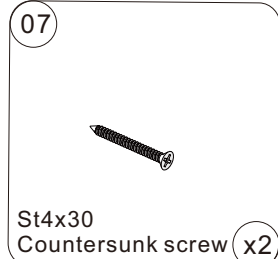
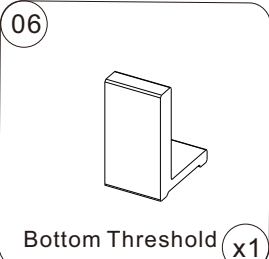
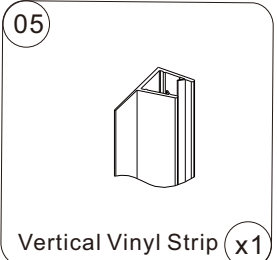
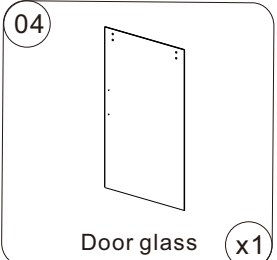
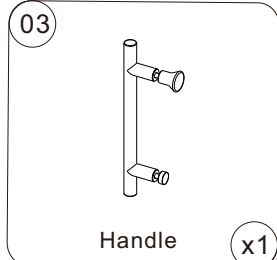
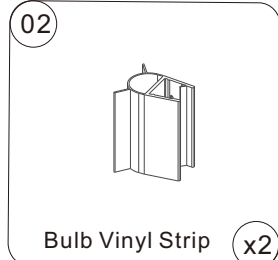
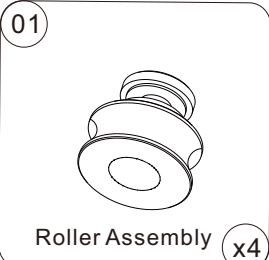
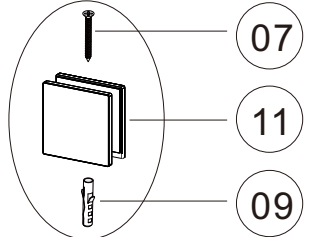
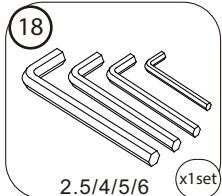
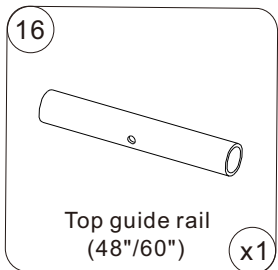
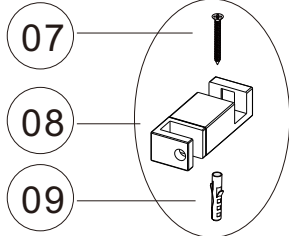
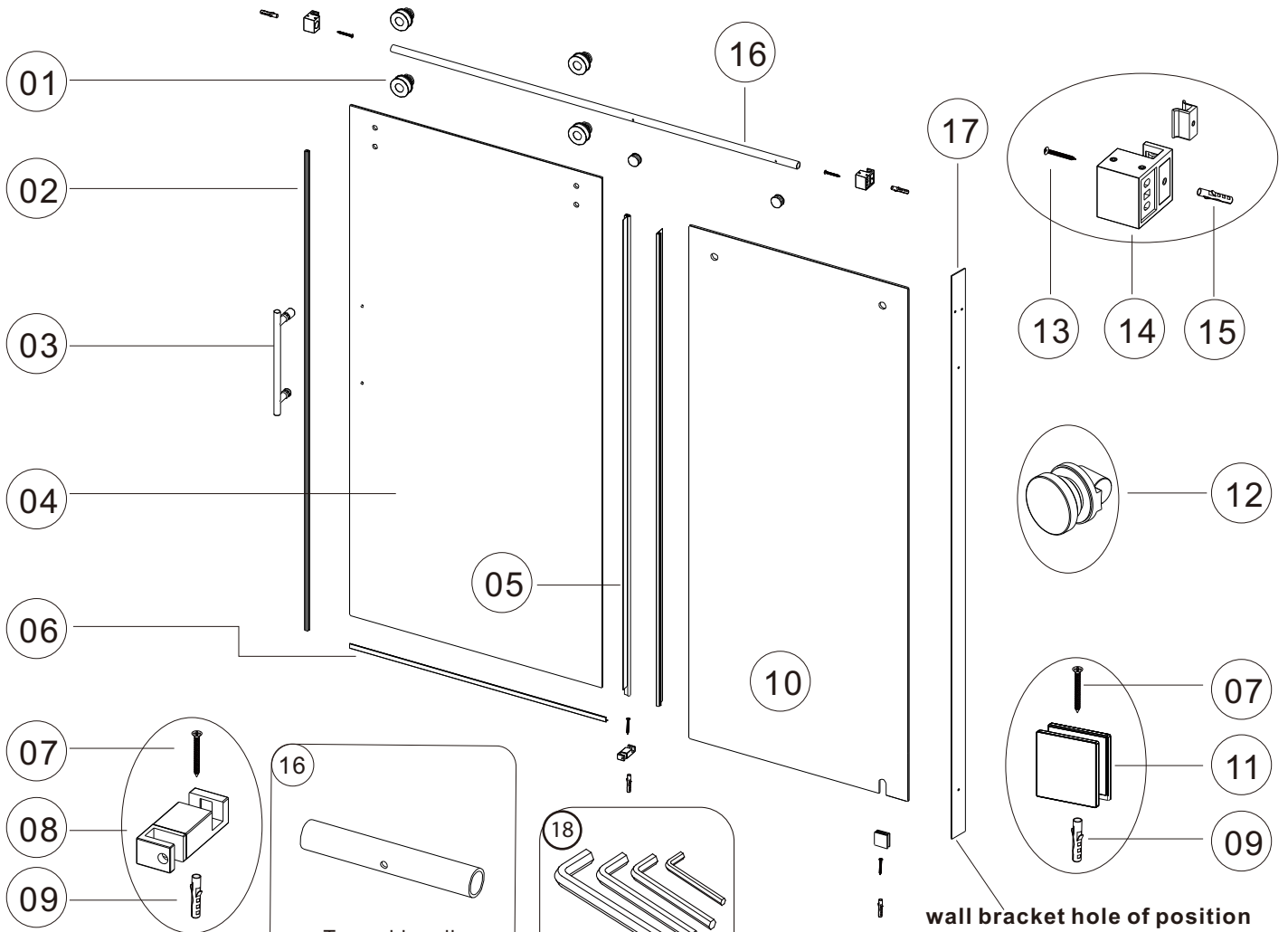

Confirm The Tray & The Wall Level

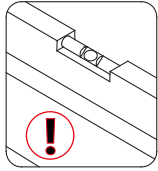
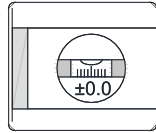

Threshold must be level

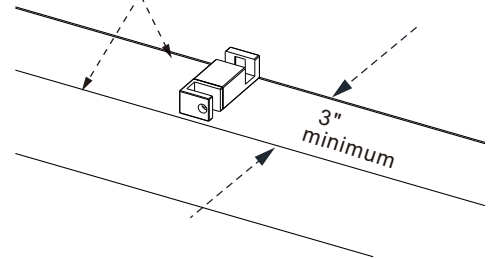
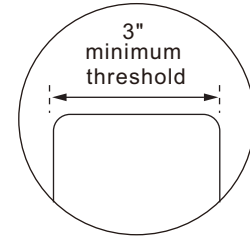
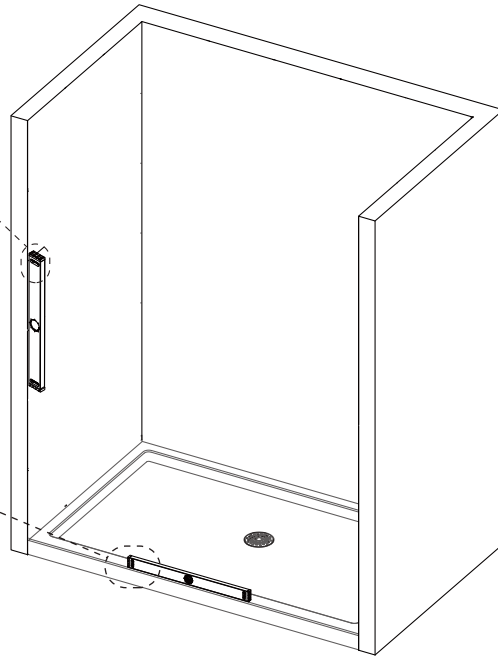

NOTE

The minimum threshold requirement for the S02 is 3" of flat threshold space.

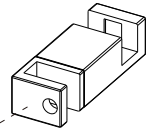

outer surface

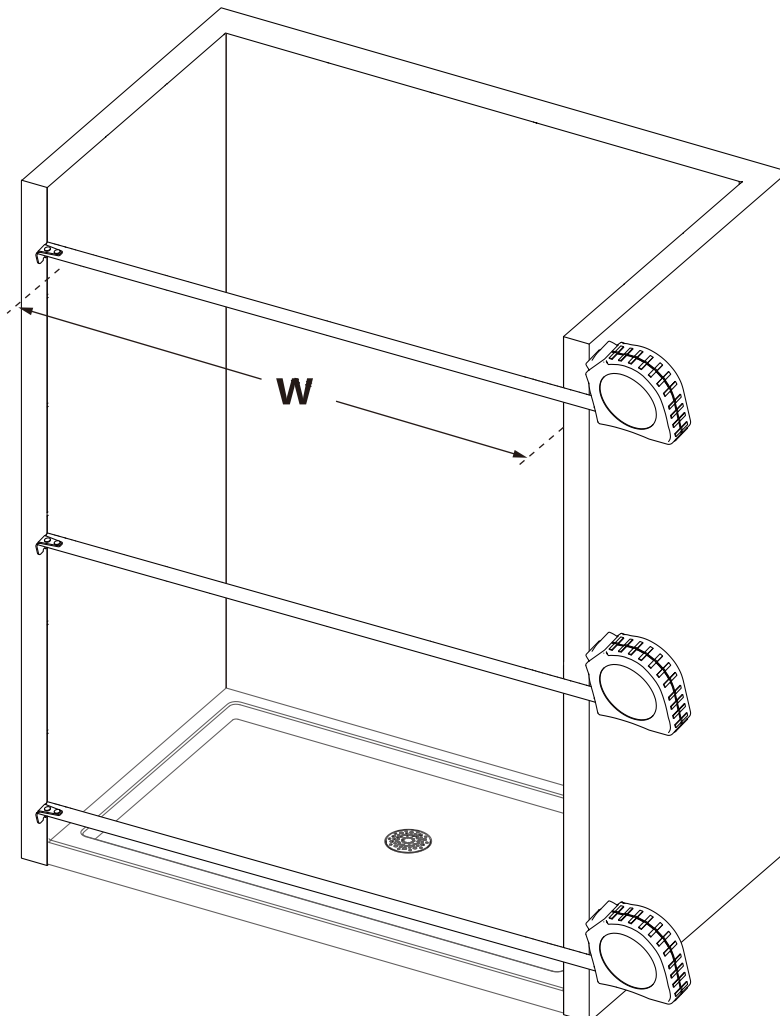
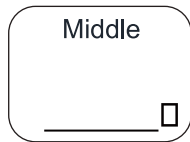
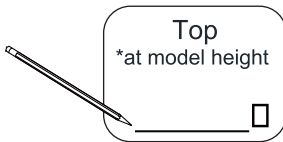

Tools Needed

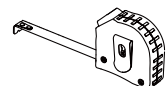

Measure And Cut The Top Guide Rail

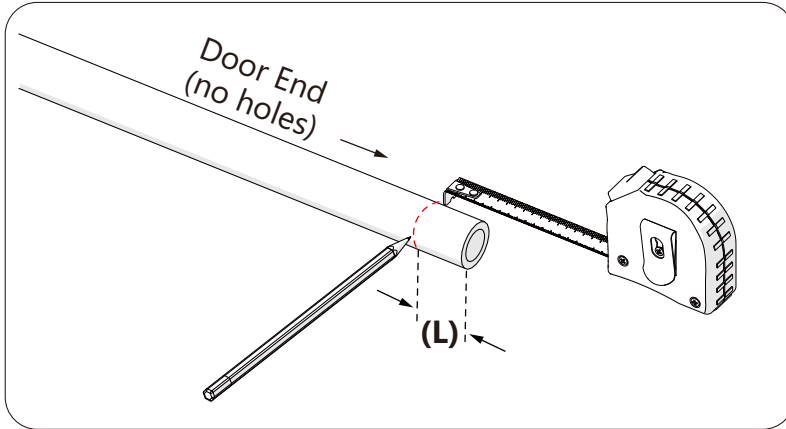

Use a metal file to deburr the cut end

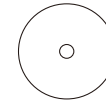

**Use the proper saw blade to cut stainless steel.

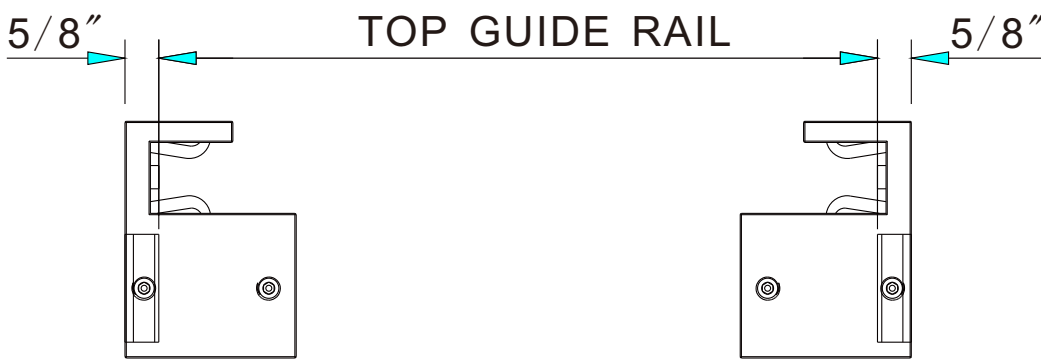
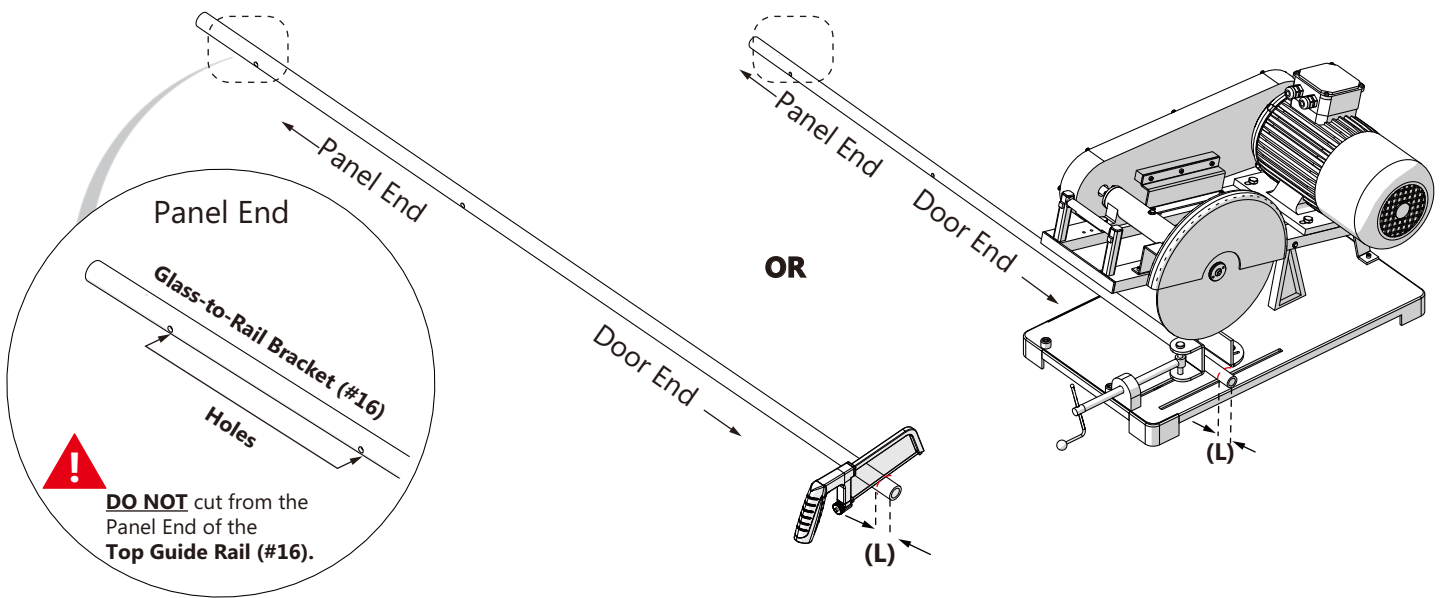

Tools Needed

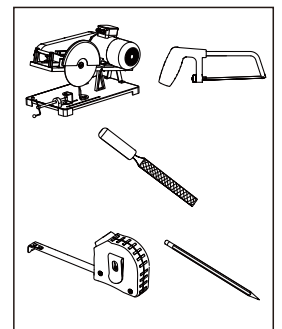
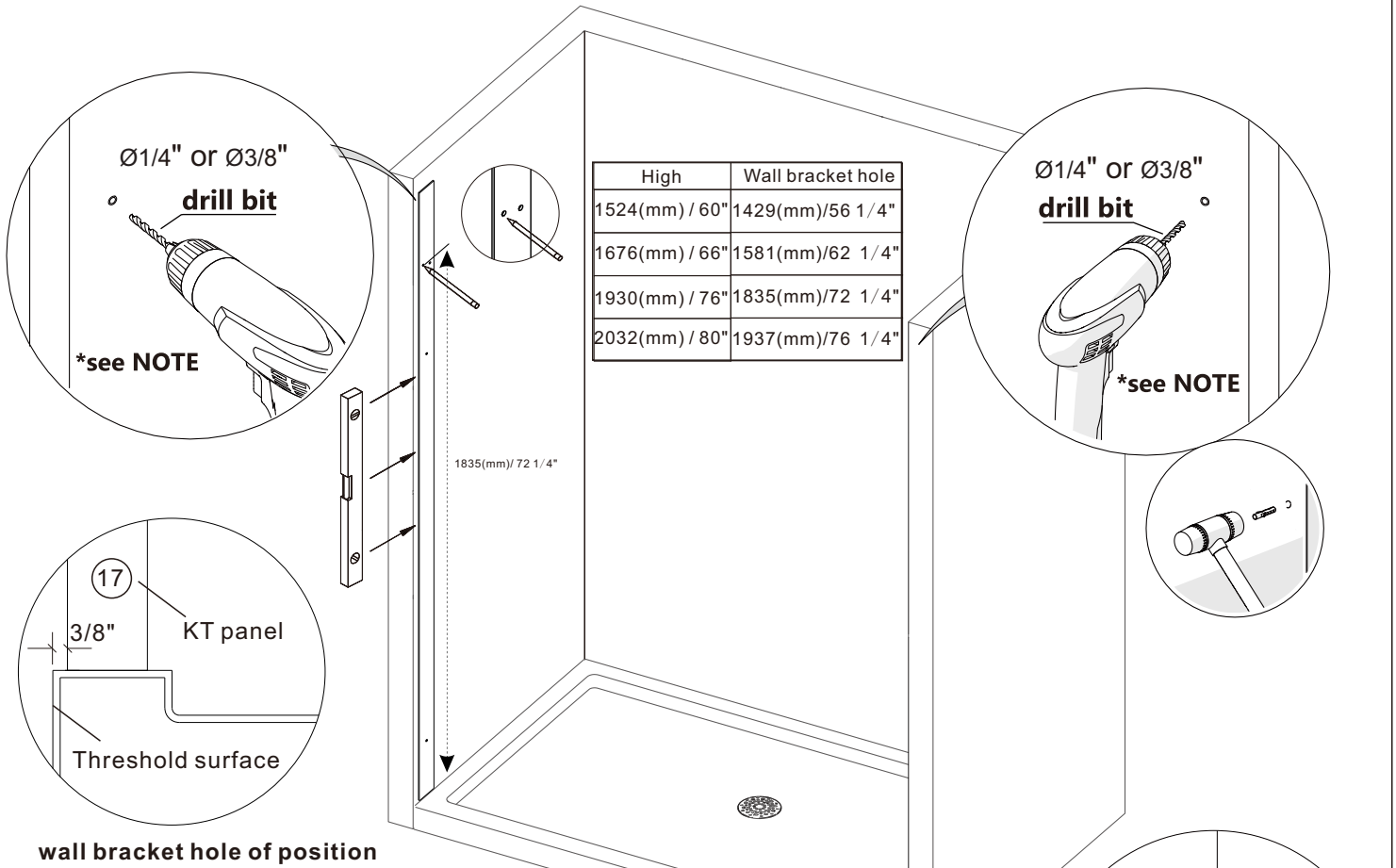

Table of top guide rail

No.	Type	width	Top guide rail	Adjustments
01	shower door	1219(mm) / 48"	1190(mm)/46 5/8"	(1118-1219)mm/ 44"- 48"
02		1422(mm) / 56"	1390(mm)/54 5/8"	(1320-1422)mm/ 52"- 56"
03		1524(mm) / 60"	1490(mm)/58 5/8"	(1422-1524)mm/ 56"- 60"

Measure Wall Bracket Hole



- For installation into an **Acrylic Threshold**:
drill a **Ø1/8" (3mm)** hole and use the **ST4.2 x 40mm Countersunk Screw**
- OR**
- For installation into a **Tile Threshold**:
drill a **Ø3/16" (4mm)** hole up to the stud and use the **ST4.2 x 40mm Countersunk Screw**

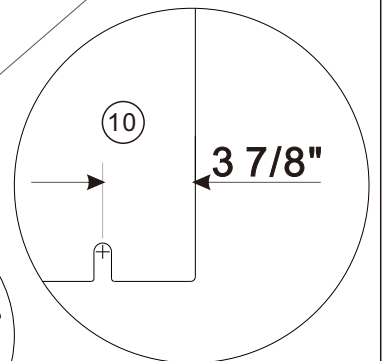
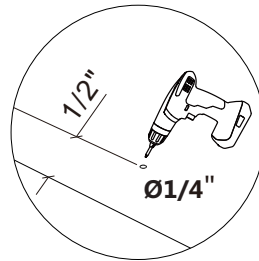
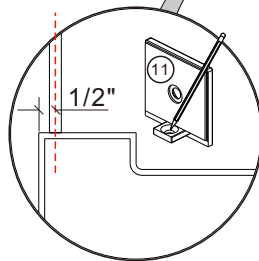

For Guide Rail Brackets:

- If a stud is present behind the wall:**
drill a **Ø1/4" (6mm)** hole up to the stud. (recommended)
- OR**
- If no stud is present behind the wall:**
drill a **Ø3/8" (7mm)** hole and install the **Wall Anchor**.

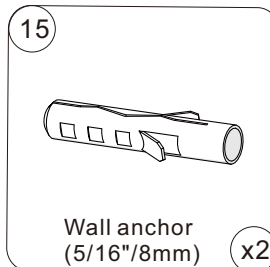

For Wall Brackets:

- If a stud is present behind the wall:**
drill a **Ø3/16" (4mm)** hole up to the stud.
- OR**
- If no stud is present behind the wall:**
drill a **Ø5/16" (8mm)** hole and install the **Wall Anchor**.

Tools Needed

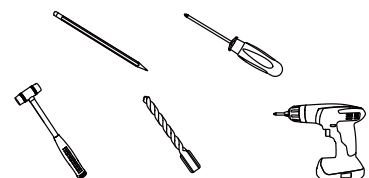

Wall Bracket Assembly & Roller of Installation

NOTE Leave the corner protectors on the glass until it is necessary to remove them

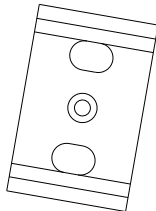
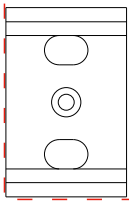
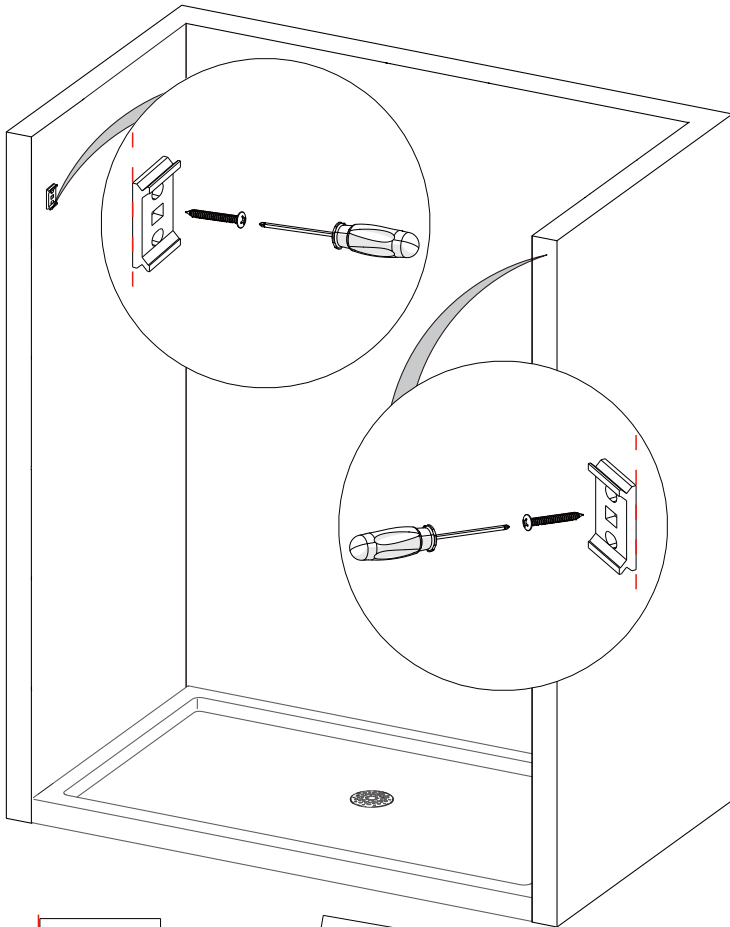

 **CORRECT** - recommended.

 **INCORRECT** - not recommended.



The adjustment set screws within the Guide Rail Bracket (#14) must be aligned vertically for easier access to adjust for level if necessary after the glass is installed. Align the set screws vertically and tighten.

DO NOT attach the handle to the Door Glass until instructed.
DO NOT attempt to lift the Door Glass with the handle as this may result in damage to the glass and/or serious personal injury. Use a professional grade glass suction cup and an assistant.

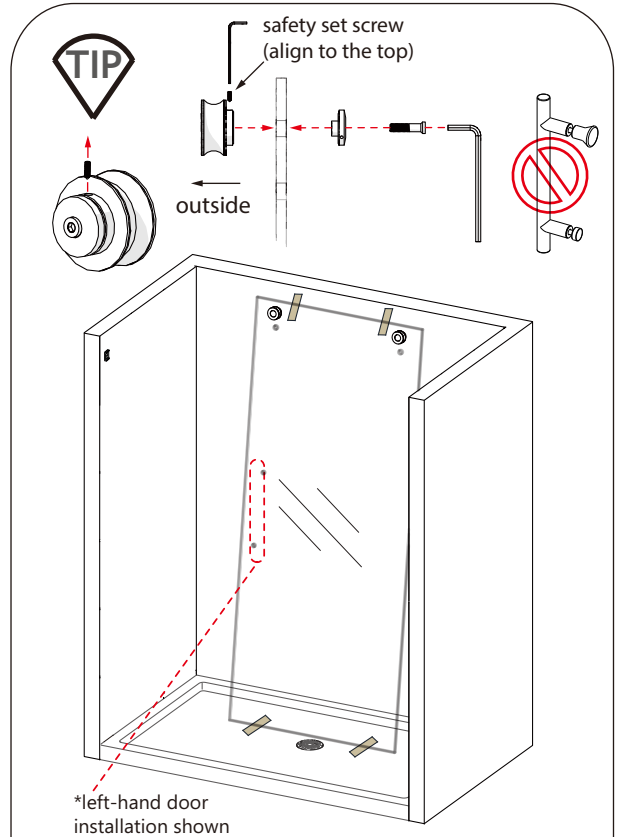

Before you install the **Panel Glass (#10)**, attach the top **Roller Assemblies (#01)** to the **Door Glass (#04)** with the wheels facing outside of the shower. Align the **safety set screw** towards the top for easier access. Then, take the **Door Glass (#04)** into the shower area and lean it against the wall with the handle holes on the correct side. Always use padding to protect the glass and shower surfaces.

Parts Needed

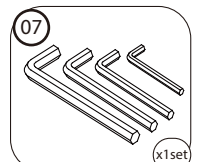
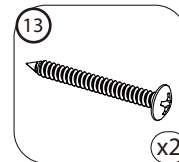
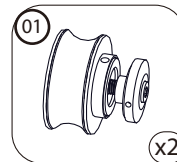

Tools Needed

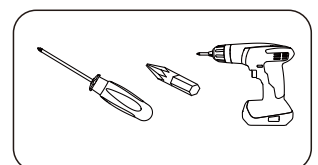

Top Guide Rail & Panel Glass of Installation

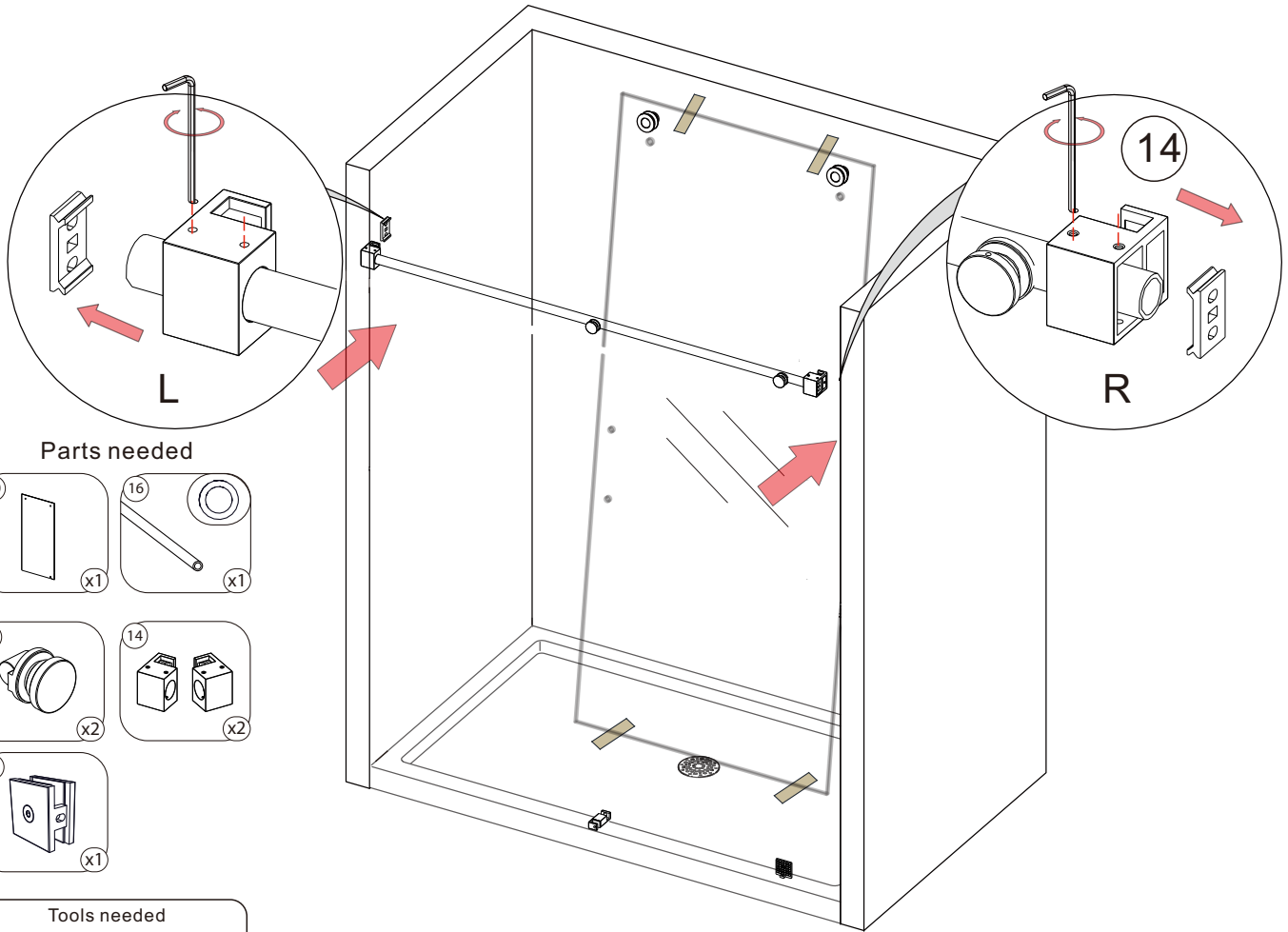

Parts needed

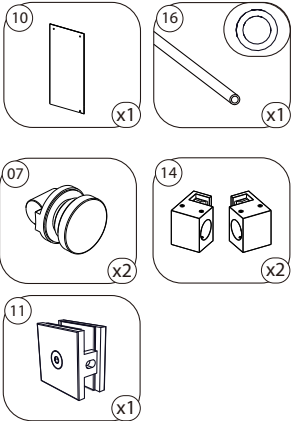

Tools needed



*Left-hand door installation shown

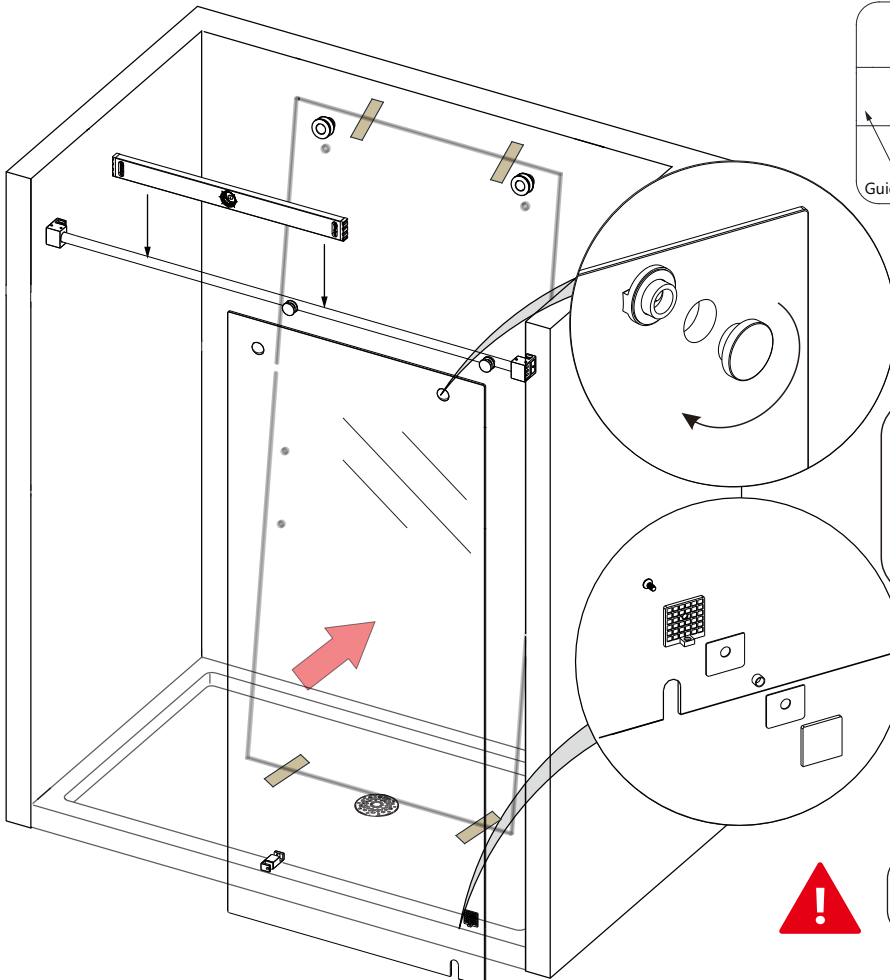
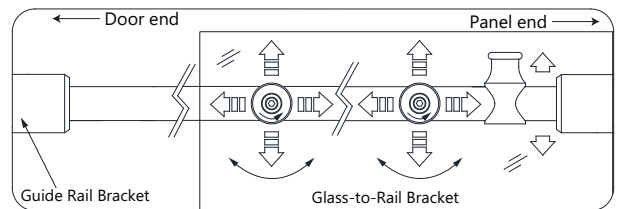

Adjust the installed **Top Guide Rail (#16)** to level as necessary using the **Guide Rail Brackets (#14)** first and then the **Glass-to-Rail Brackets (#12)**. **Start adjustments from the door end.**



The **Panel Glass (#10)** must be installed to the **outside** of the **Top Guide Rail (#16)**.

Bottom Threshold Strip & Bottom Guide of Installation

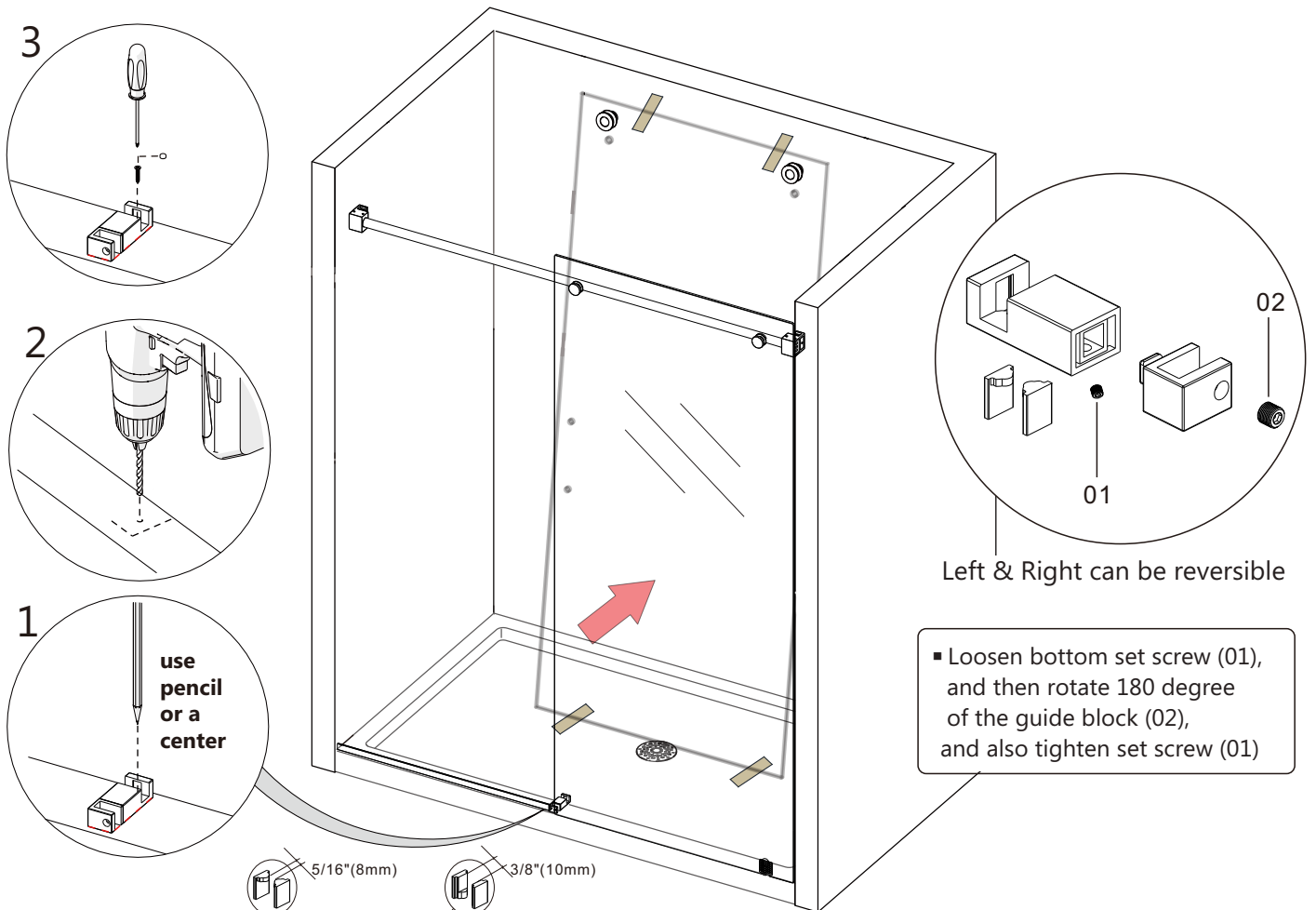

Left & Right can be reversible

Loosen bottom set screw (01), and then rotate 180 degree of the guide block (02), and also tighten set screw (01)

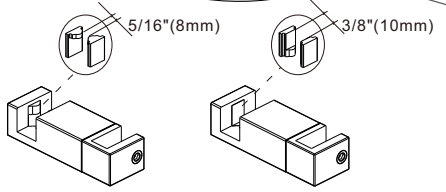

For installation into an **Acrylic Threshold**: drill a $\varnothing 1/8"$ (3mm) hole and use the **ST4.2 x 30mm Countersunk Screw (#07)**.
OR
 For installation into a **Tile Threshold**: drill a $\varnothing 3/16"$ (4mm) hole up to the stud and use the **ST4.2 x 30mm Countersunk Screw (#07)**.

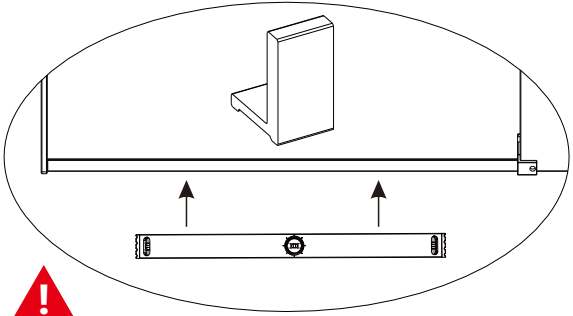
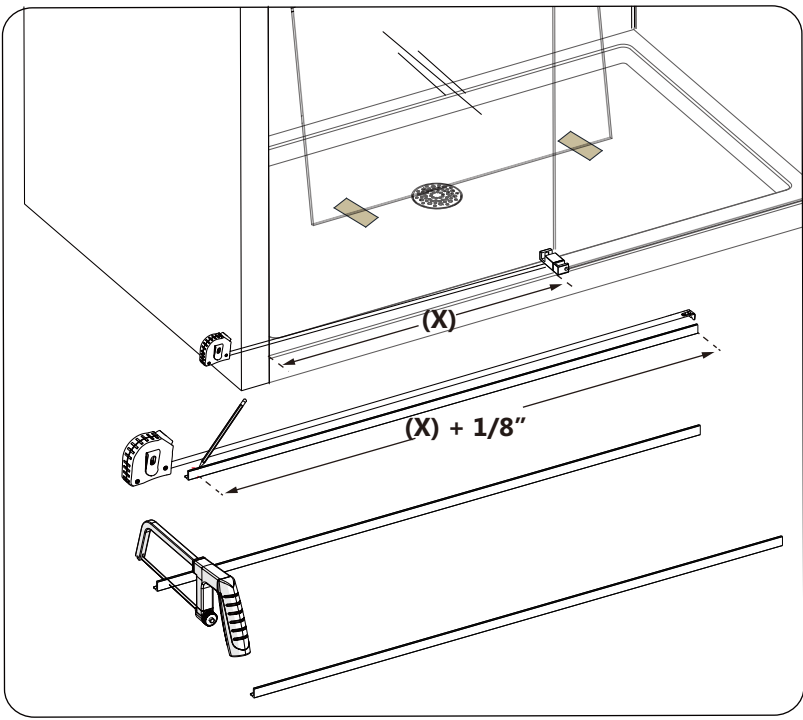

! Bottom threshold strip must be level

! Measure the distance 'X' from the **Guide Block (#08)** to the wall and add 1/8".

Tools needed

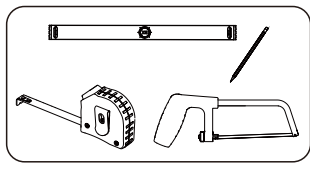

Parts needed

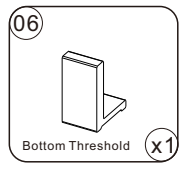

Upper Roller Assembly Installation

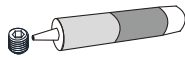
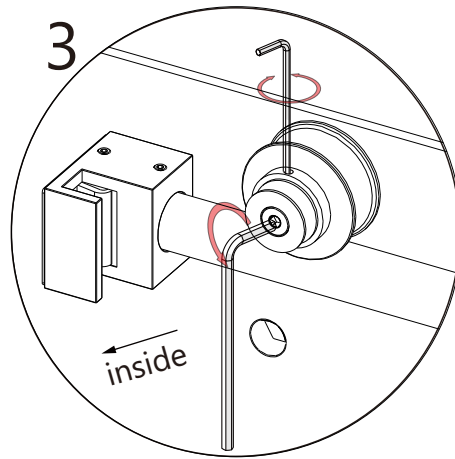
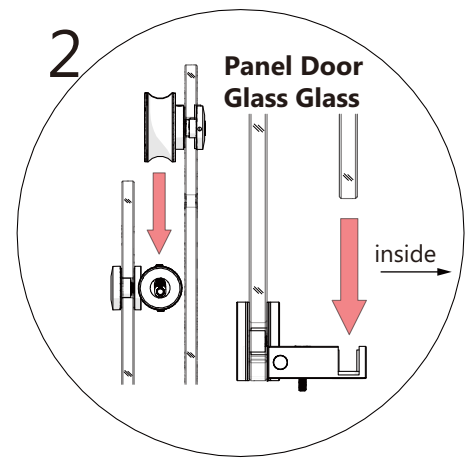
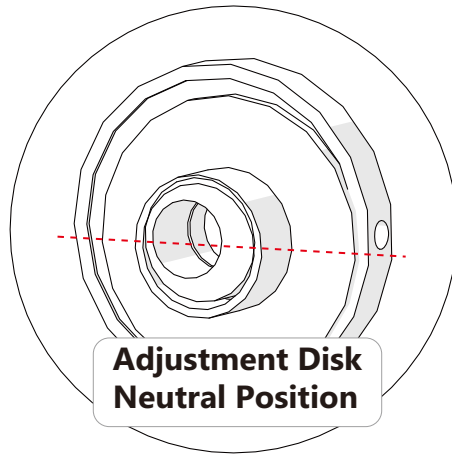
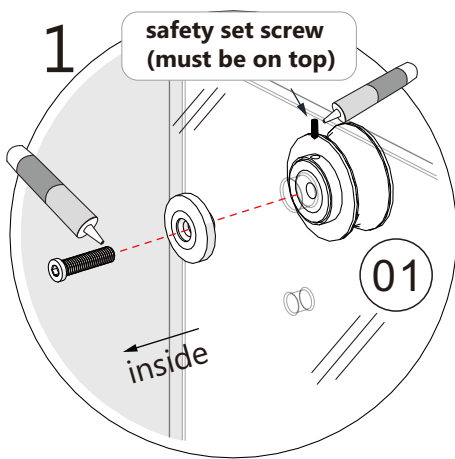

add thread lock to the safety set screw and wheel bolt

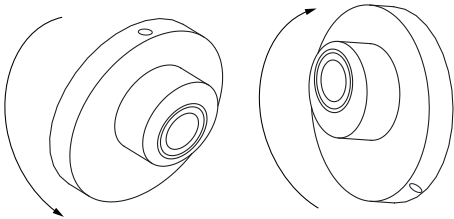

Lower glass Raise glass
Roller Assembly Wheel Adjustment

Mark the location of the high spot on the outer surface of the adjustment disk with a felt tip

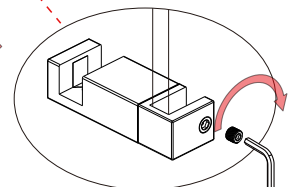
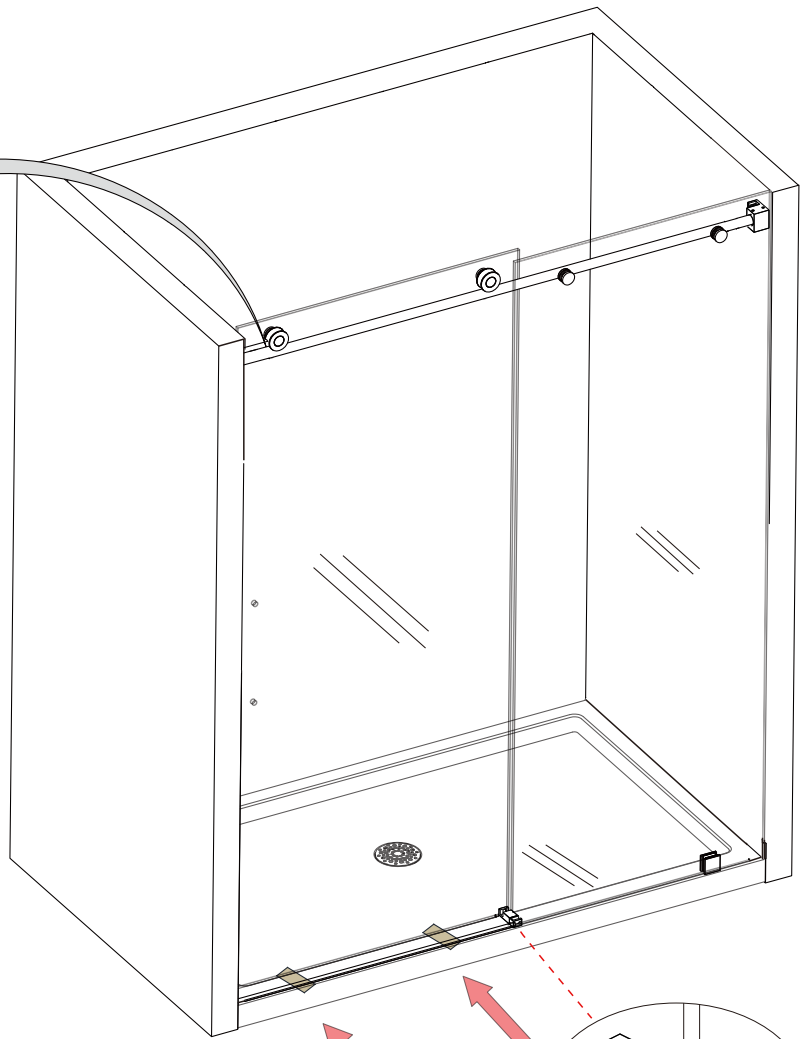

The adjustment disks in the wheels are the same as the disks in the Glass-to-Rail Brackets and can be rotated to adjust the **Door Glass (#04)** to create a seal with the wall. The **Safety Set Screw on both Roller Assembly Wheels MUST be re-tightened after installation** to prevent the wheel bolt from becoming loose. Apply **Thread Lock Adhesive** during installation.

Lower Roller Assembly Installation

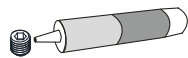
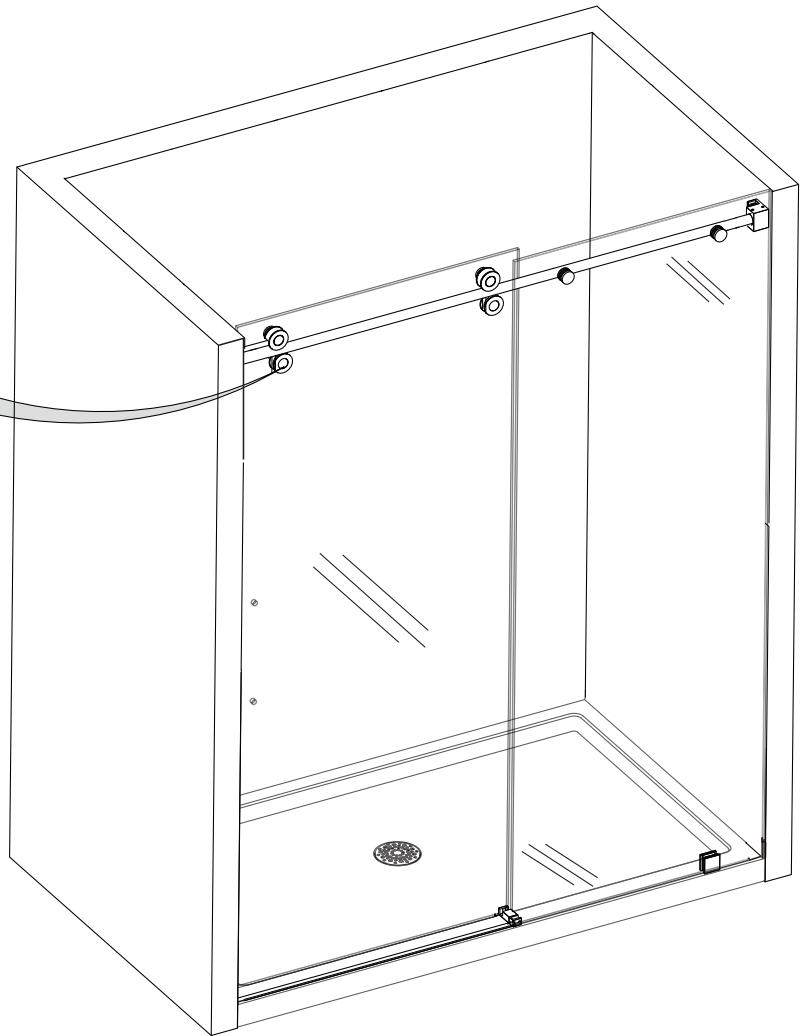
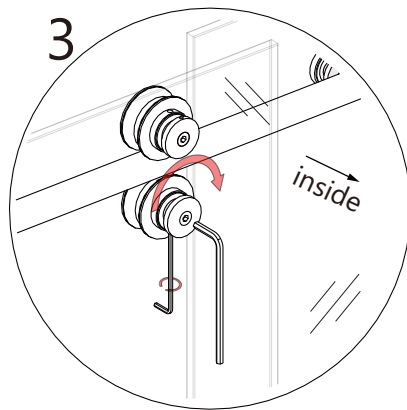
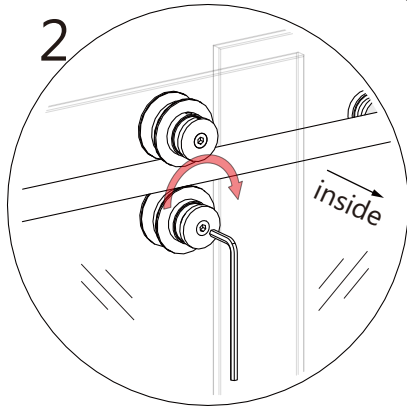
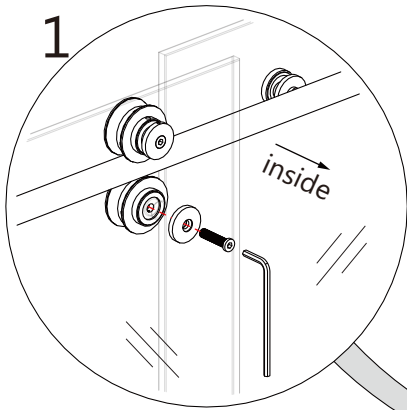

add thread lock to the safety set screw and wheel bolt

Mark the location of the high spot on the outer surface of the adjustment disk with a felt tip pen to make adjustment easier to see.

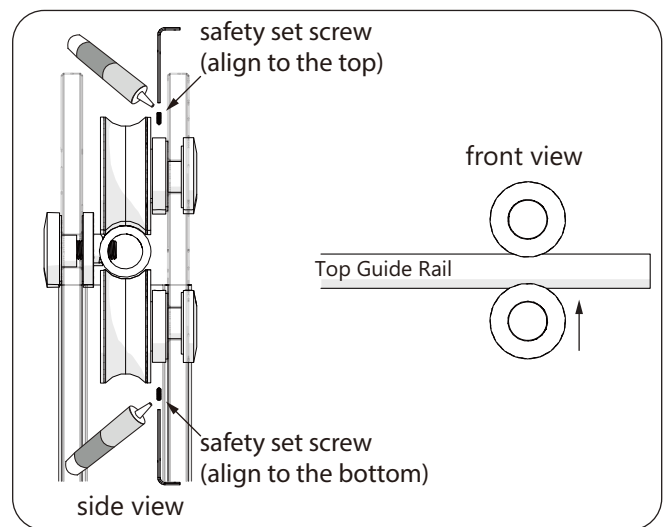

The adjustment disks in the wheels are the same as the disks in the Glass-to-Rail Brackets and can be rotated to adjust the **Door Glass (#04)** to create a seal with the wall. The **Safety Set Screw on both Roller Assembly Wheels MUST be re-tightened after installation** to prevent the wheel bolt from becoming loose. Apply **Thread Lock Adhesive** during installation.

Roller Assembly Adjustment Procedure

To create a good seal with the wall and to achieve minimal clearance beneath the door glass without making contact with the bottom guide block or threshold.

Have at least two 3/16" shims or wedge shims (to maintain space beneath the door glass) and an assistant available to help with this procedure.

Adjust only one wheel at a time. You may need to perform these steps more than once to get the desired results.

NOTE: Be sure to install the Bulb Vinyl Seal onto the edge of the door glass to protect the edge from contact with the wall during installation or adjustment.



CAUTION: The door glass is heavy and may require two people to safely accomplish these steps. **DO NOT** adjust the Roller Assemblies without first securing the door glass with shims, an assistant or both.

1. First, loosen and lower either the Roller Guards or Bottom Rollers to allow enough room to adjust the upper rollers.
2. Loosen the safety set screw on the roller (remove and apply a drop of thread lock if not done already)
3. Loosen the wheel bolt just enough so that you can rotate the adjustment disk. (remove and apply a drop of thread lock if not done already)
4. Rotate the adjustment disk to raise or lower the door slightly with help from an assistant. You can use a small tool (like an allen wrench) to aid in turning this disk by inserting it into the small hole on the edge of the adjustment disk.
5. While holding the adjustment disk in place, retighten the wheel bolt. Use a shim or have an assistant hold the door glass in place while you retighten the wheel bolt.
6. Once satisfied with the adjustment, **it is very important to re-tighten the safety set screw** to secure the wheel bolt in place.
7. Reposition the bottom roller approximately 1/16" beneath the guide rail and retighten. adjust the lower rollers to make contact with the guide rail using the same methods as described in the steps

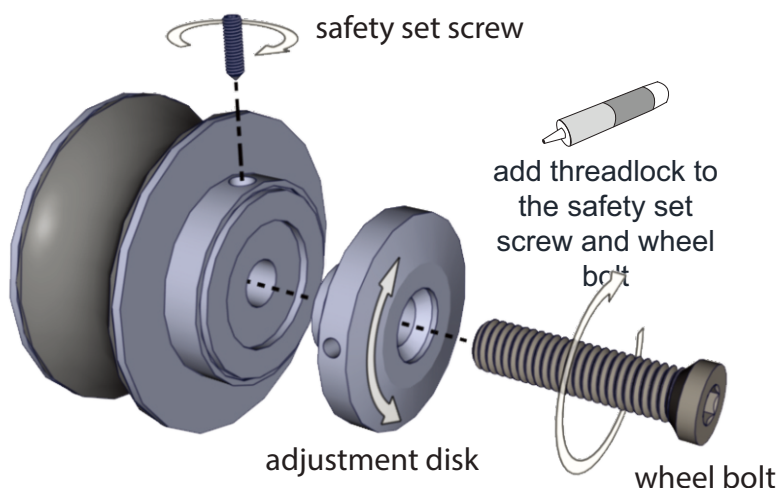

The provided Thread Lock will remain workable for approximately 10-15 minutes before drying.

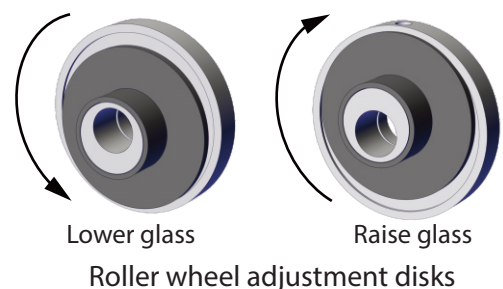

Vinyl Seals & Handle Installation

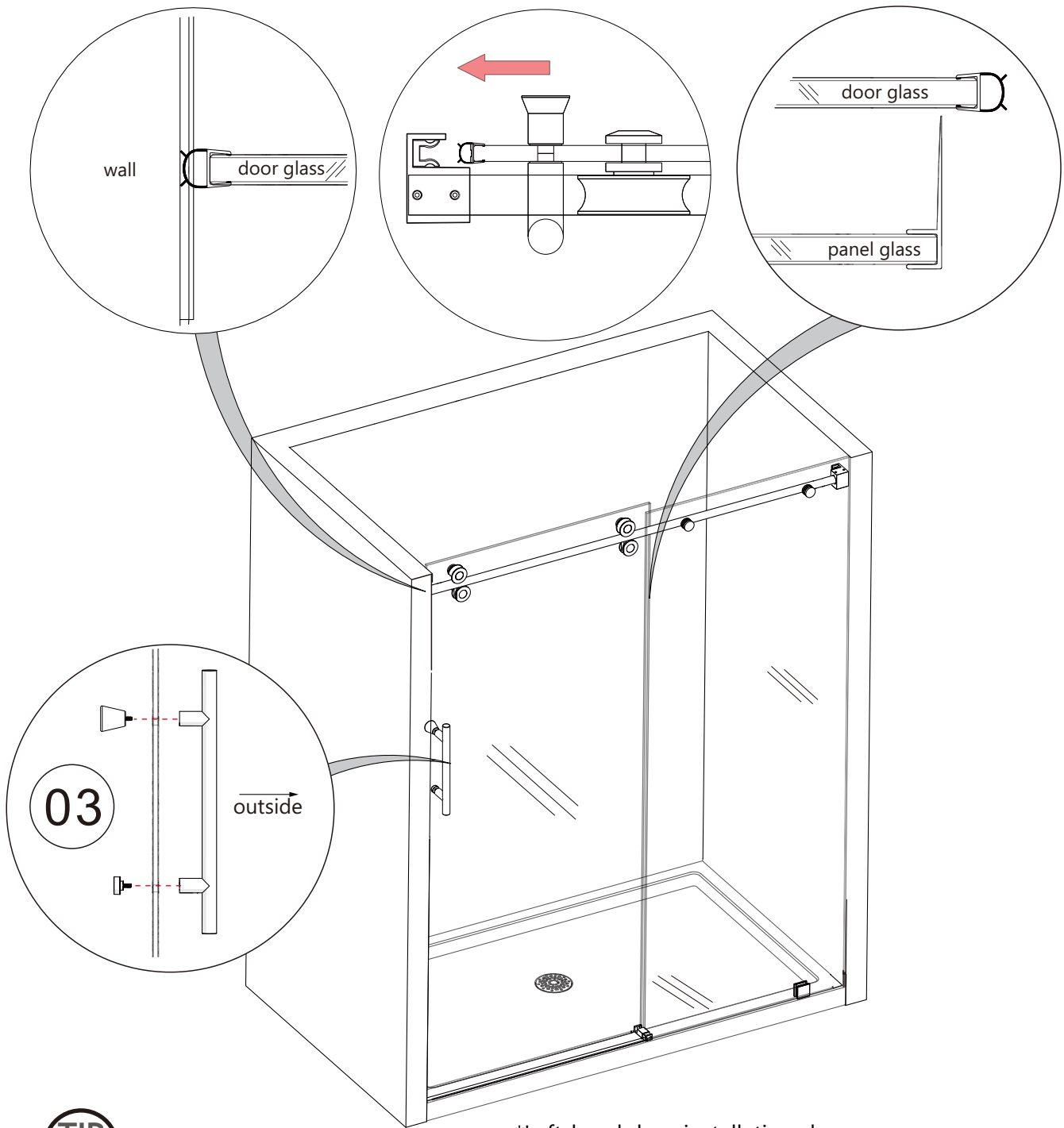

*Left-hand door installation shown.

Use a razor knife to trim the **Vertical Vinyl Seal (#05)** at the top to avoid interfering with the **Lower roller (#01)** and at the bottom where the door meets the **top guide rail (#16)**.

Parts Needed

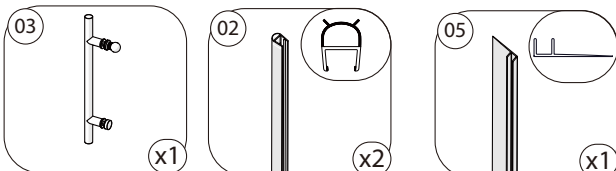

Tools Needed

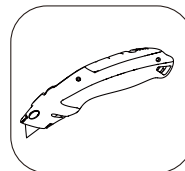



The surfaces need to be clean and free of debris before applying silicone.

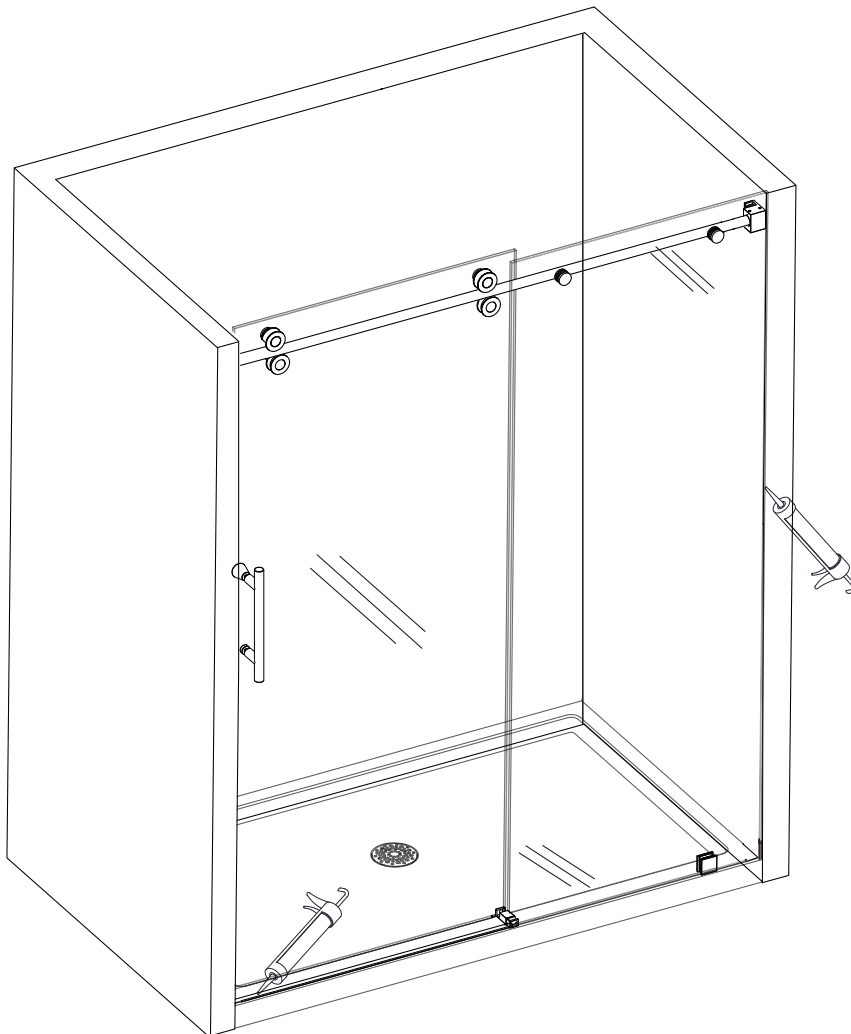

Allow 24 hours for the silicone to cure before using the shower.



DO NOT hang or drape a towel or wash cloth over the Top Guide Rail as this may cause the Roller Assembly wheels to get stuck and possibly cause serious damage or injury.

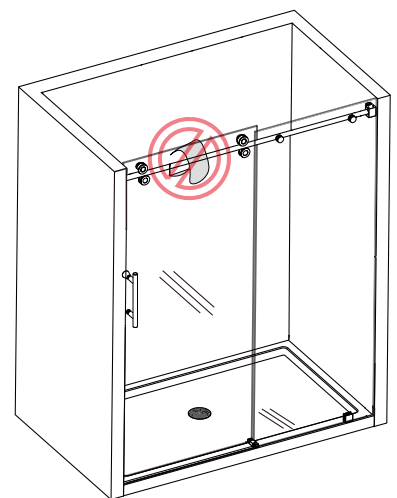

Product Care & Maintenance

- **Glass Panels**

After each shower, rinse and wipe the glass with a soft cloth or squeegee
To prevent soap residue and water spots.

Hard water left to dry can cause permanent etching—drying after use is
Highly recommended.

Do not use abrasive cleaners, scouring powders, bristle brushes, or
Abrasive sponges that may scratch the glass.

- **Hardware & Metal Finishes**

Wipe metal parts dry with a soft cloth after each use to maintain their finish.

Avoid cleaners containing ammonia, bleach, or acids. If such cleaners

Come in contact, rinse immediately to prevent peeling or corrosion.

Clean stainless steel at least once a week. When using stainless steel

Polish, always wipe in the direction of the grain.

Never use steel wool, wired brushes, or abrasive pads on metal surfaces.

Maintenance Checklist

- Ensure the unit is stable, operates smoothly, and is securely installed
- Verify panel glass and brackets are properly secured
- Check guide block alignment with the threshold and glass
- Confirm proper clearance beneath the door glass
- Inspect screws and tighten if needed
- Inspect vinyl seals; replace if damaged or missing
- Examine all glass edges for chips or cracks
- Replace any damaged glass immediately

Troubleshooting

Problem/Symptom	Suggested Solution
Missing Parts	<ul style="list-style-type: none"> •Check all shipping/packaging material for missing parts/components. •If not found, contact TEL:909-282-5408 to order factory part replacement.
Top Guide Rail was cut too short or was cut from wrong end during installation.	<ul style="list-style-type: none"> •The Top Guide Rail (#16) is pre-cut for the model size, and will be shorter than the model width to allow for the Guide Rail Brackets (#14). •If the Top Guide Rail (#16) is cut too short or cut from the wrong end, contact TEL:909-282-5408 to order factory part replacement.
Water Leakage	<ul style="list-style-type: none"> •Confirm the Bottom Threshold (#06), Bulb Vinyl Strip (#02), and the Vertical Vinyl Strips (#05) are installed correctly. •Confirm that the entire unit has been properly sealed with silicone caulk; allow at least 24 hours to allow the silicone to cure and set before using the shower unit. •Direct the shower head/water flow away from the area.
The door rolls open or closed	<ul style="list-style-type: none"> •Check the Top Guide Rail (#16) for level. Adjust the Guide Rail Brackets (#14) •Adjust the Roller Wheel Assemblies (#01) on the door, if needed, to allow the door to seal evenly against the wall. •To influence the Top Guide Rail (#16) slightly, the innermost Glass-to-Rail Brackets (#12) can be adjusted. •Confirm the Guide Block (#08) is square to the Panel Glass (#10) and threshold.
The door does not track smoothly	<ul style="list-style-type: none"> •Confirm the Door Glass (#04) is not making contact with the bottom of the Guide Block (#08). •If the Door Glass (#04) needs to be raised, adjust the Roller Wheel Assemblies (#01) to raise it. •Be sure that there is nothing on the Top Guide Rail (#16) that could block the Roller Wheel Assemblies (#01). •Check the Bottom Roller Assemblies (#01) are 1/16" beneath the Top Guide Rail (#16) and are not making any contact with the Top Guide Rail (#16).
Mishandled glass	<ul style="list-style-type: none"> • Always take precautions when handling tempered glass. • A glass suction cup and an assistant are helpful when carrying large, heavy lites of glass. •Never allow tempered glass (especially the edges) to come in contact with any hard surface, which can cause chipping, splintering or complete glass failure. •Any damaged glass should be immediately replaced. •Do not use a shower with damaged glass. •Leave plastic corner protectors on the glass until ready to install. •Always protect the glass once removed from the box by padding the top and bottom of the glass with cardboard, styrofoam or other soft material until ready to install.

Do not return product to store. Contact us with any questions.

Add: 830 N. Central Avenue, Upland CA, 91786

Web: www.ibathwiller.com

Email: supports@ibathwiller.com

TEL: 909-282-5408