



SmartFridge 50

Full Glass Door User's Guide



Full Glass Door

Table of Contents

1. Description of the SmartFridge..... 3

 1.1 Adjustable Shelves..... 3

 1.2 Defrost Water Outlet..... 3

 1.3 Door Liner 3

 1.4 LED Control Panel 3

 1.5 Dimensions 3

2. Location and Ventilation Requirements 4

 2.1 Choosing the Right Location 4

 2.2 Ventilation – Basic Principles..... 4

3. Grounding Instructions 4

4. Installation 4

 4.1 Before Putting in Use..... 4

5. Use of the LED Control Panel 5

 5.1 Display 5

 5.2 Buttons 5

 5.3 Modes 5

 5.4 Special Features..... 6

6. Maintenance and Cleaning 7

 6.1 Cleaning the SmartFridge 7

 6.2 Reversing the Door Hinge 7

 6.3 Automatic Defrosting of the SmartFridge 7

 6.4 Turn Off the SmartFridge When Not in Use 7

7. Miscellaneous Information 8

 7.1 Instructions for Use 8

 7.2 We Care for the Environment 8

 7.3 Important Notes 8

 7.4 Disposal of SmartFridge..... 8

8. Troubleshooting Guide 9

9. Minibar Systems Contact Information 10

10. Proof of Purchase..... 11



1. Description of the SmartFridge



1.1 Adjustable Shelves

Shelves can be placed on the guides inside the SmartFridge as required. Perishable foods should be stored towards the back/rear of the shelves as this is the coldest location in the SmartFridge.

1.2 Defrost Water Outlet

The interior of the SmartFridge is cooled with a cooling plate mounted on or in the rear wall. Under the plate there is a channel and a drain water outlet for defrosting water. Regularly check the defrost water outlet and the drain channel for blockages. They should always be kept free and clean of food particles. If the drain outlet does become clogged, use a straw to clean it.

1.3 Door Liner

The standard door liner will consist of a full glass door and comes standard with a door handle.

1.4 LED Control Panel

The Control Panel has four buttons and a LED display. See *“Use of the LED Control Panel”* for more information.



1.5 Dimensions

Model	Height	Width	Depth
SmartFridge - 50 Full Glass Door	21" 534 mm	17" 432 mm	20.75" 527 mm



2. Location and Ventilation Requirements

The *SmartFridge User's Guide* details the criteria necessary for the installation of the SmartFridge. These details are essential for the efficient running of the SmartFridge's electronics and refrigeration systems ensuring its long life span and trouble free operation.

2.1 Choosing the Right Location

Place the SmartFridge in a dry and regularly ventilated room. Do not place the SmartFridge near a heat source and do not expose to direct sunlight.

2.2 Ventilation – Basic Principles

Ventilation occurs by convection. Convection is the movement of air caused by the tendency of hotter and less dense air to rise, and colder, denser air to sink under the influence of gravity, which consequently results in transfer of heat.

The exhaust vent must exit into free space in the room. It must not vent into an enclosed space such as a closet, case good or ceiling void, as the heat will be trapped. The SmartFridge must not be placed against a heating radiator, window, curtains, or in direct sunlight. Ventilation grills or slots must not be covered.

3. Grounding Instructions

The mains power outlet socket should be located within close proximity of the SmartFridge.

A standard AC mains outlet socket with safety ground is provided. The AC mains supply to the SmartFridge must be clean and stable.

The power cord that is supplied with the SmartFridge has the appropriate grounding conductor and grounding plug. The plug must be plugged into an appropriate wall outlet that has been installed and grounded in accordance with all existing local codes and ordinances. The required nominal voltage and frequency are indicated on the rating plate (inside the unit or on the exterior rear wall of the unit).

Consult a qualified electrician if in any doubt.

4. Installation

4.1 Before Putting in Use

BEFORE CONNECTING THE SMARTFRIDGE TO AN ELECTRICAL POWER SUPPLY LET IT STAND FOR 24 HOURS. THIS WILL REDUCE THE POSSIBILITY OF MALFUNCTIONS IN THE COOLING SYSTEM DUE TO TRANSPORT HANDLING.

Clean the SmartFridge thoroughly especially the interior (see "*Maintenance and Cleaning*"). In case the interior shelves are not correctly placed, rearrange as shown in "*Description of the SmartFridge*".



5. Use of the LED Control Panel

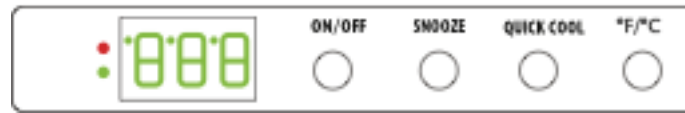

5.1 Display

The front panel consists of two LEDs (Green and Red), and a three character, seven-segment, LED display. The LEDs signify different operating conditions detailed below. The display shows the current temperature in the first two characters with the last character showing either “F” or “C” for Fahrenheit and Celsius. The left decimal point indicates the compressor is OFF. The right decimal point indicates the compressor is ON. “EL” indicates the temperature probe circuit is open. “EH” indicates the temperature probe has a short circuit.

5.2 Buttons

ON/OFF – Pressing the ON/OFF button will turn the SmartFridge on or off.

SNOOZE – Pressing the SNOOZE button will cause the SmartFridge to set the internal temperature to 50°F/10°C) for eight hours so the compressor does not run as often.

QUICK COOL – Pressing the QUICK COOL button will cause the SmartFridge to drive the internal temperature to 34°F/1°C. Once reached, the SmartFridge will operate in ON mode.

°F/°C – Pressing the °F/°C button will toggle the temperature display between degrees Fahrenheit or Celsius.

5.3 Modes

DOOR – Opening or closing the door will turn the interior lights on or off.

ON – The SmartFridge will chill between 37°F/2°C and 39°F/4°C. You can enter this mode by pressing the ON/OFF button from the ON mode. The green LED will be turned on while in this mode and the current temperature will be displayed. When the unit is put into service it is in the ON mode by default. The default temperature is 37°F/3°C ± 1°C.

OFF – The SmartFridge will chill between 58°F/14°C and 61°F/16°C. You can enter this mode by pressing the ON/OFF button from ON mode. The red LED will be turned on and the display will be blank. The default temperature is 59°F/15°C ± 1°C.

STOP – Press and hold the ON/OFF button for three seconds from the ON mode to shut down the SmartFridge. The red LED will flash for five seconds then turn off and the display will be blank.

SNOOZE – The SmartFridge will chill between 48°F/9°C and 52°F/11°C for eight hours. You can enter this mode by pressing the SNOOZE button from ON or QUICK COOL modes. The red LED will flash until SNOOZE is complete. Upon completion, the SmartFridge will return to the ON mode. The default temperature is 50°F/10°C ± 1°C.



QUICK COOL – The SmartFridge will chill until the temperature reaches 37°F/1°C. You can enter this mode by pressing the QUICK COOL button from ON or SNOOZE modes. The green LED will flash until QUICK COOL is complete. Upon completion, the SmartFridge will return to the ON mode. The default temperature is 37°F/1°C ± 1°C.

DEFROST – The SmartFridge shuts down the compressor every 12 hours for 30 minutes to allow for frost and ice built up on the chiller plate to melt. This is an automatic function that runs all the time unless in STOP and FAILURE modes.

FAILURE – If the SmartFridge detects a temperature probe malfunction, the LEDs and display flash, displaying “EL” or “EH.” Once the problem is fixed, the unit will return to the previous mode.

5.4 Special Features

- To reduce thrashing of the compressor, there is a 3-minute turn-on delay.
- Opening the door from OFF mode will switch the SmartFridge to ON mode.
- The display will turn off after 10 seconds of non-use.
- A GONG (Go/No Go) test is executed at power up. All the LEDs flash, and all the segments rotate on the display including the decimal points. The temperature probe is checked for a valid range or connection.
- If the temperature probe is out of range or not connected the SmartFridge will go to a FAILURE mode.
- The default operating temperature is 37°F/3°C for the solid door model; 41°F/5°C for the glass door model. You can change the default temperature by pressing the SNOOZE and QUICK COOL buttons at the same time and holding for three seconds. Both LEDs will turn on signifying you are in the Temperature Set mode. The current temperature setting saved in FLASH will be displayed. Pressing the SNOOZE button will increase the temperature, pressing the QUICK COOL button will decrease temperature. Press the SNOOZE and QUICK COOL buttons at the same time to exit Temperature Set mode. At this time the new temperature setting will be saved in FLASH. Minimum temperature allowed is 37°F/1°C and maximum is 48°F/9°C.
- The default temperature format can be switched between °F and °C by pressing and holding the QUICK COOL button for three seconds.



6. Maintenance and Cleaning

Disconnect the SmartFridge from the power supply before cleaning or attempting repairs.

6.1 Cleaning the SmartFridge

- Disconnect the power plug from outlet before cleaning the SmartFridge. Remove the contents.
- Use neutral cleaning agents to avoid damage to the SmartFridge liner and exterior surface.
- Clean the exterior with water and a neutral detergent.
- Remove the detachable accessories in the interior of the SmartFridge and clean with water and a neutral liquid detergent. Plastic parts cannot be washed in dishwashers.
- Wash the interior of the SmartFridge with lukewarm water adding one or two tablespoons of vinegar.
- After cleaning, reconnect the SmartFridge to the power supply. SmartFridge is now ready for use.

6.2 Reversing the Door Hinge

- Remove the four screws #3 from the bottom hinge #4. Gently take the door off from the top hinge #2. (See Diagram 1)
- Unscrew the top hinge #2 and fix it onto the opposite side. Remove two screws #1 on the door handle #5 and fix it onto the opposite side at the door top. (See Diagram 2)
- Put the door snapped onto the top hinge, and fix the bottom hinge at the opposite side. Make sure the door assembly is properly aligned then tightly fix the screws.

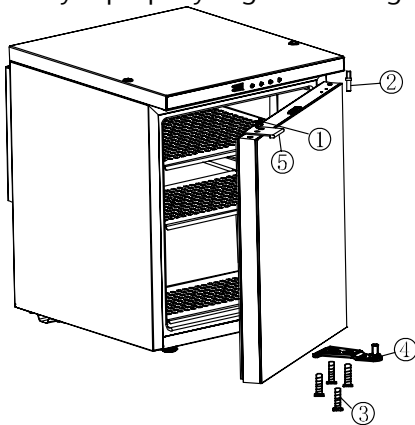

Diagram 1

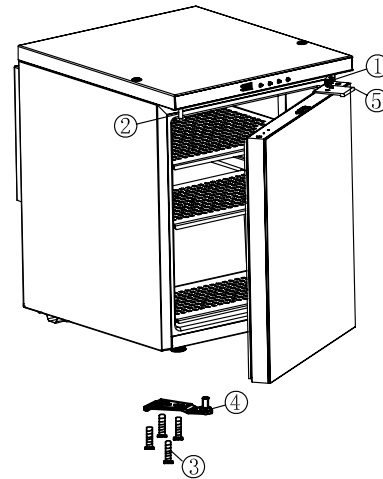

Diagram 2

6.3 Automatic Defrosting of the SmartFridge

There is no need to defrost the SmartFridge because ice depositing on the inner back wall is defrosted automatically. Ice build-up on the inner back wall during the compressor operation (when the compressor has cycled off) will defrost automatically. Defrost water collects inside the drain by passing through the drain outlet in the inner back wall into a drain pan situated above the compressor, from where it evaporates.

6.4 Turn Off the SmartFridge When Not in Use

If you do not intend to use the SmartFridge for long periods of time:

- Disconnect the power supply
- Take out the food and defrost
- Clean the SmartFridge
- Leave the door slightly open



7. Miscellaneous Information

7.1 Instructions for Use

These instructions are intended for the user. They describe the SmartFridge and correct operating procedures for safe use. **PLEASE SAVE THESE INSTRUCTIONS. NOT FOR OUTDOOR USE.**

7.2 We Care for the Environment

Our products use environmentally friendly packaging. Individual packaging materials are clearly marked.

These instructions are printed either on recycled paper or chlorine free bleached paper.

7.3 Important Notes

If you have bought this SmartFridge to replace an old one equipped with a door lock that cannot be opened from the inside (lock, bolt), make sure that the lock is removed, disabled or destroyed before discarding. This will make it impossible for children to accidentally lock themselves inside the SmartFridge and suffocate.

The SmartFridge must be properly connected to an electrical power supply (see "*Connection to power supply*").

Always disconnect the SmartFridge from the power supply before cleaning or attempting repairs.

NOTE: Repairs should be performed by qualified service personnel.

Do not defrost the SmartFridge with other electric appliances (for example, a hair dryer) and never attempt to scrape/remove ice or frost with sharp objects. Use only enclosed tools or tools recommended by the manufacturer.

The refrigerating system of the SmartFridge is filled with refrigerant and oil, so when the SmartFridge is damaged, handle it with care and dispose of it in compliance with environmental protection safeguards.

The rating plate containing Model Number/Serial Number and other technical data specific to this unit is located either inside the SmartFridge or outside on the rear wall.

Proper use of the SmartFridge, adequately packed food, correct temperature and taking into account hygienic precautions will substantially influence the quality of the food stored.

7.4 Disposal of SmartFridge

If you need to dispose the SmartFridge, please do so in a safe and harmless manner. If the SmartFridge is equipped with a door lock that cannot be opened from the inside (lock, bolt), make sure the lock is removed, disabled or destroyed before being discarded. This will make it impossible for children to accidentally lock themselves inside the SmartFridge and suffocate.

The SmartFridge cooling system is filled with refrigerant and insulating substances that must be disposed of legally. Contact the nearest waste facility for advice or requirements as regulated by local law. Be careful not to damage the tubes on the rear wall of the SmartFridge (danger of pollution).

IMPORTANT WARNING:

DANGER: RISK OF CHILD ENTRAPMENT. AN EMPTY REFRIGERATOR IS A VERY DANGEROUS ATTRACTION FOR CHILDREN. TO PREVENT CHILDREN FROM GETTING TRAPPED INSIDE, REMOVE DOORS, LOCKS, AND GASKET AND/OR TAKE SOME OTHER ACTION THAT WILL GUARANTEE IT HARMLESS BEFORE YOU DISPOSE OF YOUR REFRIGERATOR. LEAVE THE SHELVES IN PLACE.



8. Troubleshooting Guide

Please refer to this troubleshooting guide for the possible cause and solution to your problem. If you cannot resolve on your own, see “Minibar Systems Contact Information” at the end of this manual.

The SmartFridge fails to operate after connecting to electrical power supply:

- Check the power cord is properly connected.
- Check the power supply in the electrical outlet (blown fuse / circuit breaker).
- Make sure the SmartFridge is working.

Continuous operation of the cooling system:

- The door is frequently opened or left open for too long.
- The door is not properly closed (the door may sag; the gasket may be polluted or damaged).
- Perhaps you may have overloaded the SmartFridge with fresh food.
- The reason may be inadequate ventilation of the compressor (assure adequate air circulation).

Ice formation on the inner rear wall:

As long as the defrost water runs to the channel and through the outlet to the drain pan on the compressor, automatic defrosting of the SmartFridge is assured. In case ice formation on the inner back wall is increased 0.12” (3 mm) - 0.20” (5 mm) ice should be manually defrosted.

- Disconnect the SmartFridge from the power supply and leave the door open. Never use electric devices for defrosting and do not scrape the ice or frost layer with sharp objects.
- After defrosting is complete close the SmartFridge door and reconnect to power supply. The cause of increased ice formation may be one of the following:
 - the door does not seal well (clean the gasket if it is contaminated or replace if damaged)
 - the door is frequently opened or left open for too long
 - the food stored in the refrigerator was warm
 - the food or dish is touching the inner back wall.

Water is leaking from the SmartFridge:

If the discharge water outlet is clogged, or the defrost water drips over the channel, water will leak from the SmartFridge.

- Clean the clogged outlet, for example with a plastic straw or pipe cleaner.
- Manually defrost the increased ice layer (see “Ice formation on the inner rear wall”).

Noise:

A compressor-based refrigerator does produce a certain level of noise. How noisy the SmartFridge is depends on where it is placed, how it is used and how old the SmartFridge is. During the operation of the compressor the noise of the liquid is heard. This is a normal condition and does not relate to the lifetime of the SmartFridge. After starting the SmartFridge the operation of the compressor and the refrigerant flow may be louder - this does not mean that something is wrong and does not relate to the lifetime of the SmartFridge. Occasionally unusual and louder noise can be heard. This noise is often a consequence of incorrect installation, check that:

- the SmartFridge is level and installed on a firm solid base / floor;
- it does not touch the case good cabinet;
- the accessories on the interior have been placed correctly in their positions; and check, bottles, tins and other vessels are not touching each other causing rattling and/or vibrations.



Tips for energy savings:

- Do not open the door too often, especially in hot and humid weather. Close the door as soon as possible.
- Check SmartFridge ventilation on a regular basis to ensure adequate air circulation behind the SmartFridge (see “Choosing the Right Location” and “Ventilation Requirements” sections).
- Before loading the SmartFridge with warm foods, make sure that they are cooled to ambient temperature.
- If the gasket is damaged or the door seal is poor, energy consumption is substantially higher. Replace damaged door gaskets as soon as possible.
- Ensure the SmartFridge is correctly positioned in the room away from heat sources and direct sunlight (see “Choosing the Right Location”).

9. Minibar Systems Contact Information

Contact Customer Support if you would like: to return items for repair/replacement, general information, pricing, spare parts, order status or items that are under warranty.

United States

Customer Support

Hours of operation: Monday through Friday, 8:30 AM – 5:30 PM EST

Telephone: 301-309-1112

Fax: 301-309-9699

Email: customerservice@minibarNA.com

10. Proof of Purchase

HELP US HELP YOU...

Read this guide carefully.

It is intended to help you operate and maintain your new Fridge properly. Keep it handy to answer your questions. If you don't understand something or you need more assistance, please call:

Minibar Customer Service

301-309-1112

Keep proof of original purchase date with this guide to establish the warranty period. Write down the model and serial numbers. You'll find them on a plate located on the rear outside wall of the Fridge. Please write these numbers here:

Date of Purchase

Model Number

Serial Number

Use these numbers in any correspondence or service calls concerning your Fridge.

IF YOU NEED SERVICE

We're proud of our service and want you to be pleased. If for some reason you are not happy with the service you receive, here are some steps to follow for further assistance. Contact Customer Service if you are not pleased, write all the details, including your telephone number, and send it to:

Minibar Customer Service
Telephone: 301-309-1112
Fax: 301-309-9699
Email: customerservice@minibarNA.com