

ASSEMBLY INSTRUCTIONS

DINING TABLE

ASSEMBLY
REQUIREMENTS

2-Person
Assembly

90 Minutes
Assembly Time
(Approximate)



Thank you for purchasing our product!

Please refer and use this assembly instruction to assemble the product. Contact our customer service department in case there are any missing or damaged parts or hardware. Replacement parts are normally shipped within 2 or 3 days.



PRODUCTS PURCHASED THROUGH OUR AUTHORIZED VENDORS ONLY ARE ELIGIBLE FOR REPLACEMENT PARTS.

We appreciate your business!

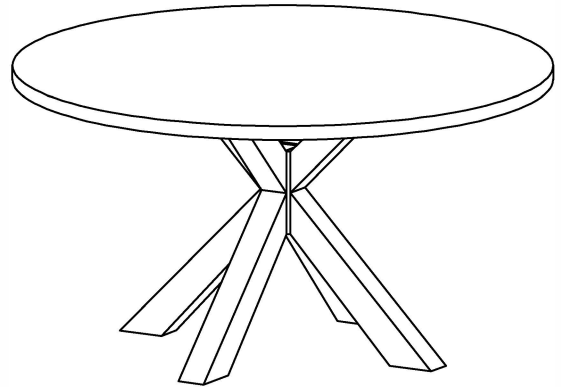

THIS PRODUCT IS FOR INDOOR AND HOUSEHOLD USE ONLY - NOT FOR COMMERCIAL USE.

ASSEMBLY PREPARATION

1. Remove all packaging materials, staples and packing straps from the carton.
2. Refer to Parts List and Hardware List, and ensure parts and hardware are correct before assembly. Contact customer service for missing parts.
3. Place all wooden parts on a clean, flat and soft surface (e.g. carpet or rug) to prevent scratch and damage to parts.

SAFETY PRECAUTION

1. KEEP ALL HARDWARE PARTS OUT OF REACH OF CHILDREN.
2. DISPOSE PLASTIC PACKAGING MATERIAL IMMEDIATELY TO AVOID ANY RISK OF SUFFOCATION TO CHILDREN AND ANIMALS.

TIPS FOR ASSEMBLY



1. Allow ample room for assembly and in close proximity to where product will be placed.
2. Assemble the product on a surface that does not scratch or damage the exterior gloss and finish of the furniture.
3. Identify all of the parts, hardware and quantities required for each step.
4. During assembly, do not over-tighten any fittings as this may cause damage.
5. **DO NOT USE POWER TOOLS TO ASSEMBLE THIS PRODUCT.**
6. Always place the product on a flat, level surface.
7. Do not sit or stand on the partially assembled product; only use the product for which it is intended.

CARE AND MAINTENANCE







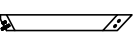
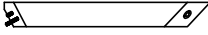

- Wipe clean with a soft, dry cloth; avoid the use of harsh chemicals or household cleaners as they may damage the exterior finish of the furniture.
- **Hardware may loosen over time. Periodically, check that all connections are tight; re-tighten as necessary.**
- Solid wood is impacted by heat and humidity fluctuations which may cause small joint separations or hairline cracks; place the furniture away from direct sunlight and air conditioning vents, heating vents or units to protect the furniture.

ASSEMBLY INSTRUCTIONS

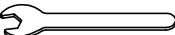
PARTS LIST

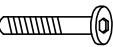
ITEM	PART NAME	QTY
1	TABLE TOP 	1 PC
2	HUB CAP 	1 PC
3	HUB POST 	1 PC
4	TOP SUPPORT ARM 	4 PCS
5	BOTTOM LEG 	4 PCS

HARDWARE LIST

NO.	DESCRIPTION	QTY	EXTRA
A	FLAT WASHER M8 	8	1
B	SPRING WASHER M8 	8	1
C	NUT 	8	1
D	SPANNER 	1	-
E	WOOD DOWEL M12 X30MM 	4	1
F	JCBC M6X40MM 	4	1
G	SPRING WASHER M6 	4	1
H	FLAT WASHER M6 	4	1
I	ALLEN KEY M4 	1	-

STEP 1

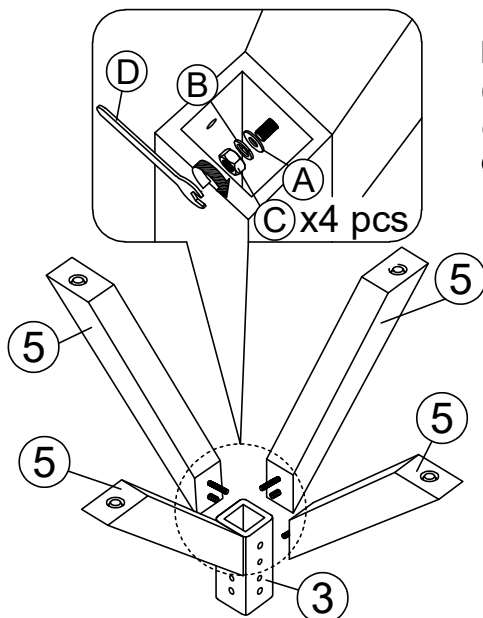

- a) With the assistance of another person, attach a Bottom Leg (5) with bolt and wood dowel to Hub Post (3) as shown.
- b) Fit Flat Washer (A) and Spring Washer (B) to the protruded bolt on (5) inside the Hub Post and fasten with Nut (C). Use Spanner (D) to drive and tighten (C). **DO NOT OVER-TIGHTEN.**
- c) Use the above produces to install the other three Bottom Leg.

STEP 2

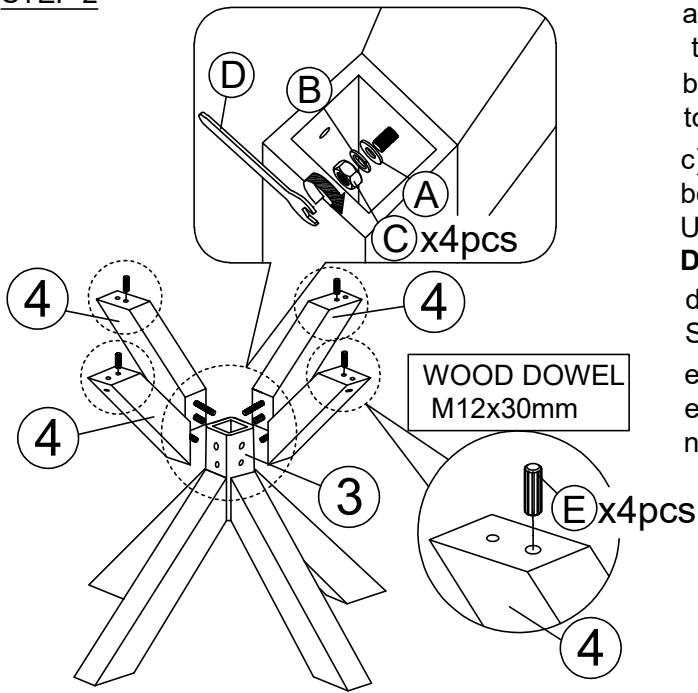

- Set the assembly from STEP 1 right-side up to stand on the four Bottom Leg.
- Attach a Top Support Arm (4) with bolt and wood dowel to Hub Post (3) as shown.
- Fit Flat Washer (A) and Spring Washer (B) to the protruded bolt on (4) inside the Hub Post (3) and fasten with Nut (C). Use Spanner (D) to drive and tighten (C). **DO NOT OVER-TIGHTEN.**
- Use the above procedures to install the other three Top Support Arm (4).
- Insert Wood Dowel (E) into the inner hole as shown on each Top Support Arm (4). Use a mallet to tap in (E) as needed.

STEP 3

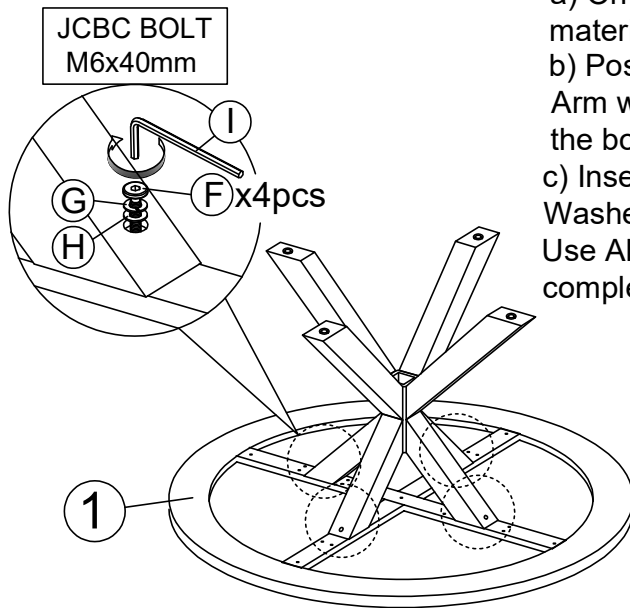

- On a flat surface, place Table Top (1) bottom-side up on a material that does not scratch the part.
- Position the assembly from STEP 2 to land the Top Support Arm with dowel to the designated hole on the cross-bar support on the bottom-side of (1) as shown.
- Insert JCBC Bolt (F) fitted with Spring Washer (G) and Flat Washer (H) through the bolt hole to fasten Top Support Arm to (1). Use Allen Key (I) to drive and tighten (F). Do not tighten (F) completely until all four screws are in place.

STEP 4

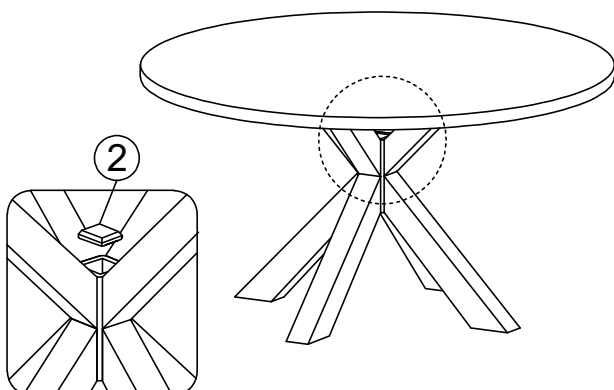

- Set the Table right-side up and affix Hub Cap (2) to cover the top opening of Hub Post.
- Level the table with Adjustable Leg Glide as needed.

The assembly of the table is complete.