

# ASSEMBLY INSTRUCTIONS

---

## TOOLS REQUIRED



Allen Wrench

(Included)

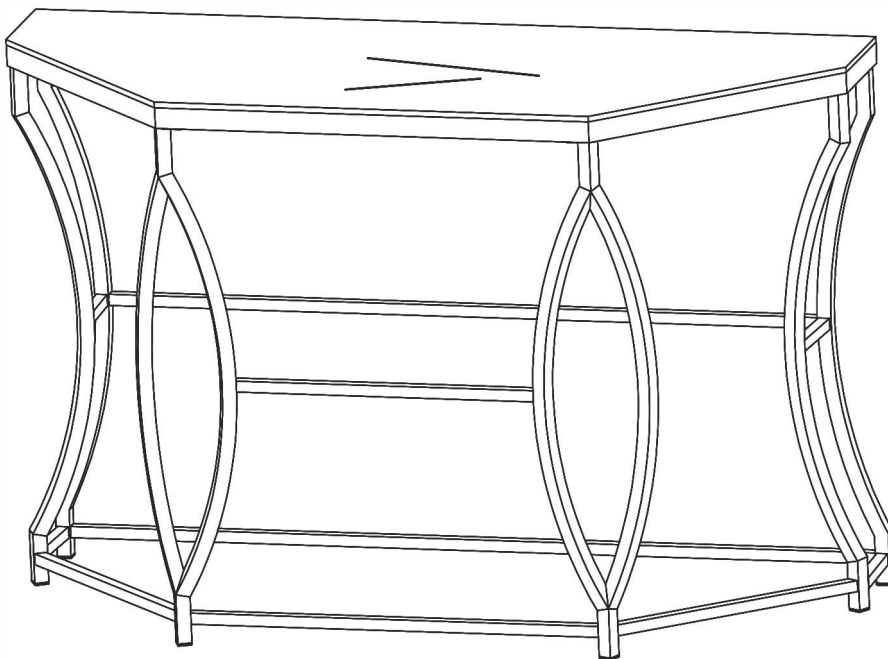

2 - People  
Recommended

## ASSEMBLY RATING



EASY —————> DIFFICULT

The Assembly Rating is a 5-point system showing the level of effort needed to assemble a specific product.



## **CHECK BEFORE STARTING**



### **Are you missing anything?**

Double-check all parts, hardware and accessories listed on Page 6 are accounted for.



### **Check out our Quick Tips!**

We recommend reviewing the pre-assembly handouts. Even experts need a refresher now and then!



### **Prep Time!**

Please review the assembly instructions and all diagrams prior to assembling. Arrange parts as recommended on Page 7 and group identical hardware together to make assembling easier.

# PRE ASSEMBLY INTRODUCTION

We understand building ready-to-assemble furniture can be a challenging experience for some. To help avoid confusion, we have provided some helpful tips that may speed up the process.

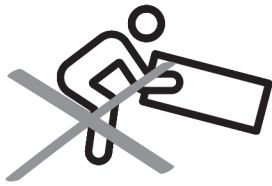

## Teamwork

ALWAYS have at least two people to help with transporting and assembling the product to avoid potential injury and/or damage.

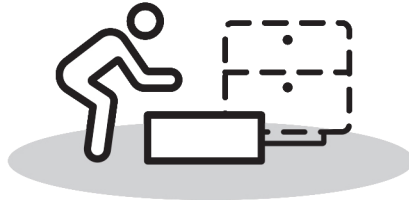
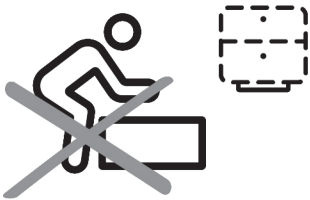

## Suitable Location

Assembling near the area of the intended location is highly recommended.



## Sufficient Space

Make sure you have enough space to move around during the assembly.



## Avoid Scratches

Use cardboard, blankets or a carpeted area while assembling furniture to prevent scratches.

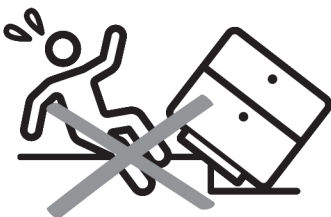

## Flat Surface

Make sure the furniture rests on a flat and level surface with each leg evenly touching the floor.

# ASSEMBLY AND CARE ADVICE



**FAILURE TO FOLLOW THE GUIDELINES BELOW MAY RESULT IN INJURY AND/OR PROPERTY DAMAGE.**



Position each part correctly and insert screws or bolts into their respective holes.

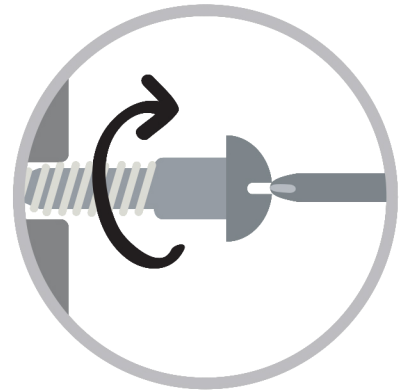

Turn clockwise to tighten and only tighten when step is completed or when instructed to do so.



Use the appropriate hand tools or power tools for assembly. Select steps, such as tightening screws and/or bolts, may require hand tools to avoid causing damage during assembly.



Save the instructions and store any supplied tools for later maintenance.

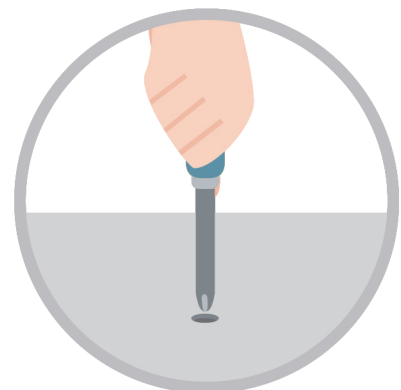

After two weeks, check and tighten any loose hardware and repeat again every six months thereafter.

**IT IS THE USER'S RESPONSIBILITY TO MAINTAIN THE FURNITURE. THE HARDWARE MAY LOOSEN OVER TIME AND MAY CAUSE THE FURNITURE TO BE WOBBLY AND UNABLE TO SUPPORT ITS INTENDED WEIGHT CAPACITY. THIS MAY LEAD TO COLLAPSE AND MAY CAUSE SERIOUS INJURY.**



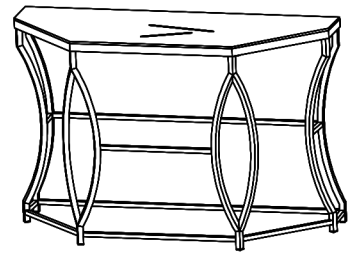



# CONSOLE TABLE



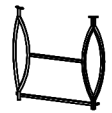

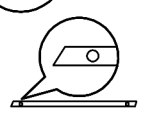
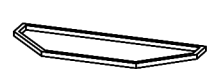
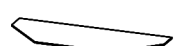

- Please keep instructions for future reference.
- Check the quantity and irregularity of parts and hardware before you start.

Due to the size and/or weight of this product, it is highly recommended that the assembly should be done near the area of its intended location. Make sure you have enough space to move around during the assembly. Always have at least two people to help with transporting and assembling the product to avoid any potential injury and/or damage.

## PARTS

<p><b>#1</b> 1pc</p>  <p>Front panel</p>	<p><b>#2</b> 1pc</p>  <p>Left panel</p>	<p><b>#3</b> 1pc</p>  <p>Right panel</p>	<p><b>#4</b> 1pc</p>  <p>Long stretcher</p>
<p><b>#5</b> 1pc</p>  <p>Short stretcher</p>	<p><b>#6</b> 1pc</p>  <p>Left stretcher</p>	<p><b>#7</b> 1pc</p>  <p>Right stretcher</p>	<p><b>#8</b> 1pc</p>  <p>Top Frame</p>
<p><b>#9</b> 1pc</p>  <p>Glass top</p>			

## HARDWARE

<p><b>#A</b> 8pcs</p>  <p>Bolt <math>\varnothing</math> 3/16"X3/8"</p>	<p><b>#B</b> 8pcs</p>  <p>Bolt <math>\varnothing</math> 1/4"X1/2"</p>	<p><b>#C</b> 5pcs</p>  <p>Glass pad</p>	<p><b>#D</b> 1pc</p>  <p>Allen Wrench 1/4"</p>
<p><b>#E</b> 1pc</p>  <p>Allen Wrench 3/8"</p>			

# ASSEMBLY INSTRUCTIONS

1

- Part #1 x1pc
- Part #2 x1pc
- Part #4 x1pc
- Part #5 x1pc
- Part #6 x1pc
- Part #7 x1pc
- Hardware #A x5pcs

Apply the stretchers (#4,5,6,7) onto the designated slots along the front panel (#1) and left panel (#2). Use image for reference. Insert a bolt (#A) into each end and secure using the Allen wrench (#E).

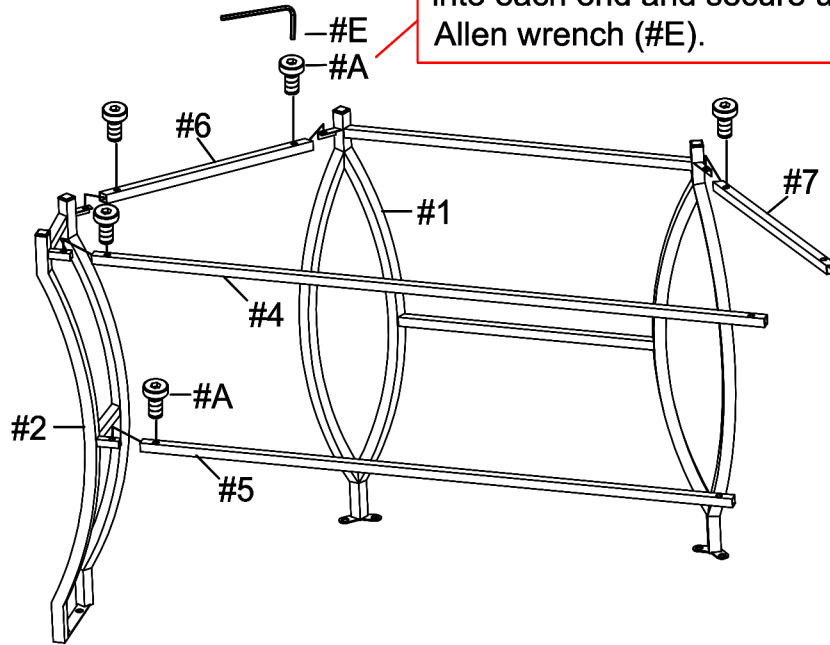

Note: Left and right is determined by facing the front of the assembly in its upright position.

2

- Part #3 x1pc
- Hardware #A x3pcs

Align the right panel (#3) to the stretcher ends, then insert a bolt (#A) into each end. Secure using the Allen wrench (#E).

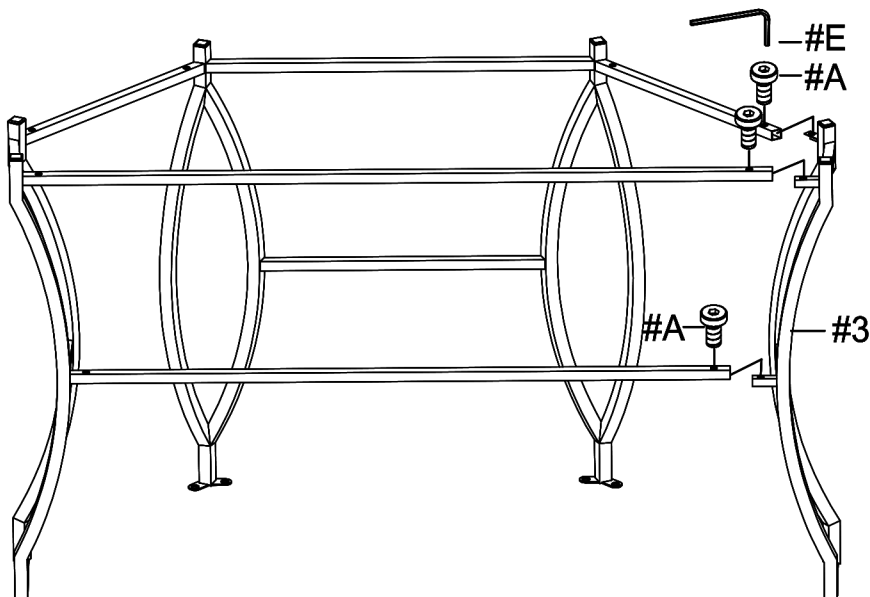

# ASSEMBLY INSTRUCTIONS

## 3

Part (#8) x1pc

Hardware (#B) x8pcs

Place the top frame (#8) face down onto a protected surface, then align the top of the panels to the holes. Insert a bolt (#B) into each hole and secure using the Allen wrench (#D).

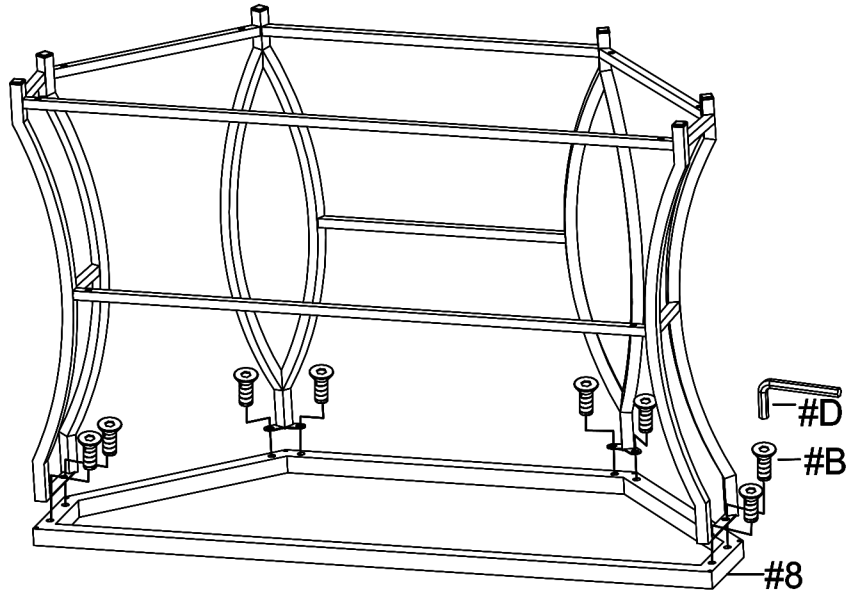

## 4

Part (#9) x1pc

Hardware (#C) x5pcs

Turn the frame upright. Place the glass pads (#C) onto the top frame (#8), then carefully apply the glass top (#9) onto those glass pads.

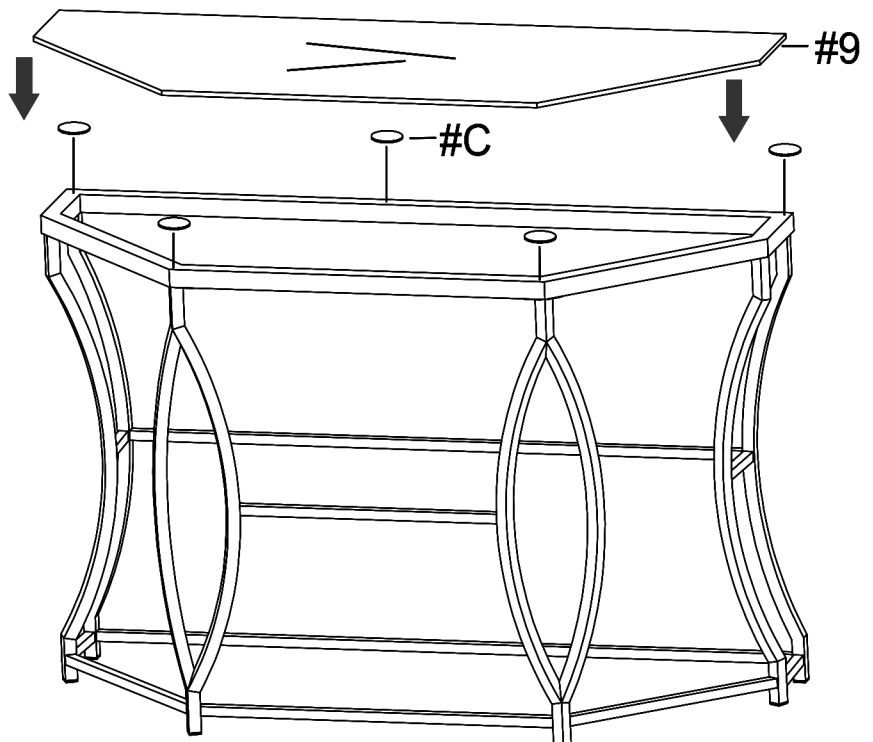

### ASSEMBLY COMPLETED



Please ensure the furniture rests on an even and flat surface. If the product wobbles or feels loose, double-check all bolts and/or screws are properly tightened and secured.

#### ✓ Keep this handy!

Please retain this instruction manual and any order-related information for future reference.

#### ✓ Lift, don't drag!

To avoid damage to product please always LIFT the product when transporting or adjusting the placement.