

**VANITY SET**  
**ENSEMBLE DE COIFFEUSE**  
**JUEGO DE TOCADOR**

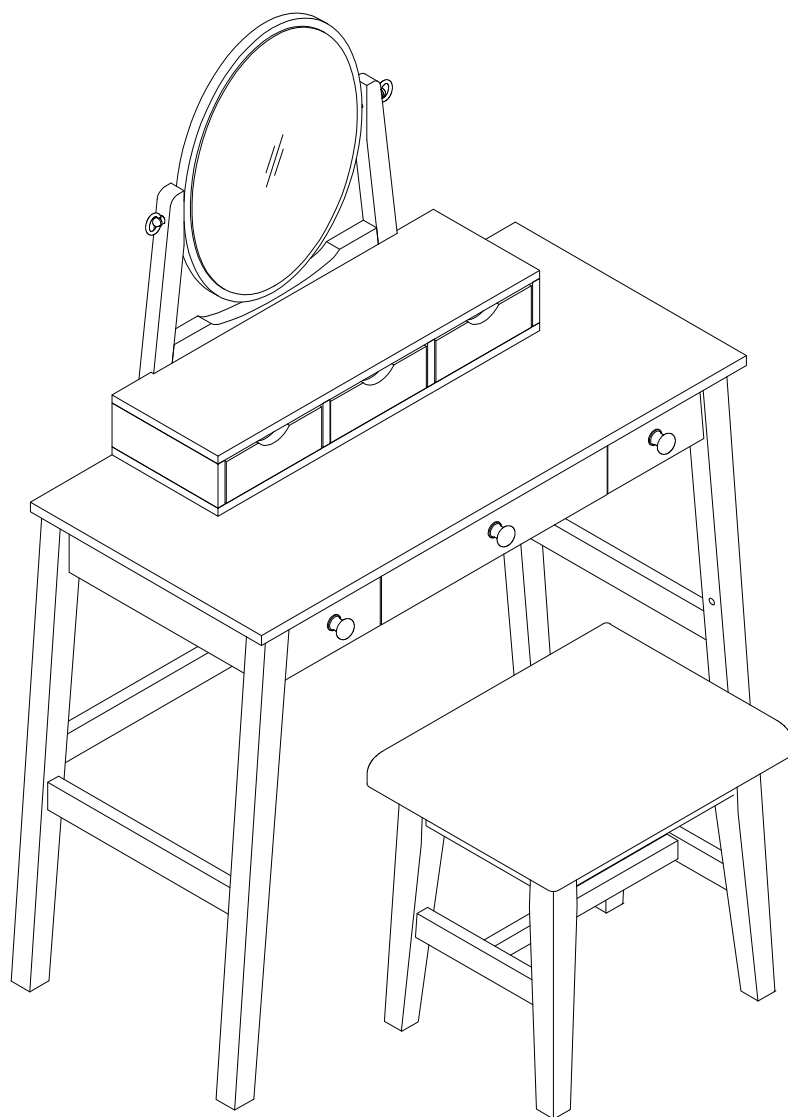

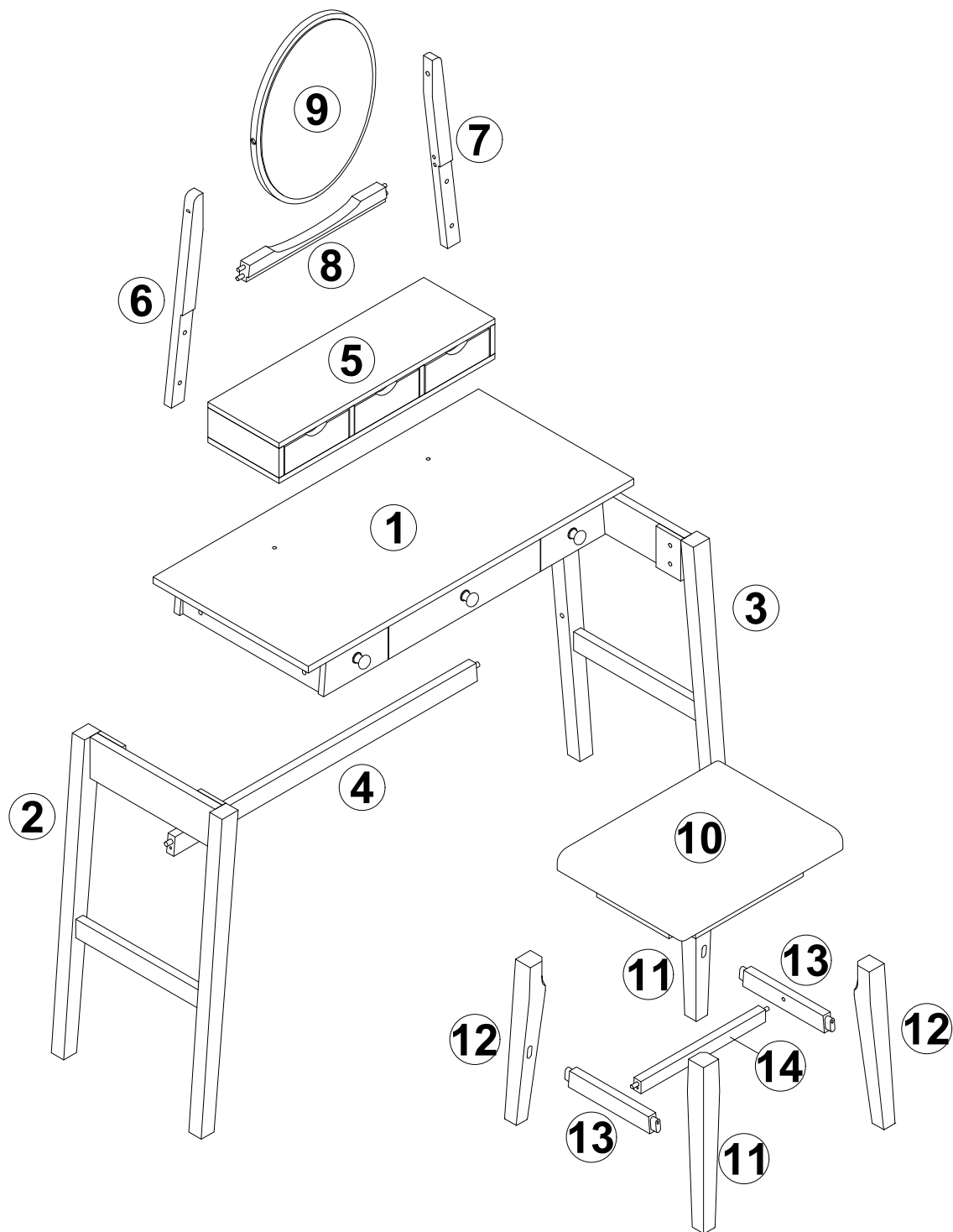







**Parts list / Liste des pièces / Lista de piezas**

01	Table top / Table - dessus / Mesa - encimera	<b>1</b>
02	Left leg frame / Châssis de pied gauche/ Armazón de pata izquierda	<b>1</b>
03	Right leg frame / Châssis de pied droit / Armazón de pata derecha	<b>1</b>
04	Crossbar / Barre transversale / Barra transversal	<b>1</b>
05	Drawer - storage / Tiroir - rangement / Cajón - almacén	<b>1</b>
06	Mirror - left post / Miroir - pied gauche / Espejo - pata izquierda	<b>1</b>
07	Mirror - right post / Miroir - pied droit / Espejo - pata derecha	<b>1</b>
08	Mirror base support / Miroir - support de la base / Espejo - soporte de la base	<b>1</b>
09	Mirror - oval frame / Miroir - châssis oval/ Espejo - armazón oval	<b>1</b>
10	Stool - cushion frame / Tabouret - Châssis du coussin / Taburete - armazón del cojín	<b>1</b>
11	Stool - left side leg / Tabouret - pied latérale gauche / Taburete - pata lateral izquierda	<b>2</b>
12	Stool - right side leg / Tabouret - pied latérale droite / Taburete - pata lateral derecha	<b>2</b>
13	Stool - side stretcher / Tabouret - Barre d'appui latérale / Taburete - Barra de apoyo lateral	<b>2</b>
14	Stool - middle stretcher / Tabouret - Barre d'appui du milieu / Taburete - Barra de apoyo intermedia	<b>1</b>
00	Hardware pack / Paquet contenant la quincaillerie / Juego de herramientas	<b>1</b>



### Hardware list / Liste des pièces / Lista de tornillería

<b>A</b>	Short bolt (Ø1/4" x 1-3/8") / Boulon court / Perno corto		<b>12</b>
<b>B</b>	Long bolt (Ø1/4" x 2-1/4") / Boulon long / Perno largo		<b>08</b>
<b>C</b>	Spring washer (1/4") / Rondelle à ressort / Arandela elástica		<b>20</b>
<b>D</b>	Flat washer (1/4") / Rondelle plate / Arandela plana		<b>20</b>
<b>E</b>	Wood dowel (Ø8 x 3/4") / Goujon en bois / Tarugo de madera		<b>02</b>
<b>F</b>	Bolt (Ø5/16") / Boulon / Perno		<b>02</b>
<b>G</b>	Long screw (Ø4 x 1-3/4") / Vis long / Tornillo largo		<b>06</b>
<b>H</b>	Short screw (Ø4 x 1-3/16") / Vis court / Tornillo corto		<b>02</b>

### Tools required / Outils requis / Herramientas requeridas

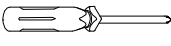
<b>I</b>	<b>Allen key / Clé hexagonale / Llave allen</b>		<b>Supplied / Fourni / Incluido</b>
	<b>Philip screwdriver / Tournevis philip / Destornillador estándar</b>		<b>Not supplied / Non fourni / No incluido</b>

#### IMPORTANT:

1. Do not tighten bolts completely until all bolts are completely lined up and inserted into holes / nuts.
2. Do not over tighten screws and bolts to avoid stripping.
3. Please use hand tools to assemble this product. Do not use power tools.
4. For your safety, assembly by two people is recommended.

#### IMPORTANT:





1. Ne serrez pas complètement les boulons jusqu'à ce que tous les boulons soient complètement alignés et insérés dans les trous / écrous.
2. Ne pas trop serrer les vis et les boulons pour éviter le décapage.
3. Utilisez des outils à main pour assembler ce produit. N'utilisez pas d'outils électriques.
4. Pour raisons de sécurité, l'assemblage devrait être fait par deux personnes.

#### IMPORTANTE:

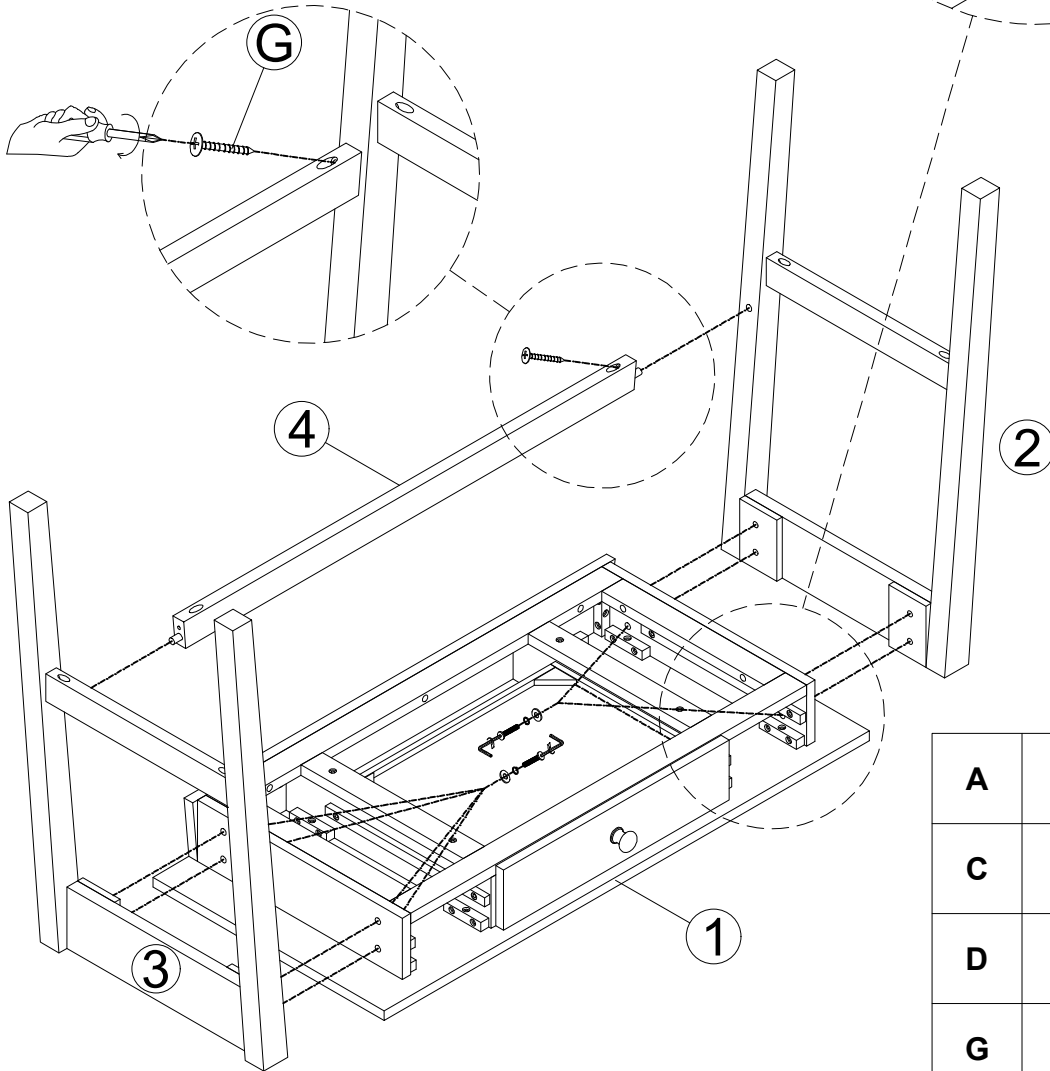
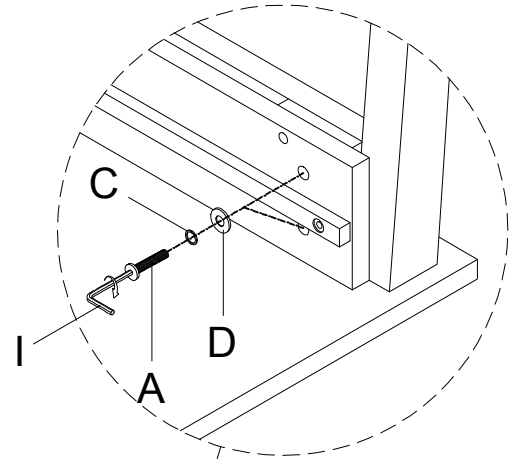
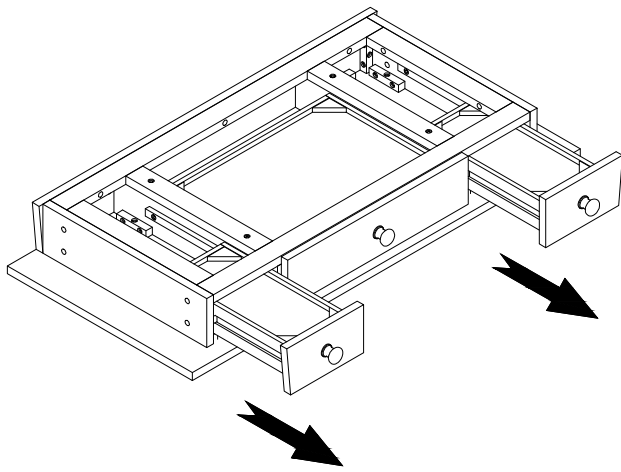
1. No apriete completamente los pernos hasta que todos los tornillos estén alineados completamente y se inserten en los agujeros / tuercas.
2. No apriete demasiado los tornillos y los pernos para evitar que se pelen.
3. Utilice herramientas de mano para montar este producto. No utilice herramientas eléctricas.
4. Por razones de seguridad, el ensamblaje debería efectuarse por dos personas.

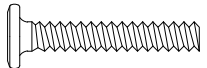
**NOTE:** Lift up the stopper to take side drawer out of the box  
**REMARQUE:** Soulevez le bouchon pour retirer le tiroir de la boîte  
**NOTA:** Levante el tapón para sacar el cajón de la caja





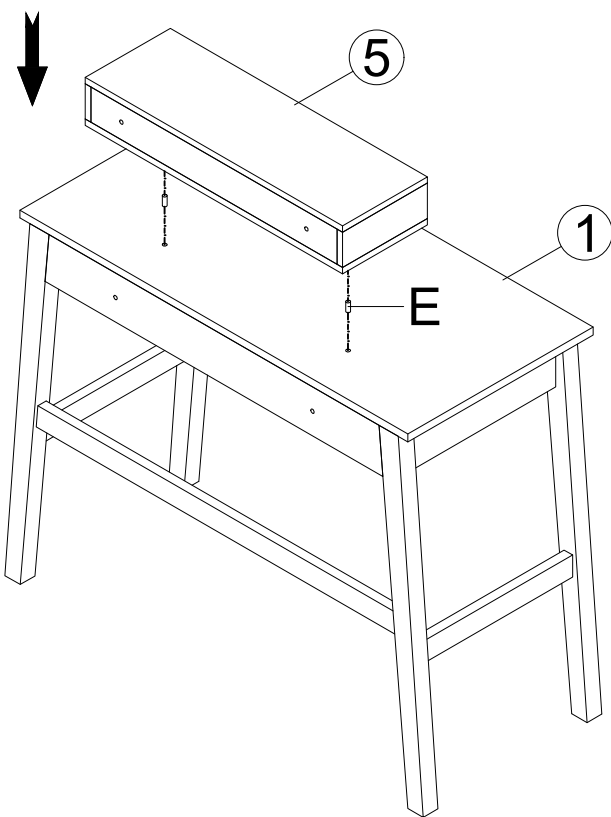

A		8
C		8
D		8
G		2
I		1

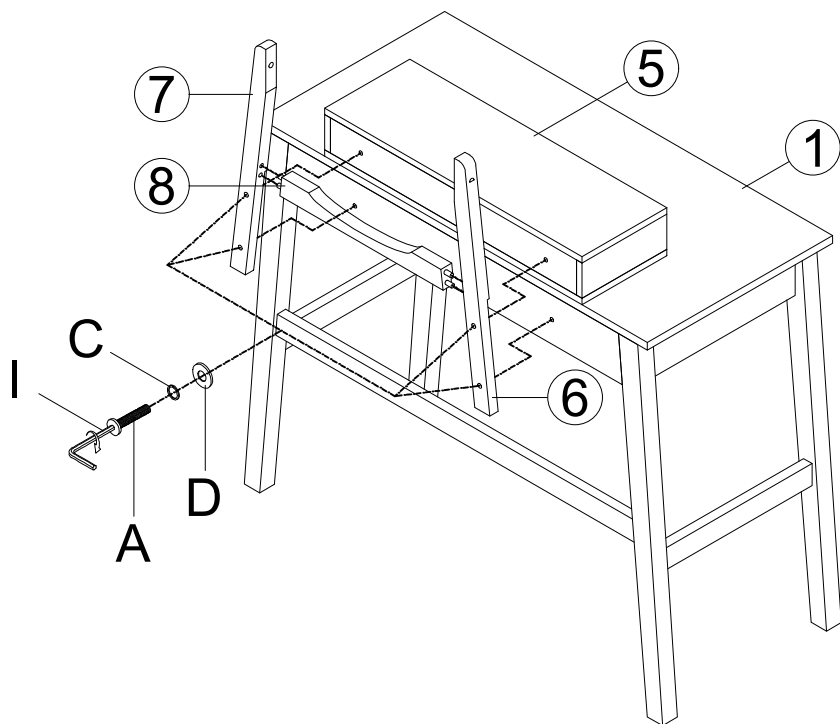

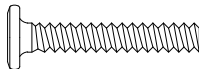
<b>E</b>		<b>2</b>
----------	---	----------





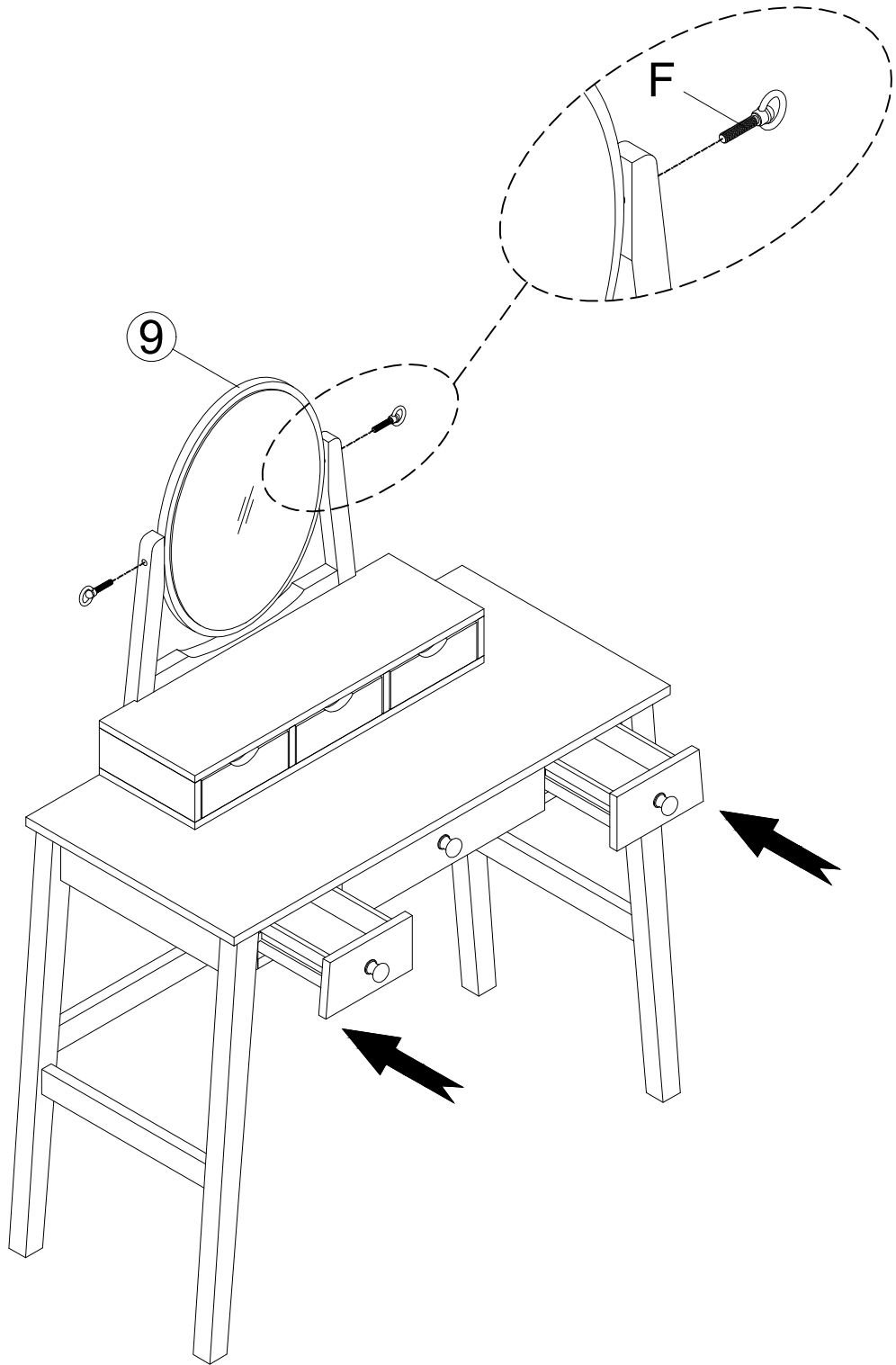

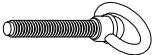

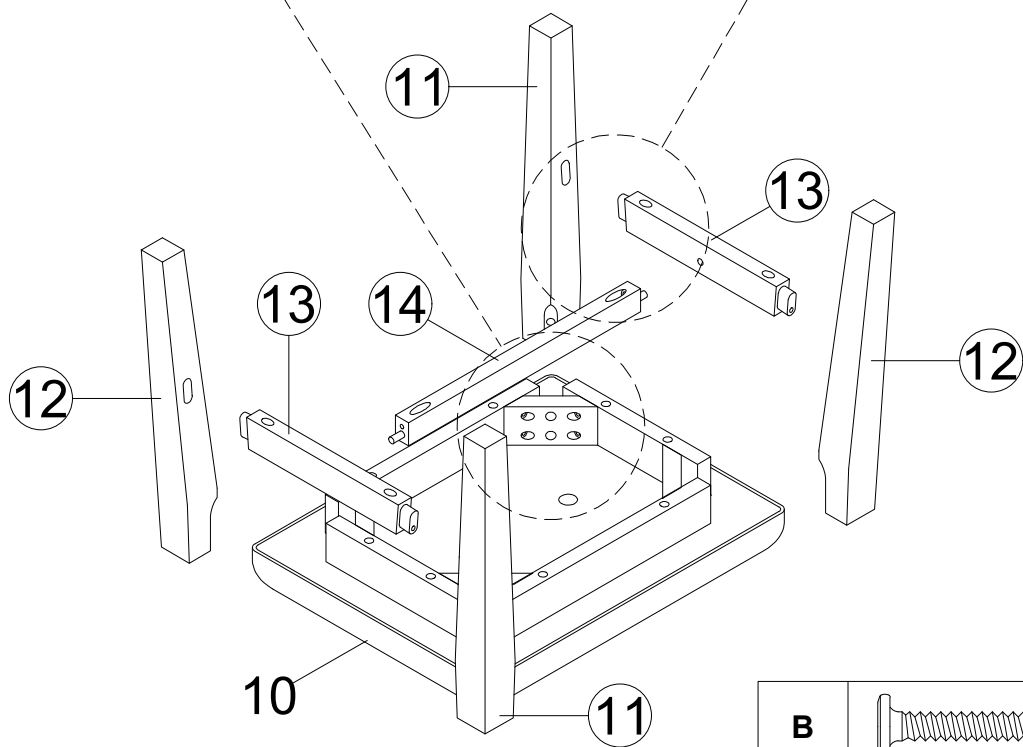
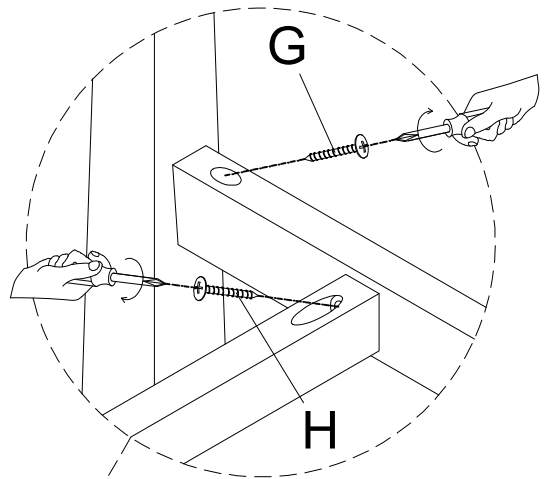
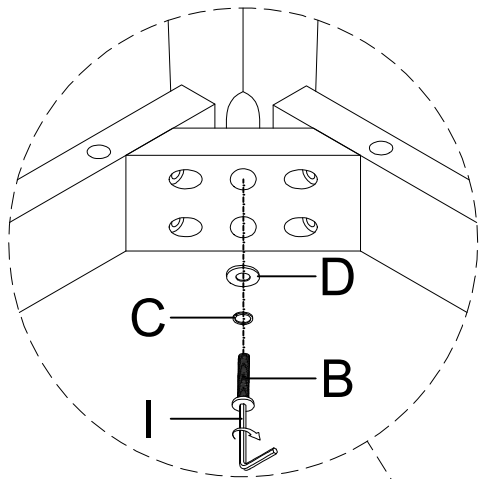
<b>A</b>		<b>4</b>
<b>C</b>		<b>4</b>
<b>D</b>		<b>4</b>
<b>I</b>		<b>1</b>



<b>F</b>		<b>2</b>
----------	---	----------



<b>B</b>		<b>8</b>
<b>C</b>		<b>8</b>
<b>D</b>		<b>8</b>
<b>G</b>		<b>4</b>
<b>H</b>		<b>2</b>
<b>I</b>		<b>1</b>



**ASSEMBLY COMPLETED  
ASSEMBLAGE TERMINÉ  
ENSAMBLAJE TERMINADO**

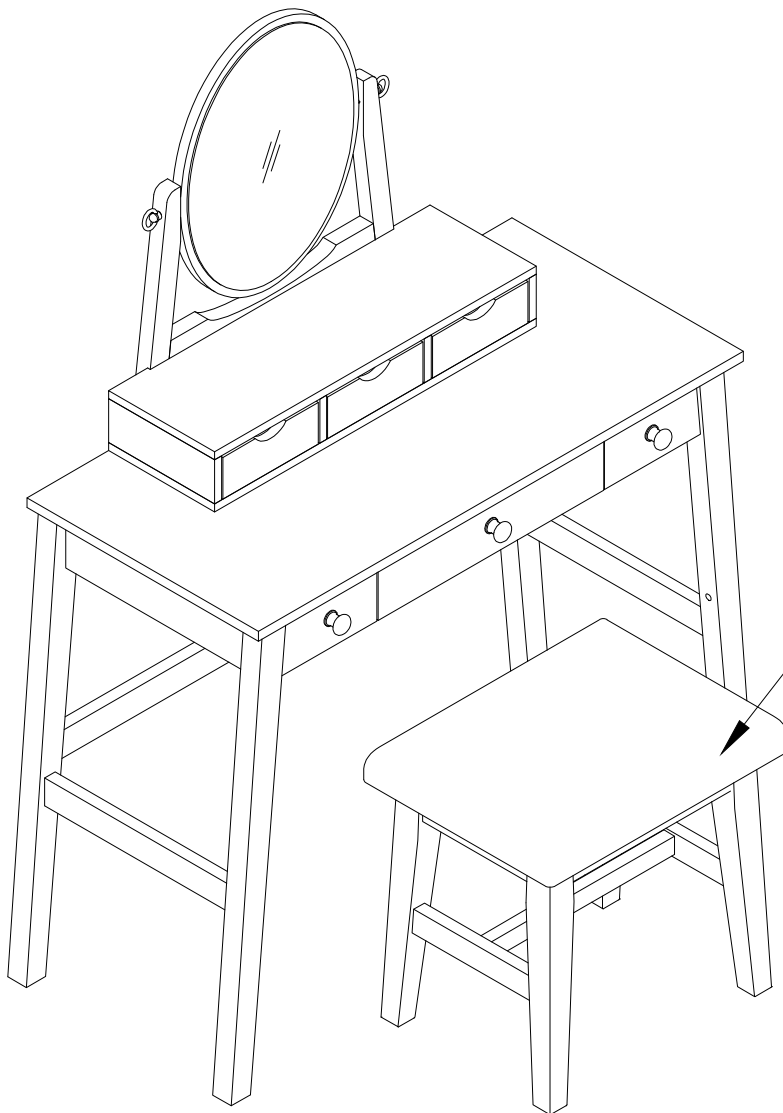

**WEIGHT LIMITS 275LBS  
POIDS MAXIMAL 275LBS  
LÍMITE DE PESO 275LBS**



# **LIMITED 6 MONTHS WARRANTY**

## **GARANTIE LIMITÉE DE 6 MOIS**

### **GARANTÍA LIMITADA DE 6 MESES**

#### **WHAT IS COVERED**

This product is covered under a 6 month limited warranty offered by the manufacturer. To ensure your complete satisfaction, this guarantees the original purchaser that the product supplied is free from defects in materials and workmanship from the date of purchase, under conditions of normal use and care. adequate, valid for six months from the date of purchase. Upfront replacement of missing or defective parts will be sent, free of charge, for a period of 30 days from the date of purchase with valid proof of purchase provided the parts are available in our warehouse and the item purchased is part of our current inventory.

#### **WHAT IS NOT COVERED**

It remains the customer's responsibility for freight and packaging charges to and from the customer service center. Labor and material charges to remove or replace parts under this warranty are not covered.

This warranty does not cover: Furniture used for commercial purposes, failures caused by improper installation assembly or by improper care, unreasonable or abusive use, freeze damage, acts of God, rust, purchased parts or return freight and packaging charges. Proof of purchase ( dated register receipt) is required for this warranty claims.

#### **QU'EST-CE QUI EST COUVERT**

Ce produit est couvert sous une garantie limitée de 6 mois offerte par le fabricant. Afin d'assurer votre entière satisfaction, cela garantit à l'acheteur original que le produit fourni est exempt de défauts de matériaux et de fabrication à compter de la date d'achat, et ce, sous des conditions d'utilisation normales et de soins adéquats, valide pendant six mois après la date d'achat.

Le remplacement de pièces manquantes ou défectueuses dès le départ sera envoyé, sans frais, pour une période de 30 jours suivant la date d'achat avec une preuve d'achat valide pourvu que les pièces soient disponibles dans notre entrepôt et que l'article acheté fait partie de notre inventaire actuel.

#### **QU'EST-CE QUI N'EST PAS COUVERT**

Il y a de la responsabilité du client de ouvrir les frais de transport et d'emballage vers et à partir du centre de service après-vente. Les frais de la main-d'oeuvre et des matériaux pour retirer les pièces ou les remplacer sous cette garantie ne sont pas couverts.

Cette garantie ne couvre pas: les meubles utilisés à des fins commerciales, les défaillances causées par un mauvais assemblage ou entretien( sans dépasser les limites de poids). l'utilisation déraisonnable ou abusive, les dommages causés par le gel, la rouille, les frais de transport et d'emballage pour des pièces achetées ou retournées. Une preuve d'achat( reçu de caisse daté) est requise pour les réclamations sous garantie.

#### **QUÉ ESTÁ CUBIERTO**

Este producto está cubierto por la garantía limitada de 6 meses de nuestro fabricante. Para asegurar su total satisfacción, ésta garantiza al comprador original que el artículo proporcionado se encuentra libre de defectos materiales y de fabricación, a partir de la fecha de compra, y que permanecerá en tal estado, sometido a un uso normal y cuidados adecuados, durante los seis meses posteriores a la fecha de la compra.

Las partes faltantes o que presenten defectos al inicio de ese período de tiempo serán enviadas sin cargo, durante un lapso de 30 días a partir de la fecha de compra, mediante la presentación de un comprobante de compra válido, siempre que las partes estén disponibles en nuestro almacén y el artículo adquirido sea parte de nuestro inventario actual.

#### **QUE' NO ESTÁ CUBIERTO**

El cliente asumirá los costos de flete y empaque hacia y desde el centro de servicio de cliente. Los cargos de material y mano de obra para extraer o reemplazar partes en el marco de la ganrantía no están cubiertas.

Esta garantía no cubre: muebles utilizados con fines comerciales, fallas causadas por montaje de instalación inadecuados o uso indebido( se recomienda no exceder los límites de peso), uso no razonable o abusivo, daños por congelación, oxidación, partes compradas, flete de devolución y cargos de empaque. Se exigirá el comprobante de compra( la factura de registro con fecha) para hacer valer la garantía.

⚠ WARNING		⚠ AVERTISSEMENT		⚠ ADVERTENCIA	
	<p>Children have died from furniture tipover. To reduce the risk of furniture tipover:</p> <ul style="list-style-type: none"> <li>•ALWAYS install tipover restraint provided.</li> <li>•NEVER put a TV on this product.</li> <li>•NEVER allow children to stand, climb or hang on drawers, doors, or shelves.</li> </ul>		<p>Des enfants sont morts quand un meuble s'est renversé sur eux. Pour prévenir le basculement du meuble:</p> <ul style="list-style-type: none"> <li>•Installez TOUJOURS le dispositif fourni pour prévenir le basculement.</li> <li>•Ne placez JAMAIS un téléviseur sur ce produit.</li> <li>•Ne laissez JAMAIS un enfant se tenir debout ou monter sur un tiroir, une porte ou une tablette, ni s'y accrocher.</li> <li>•N'ouvrez JAMAIS plus d'un tiroir à la fois.</li> <li>•Placez les objets les plus lourds dans les tiroirs les plus bas.</li> </ul>		<p>Un mueble que se vuelca puede provocar la muerte de un niño. Para reducir el riesgo de volcadura del mueble:</p> <ul style="list-style-type: none"> <li>•Instale SIEMPRE los dispositivos antivuelco proporcionados.</li> <li>•NUNCA coloque un televisor sobre este mueble.</li> <li>•NUNCA permita que un niño suba sobre un cajón, una puerta o un estante ni que se cuelgue de dichas piezas.</li> <li>•NUNCA abra más de un cajón a la vez.</li> <li>•Guarde los artículos más pesados en los cajones inferiores.</li> </ul>
	<ul style="list-style-type: none"> <li>•NEVER open more than one drawer at a time.</li> <li>•Place heaviest items in the lowest drawers.</li> </ul> <p><i>This is a permanent label. Do not remove!</i></p>		<ul style="list-style-type: none"> <li>•N'ouvrez JAMAIS plus d'un tiroir à la fois.</li> <li>•Placez les objets les plus lourds dans les tiroirs les plus bas.</li> </ul> <p><i>Cette étiquette est permanente. Ne l'enlever pas!</i></p>		<ul style="list-style-type: none"> <li>•NUNCA abra más de un cajón a la vez.</li> <li>•Guarde los artículos más pesados en los cajones inferiores.</li> </ul> <p><i>Esta etiqueta es permanente. No la quite!</i></p>

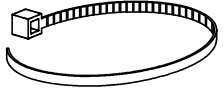
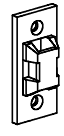
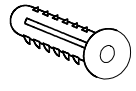
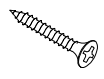
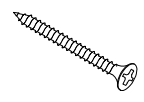
				
Strap A (1pc)	Mounting Bracket B (2pcs)	Wall Anchor C (2pcs)	Short Screw Ø3.5X15mm D (2pcs)	Long Screw Ø4X38mm E (2pcs)
Sangle A (1pc)	Support de fixation B (2pcs)	Ancrage mural C (2pcs)	Vis courte D (2pcs)	Vis longue E (2pcs)
Correa A (1pz)	Soporte de montaje B (2pzs)	Anclaje mural C (2pzs)	Tornillo corto D (2pzs)	Tornillo largo E (2pzs)

Step 1: Put wall anchor (C) into the wall and attach mounting bracket (B) to the wall with long screw (E).

Étape 1 : Insérez les ancrages muraux (C) dans le mur et fixez le support de fixation (B) au mur avec une vis longue (E).

Paso 1: Coloque los anclajes murales (C) en la pared y sujete el soporte de montaje (B) en la pared con un tornillo largo (E).

**PLEASE NOTE: For your safety, to prevent the danger of this unit tipping over, it is important that the wall anchors are properly attached.**

**VEUILLEZ NOTER QUE: Pour votre sécurité, afin de prévenir le basculement du meuble, il est important que les ancrages muraux soient correctement fixés.**

**TOME EN CUENTA QUE: Por su seguridad, con el fin de disminuir el riesgo de caída del mueble, es importante que los anclajes estén correctamente instalados.**

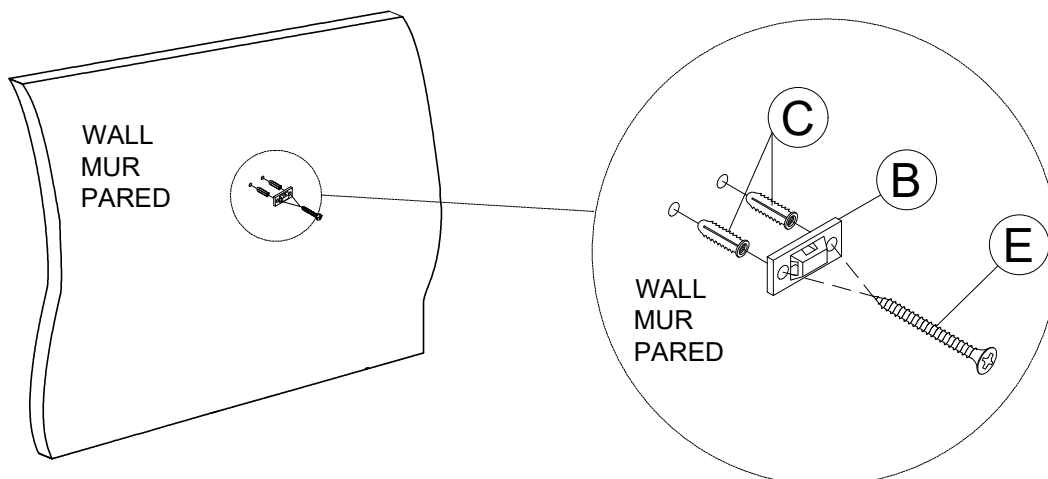

Step 2: Attach mounting bracket (B) to the back of the vanity with short screw (D).

Étape 2 : Fixez le support de fixation (B) au dos du produit avec une vis courte (D).

Paso 2 : Coloque el soporte de montaje (B) en el reverso del producto con un tornillo corto (D).

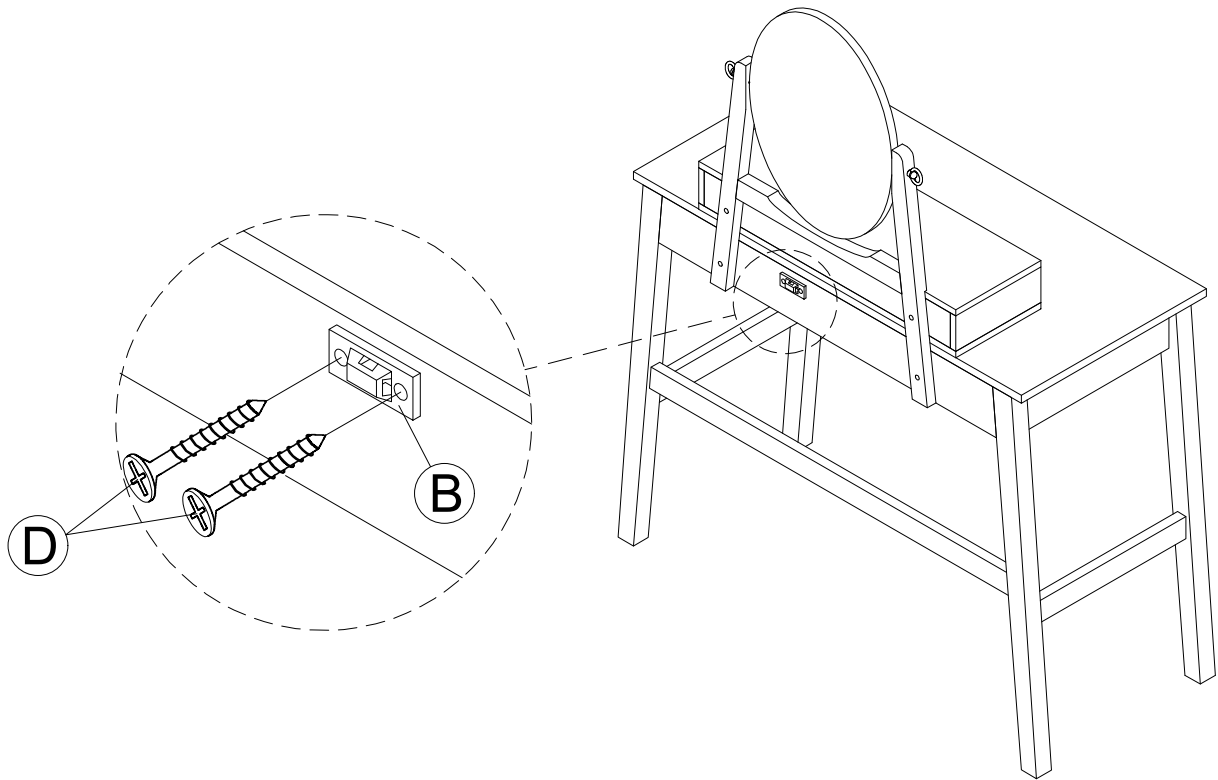

Step 3: Slide the strap (A) through the mounting brackets and pull to tighten the vanity snug against the wall.

Étape 3 : Glissez la sangle (A) dans les supports de fixation et tirez pour bien ajuster le produit contre le mur.

Paso 3: Deslice la correa (A) a través de los soportes de fijación y estire para apretar bien el librero contra la pared.

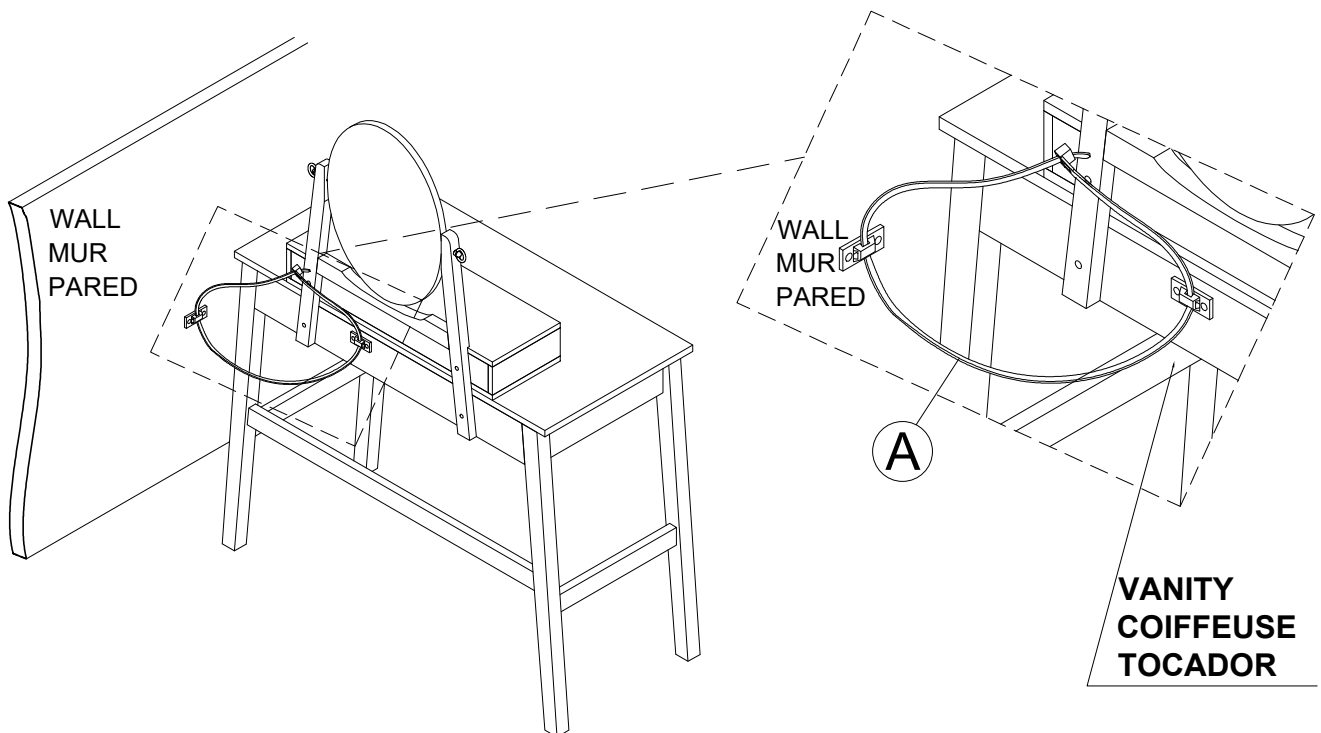

**ASSEMBLY COMPLETED**  
**ASSEMBLAGE TERMINÉ**  
**ENSAMBLAJE TERMINADO**

