

# INSTALLATION INSTRUCTIONS

DeerValley®

---

## Medicine Cabinet

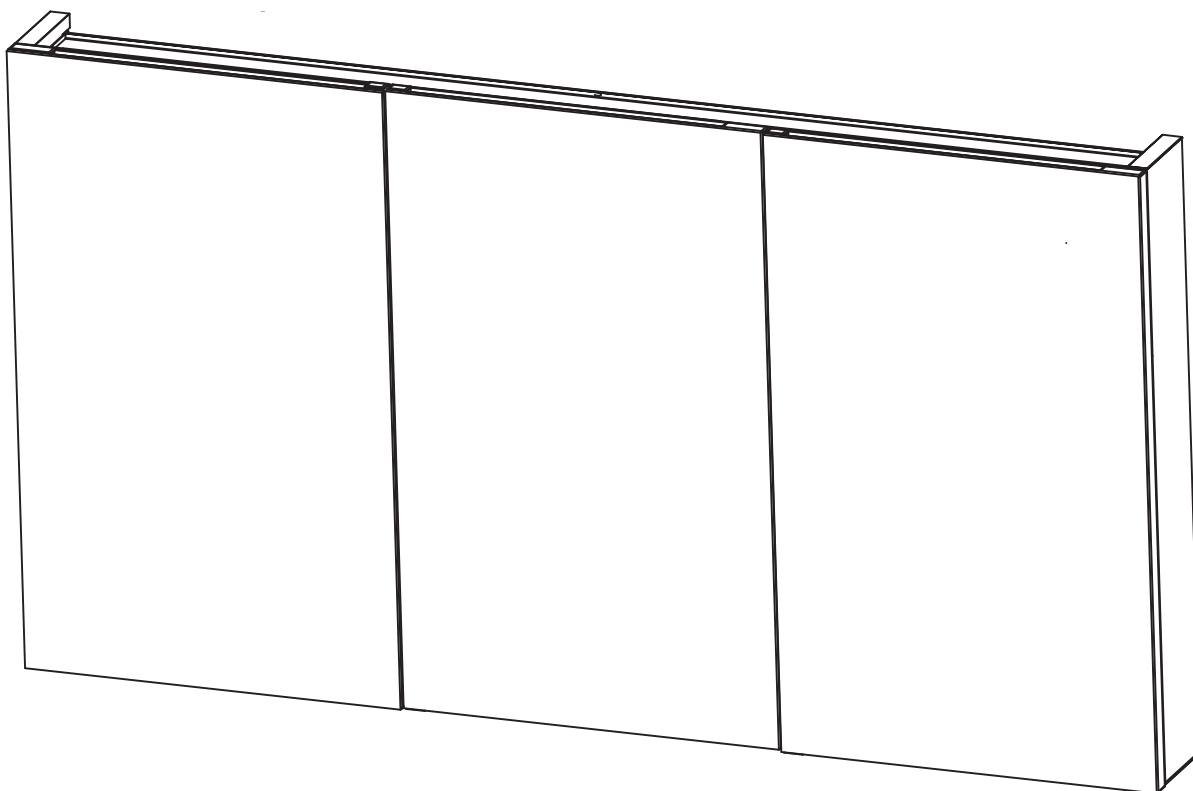











### BEFORE INSTALLATION

- Please read these instructions carefully to familiarize yourself with the required tools, materials, and installation procedures. Follow only the sections that apply to your specific installation. This will help prevent costly mistakes. In addition to proper installation, read and follow all operating and safety instructions.
- These instructions contain important care, cleaning, and warranty information. Please retain this document after installation.
- Before installation, carefully inspect the product for any signs of damage.
- Before drilling, check the wall cavity for electrical wiring, plumbing, or other obstructions.
- If repair or replacement is required, it must be performed by qualified service personnel.



#### WARNING:

- Risk of injury or product damage.
- Do not use acidic or alkaline cleaners, or alcohol-based products, to clean the surface. Clean only with a soft, damp cloth.

REQUIRED TOOLS (NOT INCLUDED)					
 Electric drill	 Drill bit (Ø 8 mm / 0.31 in)	 Measuring tape	 Pencil	 Spirit level	
SUPPLIED PARTS (PACKAGE)					
 Wall anchors × 6	 Screws × 6	 Bottom bracket × 1	 Tempered glass shelves × 4	 Laminated glass clips × 8	 Sliding mounting hangers × 3

### INSTALLATION CARE & SAFETY

- Always wear safety goggles when drilling.
- Use power tools with caution.
- Be aware of hidden electrical wires or plumbing pipes.
- Exercise caution when drilling into tile to prevent the drill from slipping.
- Applying a piece of masking tape to the wall before marking the mounting holes will help prevent the drill from wandering.

### IMPORTANT

- DO NOT strike glass components with hard or pointed objects.
- DO NOT place very hot or very cold objects directly on or near glass surfaces unless a sufficiently thick insulation material is used to prevent contact with the glass.
- If the glass becomes chipped or broken, replace it immediately.

### INSTALLATION STEPS – HANGING INSTALLATION

1. Remove the product from the packaging. Take out the sliding mounting hangers and slide them into the cabinet through the rear slots, following the direction shown in the illustration.

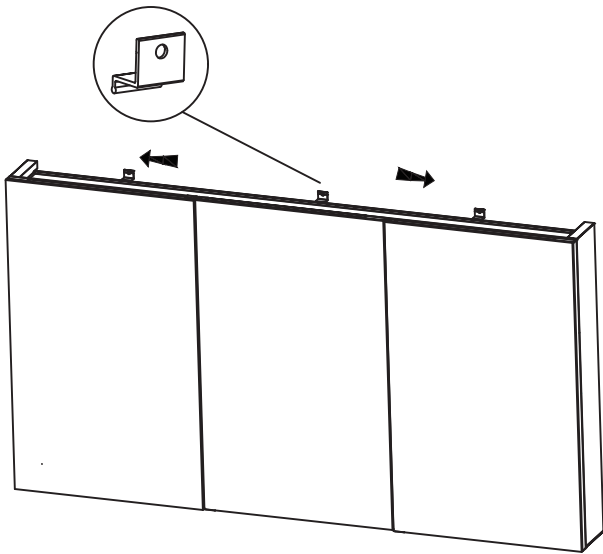

2. As shown in the illustration, install the bottom bracket on the wall by following the steps below:

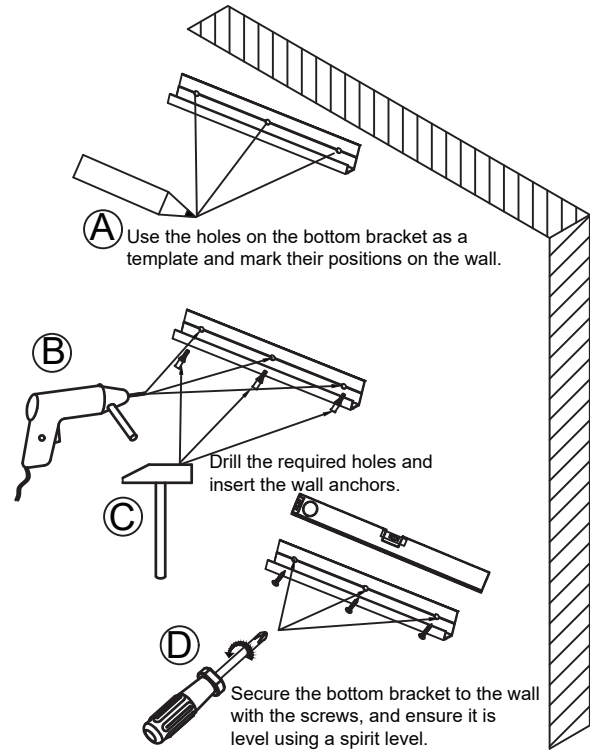

3. Place the cabinet onto the bottom bracket, secure the positioning buckle, and ensure the installation height meets the following requirements.

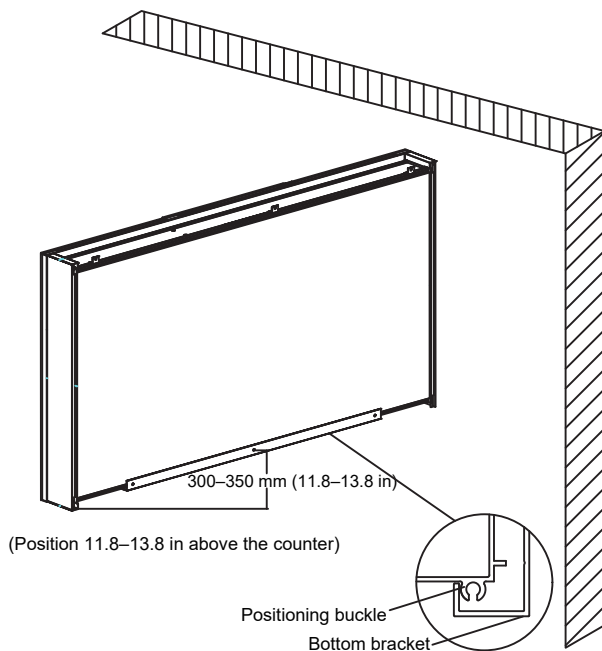

4. Follow the steps shown in Figure 2 to install the sliding mounting hangers.

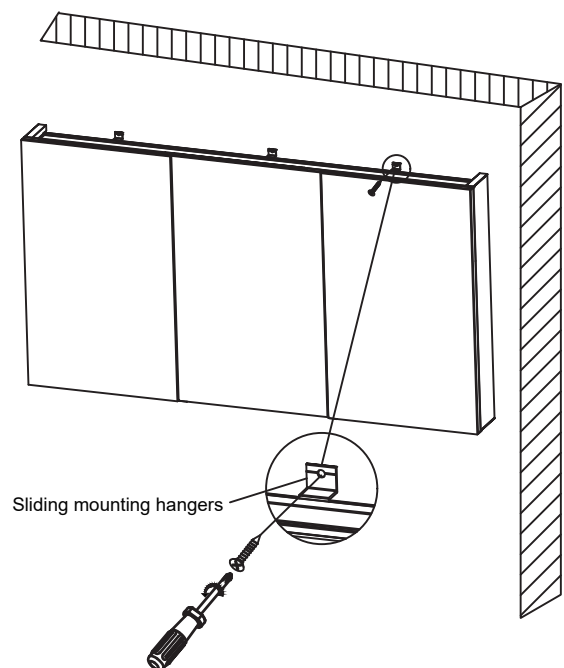

5. Remove the laminated glass clips and tempered glass shelves from the packaging. Install the laminated glass clips on the inside of both sides of the cabinet.

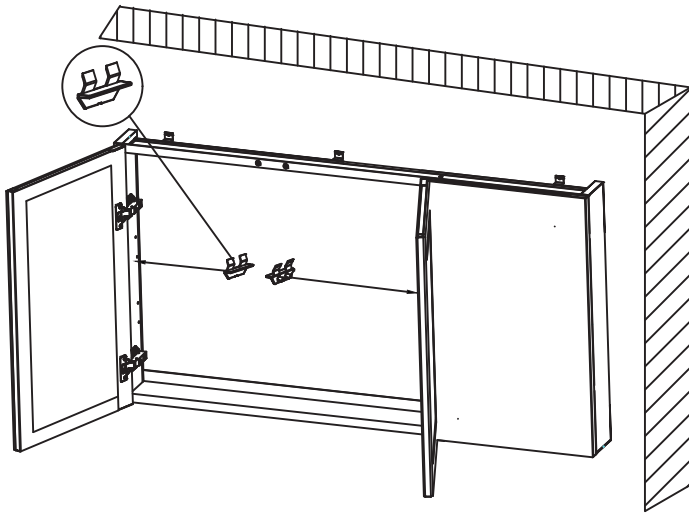

6. After installing the laminated glass clips, place the tempered glass shelves into the clips as shown in Figure A. Once positioned, press down firmly as shown in Figure B to ensure the shelves are securely held.

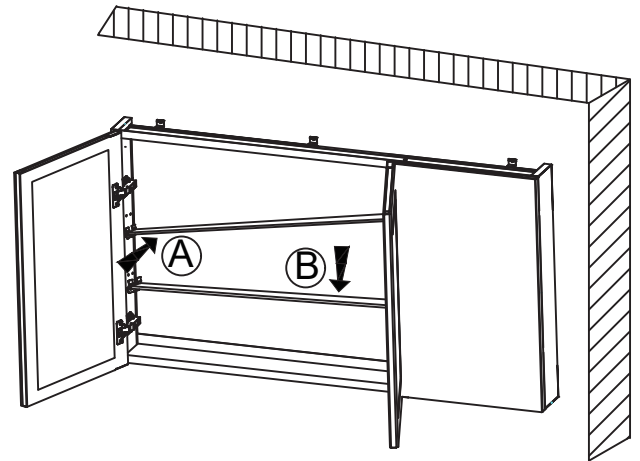

7. Adjust the cabinet door to ensure it opens and closes smoothly.

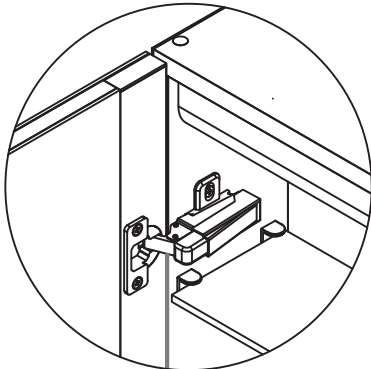

Mirror cabinet door

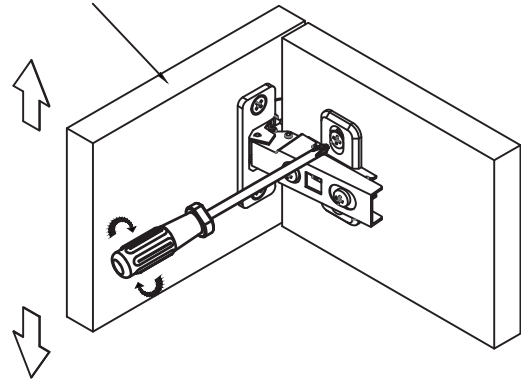

Mirror cabinet door

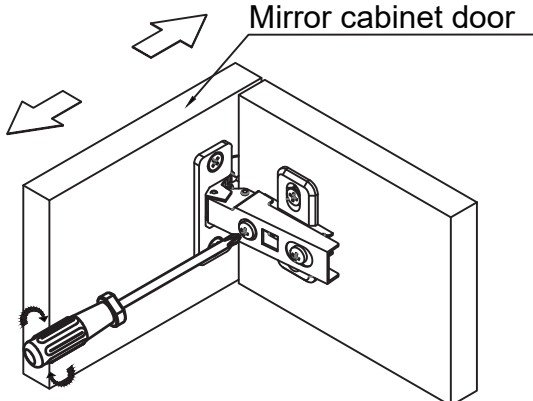

Mirror cabinet door

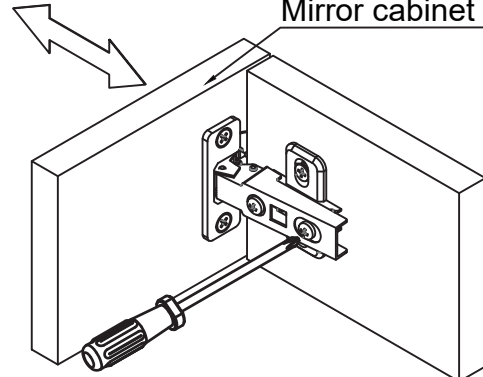

## LIMITED WARRANTY COVERAGE

### 1-YEAR LIMITED WARRANTY

DeerValley products are made with quality materials and excellent craftsmanship to provide customers with a long-lasting product. If any defects in materials or craftsmanship are found under normal use within the first year of delivery, DeerValley will provide replacement parts at no charge or, at its option, replace any product or part of the product deemed defective under normal installation, use, service, and maintenance. This warranty applies only to the original purchaser. Proof of purchase will be required to process any claims. SCRATCHES ARE NOT COVERED UNDER WARRANTY.

The manufacturer warrants that this product will be free from manufacturing defects for the duration of the above-mentioned warranty period. Please retain a copy of the original invoice as proof of purchase.

DeerValley will, at its option, (1) repair or replace the defective part(s) or product(s) at no charge; (2) issue a refund for the original purchase price of the product(s) (valid within 30 days from the date of delivery); or (3) issue a credit to be applied toward the purchase of a new DeerValley product. Shipping/delivery charges may apply and are at DeerValley's sole discretion.

DeerValley recommends that installations be performed by a licensed, professional plumber. DeerValley will not be held responsible for any damage or product failure resulting from improper installation, misuse, or failure to hire a licensed professional. Additionally, DeerValley is not responsible for any removal or installation costs.

This limited warranty does not cover goods that have been subjected to accidents, negligence, improper installation, product abuse, product misuse, or the use of cleaners containing abrasives, alcohol, or other organic solvents. Such exclusions apply regardless of whether the actions were performed by a contractor, service company, or the purchaser.

DeerValley's responsibility under this limited warranty is limited solely to the replacement of parts and does not cover any other costs. DeerValley will not be responsible for labor charges or any damage incurred during installation, repair, or replacement, nor for any indirect, incidental, or consequential damages, losses, injuries, or costs of any kind related to this product. Except as required by law, this limited warranty replaces and excludes all other warranties, conditions, and guarantees, whether expressed or implied, statutory or otherwise, including but not limited to those regarding merchantability or fitness for a particular purpose.

### RESPONSIBILITIES OF OTHERS

It is the responsibility of the installer or building contractor, acting on behalf of the user, to inspect the unit prior to installation. They are responsible for ensuring that the unit is free from defects or damage.

Notices are placed on and within the unit, as well as on the shipping carton, to inform the installer of their responsibility.

If a problem is identified, the unit must not be installed. DeerValley is not responsible for failures or damage that could have been identified, repaired, or prevented through proper inspection and testing prior to installation.

Damage occurring during transit is the responsibility of the carrier. The user or installer must open the crate and inspect the unit for damage upon delivery. If damage is discovered, it must be reported immediately to the seller and the carrier in writing, and an inspection must be requested. If the carrier fails to respond, the issue should be reported to both the seller and the carrier. Freight claims should be filed promptly thereafter.

### LIMITATIONS AND EXCLUSIONS

This warranty does not cover negligence, misuse, abuse, improper installation, carelessness, accidents, hard water or mineral deposits, exposure to corrosive materials, misapplication, damages resulting from improper maintenance, alteration of the product, or failure to follow the care or installation instructions provided with your product. The warranty becomes void if the DeerValley product is altered or if repairs are attempted using unauthorized accessories or parts not provided by DeerValley.

DeerValley is not liable for the loss of use of its products, inconvenience, or any other incidental or consequential costs, expenses, or damages. Please note that some states do not allow the exclusion or limitation of incidental damages.

### DISCLAIMER

Except as expressly stated, no warranties or obligations, whether express, implied, oral, or statutory, are provided. No dealer or other individual has the authority to make any warranties or representations regarding DeerValley or its products. DeerValley shall not be held responsible for any such unauthorized warranties or representations.

### WARRANTY SERVICE

NOTE: When requesting warranty service, please ensure you have the following:

- A copy of the original invoice
- Date of installation
- Description and pictures of the defect
- Model number or product description

To obtain warranty service or replacement parts, contact DeerValley Customer Service. DeerValley will determine whether to repair or replace the product, issue a refund, or provide a credit.