

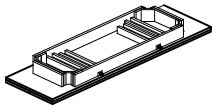

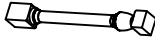







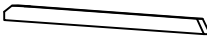

ASSEMBLY INSTRUCTION

CONVERTIBLE TABLE

A Table Top	B Table Leg	C Lower Foot	D Table Stretcher
			
1 pc	4 pcs	2 pcs	1 pc
E Support Rod	F Bolt 5/16"*1-1/2"	G Bolt 5/16"*2"	H Bolt 5/16"*3-1/8"
			
2 pcs	4 pcs	8 pcs	4 pcs
I Lock Washer 5/16"	J Flat Washer 5/16"	K Double Nut 5/16"*3-1/2"	L Nut Stopper 5/16"
			
16 pcs	16 pcs	2 pcs	2 pcs
M Nut 5/16"	N Wrench 1/2"*3-3/8"	O Allen Wrench 4*4"	
			
2 pcs	1 pc	1 pc	

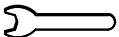

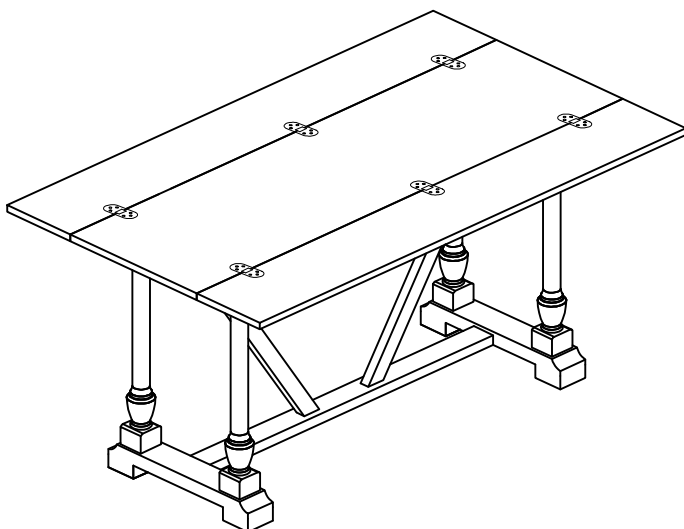
This page lists all the contents included in the box. Please take the time to identify the hardware as well as the individual components to this product. As you unpack and prepare for assembly, place the contents on a carpeted or padded area to protect them from damage.

- 1** Put Table Leg (B) then Flat Washer (J), Lock Washer (I), Bolt (G) and tighten with Allen Wrench (O). Put Support Rod (E) then use Flat Washer (J), Lock Washer (I), Bolt (F) and tighten with Allen Wrench (O).

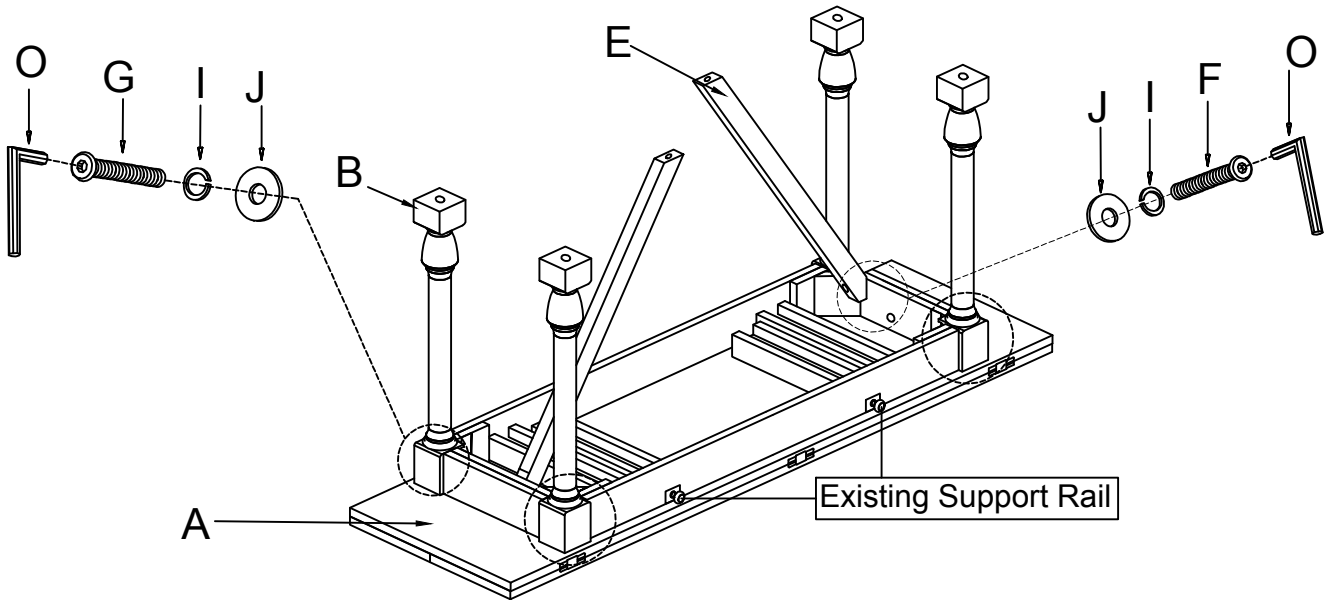

- 2** Attach Lower Foot (C) to Table Stretcher (D), using Double Nut (K), Nut Stopper (L), Nut (M) and Wrench (N).

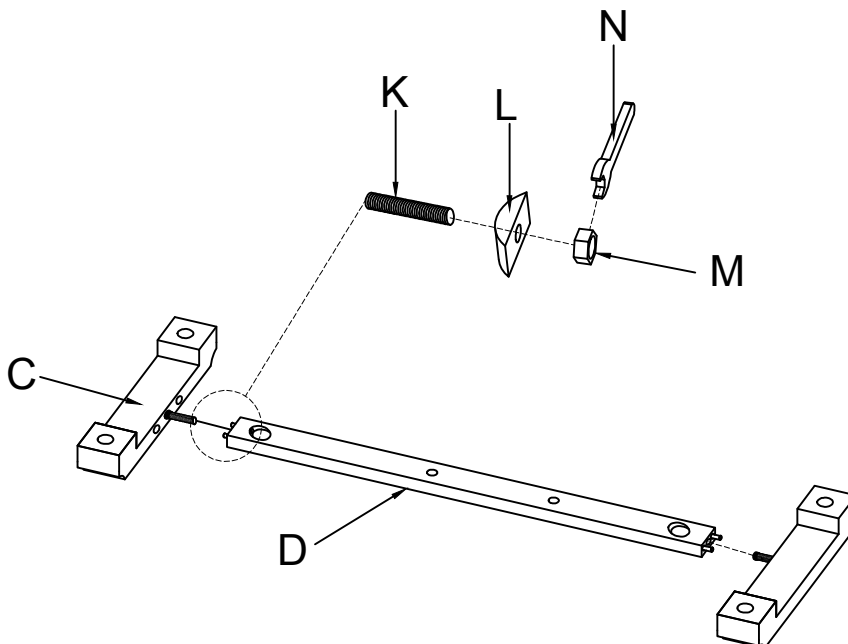

3

Use Flat Washer (J), Lock Washer (I), Bolt (H) and Allen Wrench (O) to tighten at underneath lower foot. After that, use Flat Washer (J), Lock Washer (I), Bolt (F) and Allen Wrench (O) to tighten the Support Rod (E).

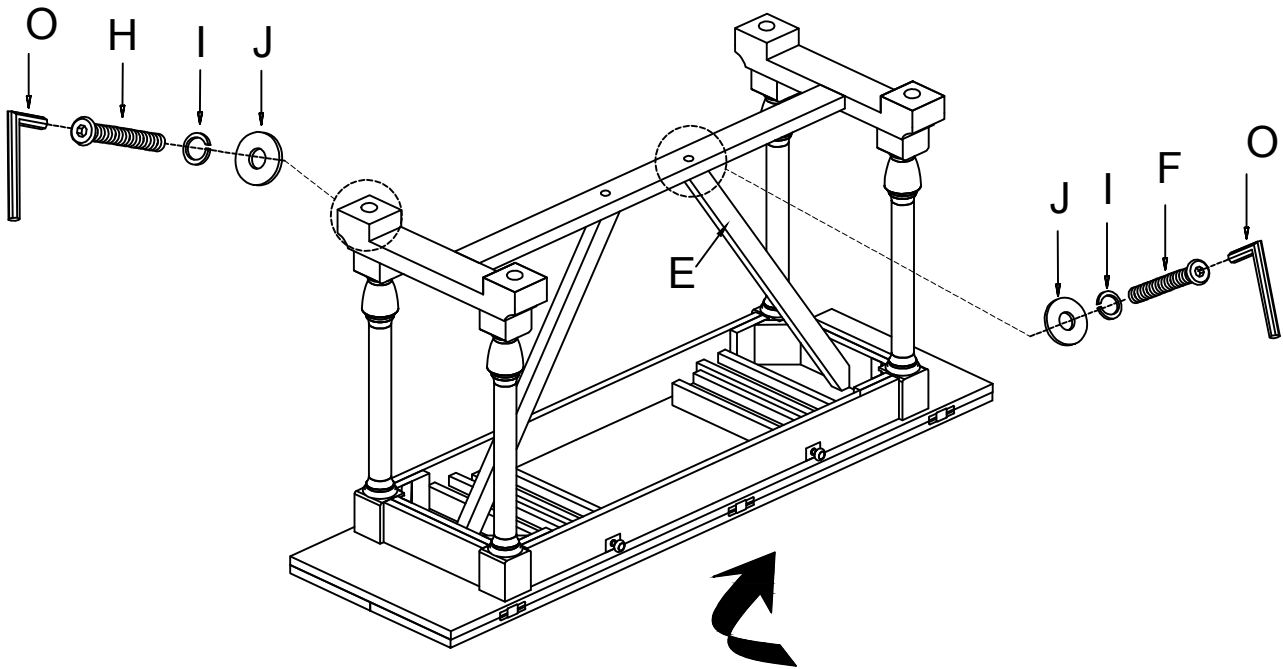
**4**

Assembly is completed.

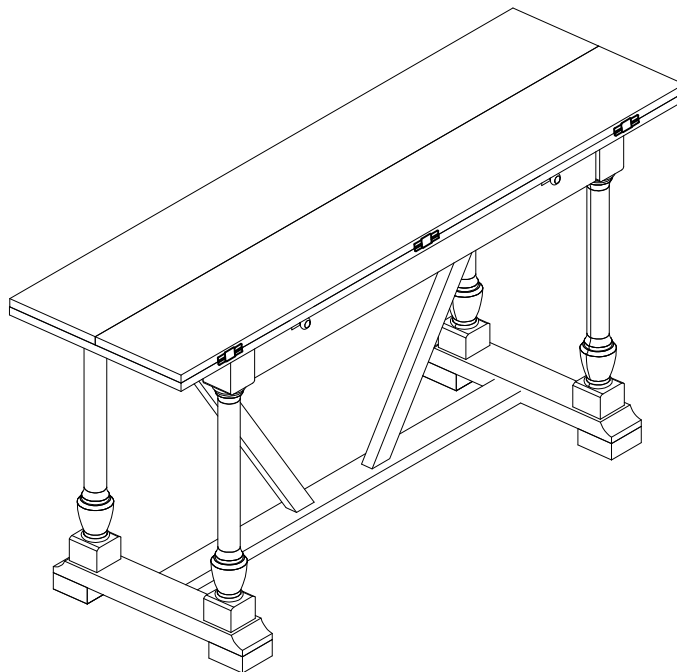

5

Pull Existing Support Rail for the bigger size table top.

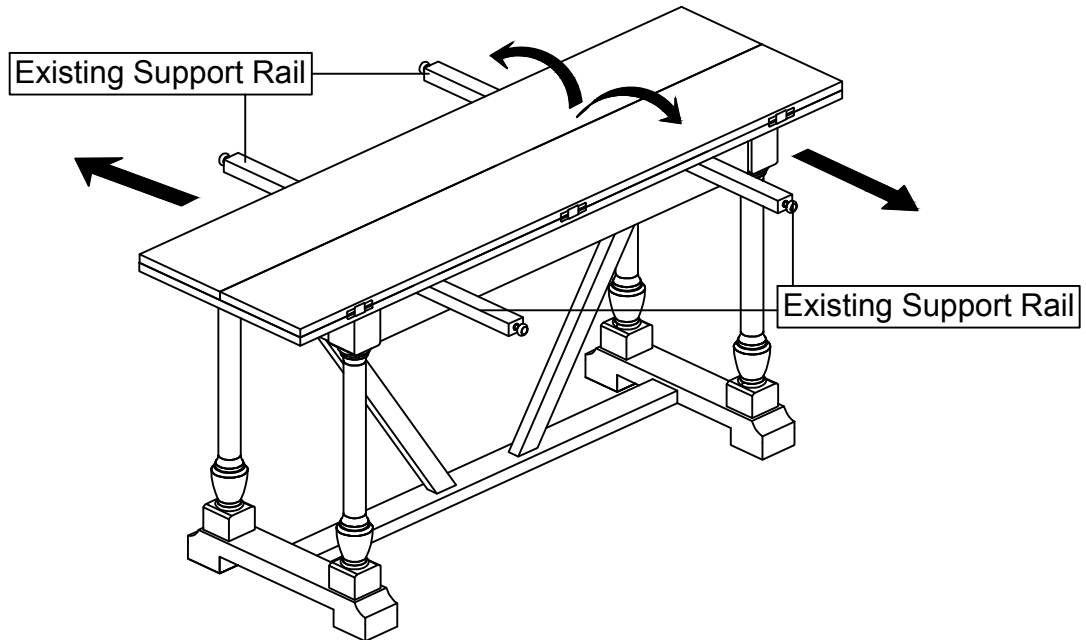

Cleaning & Care

Treat surface with care. Surface is resistant to scratches but is not scratch resistant. Clean surfaces with a dry or damp soft cloth. Do not use abrasive cleaners. Hardware may loosen over time. Periodically check that all connections are tight.