

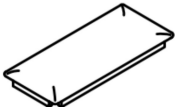







Assembly instructions



Product name: Shoe bench
80cm

NO.	Part name	Parts drawing	Parts Size	Quantity
1	Seat frame		600 * 300 * 63MM	1
2	Movable laminate		530 * 240 * 12MM	2
3	Bottom frame		530 * 240 * 32MM	1
4	Front legs		502 * 40 * 40MM	2
5	Back legs		502 * 40 * 40MM	2
A	Round head hexagonal screws		M6 * 50MM	8
B	Round head hexagon screws		M6 * 35MM	4
C	Flat washers		M6 * 13MM	12

This product has been inspected for wood and paint, and it fully conforms to the national quality inspection standards. After passing the inspection, it will be delivered to the factory. After confirming that the packaging is in good condition, it can be sold.

Product name	Solid wood furniture	Quality
Pualified	Qualified product	QC 02
Level	One level	

NO.	Part name	Parts drawing	Parts Size	Quantity
-----	-----------	---------------	------------	----------

D	Hexagon wrench		M4 * 57MM	1
E	L-Shaped Laminating Brackets		Φ6 * 20 * 16MM	8

Step 1

Step 2

Note: First assemble the front foot No. 4 and back foot No. 5 as shown in the figure, and then connect the bottom plate combination No. 3 with the surrounding foot posts together.

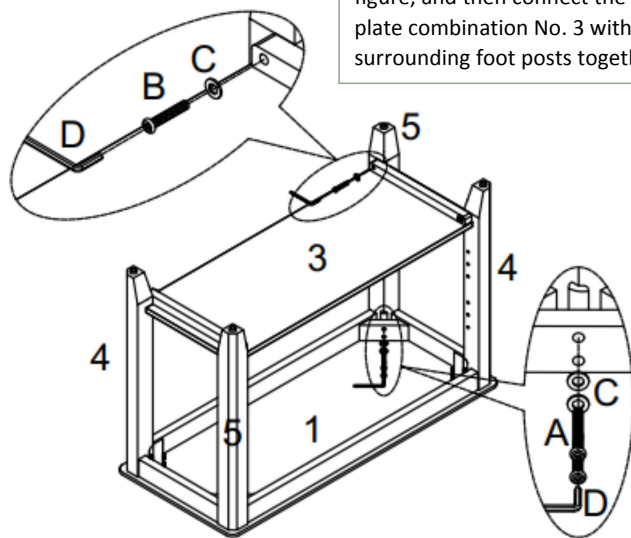

Note: After unpacking, please check whether the product is complete.
1. Assemble the left foot No. 4 and right foot No. 5 with the seat frame and bottom plate according to the drawing.

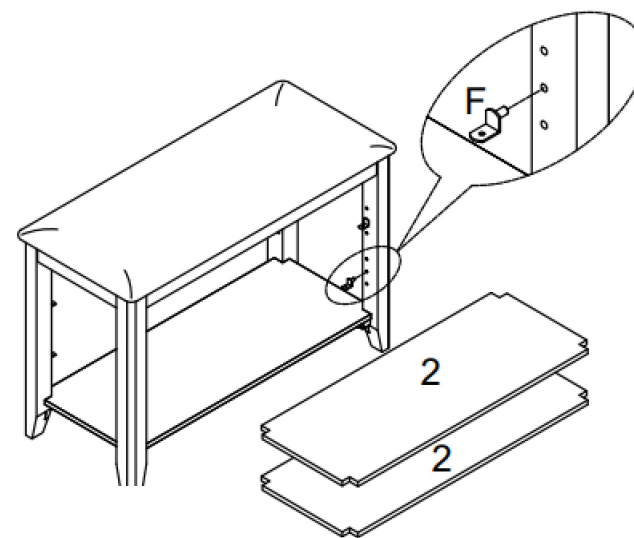

2. Install the layer support F on the foot post as shown in the figure, and then put the movable layer plate in the figure.

Step 3

3, the bottom of the foot column is installed with an adjustment pad, if the floor is not usually can be placed at the bottom of the adjustment pad to achieve balance.

