

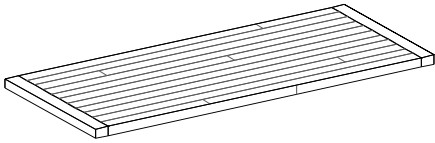

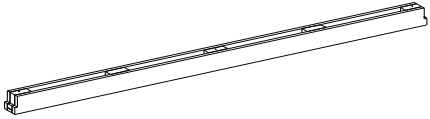
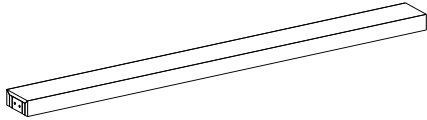
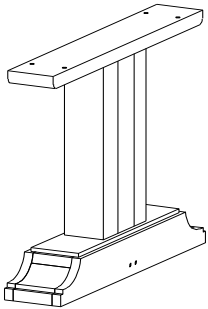
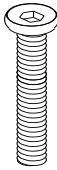
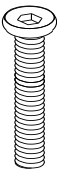

ASSEMBLY INSTRUCTIONS

PARTS LIST

A	TABLE TOP X 1		<p>Before beginning</p> <p>1 - Carefully unpack and position the item on a clean, non-marring surface to assemble.</p> <p>2 - Read this Assembly Instructions from beginning to end before starting to assemble.</p> <p>3 - Take an inventory of the required parts to ensure all are available.</p> <p>4 - To prevent accidental choking hazards, keep all packing materials away from small children.</p> <p>5 - Only tighten hardware until ALL hardware are fully engaged on their locations. Overtighten bolts will damage the bolt threads.</p> <p>6 - Use only factory provided hardware to assemble. Unapproved hardware can damage product or jeopardize the structural integrity of the product.</p> <p>7 - The use of power tool to assemble is not recommended due to high risk of over-torque, which can damage the product.</p>			
B	TOP SUPPORT X 1					
C	STRETCHER x1					
D	LEGS X 2					

Z	HARDWARE	<p>Z1</p>  <p>8X80MM X 7</p>	<p>Z2</p>  <p>8X60MM X 8</p>	<p>Z3</p>  <p>8X19X1.6MM X 15</p>	<p>Z4</p>  <p>8X12-13X2MM X 15</p>	<p>Z5</p>  <p>4X59MM X 1</p>	<p>Z6</p>  <p>X4 Adjustable Floor Glide (Pre-installed at the bottom of the legs)</p>		
---	----------	--	--	---	--	---	---	--	--

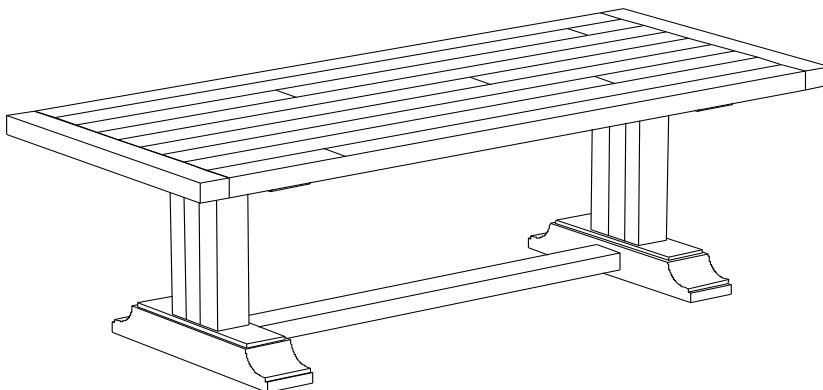

ASSEMBLY REQUIRES
TWO PEOPLE



15-MINUTE
ASSEMBLY TIME



KEEP INSTRUCTIONS
FOR FUTURE USE



ASSEMBLY INSTRUCTIONS

1

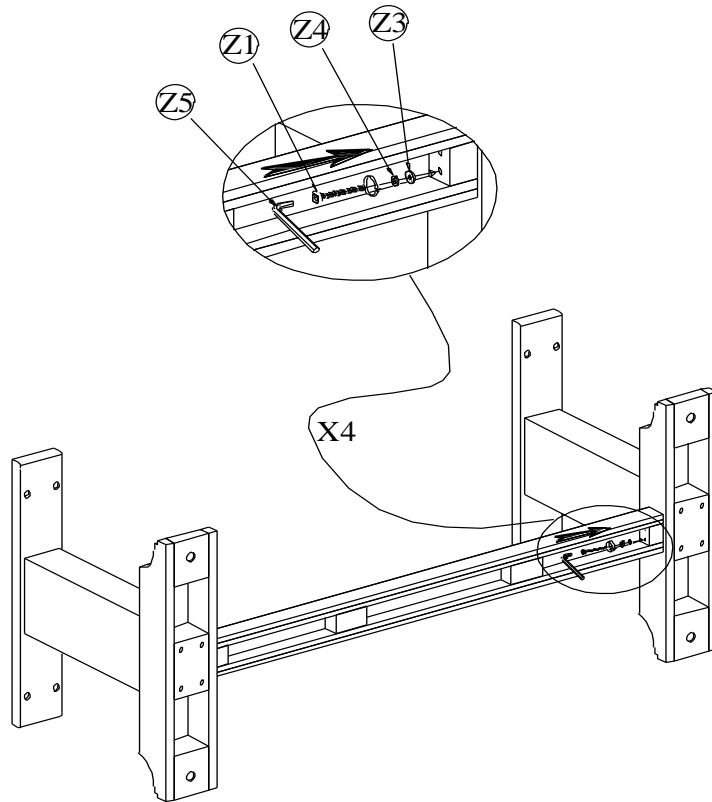

- Assemble the Stretcher (C) to the Legs (D), using Allen key (Z5) to tighten Allen Bolts (Z1), Spring Washers (Z4) and Washers (Z3).

2

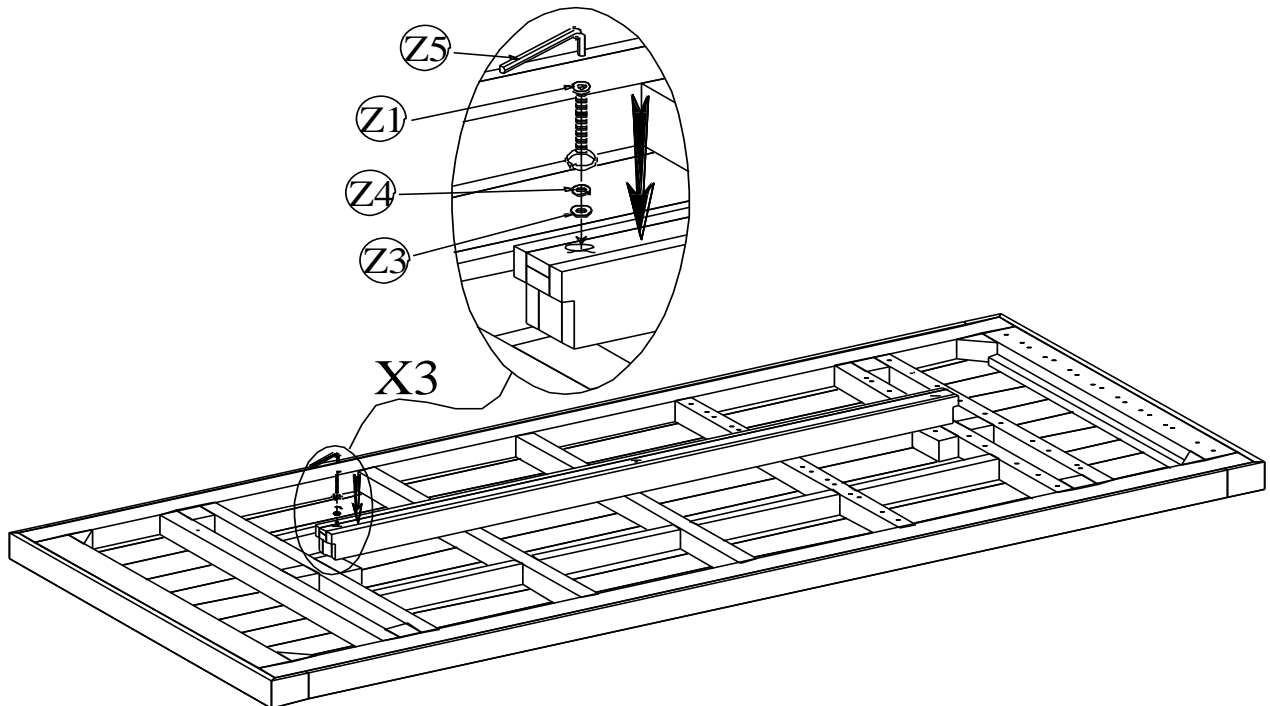

- Assemble the Top support (B) to the Table Top (A), Using Allen key (Z5) to tighten Allen Bolts (Z1), Spring Washers (Z4) and Washers (Z3).

ASSEMBLY INSTRUCTIONS

3

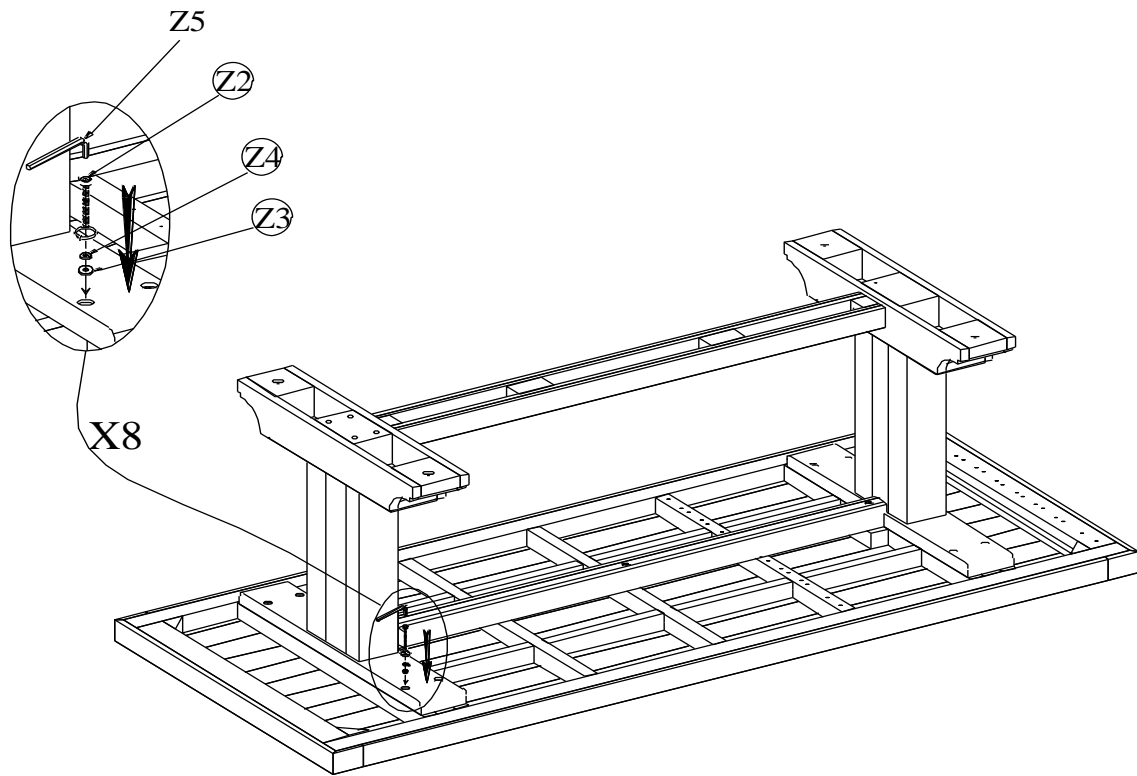

- Attach the Leg set into the Table Top (A).
- Using Allen key (Z5) to tighten Allen Bolts (Z2), Spring washers (Z4) and Washers (Z3).

4

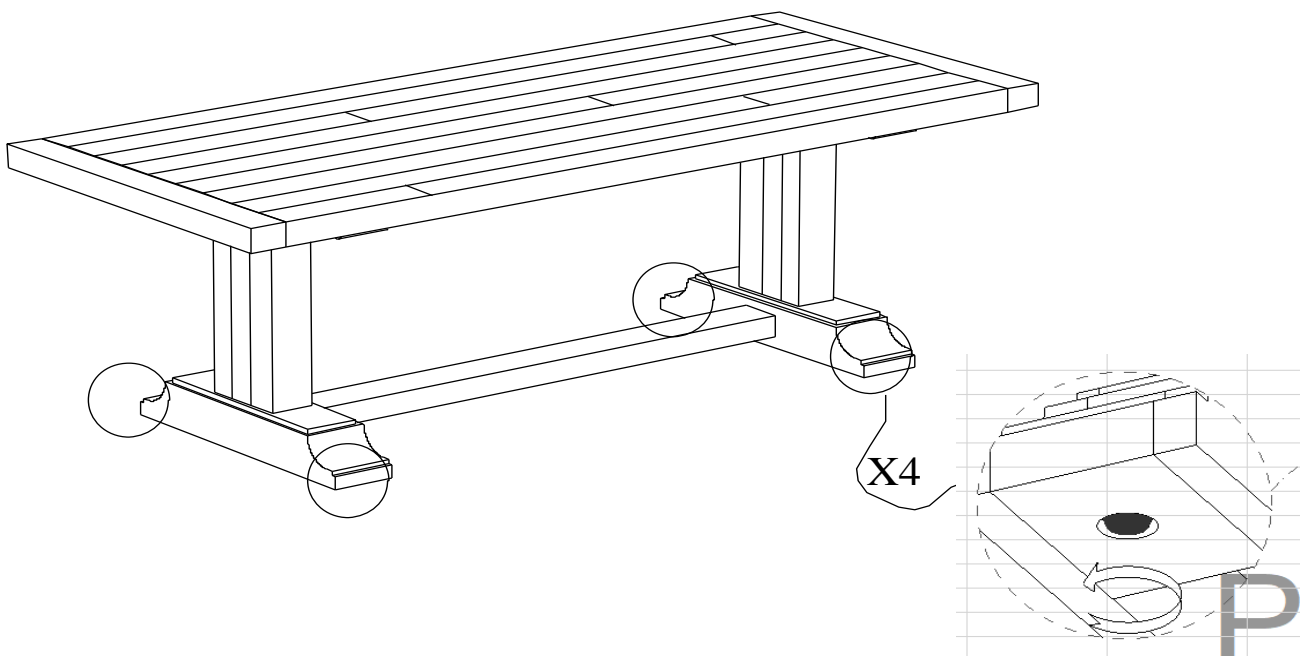

- With the assistance of two people, carefully flip the table over and position it on its legs.
- If the table is not level, make adjustments by using the adjustable floor glides beneath the legs.
- Assembly Completed