

ANCONA

Arezzo



Widespread Lavatory Bathroom Faucet

STANDARDS

- ASME A112.18.1/CSA B125.1
- ASME A112.18.2/CSA B125.2
- LISTED IAPMO/cUPC

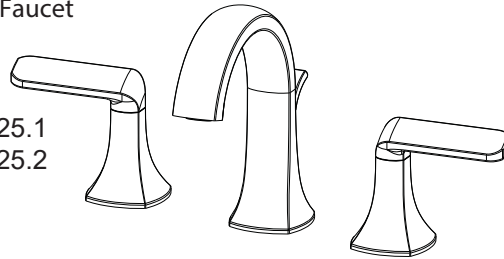

Flow Rate Chart

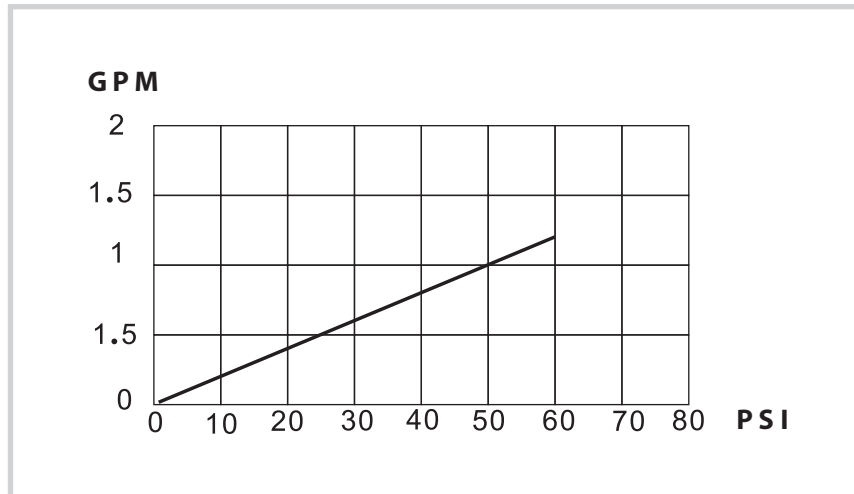

Helpful Information

Tools:

Gather the necessary tools as shown below to complete the installation of this faucet. Some may not be needed depending on the model of faucet you are installing. Check with your local hardware store on the requirements of your installation situation.

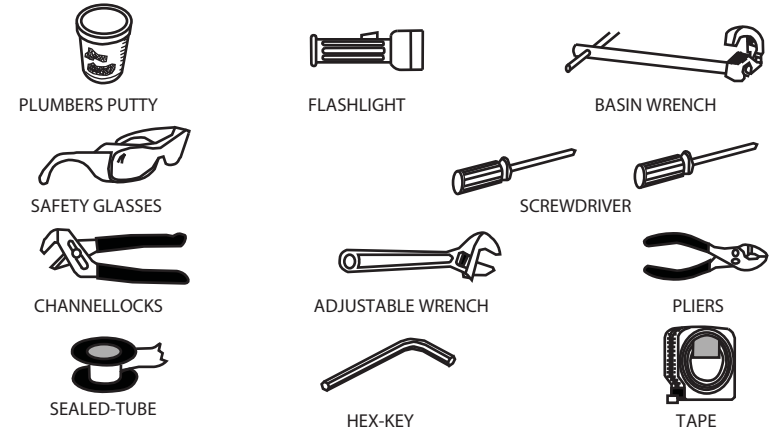

! WARNING:
Please keep the tools for future use!

Attention:

For easy installation, you will need:

- To read all the installation instructions completely before beginning.
- To read all the warning, attention and maintenance information.
- To purchase the proper supply lines.

Important

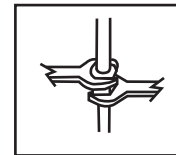

Tighten connection with two wrench to prevent damage to tube body. Be careful not to bend the stem as this will void the product warranty.

Connect to water supply lines with either:
 (A) 3/8" O.D.copper tubing (ball nose risers with the coupling nuts or;
 (B) 3/8" copper tubing (no ball)with supplied tube head interior connector or;
 (C) IPS faucet connectors (1/2") .

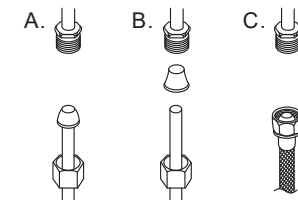

3

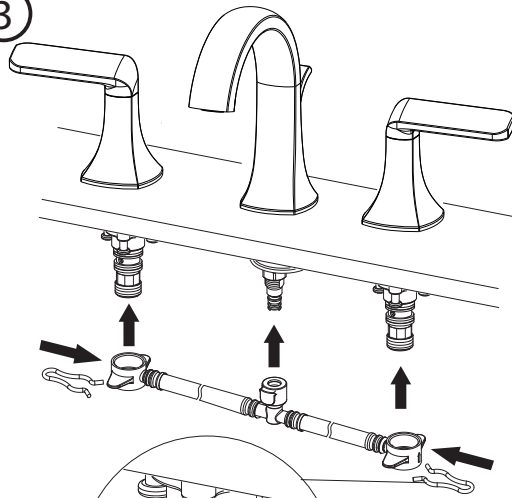

Position the flexible hose and fix it to the faucet as shown with clamp spring.

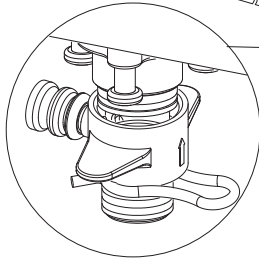

4

Connect the water supply lines to faucet and water supply valve and tighten with wrench.

Warning: The water supply valves mentioned above are not included, please purchase them at your local hardware store.

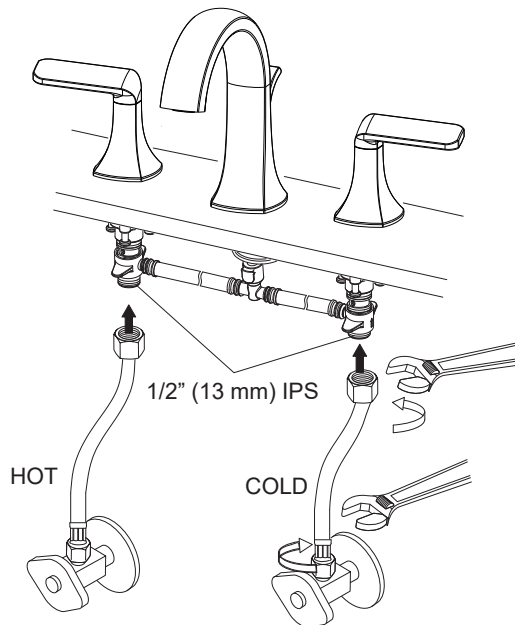

**WARNING:
DON'T OVERTIGHTEN!**

Checking and Testing

5

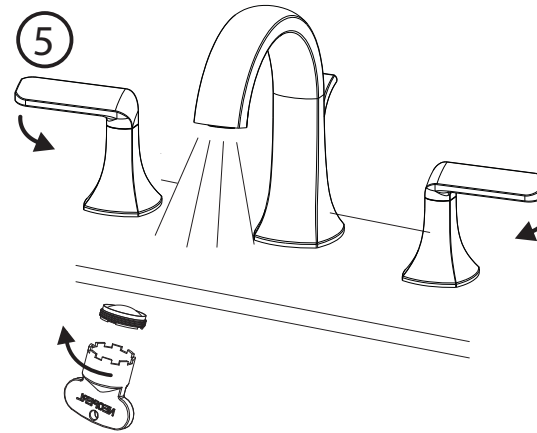

Remove the aerator by aerator wrench. Turn the faucet handle all the way on, turn on hot and cold water supply and flush water lines for one minute. Reinstall aerator by aerator wrench.

6

Check all connections at arrows for leaks, retighten if necessary.



BUT DON'T OVERTIGHTEN

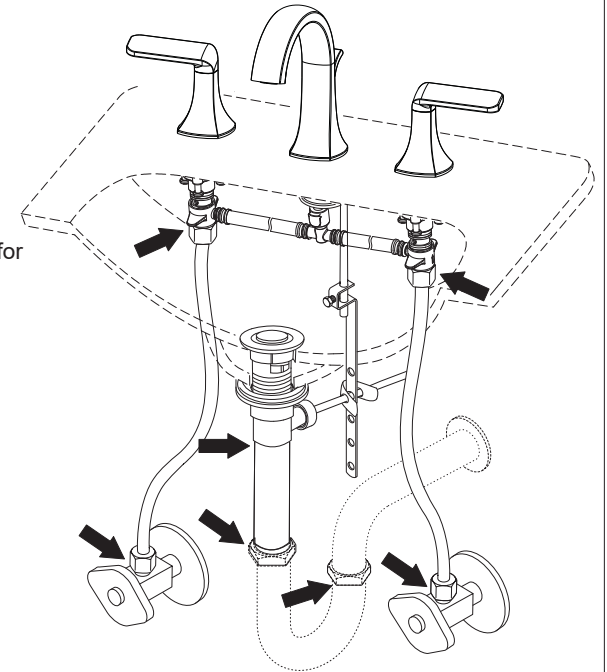

Maintenance:

Simply rinse the surface with clear water or mild liquid detergents (if necessary). Dry the faucet with a clean soft cotton cloth. Do not use any cleaning agents containing acids polish abrasives or harsh cleaners.

Cleaning and care

Daily cleaning and care are required in order to keep the product shining and working properly.

1. Clean it with water and dry it with soft cloth.
2. Clean the product with gentle liquid or glass cleaner.
3. Don't use acid cleaner.
4. Don't clean with abrasive material, abrasive paper or knife.

ANGONA

 **WARNING**

 **ATTENTION**

Ensure hoses are tightly screwed in position as they may move during transportation and installation.

Assurez-vous de bien serrer les embouts de chaque Tuyau car ils peuvent se dévisser lors du transport – bien valider après l'installation aussi

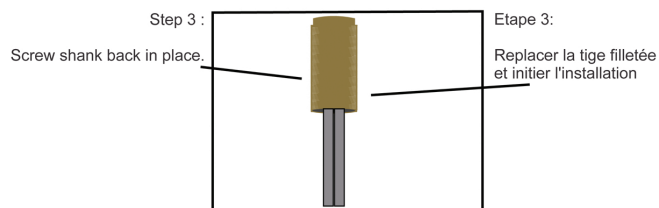
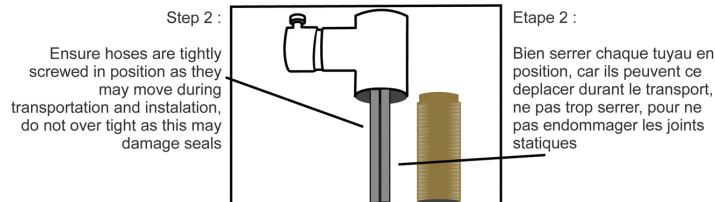
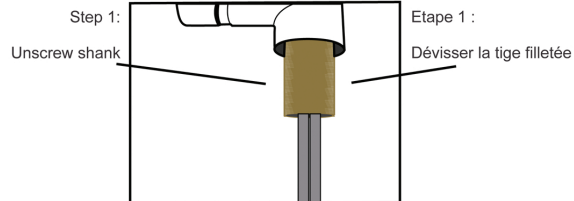

Parts list

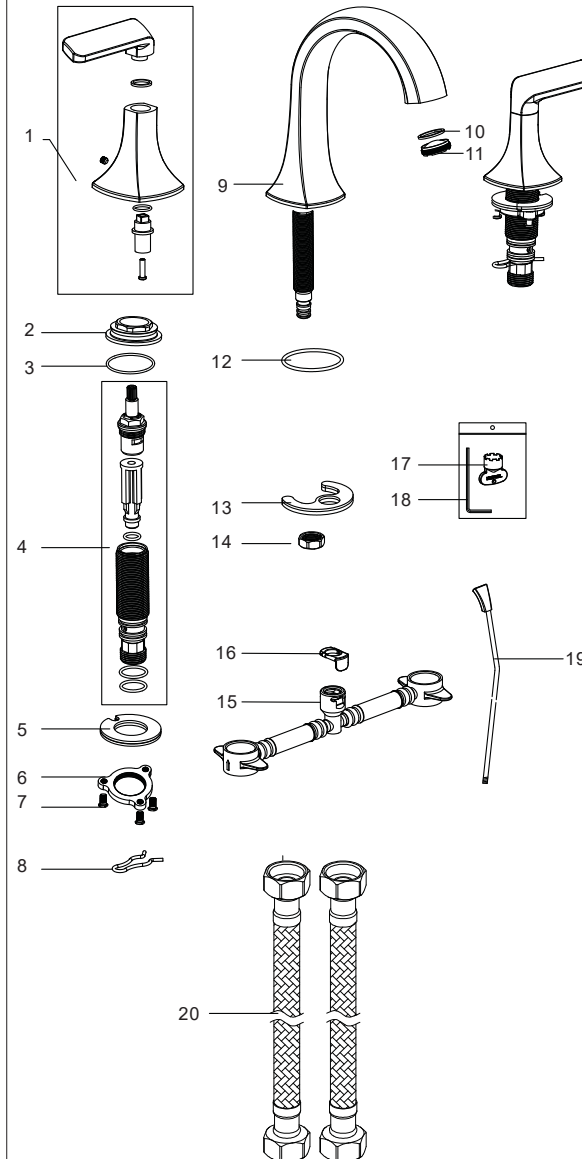

NO.	PART NAME
1	Handle assembly
2	Lock nut
3	O-ring
4	Water valve assembly
5	Gasket assembly
6	Lock nut
7	Screw
8	Clamp spring
9	Spout
10	Washer
11	Aerator
12	O-ring
13	Gasket assembly
14	Lock nut
15	Flexible hose
16	Plastic lock ring
17	Aerator wrench
18	Allen key
19	Lift rod
20	Inlet pipe