

Assembly Instructions

Loveseat

CAUTION: You must read this before you proceed

Please look in the Seat frame for hardware packs

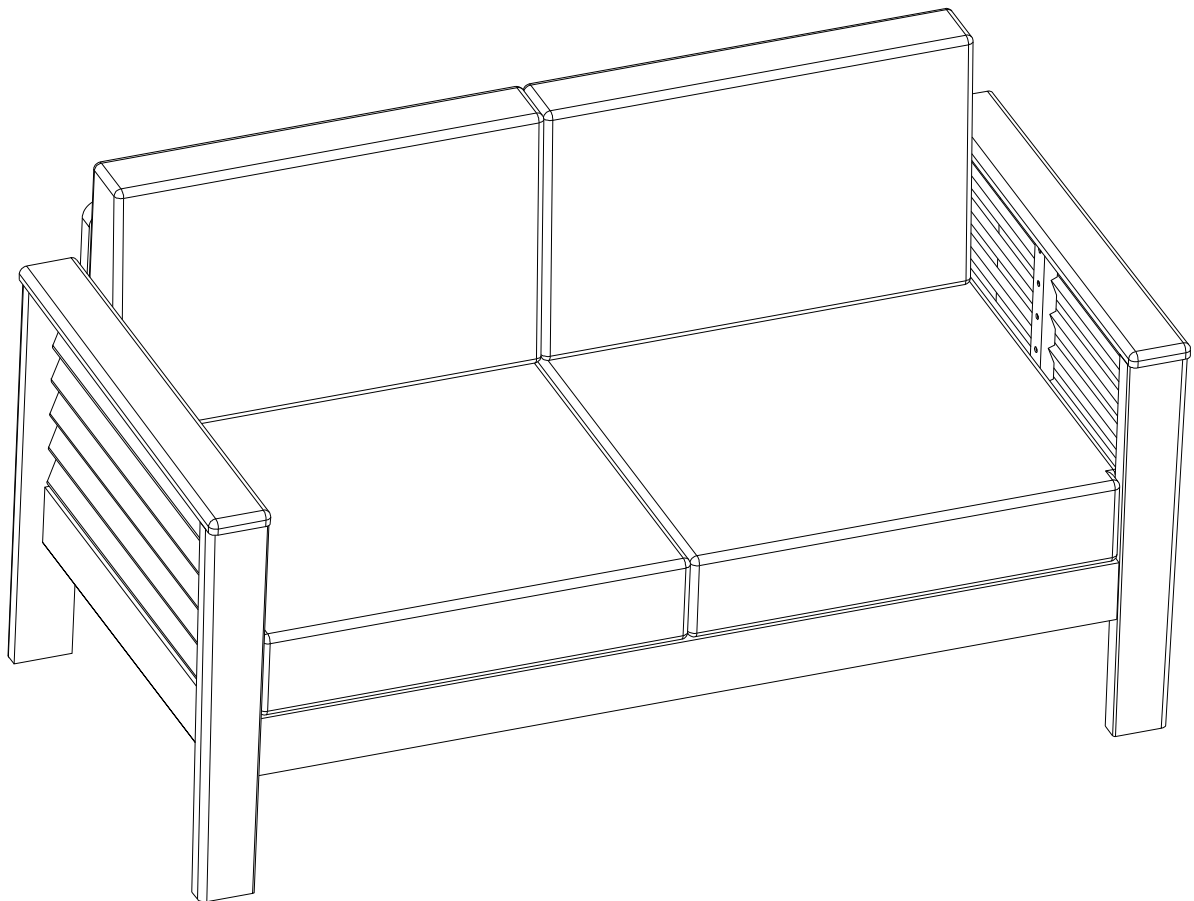

CAUTION: This Chair is NOT a TOY.

Keep your child/children at bay during the assembly process.

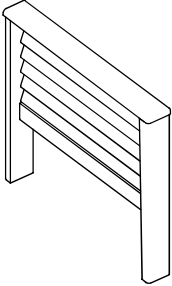
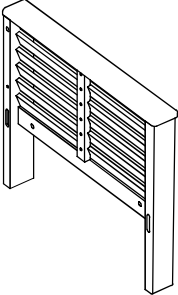
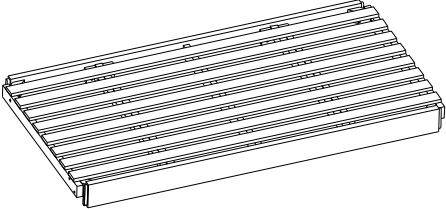
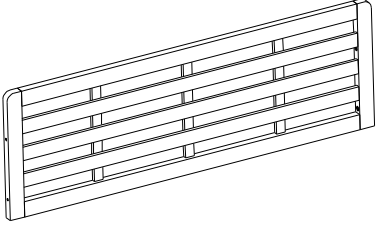
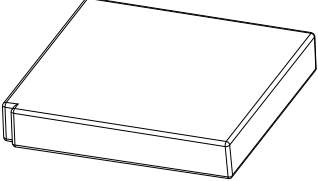
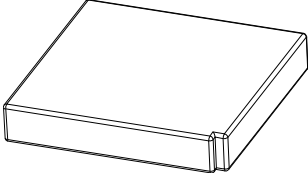
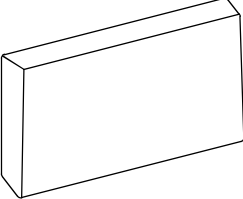

Whenever lifting the Loveseat and to prevent any possible damage to it, two adults are needed to execute this action.

Parts List

No.	Picture	Description	Qty
A	 A line drawing of a rectangular panel with four horizontal slats, attached to a vertical leg on the right side.	Left Leg Panel	1
B	 A line drawing of a rectangular panel with four horizontal slats, attached to a vertical leg on the left side.	Right Leg Panel	1
C	 A line drawing of a rectangular panel with ten horizontal slats.	Seat Panel	1
D	 A line drawing of a rectangular panel with six horizontal slats and a vertical support on the left side.	Backrest	1
E	 A line drawing of a rectangular cushion with a slightly raised edge on the left side.	Left Seat Cushion	1
F	 A line drawing of a rectangular cushion with a slightly raised edge on the right side.	Right Seat Cushion	1
G	 A line drawing of a rectangular cushion.	Back Cushion	2

Hardware

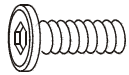
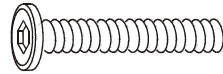
Table Hardware

No.	Picture	Description	Qty
①		Bolt (M6 x 35mm)	7
②		Bolt (M6 x 65mm)	5
③		Allen Key	1

Assembly Preparation

Before Beginning Assembly:

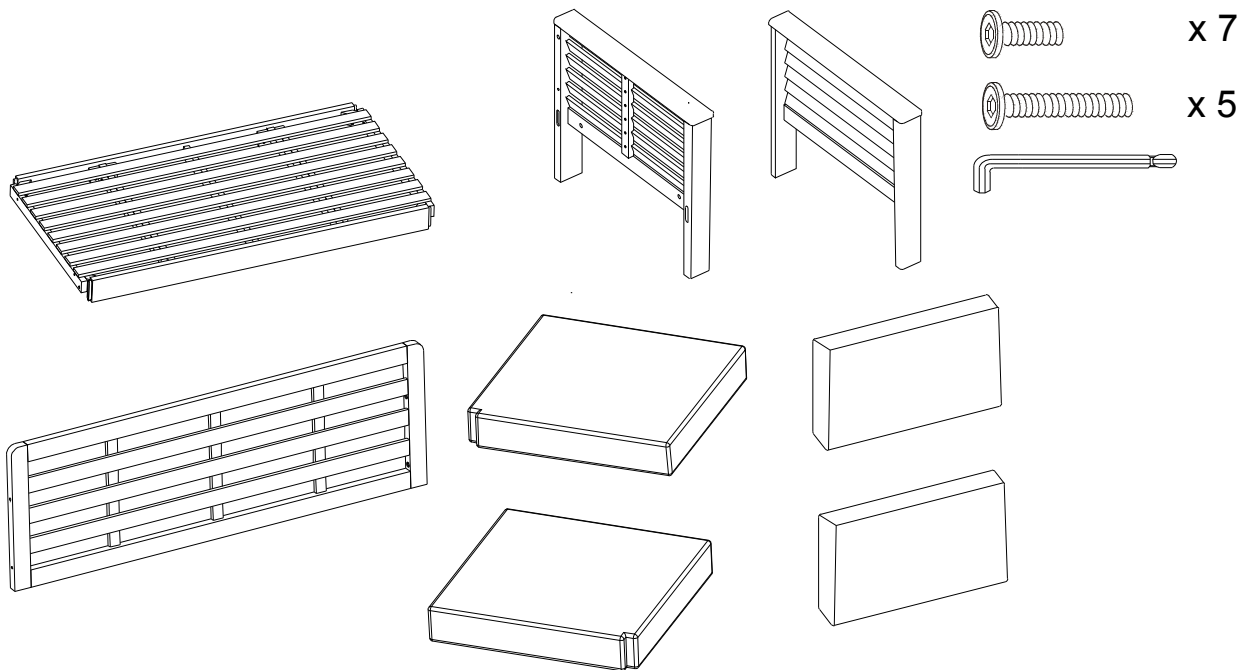

Read instructions, cover to cover.



Have 2 adults on hand for assembly.



Do not assemble on flooring or carpet.



Assemble on a clean non-marring surface (packing foam).



Save all packaging until finished.

Assembly Steps

OVERVIEW

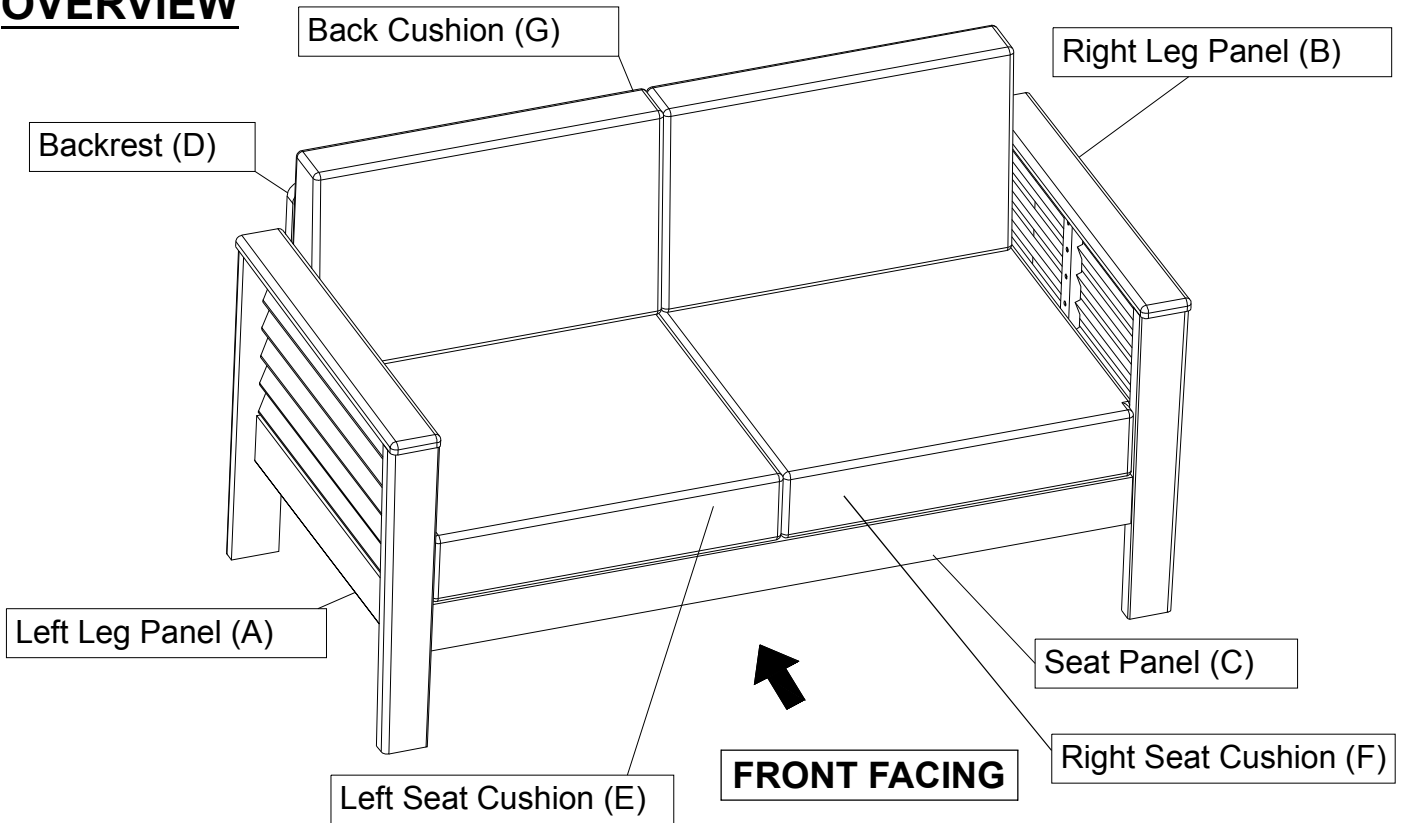

This Loveseat has multiple parts and may require up to 30 minutes to assemble. To give you an overview of the Loveseat parts, the above picture is to help you put the various parts into perspective. Please read through the instructions below to familiarise yourself with the parts and steps before assembly.

Step 1

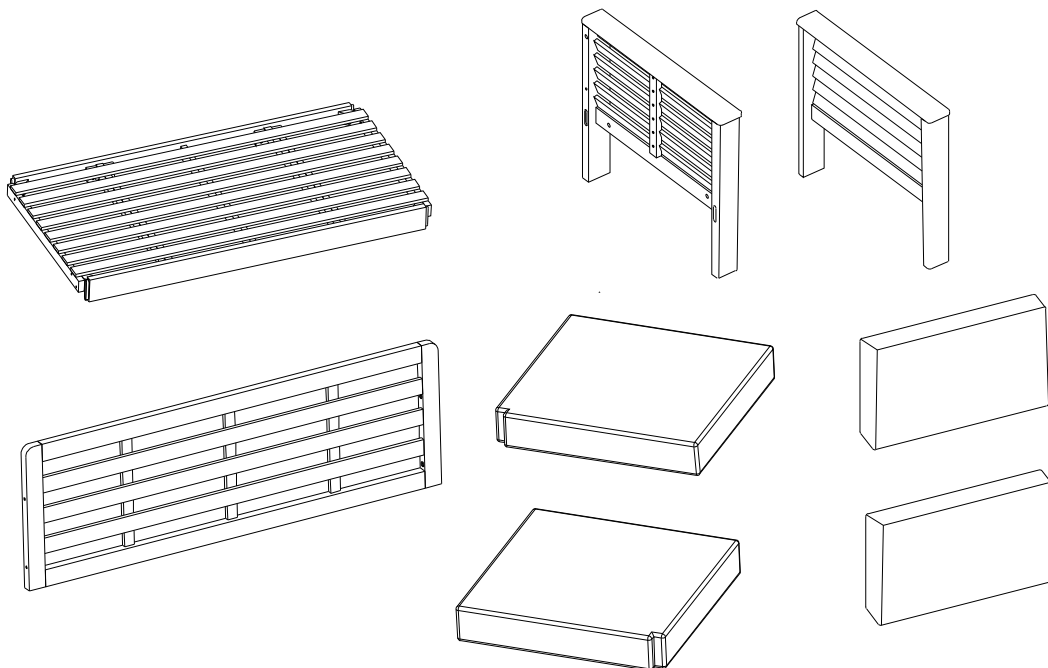

Unpack and place all parts on a clean, non-marring surface.

Assembly Steps

Step 2

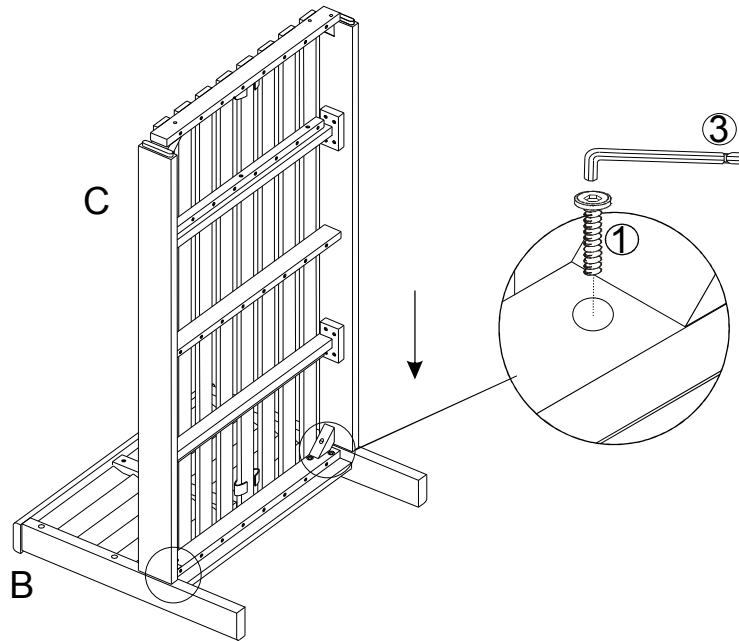

Place the Right Leg Panel (B) on a clean, non-marring surface
With the help of your adult partner, attach the Seat Panel (C) to the Right Leg Panel (B)
using Bolts (1) and Allen Key (3) as shown above.
Do not fully tighten the Bolts.

Step 3

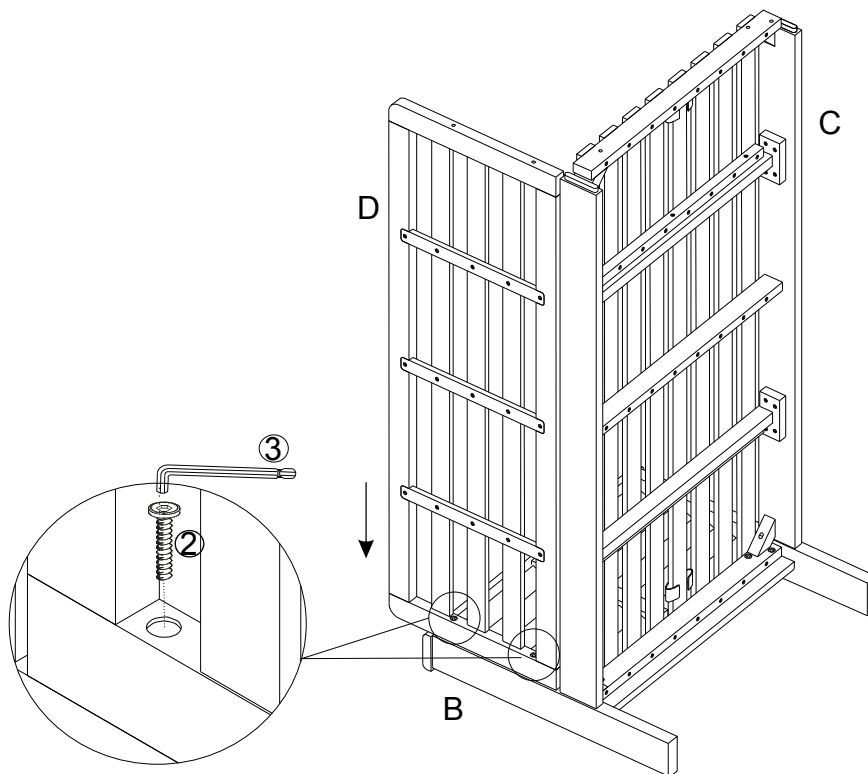

With the help of your adult partner, attach the Backrest (D) to the Right Leg Panel (B)
in assemble on step 2 using Bolts (2) and Allen Key (3) as shown above.
Do not fully tighten the Bolts.

Assembly Steps

Step 4

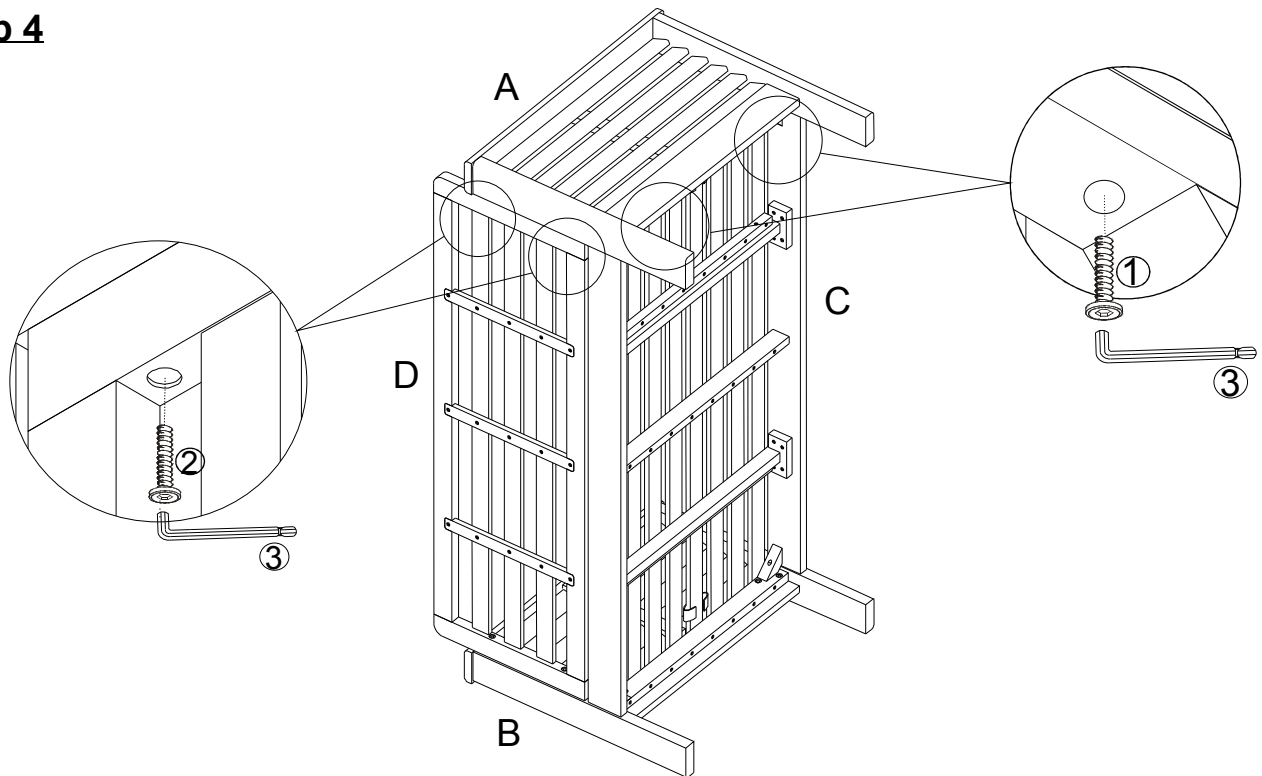

With the help of your adult partner, attach the Left Leg Panel (A) to the Seat Panel (C) and Backrest (D) in assemble on step 3 using Bolts (①), Bolts (②) and Allen Key (③) as shown above.

Do not fully tighten the Bolts.

Step 5

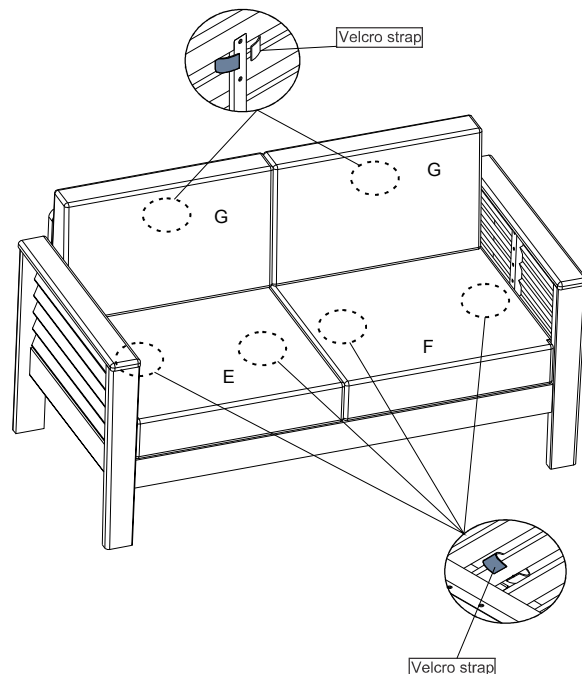

With the assistance of your adult partner, stand the Loveseat up. Place Left Seat Cushion (E) and Right Seat Cushion (F) on to Seat Panel (D). Stick the velcro of Left Seat Cushion (E) and Right Seat Cushion (F) to Seat Panel (D). Place Back Cushion (G) on to Backrest (F). Stick the velcro of Back Cushion (G) to the Backrest (C) as show in above picture.

Step 6

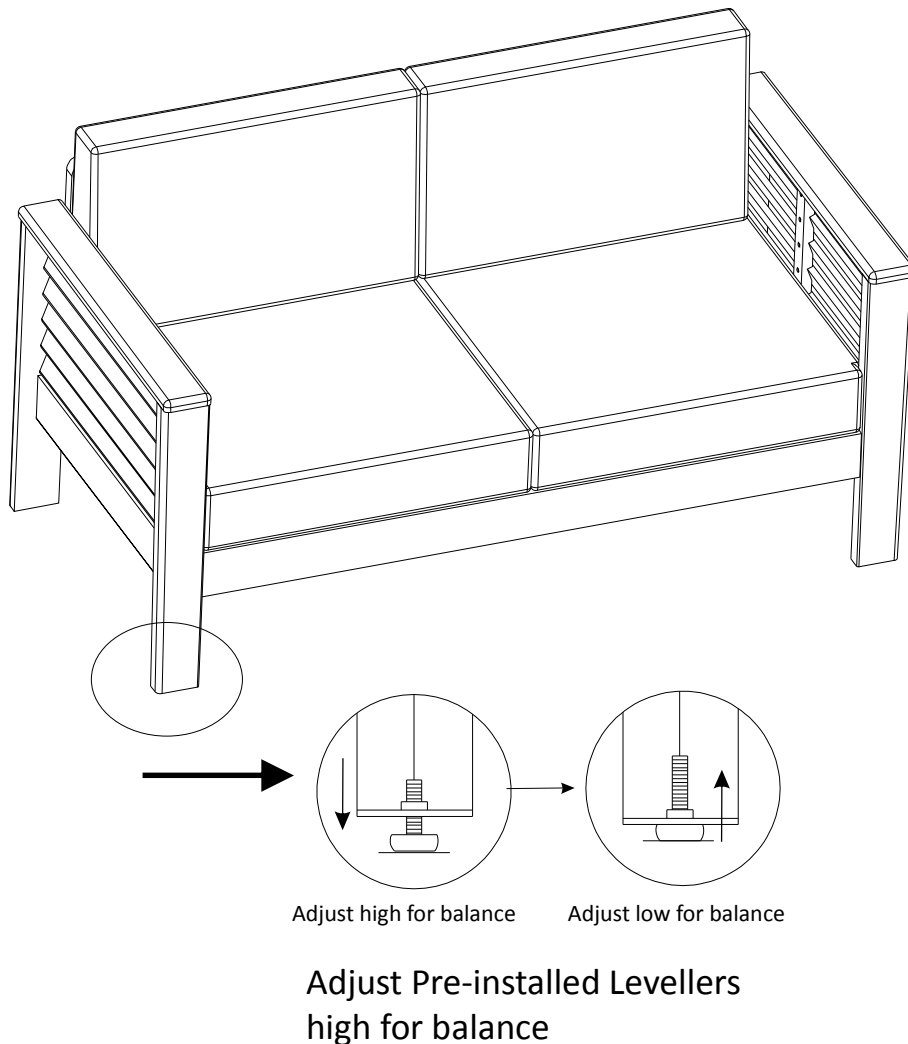

Place the Loveseat onto a flat, level surface.

Then EXERT pressure, floorwards onto the Loveseat with both hands.

This pressure will help the Loveseat reach full alignment at all joints.

In a sequential manner, gradually tighten all Bolts at all joints until evenly secured. Inspect the Loveseat and make sure all parts are adequately connected.









Adjust the Levellers until the Loveseat is level with the ground.

To adjust the Levellers, get assistance from an adult partner to lift/lean and hold the Loveseat while you are working.

Your Loveseat is ready for use.

This Loveseat can only be used on a flat, level surface.

Care & Maintenance

-  Do not put hot items directly on furniture surface.
-  Do not clean furniture with harsh cleansers or polish.
-  To obtain the longest lifespan of your outdoor products, minimizing exposure to direct sunlight is recommended.
-  Children should not climb or jump on the furniture.
-  Do not write on furniture without a padded barrier to protect the surface.
-  To obtain the longest lifespan of your outdoor products, avoid extended and lengthy exposure to rain, snow, and direct sunshine. Whenever possible cover the product and /or place under patio or awnings.
-  Not for commercial use. For residential use only
-  Stains may be removed with mild soap solution and damp cloth.
-  Dust and pick-up spills using a clean, non-colored, lint-free cloth.

Assembly Instructions

Table

CAUTION: You must read this before you proceed

Pleas look in the Table top for hardware packs

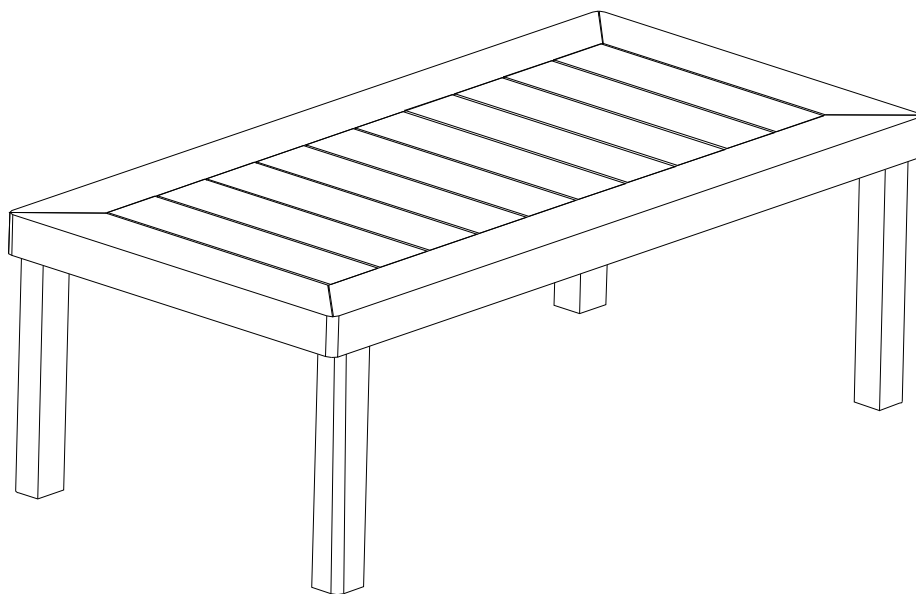



CAUTION: This Table is NOT a TOY.

Keep your child/children at bay during the assembly process.

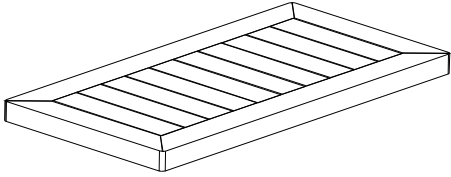

Whenever lifting the Table and to prevent damage to the Table two adults are needed to execute this action.

Parts List

No.	Picture	Description	Qty
H		Left Leg	2
I		Right Leg	2
J		Table top	1

Hardware

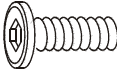
Table Hardware

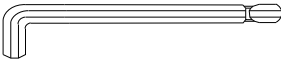
No.	Picture	Description	Qty
④		Bolt (M6 x 35mm)	9
⑤		Washer (M6.5x16x1mm)	9
⑥		Allen Key	1

Assembly Preparation

Before Beginning Assembly:

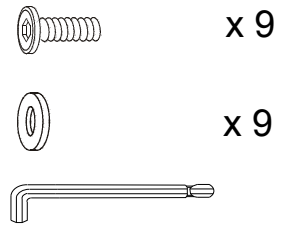
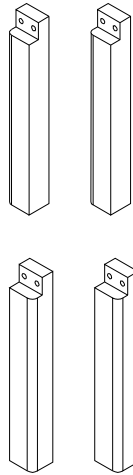
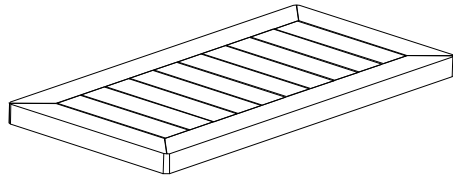

Read instructions, cover to cover.



Have 2 adults on hand for assembly.



Do not assemble on flooring or carpet.



Assemble on a clean non-marring surface (packing foam).



Save all packaging until finished.

Assembly Steps

OVERVIEW

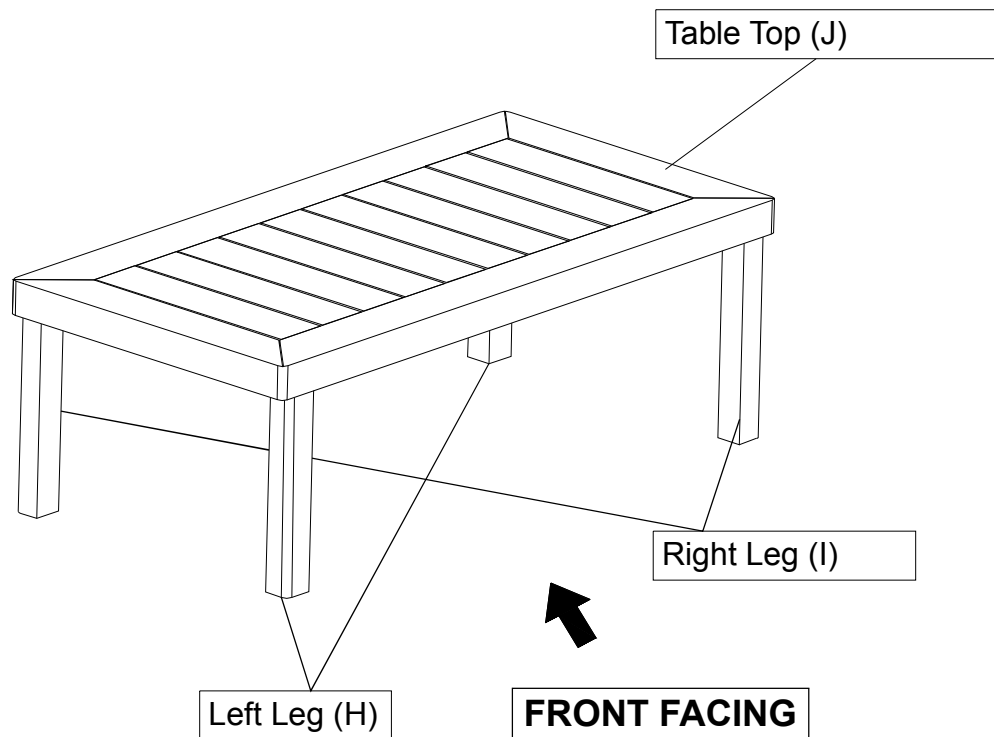

This Table has multiple parts and may require up to 30 minutes to assemble. To give you an overview of the Table parts, the above picture is to help you put the various parts into perspective. Please read through the instructions below to familiarise yourself with the parts and steps before assembly.

Step 1

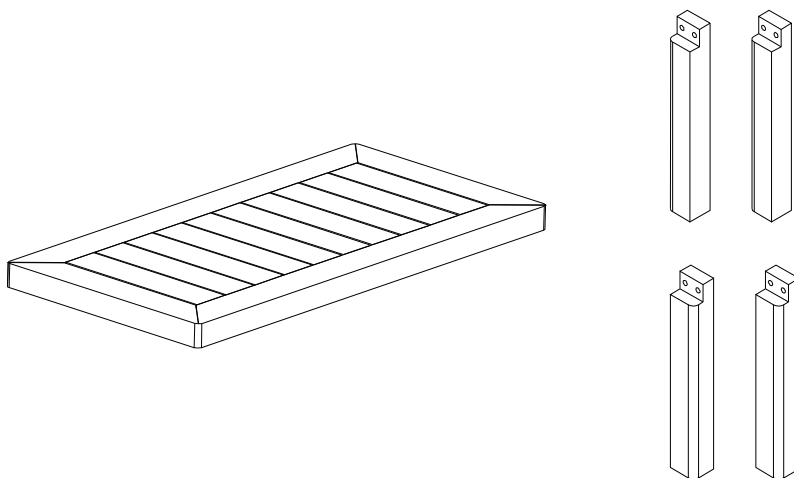

Unpack and place all parts on a clean, non-marring surface.

Assembly Steps

Step 2

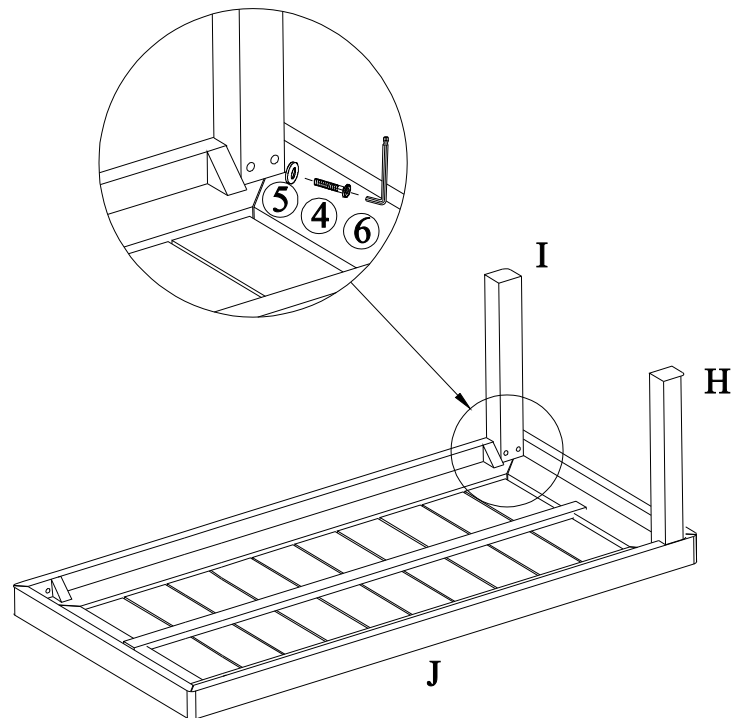





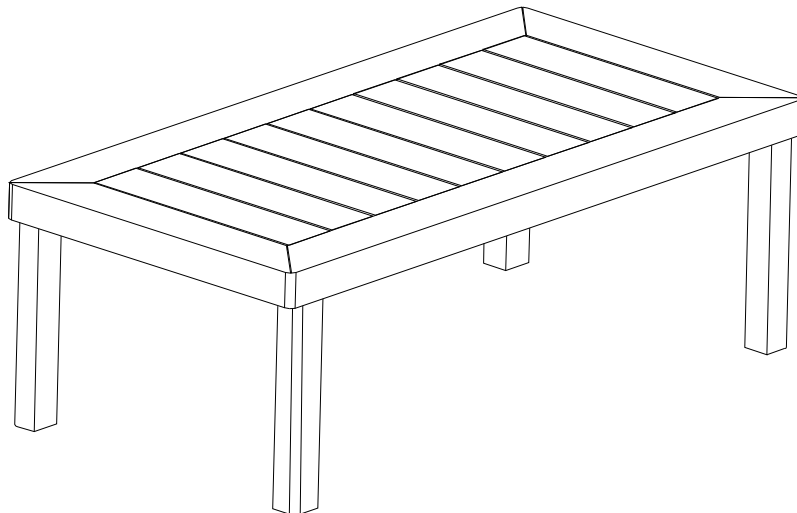













Place the Table Top (J) facedown as shown above.
Attach the Right Leg(I) and the Left Leg (H) to Table Top(J) using Bolts (④)
and Washer (⑤)
with Allen key(⑥) as shown in picture above.
Repeat the same process with remain Right Leg(I) and the Left Leg (H)
Do not fully tighten the Bolts.

Step 3



With the assistance of your adult partner, stand the Table up.
Place the Table onto a flat, level surface.
Then EXERT pressure, floorwards onto the Table with both hands.
This pressure will help the Table reach full alignment at all joints.
In a sequential manner, gradually tighten all Bolts at all joints until evenly secured.
Inspect the Table and make sure all parts are adequately connected.
Your Table is ready for use.
This Table can only be used on a flat, level surface.

Care & Maintenance

-   Do not put hot items directly on furniture surface.
-   Do not clean furniture with harsh cleansers or polish.
-   To obtain the longest lifespan of your outdoor products, minimizing exposure to direct sunlight is recommended.
-   Children should not climb or jump on the furniture.
-   Do not write on furniture without a padded barrier to protect the surface.
-   To obtain the longest lifespan of your outdoor products, avoid extended and lengthy exposure to rain, snow, and direct sunshine. Whenever possible cover the product and /or place under patio or awnings.
-   Not for commercial use. For residential use only
-   Stains may be removed with mild soap solution and damp cloth.
-   Dust and pick-up spills using a clean, non-colored, lint-free cloth.