

148 × 210mm

STORAGE BOX

ASSEMBLE INSTRUCTIONS

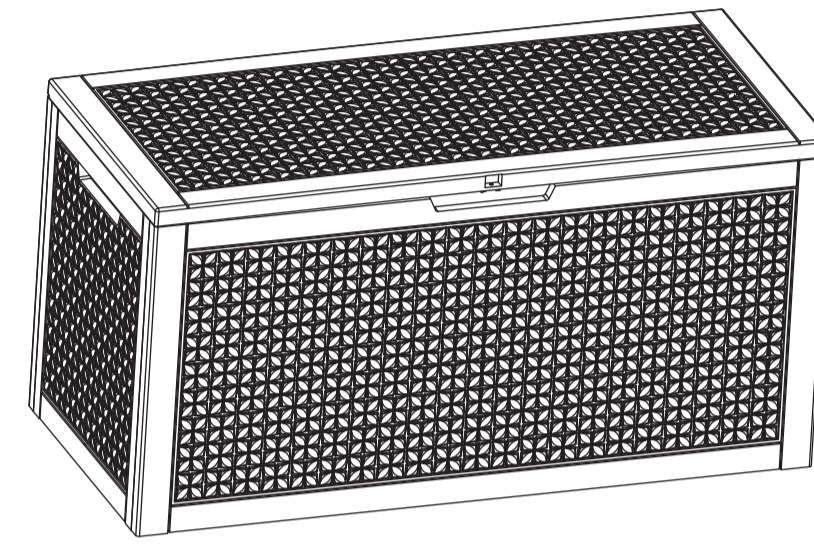

130A

IMPORTANT

Once installed, the product cannot be detached. Strictly follow each step in the installation manual.

- Gather and organize all required parts prior to assembly. If you have any problems or discover any missing parts, please contact customer service.
- Some parts may contain sharp edges. Wear protective gloves if necessary during assembly.

CARE & SAFETY

- Assemble on a flat, clean and soft surface.
- In case of fire, do not attempt to extinguish any burning polypropylene with water.
- Wear safety-goggles and always follow the manufacturer's instructions when using power tools.
- During installation, please refer to the accessories guide to ensure that they are installed in the correct directions.
- Do not stand on the lid.

PARTS LIST

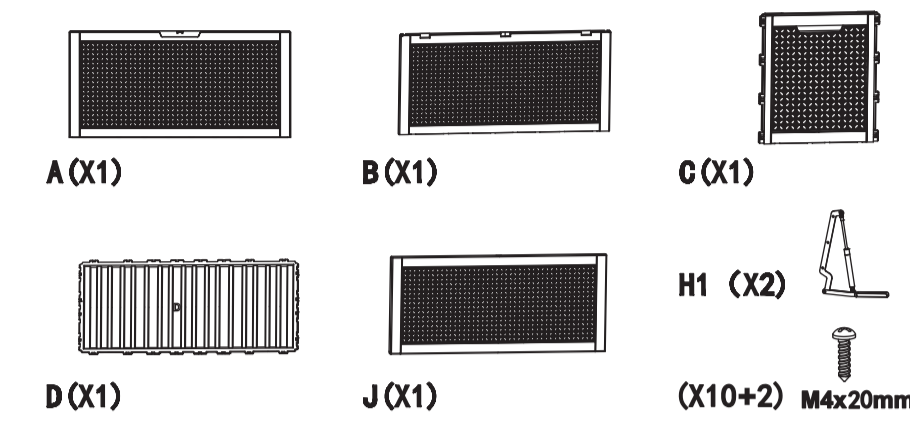

1 D (X1) C (X2)

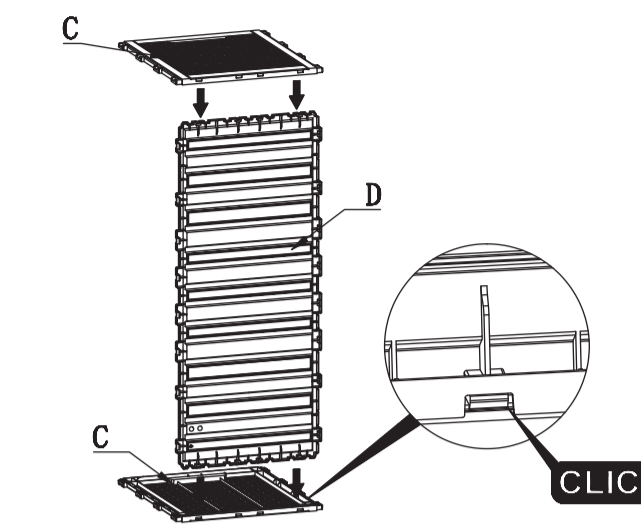

2 B (X1)

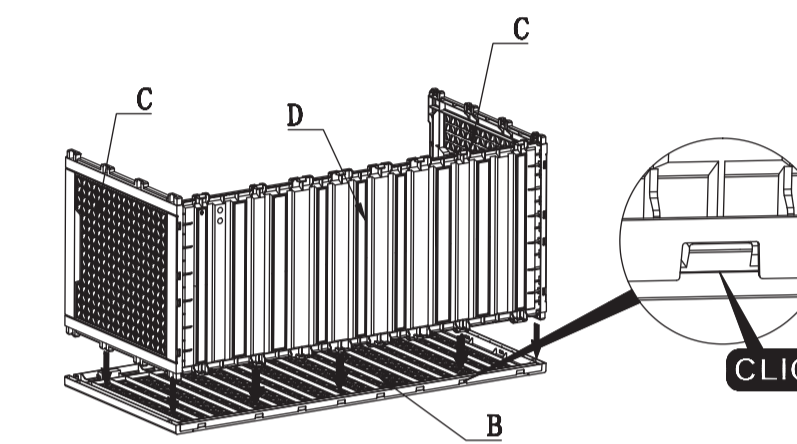

3 A (X1)

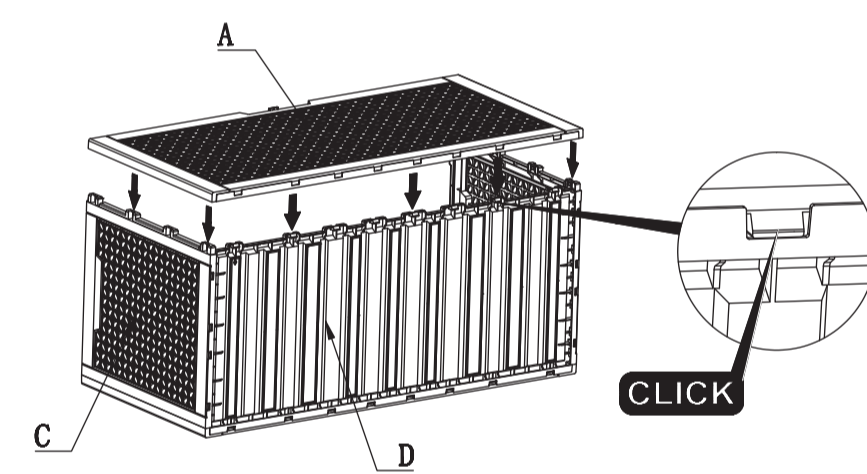

5 H1 (X2)

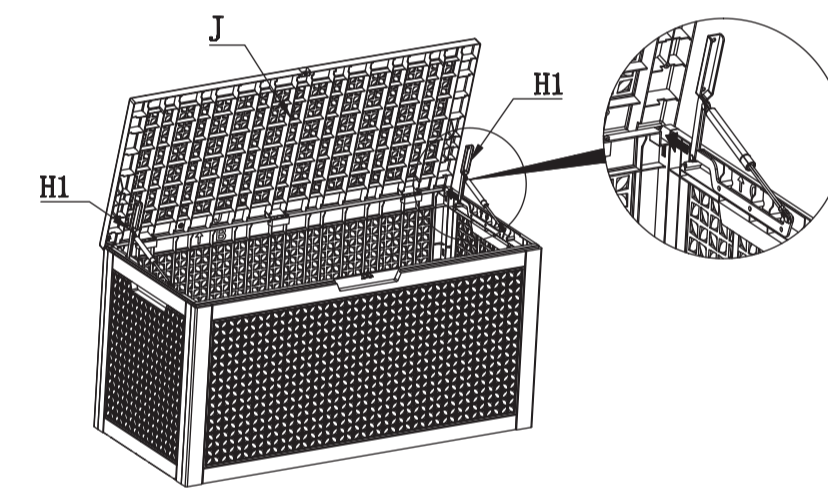

4 J (X1)

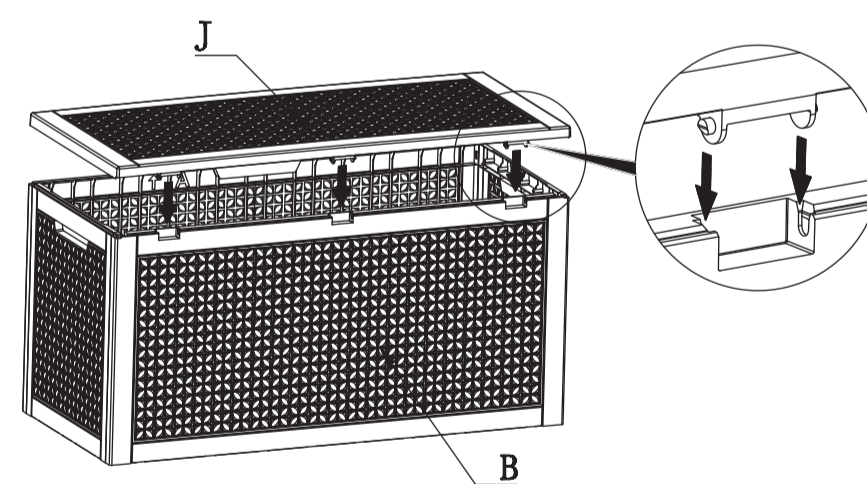

6 M4x20 (X10)

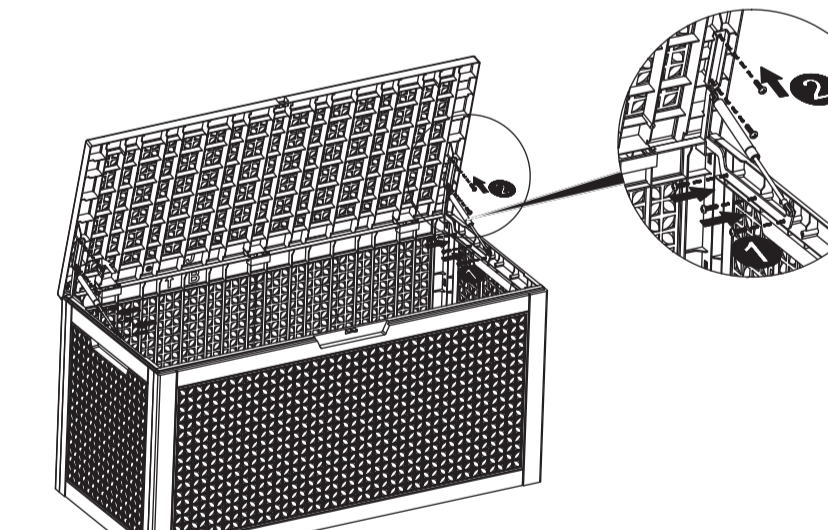

7

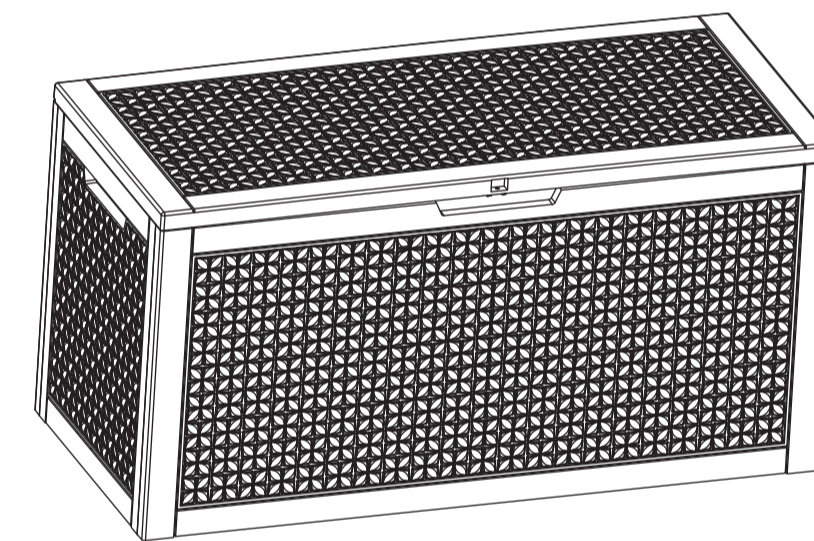

WARRANTY

The warranty is valid as of the date of purchase. Any product or part which fails due to structural defect or faulty workmanship, or which fails due to fading of color, for a one year period from the initial date of purchase.

**WARNING**

This product contains Polycyclic aromatic hydrocarbons (PAHs) which is known to the state of California to cause cancer birth defects and other reproductive harm. Do not ingest. For more information: [www.P65Warnings.ca.gov](http://www.P65Warnings.ca.gov).