

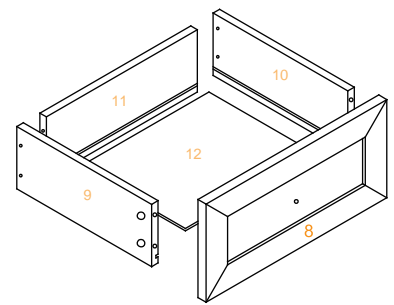

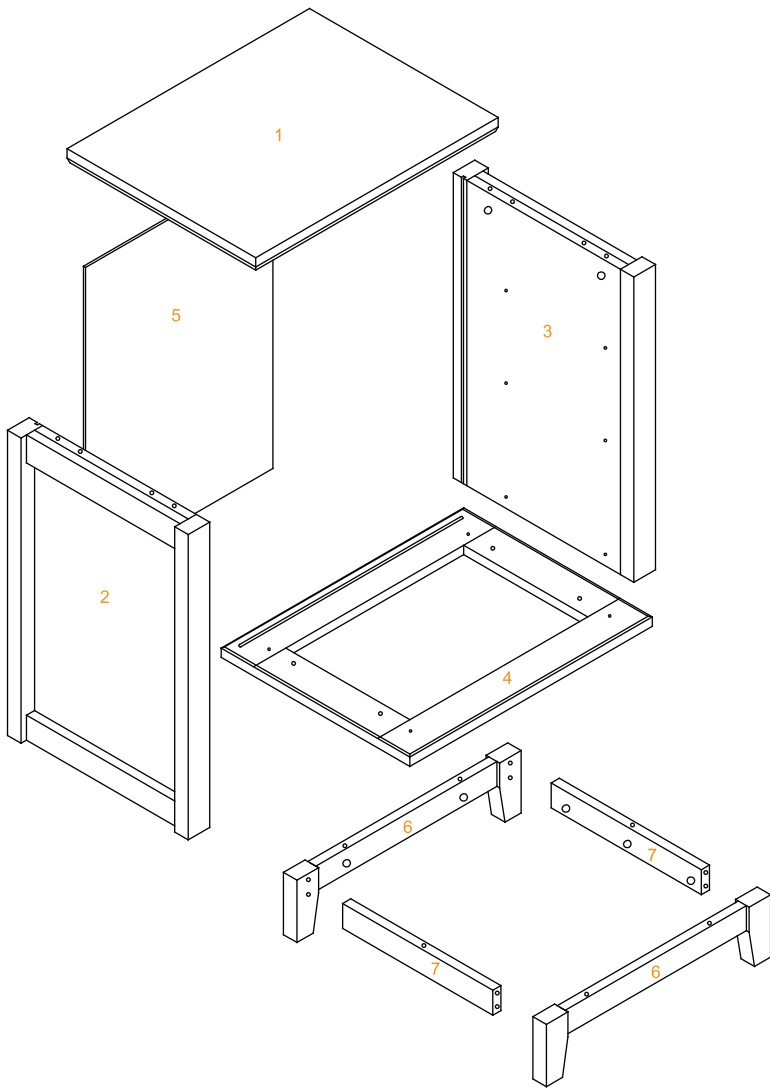

INSTRUCTION MANUAL

TOOLS REQUIRED

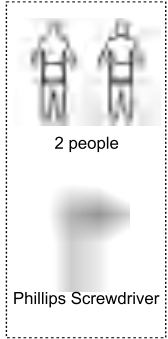

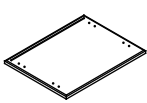
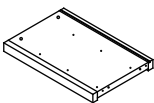
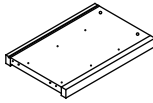
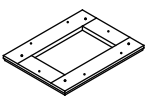
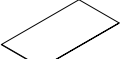
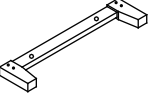
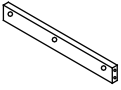



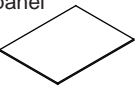



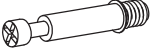





x 3

☰ PARTS LIST

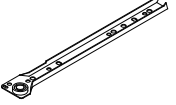
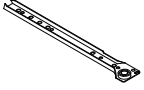
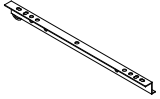
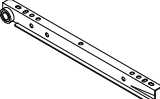
- | | | | | | |
|--|--|--|--|---|---|
| 01
Top panel

1 PC | 02
Left side panel

1 PC | 03
Right side panel

1 PC | 04
Bottom panel

1 PC | 05
Back panel

1 PC | 06
Front leg

2 PCS |
| 07
Trim

2 PCS | 08
Drawer front

3 PCS | 09
Drawer left side panel

3 PCS | 10
Drawer right side panel

3 PCS | 11
Drawer back panel

3 PCS | 12
Drawer bottom panel

3 PCS |

☰ HARDWARE LIST

<p>A</p> <p>Ø6x35mm Cam Bolt</p>  <p>26+1 PCS</p>	<p>B</p> <p>Ø15x10mm Cam Lock</p>  <p>26+1 PCS</p>	<p>C</p> <p>Ø6x30mm Dowel</p>  <p>12+1 PCS</p>	<p>D</p> <p>Ø5x40mm Screw</p>  <p>4 PCS</p>	<p>E</p> <p>Ø3x12mm Screw</p>  <p>24+3 PCS</p>	<p>F</p> <p>Ø3x14mm Back Buckle Screw</p>  <p>4 PCS</p>
<p>G</p> <p>Hold Hands</p>  <p>3 PCS</p>	<p>H</p> <p>M4x16mm Handle Bolt</p>  <p>3 PCS</p>	<p>I</p> <p>Ø4x30mm Screw</p>  <p>12+1 PCS</p>	<p>J</p> <p>Back Buckle</p>  <p>4 PCS</p>	<p>K</p> <p>Plastic Expansion Anchor K-1</p> <p>Self-Tapping Screw K-2</p>  <p>2 PCS</p>	<p>CL</p>  <p>3 PCS</p>
<p>CR</p>  <p>3 PCS</p>	<p>DL</p>  <p>3 PCS</p>	<p>DR</p>  <p>3 PCS</p>	<p>L</p> <p>Anti-fall Strip L-1</p> <p>Large Flat Head Screw L-2</p>  <p>2 PCS</p>	<p>M</p>  <p>4 PCS</p>	<p>N</p>  <p>12 PCS</p>



If you are missing any parts, please provide your order number and circle the part number. Send us a photo of this, and we will provide you with a satisfactory solution. Thank you.

STEP 1

Please tighten the screws after completing all installation.

Por favor, apriete los tornillos después de instalar todo.

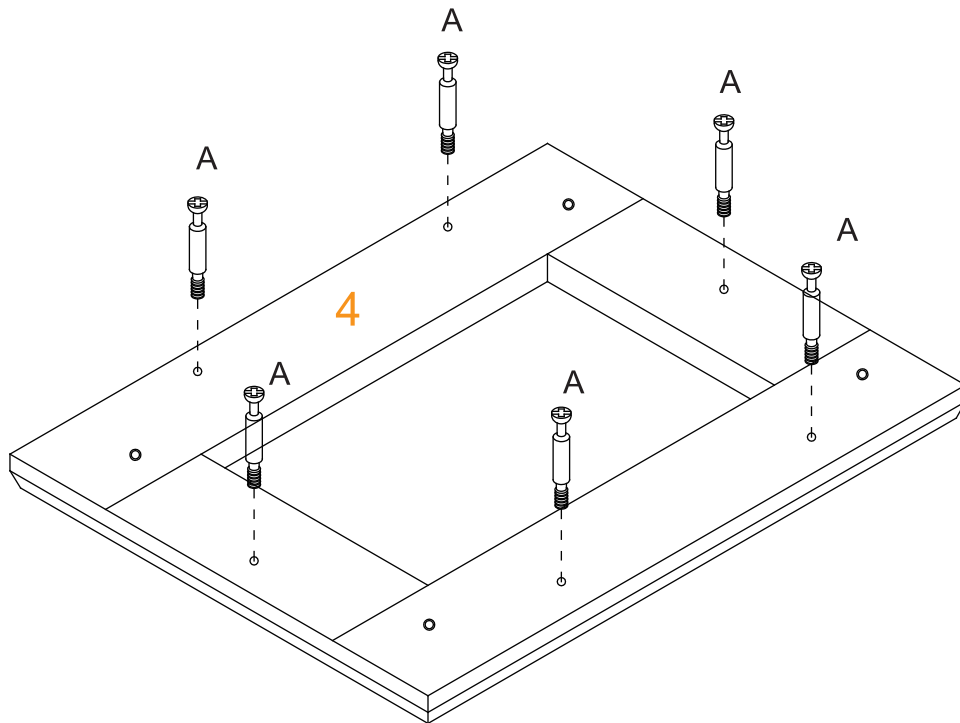
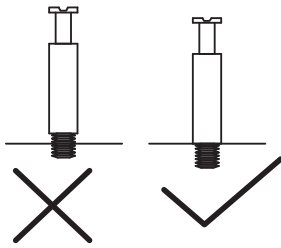
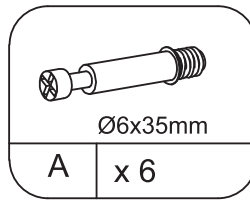
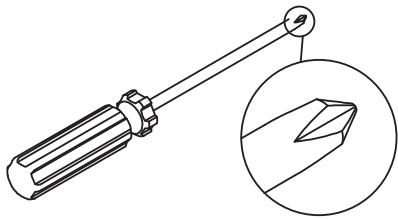

STEP 2

Please tighten the screws after completing all installation.

Por favor, apriete los tornillos después de instalar todo.

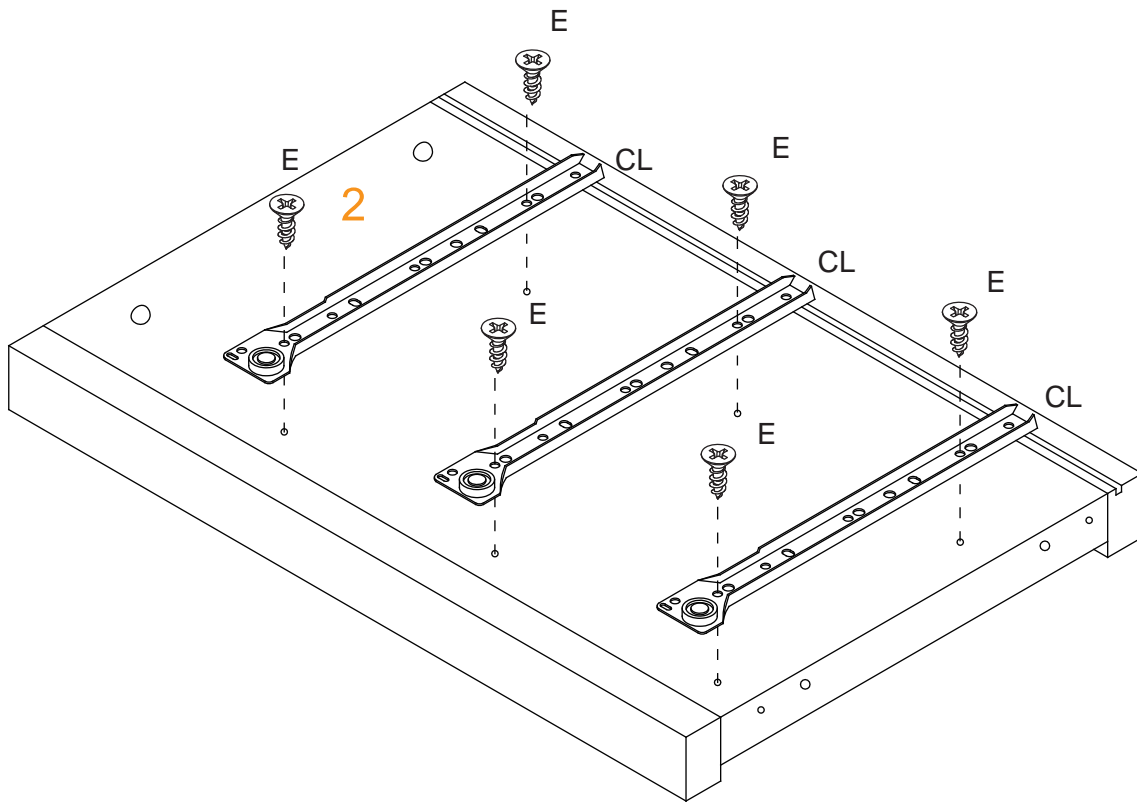
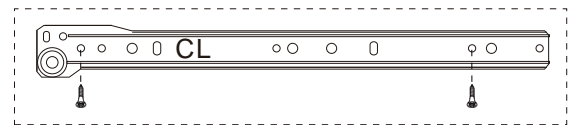
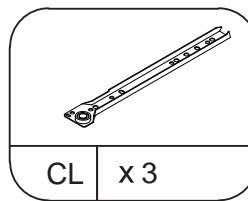
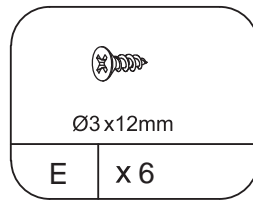
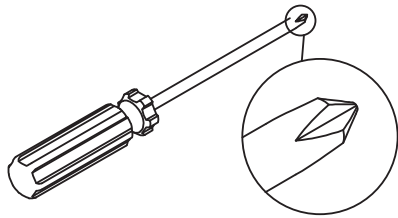

STEP 3

Please tighten the screws after completing all installation.

Por favor, apriete los tornillos después de instalar todo.

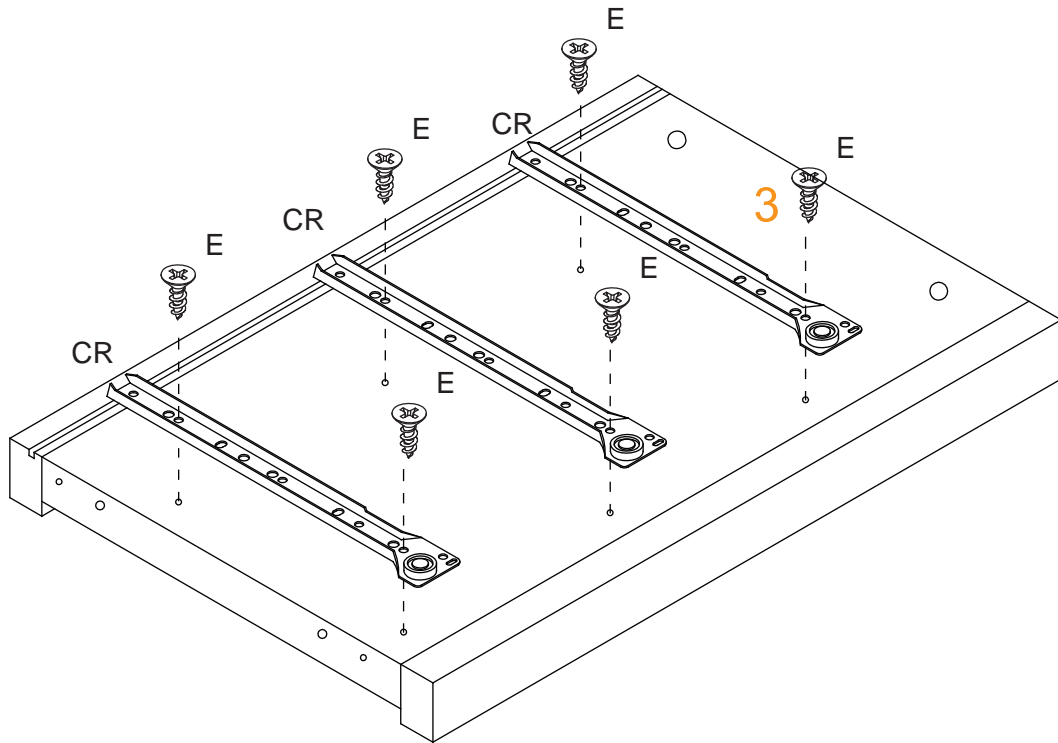
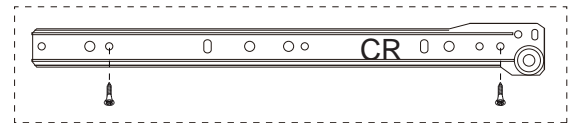
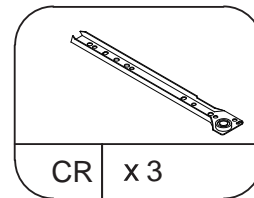
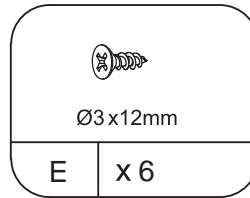
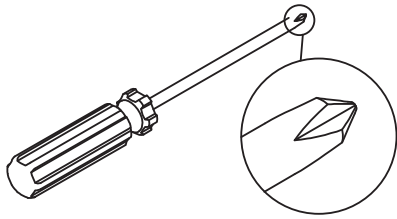

STEP 4 Please tighten the screws after completing all installation.

Por favor, apriete los tornillos después de instalar todo.

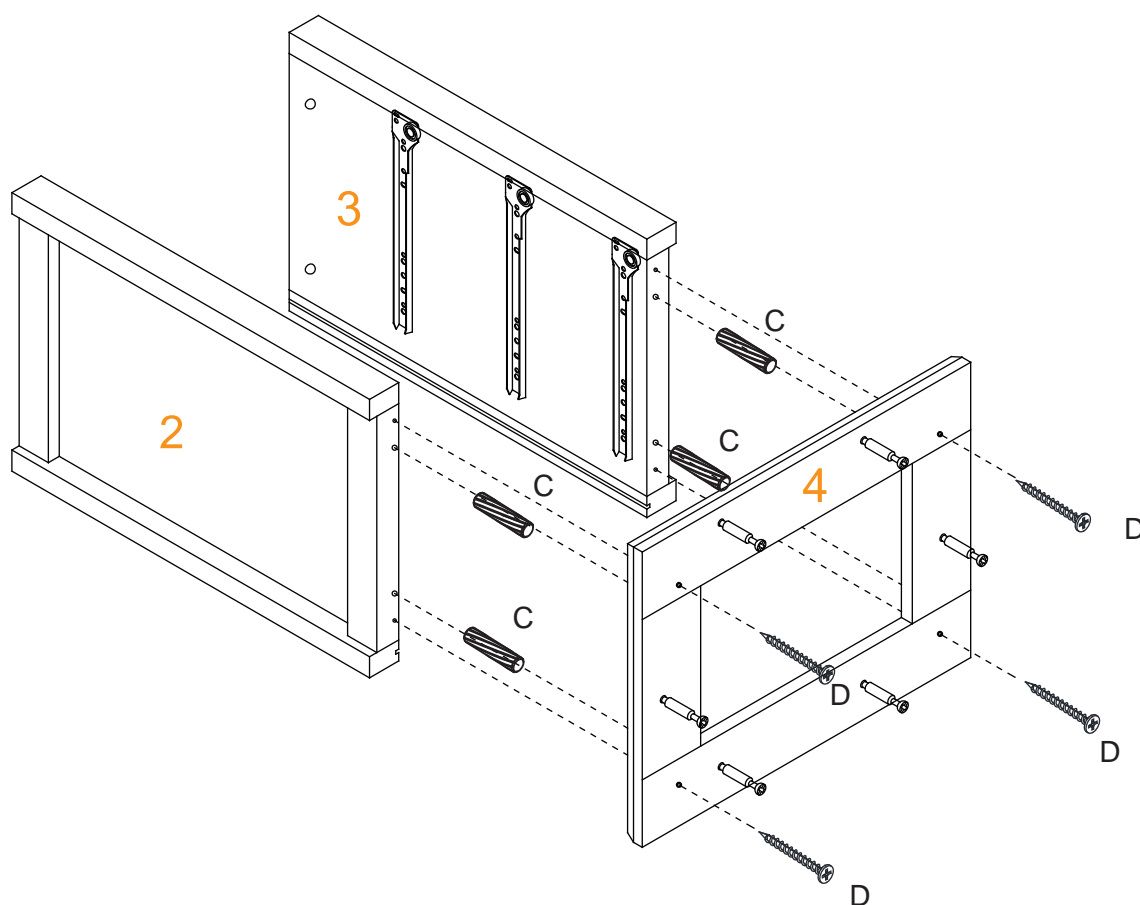
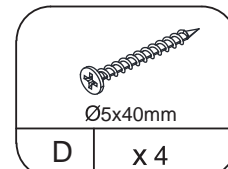
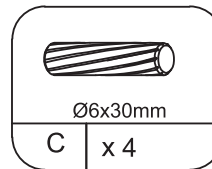
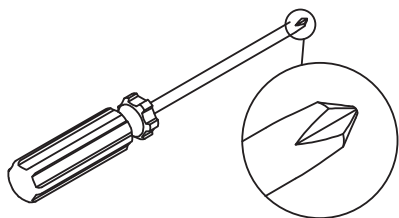

STEP 5 Please tighten the screws after completing all installation.

Por favor, apriete los tornillos después de instalar todo.

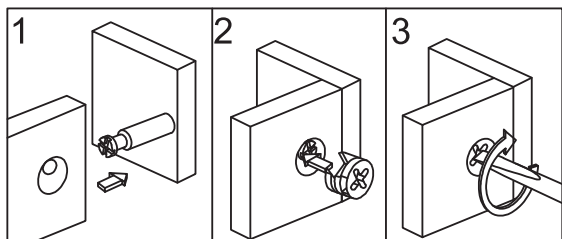
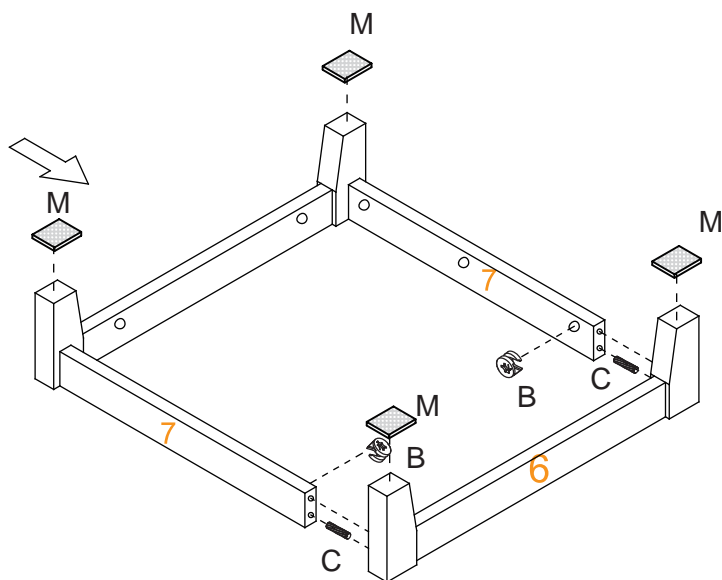
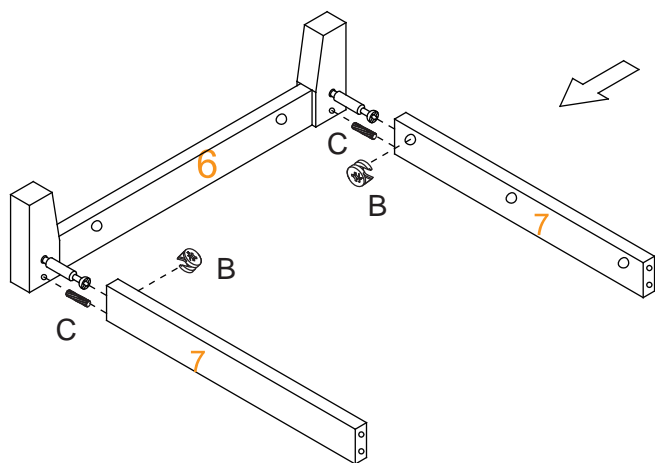
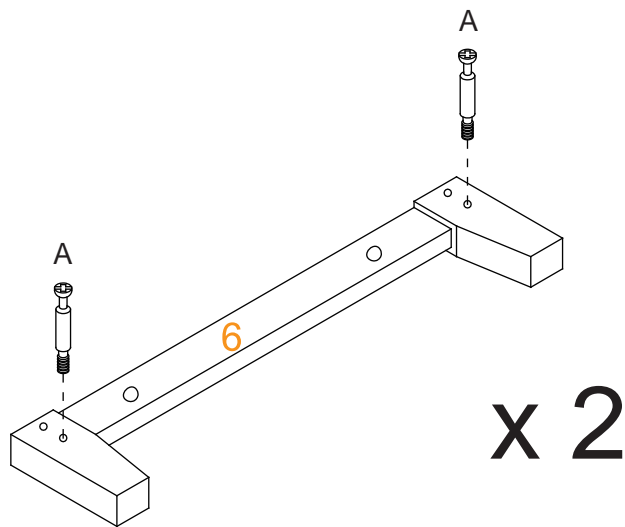
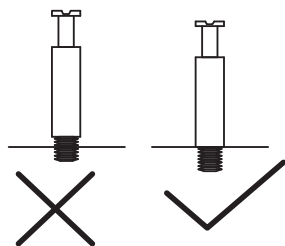
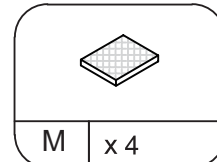
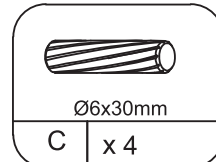
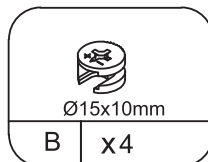
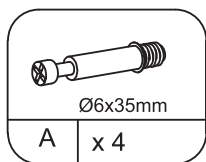
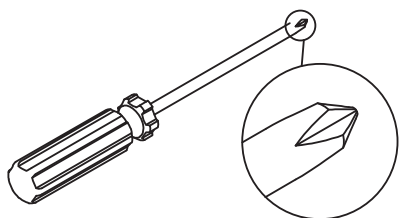

STEP 6

Please tighten the screws after completing all installation.

Por favor, apriete los tornillos después de instalar todo.

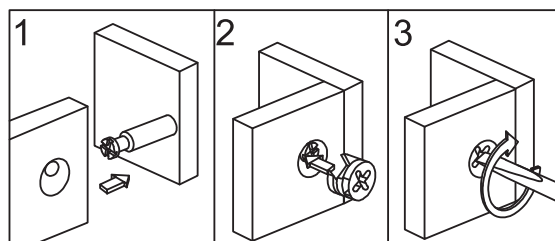
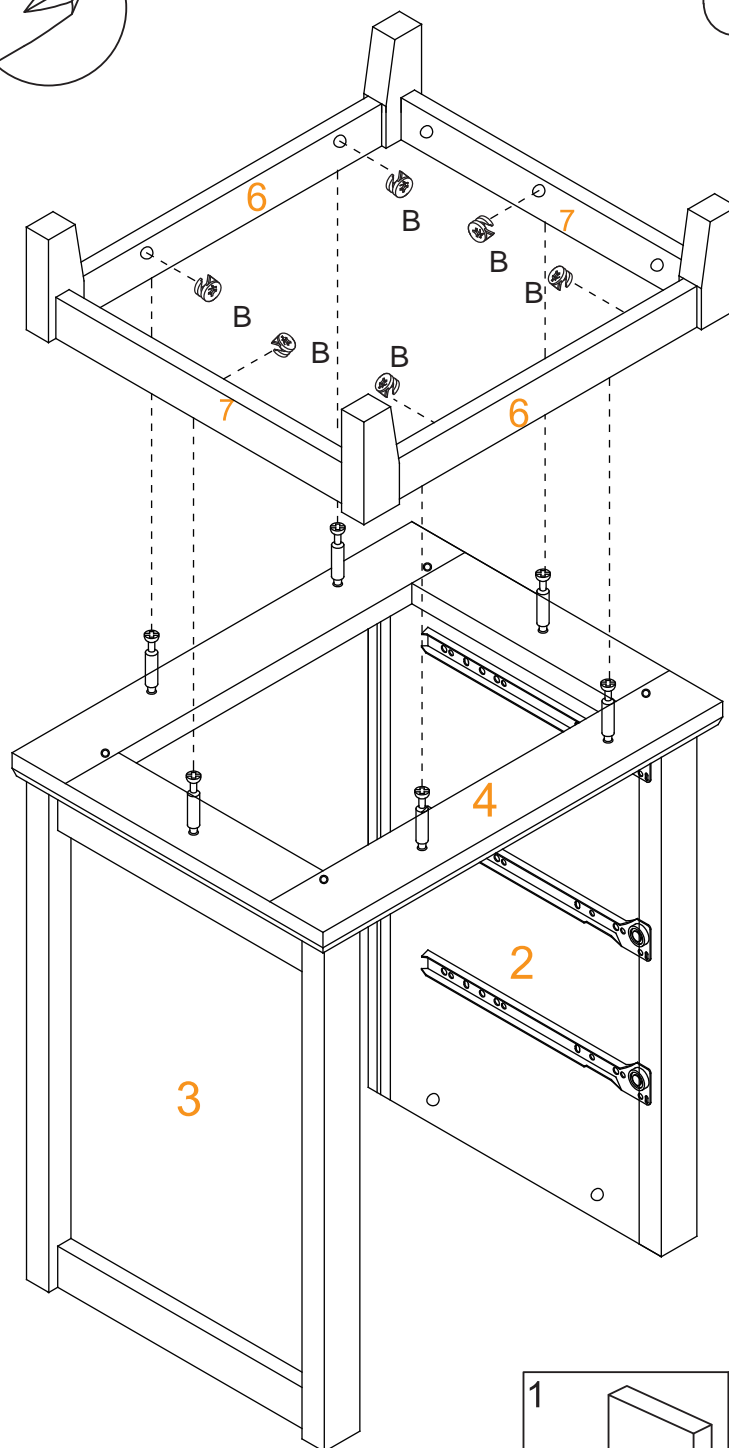
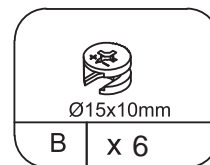
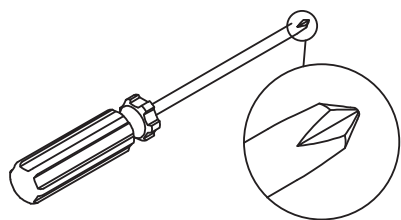

STEP 7 Please tighten the screws after completing all installation.

Por favor, apriete los tornillos después de instalar todo.

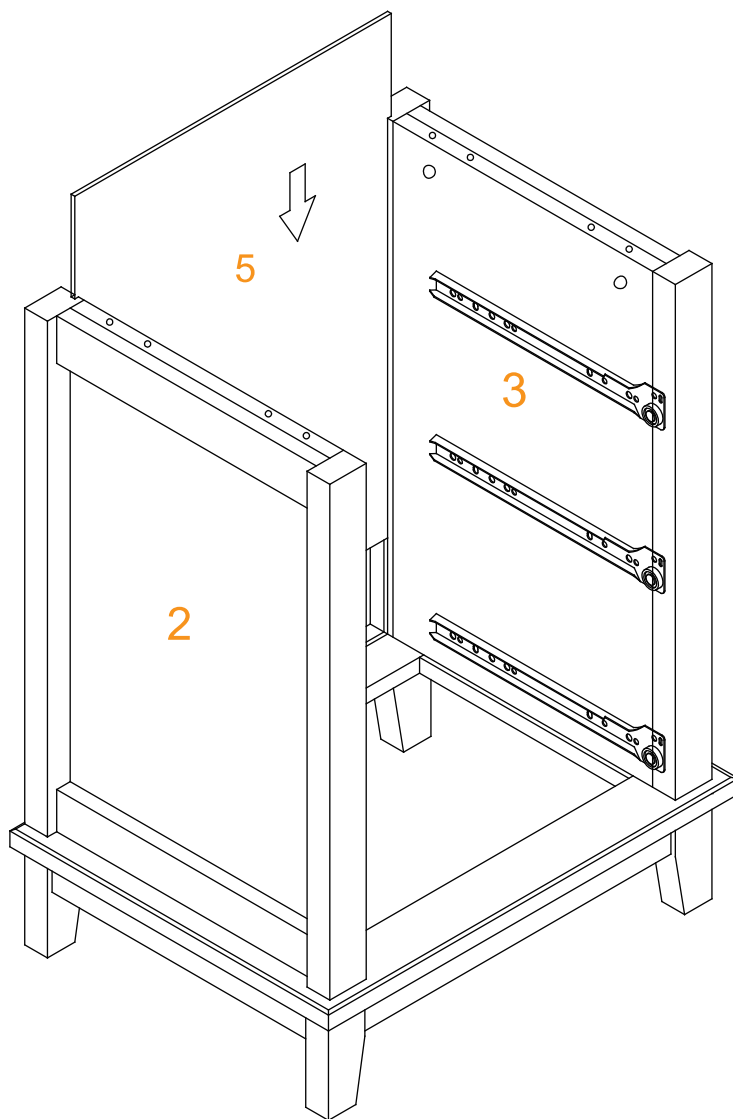

STEP 8

Please tighten the screws after completing all installation.

Por favor, apriete los tornillos después de instalar todo.

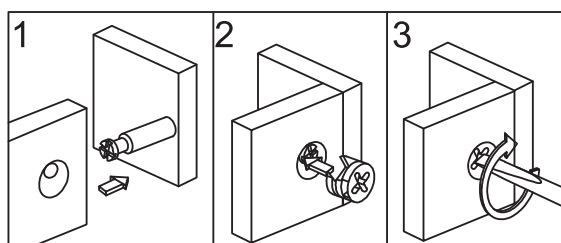
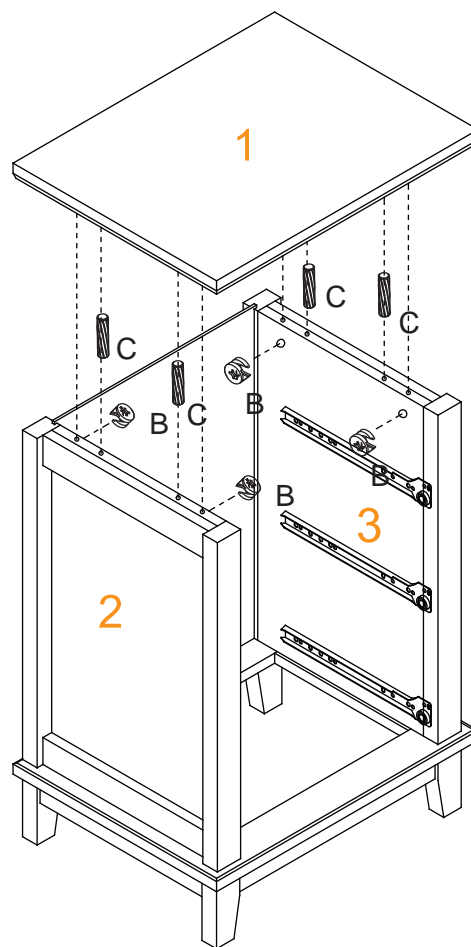
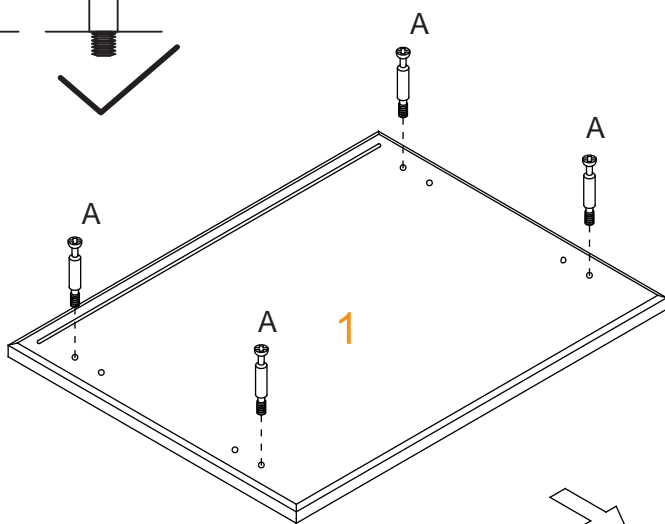
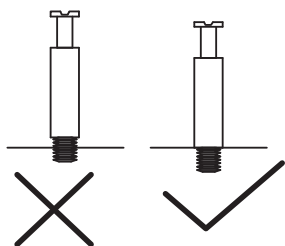
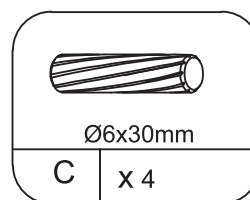
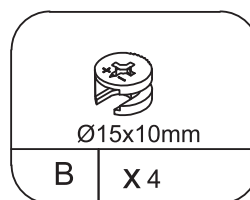
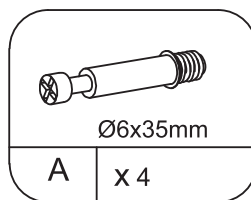
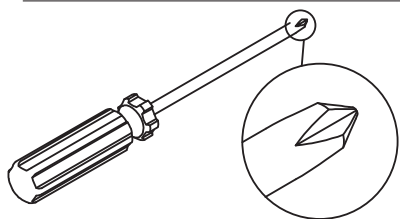

STEP 9

Please tighten the screws after completing all installation.

Por favor, apriete los tornillos después de instalar todo.

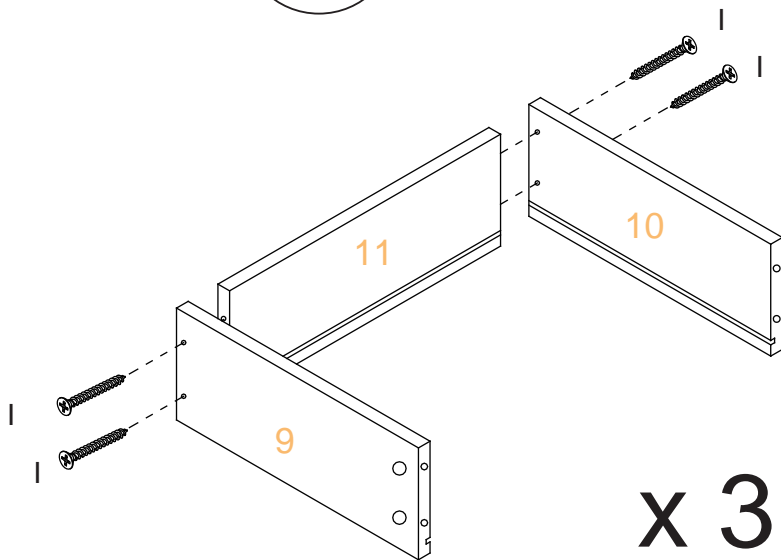
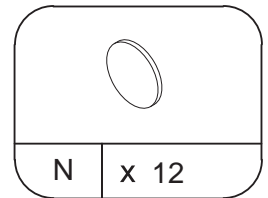
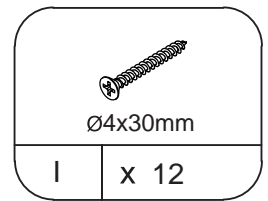
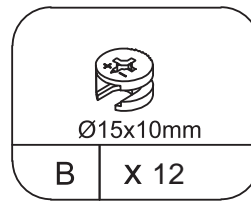
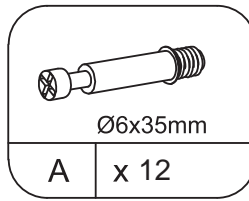
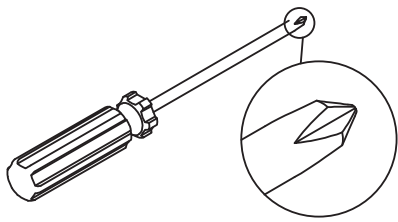

x 3

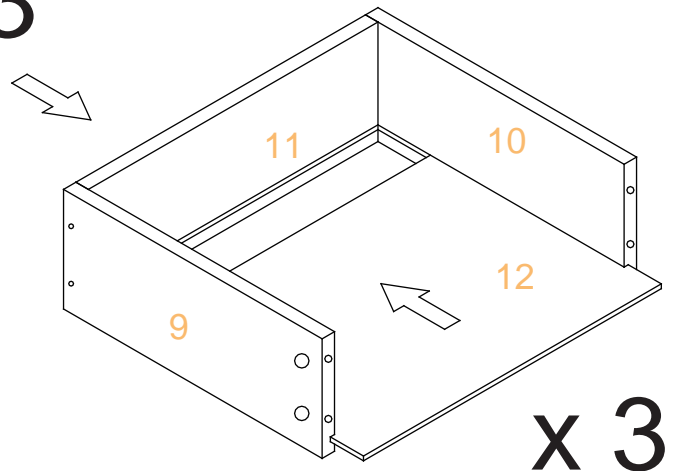

x 3

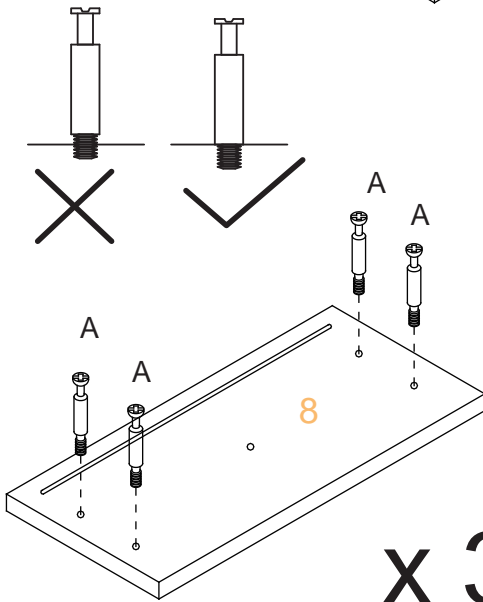

x 3

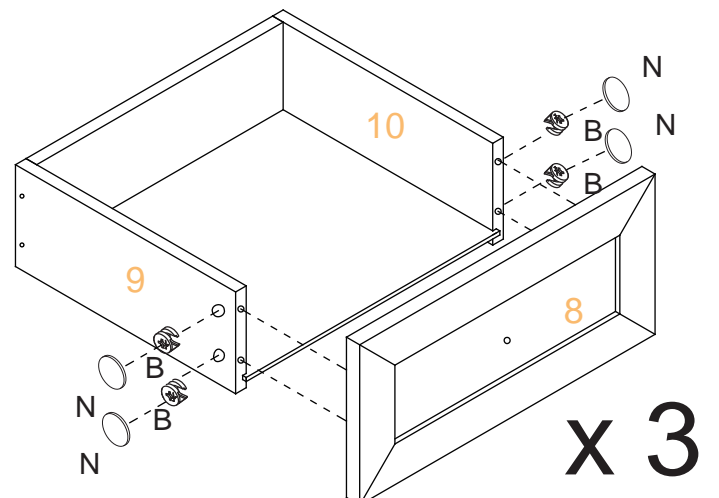
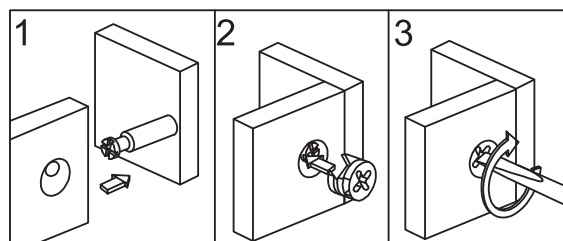

x 3

STEP 10 Please tighten the screws after completing all installation.

Por favor, apriete los tornillos después de instalar todo.

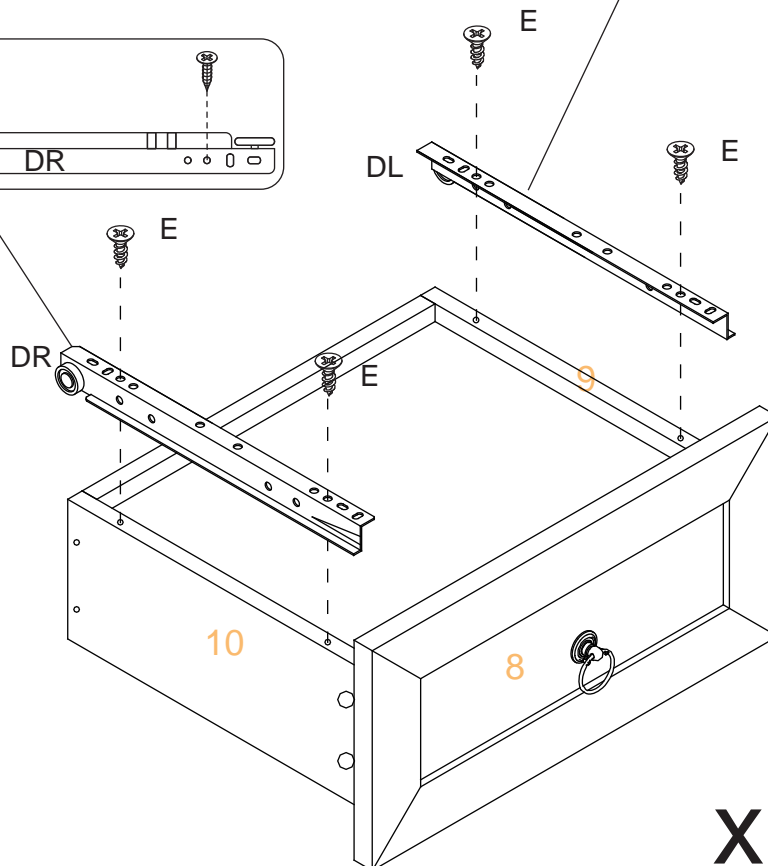
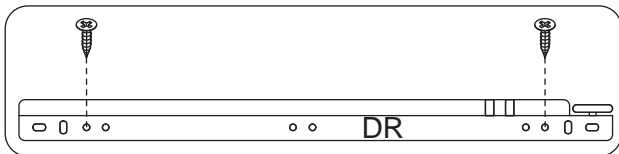
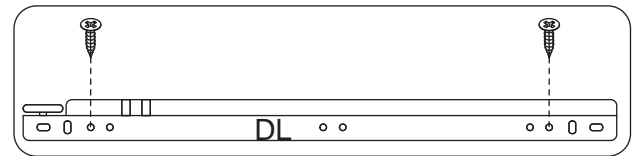
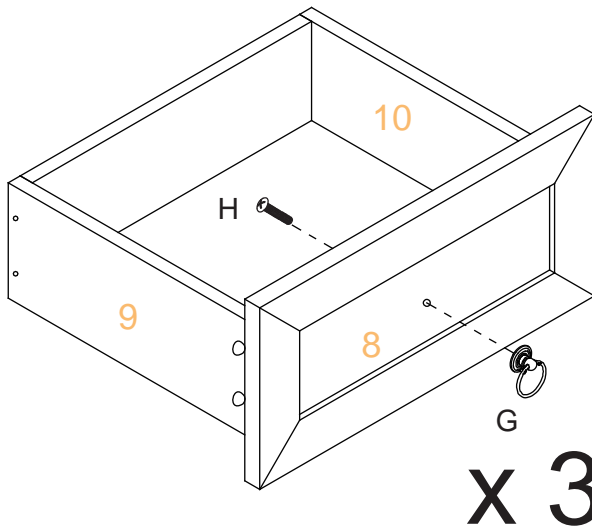
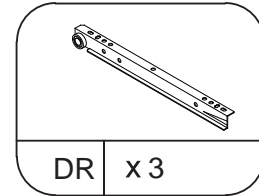
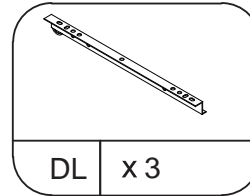
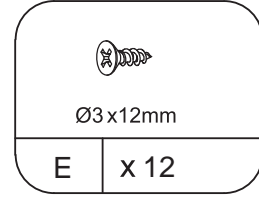
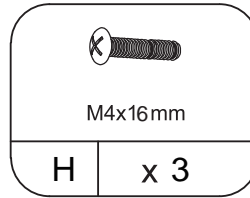
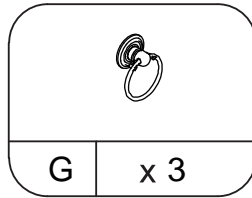
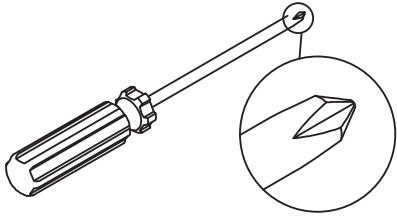

STEP 11 Please tighten the screws after completing all installation.

Por favor, apriete los tornillos después de instalar todo.

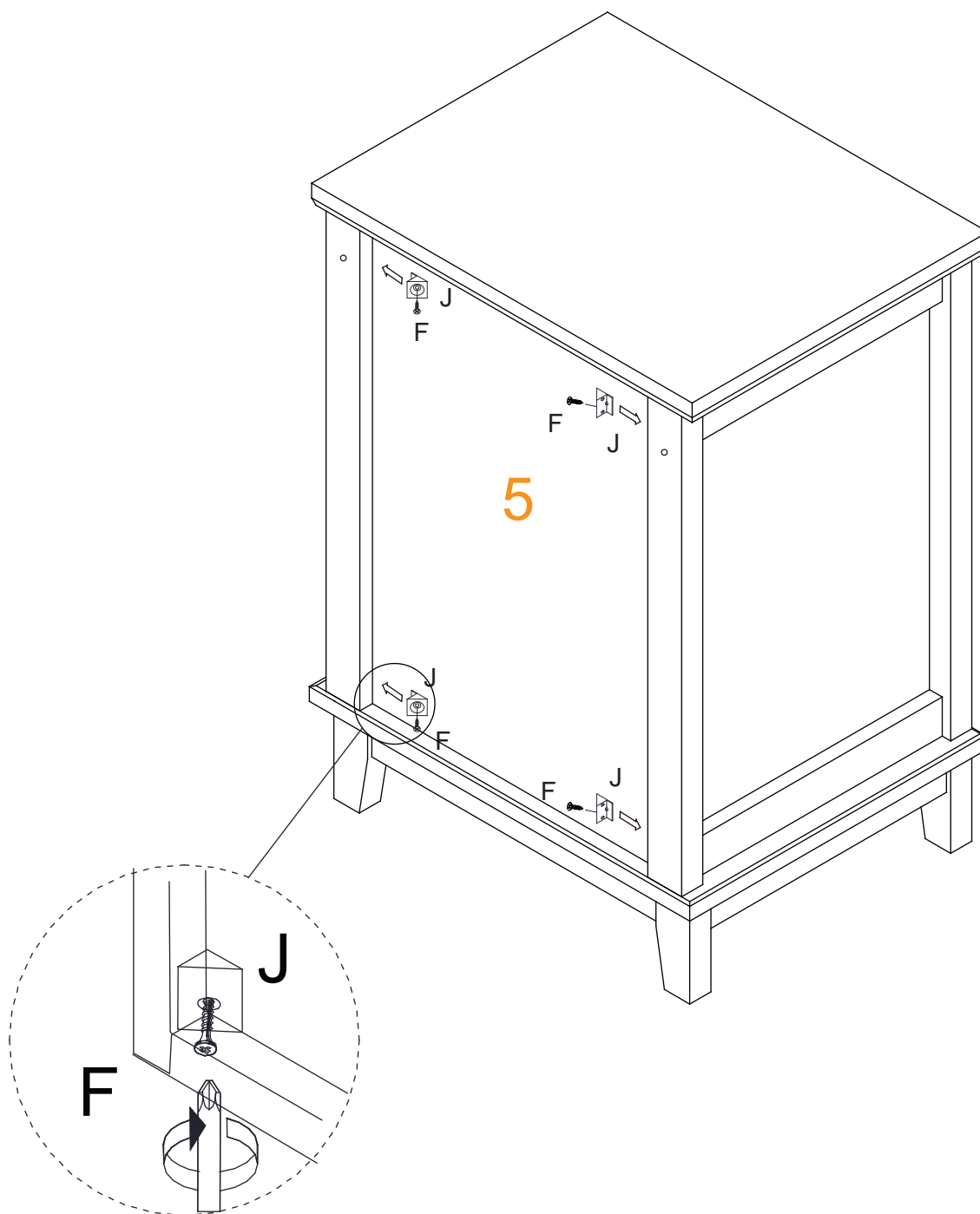
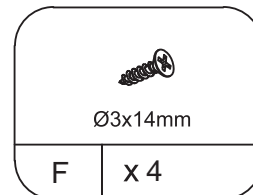
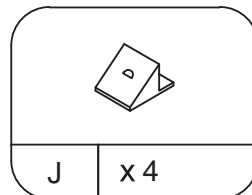
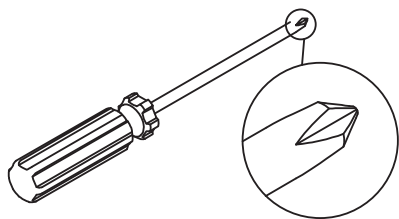

STEP 12 Please tighten the screws after completing all installation.

Por favor, apriete los tornillos después de instalar todo.

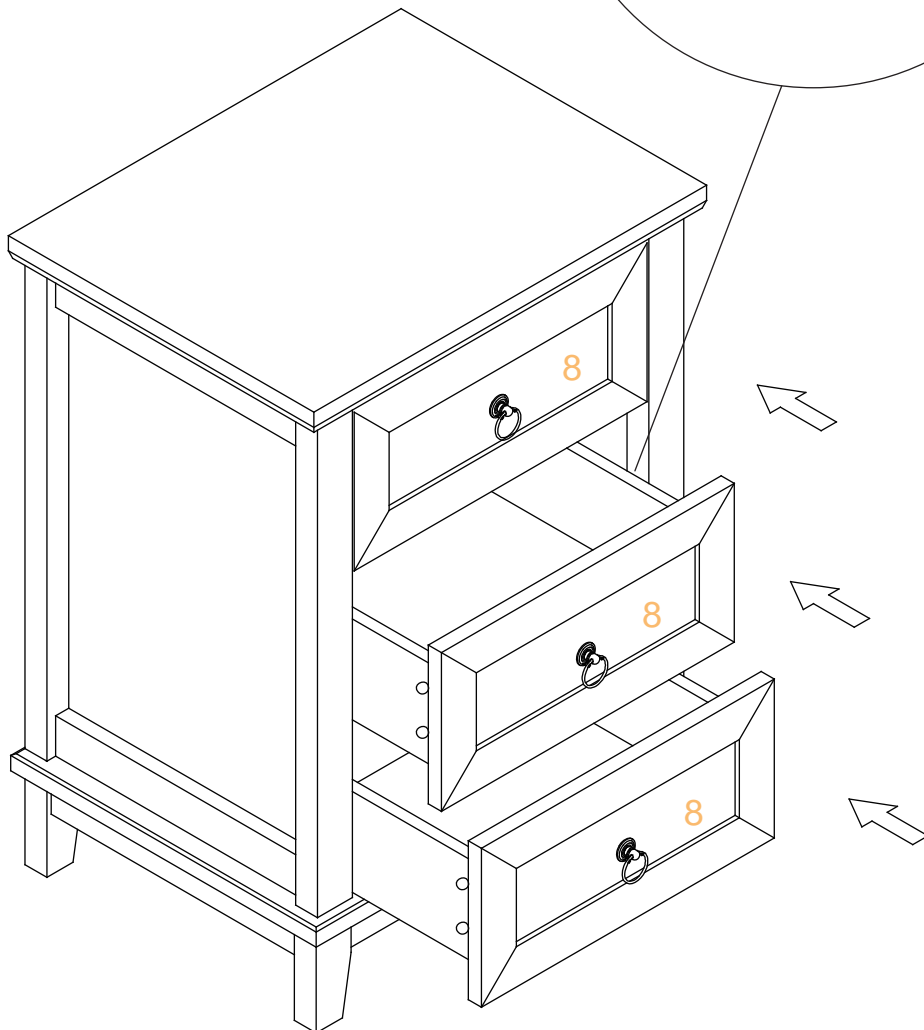
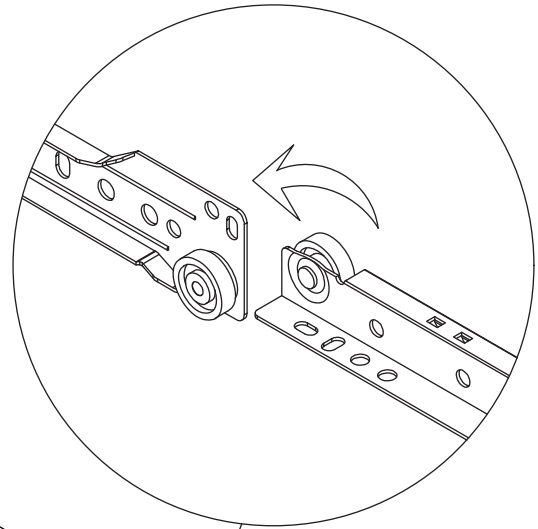
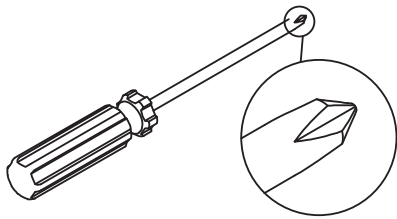

STEP 13 Please tighten the screws after completing all installation.

Por favor, apriete los tornillos después de instalar todo.

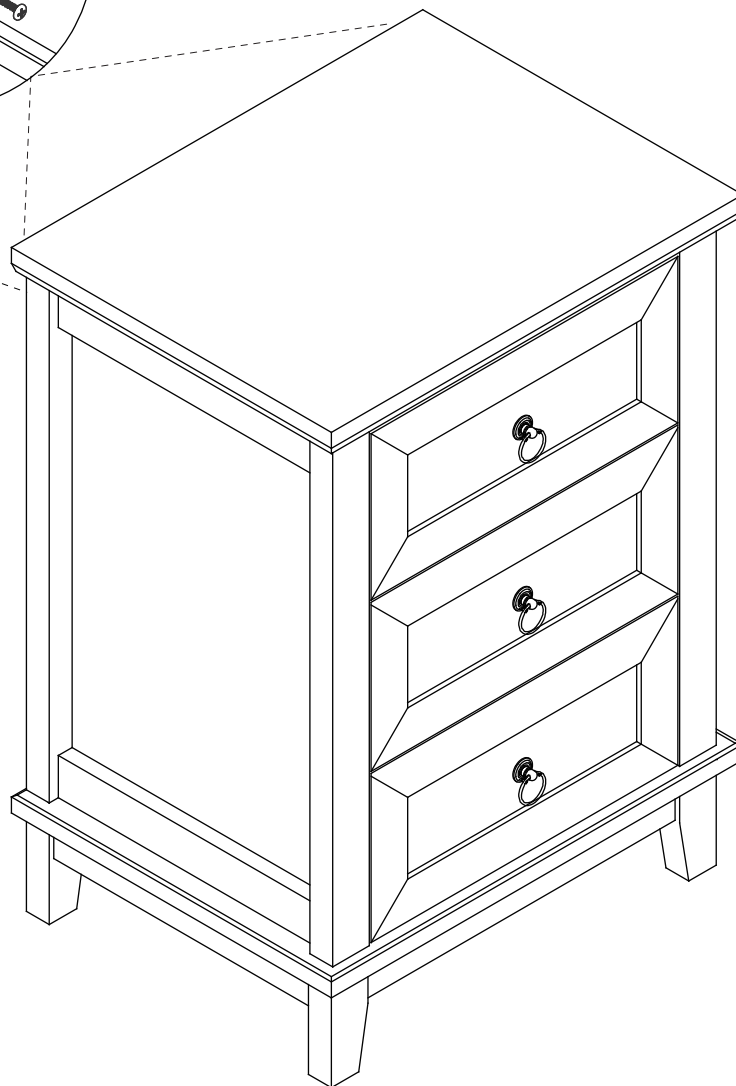
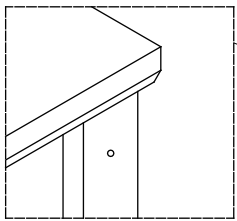
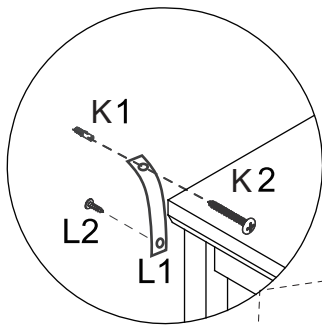
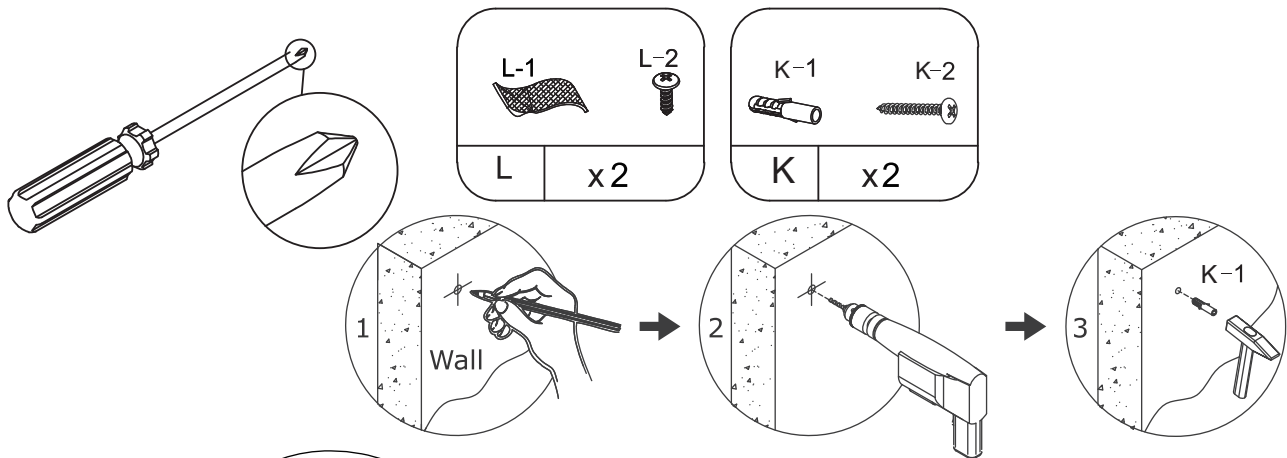



MAINTENANCE AND CARE

Prevent Moisture Damage:

Safeguard your laminate furniture by keeping it in a dry environment. Store the furniture away from damp areas and water sources.

Sunlight Shielding:

Shield your laminate furniture from direct sunlight to prevent color fading and surface deterioration. Consider using curtains or blinds for protection, especially if direct sunlight exposure is unavoidable.

Regular Care:

Maintain your laminate furniture's appearance by gently wiping surfaces with a damp cloth. Avoid using overly wet cloths or abrasive cleaning tools.

Avoid Scratches:

Protect the furniture surface from scratches by refraining from placing sharp or hard objects on it. When moving the furniture, be cautious not to scrape the legs against the floor.

Proper Weight Distribution:

Prevent structural damage by placing heavy objects on stable support surfaces rather than directly on the laminate furniture's surface. This simple step can prolong the life of your furniture.

Evite daños por humedad:

Proteja sus muebles laminados manteniéndolos en un ambiente seco. Guarde los muebles lejos de zonas húmedas y fuentes de agua.

Protéjalos de la luz solar:

Proteja sus muebles laminados de la luz solar directa para evitar la pérdida de color y el deterioro de la superficie. Considere el uso de cortinas o persianas como protección, especialmente si la exposición directa a la luz solar es inevitable.

Cuidado regular:

Mantenga el aspecto de sus muebles laminados limpiando suavemente las superficies con un paño húmedo. Evite utilizar paños demasiado húmedos o herramientas de limpieza abrasivas.

Evite los arañazos:

Proteja la superficie del mueble de arañazos evitando colocar objetos afilados o duros sobre ella. Al mover el mueble, tenga cuidado de no raspar las patas contra el suelo.

Distribución adecuada del peso:

Evite daños estructurales colocando objetos pesados sobre superficies de apoyo estables en lugar de directamente sobre la superficie del mueble laminado. Este sencillo paso puede prolongar la vida de sus muebles.



WARRANTY INFORMATION

Warranty Coverage: Our warranty provides protection against manufacturing defects in materials and workmanship for a specified period from the date of purchase, as outlined in the accompanying warranty documentation.

Exclusions: The warranty does not cover damages resulting from misuse, negligence, accidents, normal wear and tear, unauthorized repairs or modifications, improper assembly, or failure to adhere to the care and maintenance guidelines provided.

WARRANTY CLAIM PROCESS

To initiate a return, please follow these steps:

1. Log into your account and go to the "Your Orders" section.
2. Locate the order containing the item you wish to return.
3. Contact our customer service for assistance in obtaining a prepaid return label.
4. Once you receive the return label, securely affix it to the package.
5. You can then choose to drop off the package at a designated carrier location or arrange for a pickup.
6. After we receive and inspect the returned product, we will initiate the refund process.
7. The refund will be credited back to the original payment method used during the purchase.
8. Typically, refunds are processed within 3-5 business days.

Cobertura de la garantía: Nuestra garantía proporciona protección contra defectos de fabricación en materiales y mano de obra durante un período determinado a partir de la fecha de compra, como se indica en la documentación de garantía adjunta.

Exclusiones: La garantía no cubre los daños resultantes de uso indebido, negligencia, accidentes, desgaste normal, reparaciones o modificaciones no autorizadas, montaje incorrecto o incumplimiento de las directrices de cuidado y mantenimiento proporcionadas. las directrices de cuidado y mantenimiento proporcionadas.

PROCESO DE RECLAMACIÓN DE LA GARANTÍA

Para iniciar una devolución siga estos pasos:

1. Accede a tu cuenta y ve a la sección "Tus pedidos"
2. Localiza el pedido que contiene el artículo que deseas devolver
3. Ponte en contacto con nuestro servicio de atención al cliente para que te ayuden obtener una etiqueta de devolución prepagada.
4. Una vez que reciba la etiqueta de devolución, fíjela firmemente al paquete
5. A continuación, puede optar por depositar el paquete en el lugar designado por transportista o solicitar que lo recojan.
6. Después de que recibamos e inspeccionemos el producto devuelto, iniciaremos proceso de reembolso.
7. El reembolso se abonará de nuevo al método de pago original utilizado durante compra.
8. Normalmente, los reembolsos se procesan en un plazo de 3 a 5 días laborables.