

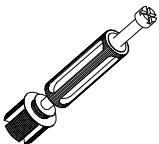

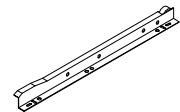







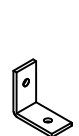
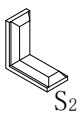

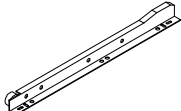
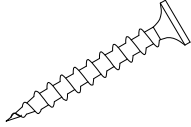
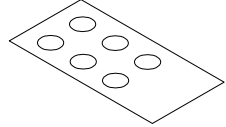
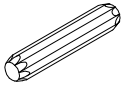
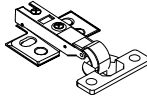
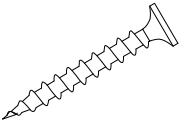
<p>A</p>  <p>55PCS</p>	<p>G</p> <p>300MM</p>  <p>3PCS</p>	<p>M</p> <p>3.5*14</p>  <p>38PCS</p>	<p>S</p>  <p>S₁</p>  <p>S₂</p> <p>2PCS</p>
<p>B</p>  <p>55PCS</p>	<p>H</p> <p>300MM</p>  <p>3PCS</p>	<p>N</p> <p>3.5*35</p>  <p>12PCS</p>	<p>T</p>  <p>6PCS</p>
<p>C</p> <p>8*40</p>  <p>29PCS</p>	<p>I</p>  <p>2PCS</p>	<p>O</p> <p>4*50</p>  <p>2PCS</p>	
<p>D</p> <p>7*50</p>  <p>10PCS</p>	<p>J</p>  <p>4PCS</p>	<p>P</p> <p>128MM</p>  <p>4PCS</p>	
<p>E</p> <p>300MM</p>  <p>3PCS</p>	<p>K</p>  <p>52PCS</p>	<p>Q</p> <p>4*19</p>  <p>8PCS</p>	
<p>F</p> <p>300MM</p>  <p>3PCS</p>	<p>L</p>  <p>7PCS</p>	<p>R</p>  <p>2PCS</p>	

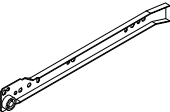
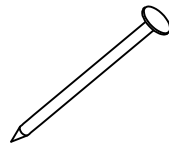

16

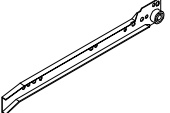

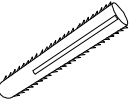
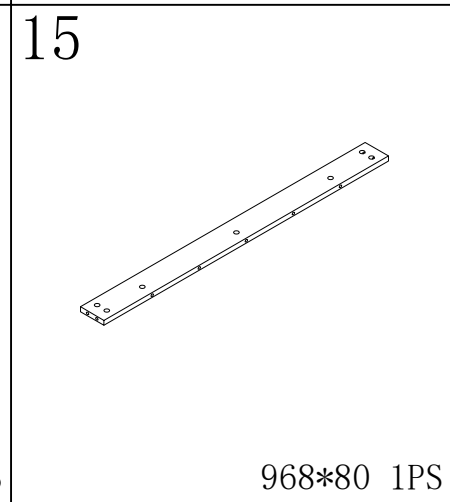
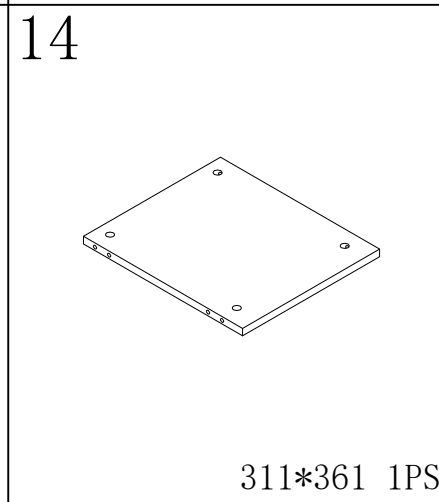
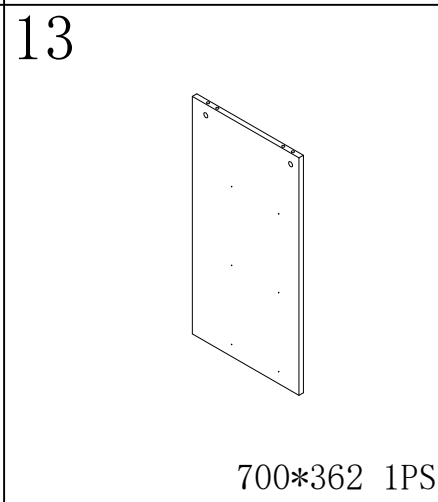
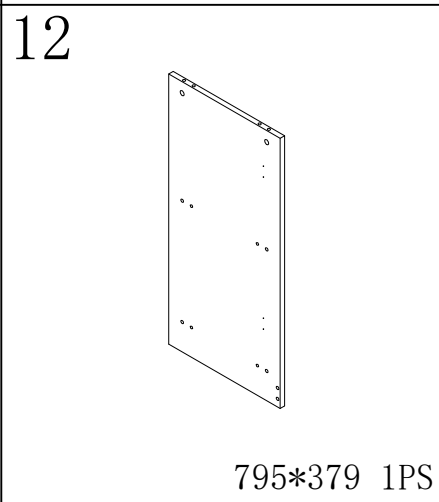
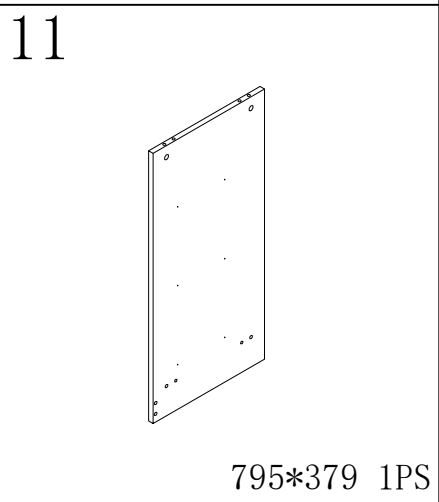
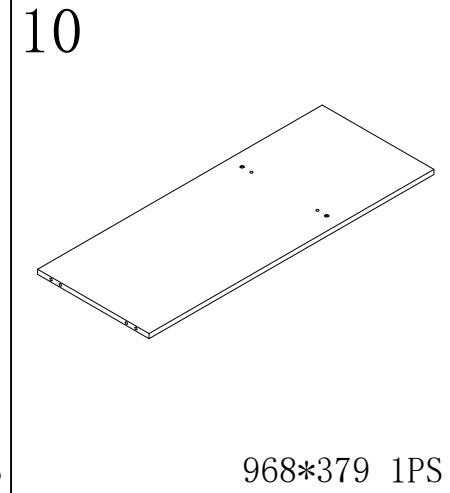
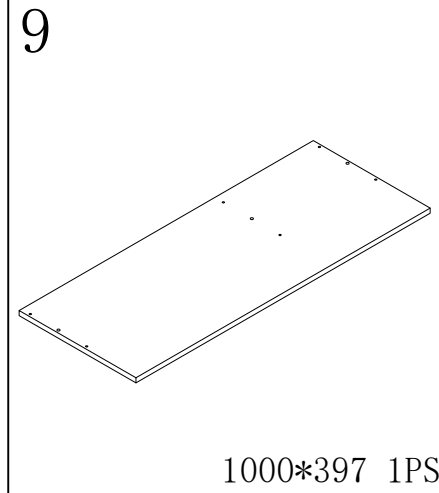
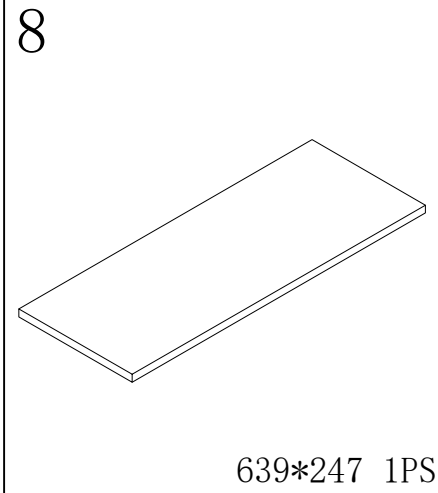
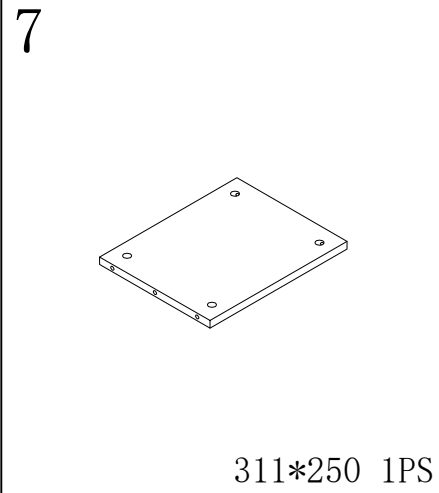
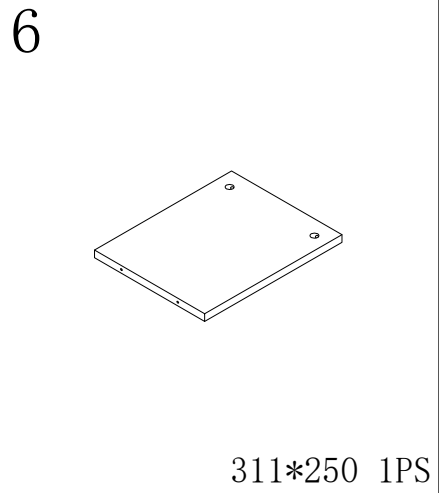
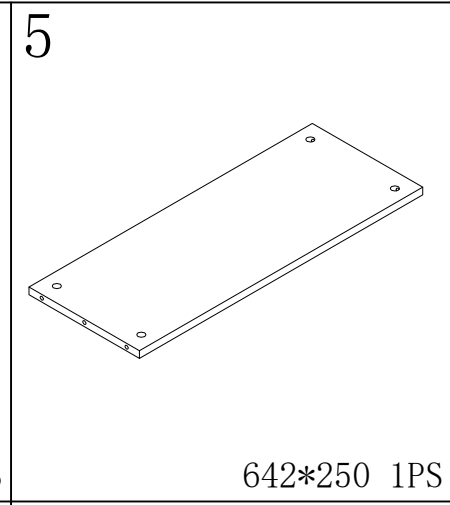
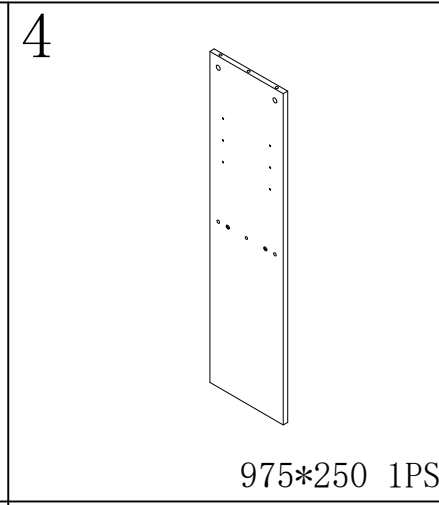
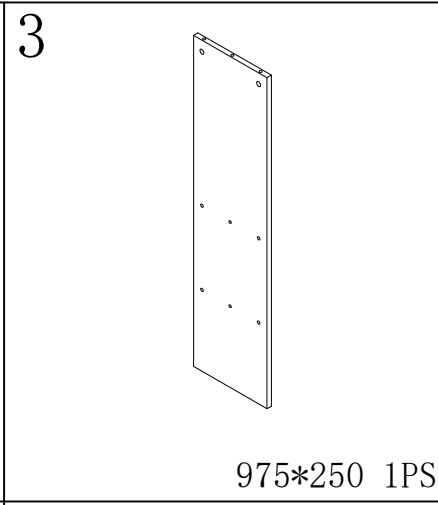
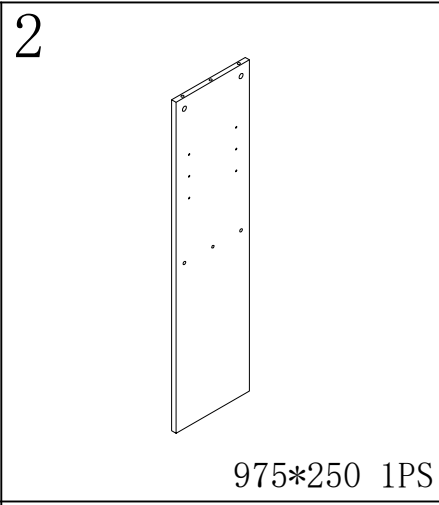
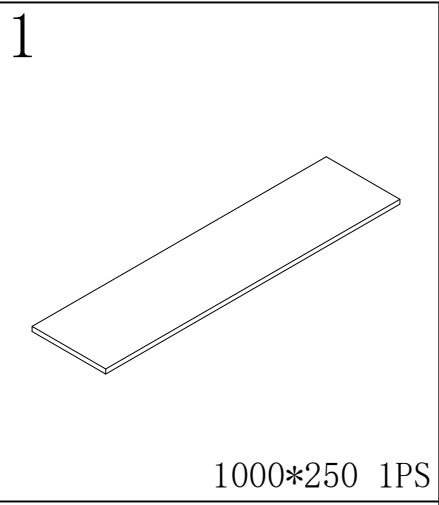
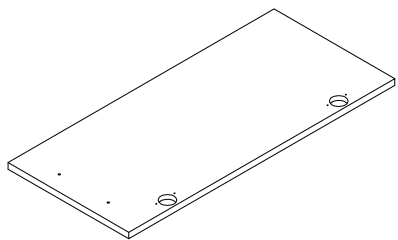
696*316 1PS

17

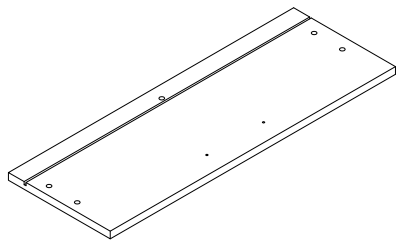

647*231 3PS

18

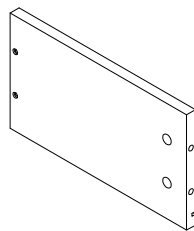

300*170 3PS

19

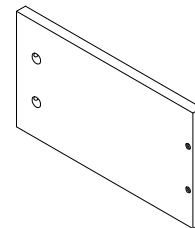

300*170 3PS

20

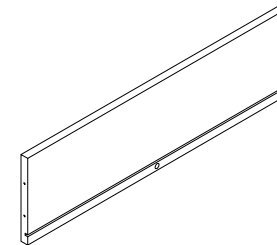

586*170 3PS

21

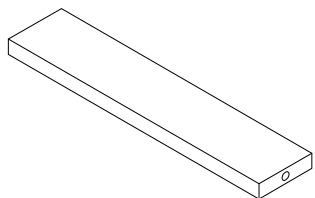

284*60 3PS

22

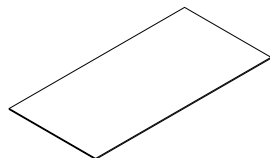

596*294 3PS

23



996*332 1PS

24

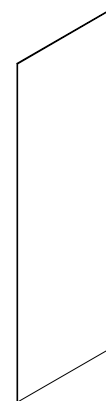

996*332 2PS

25



722*332 3PS



Hardware installation demonstration

NOTE: Please make sure "A" hardware tightened and can't be pulled out!

I

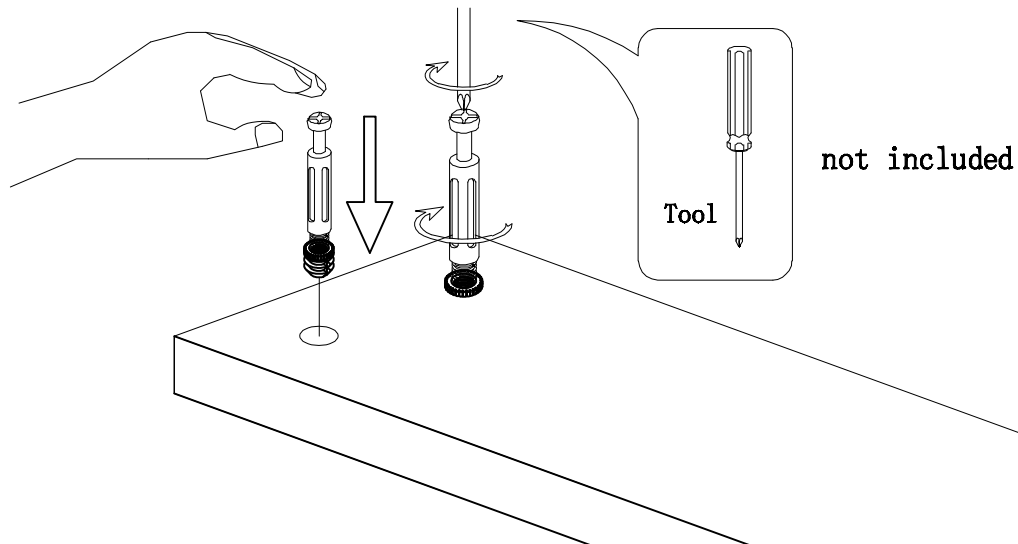

II

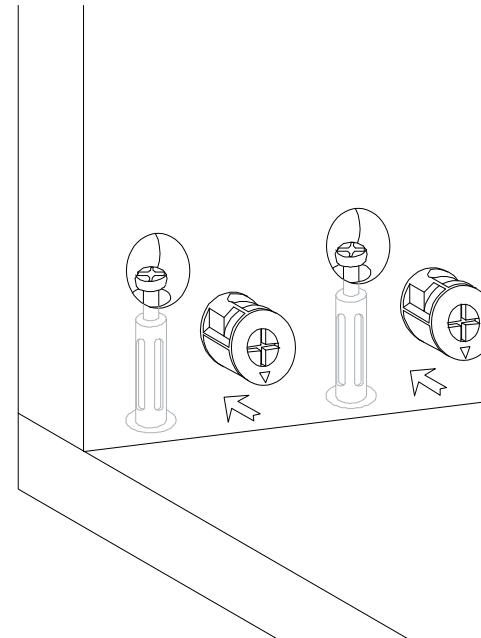

III

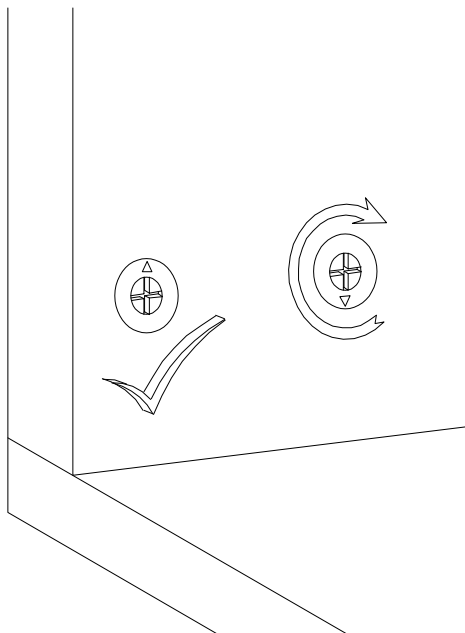

IV



Scan QR code for assembly video



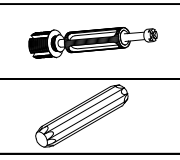
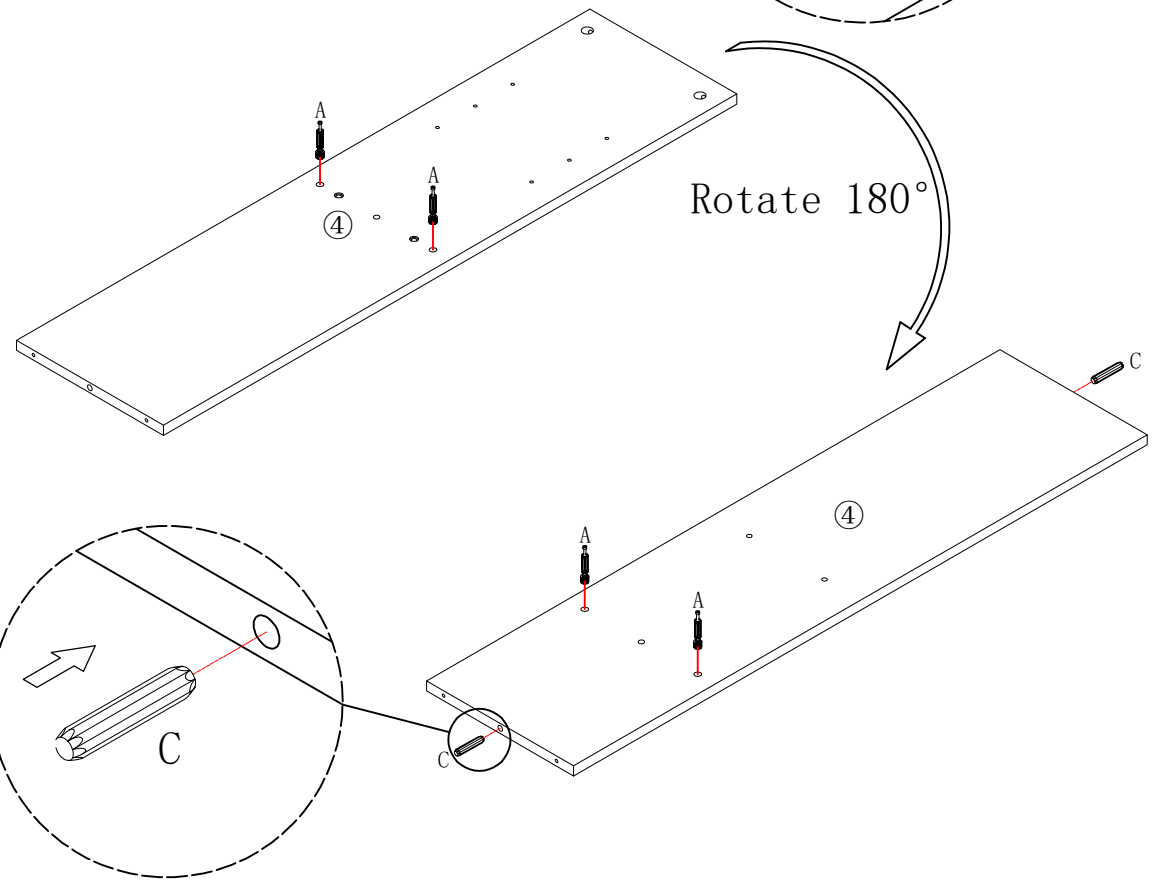
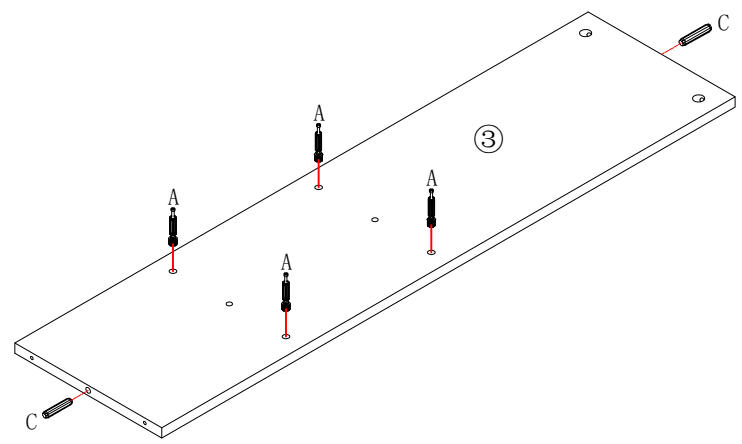
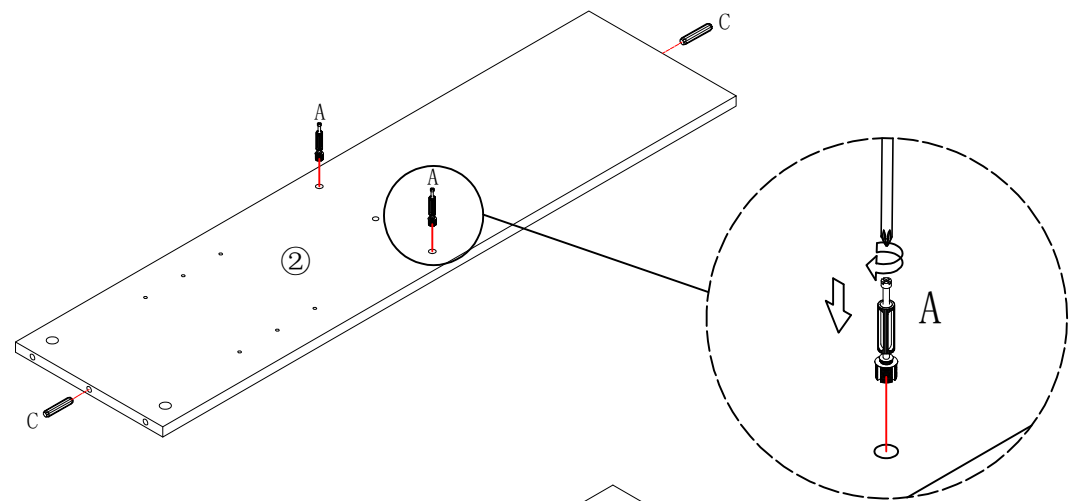
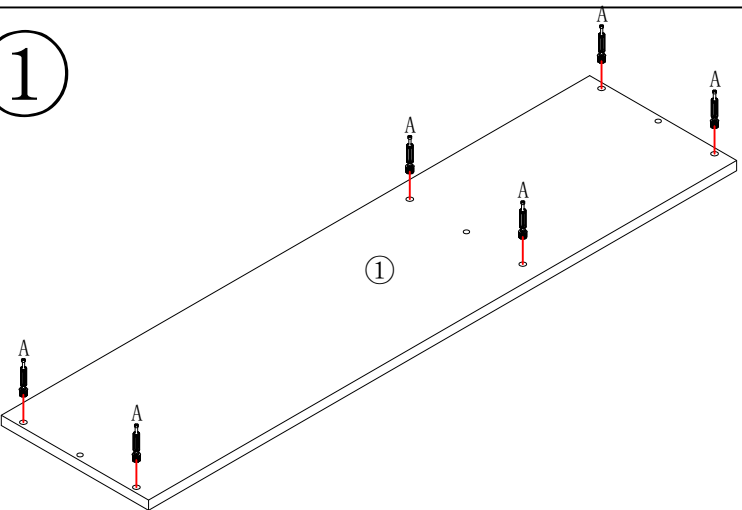

1

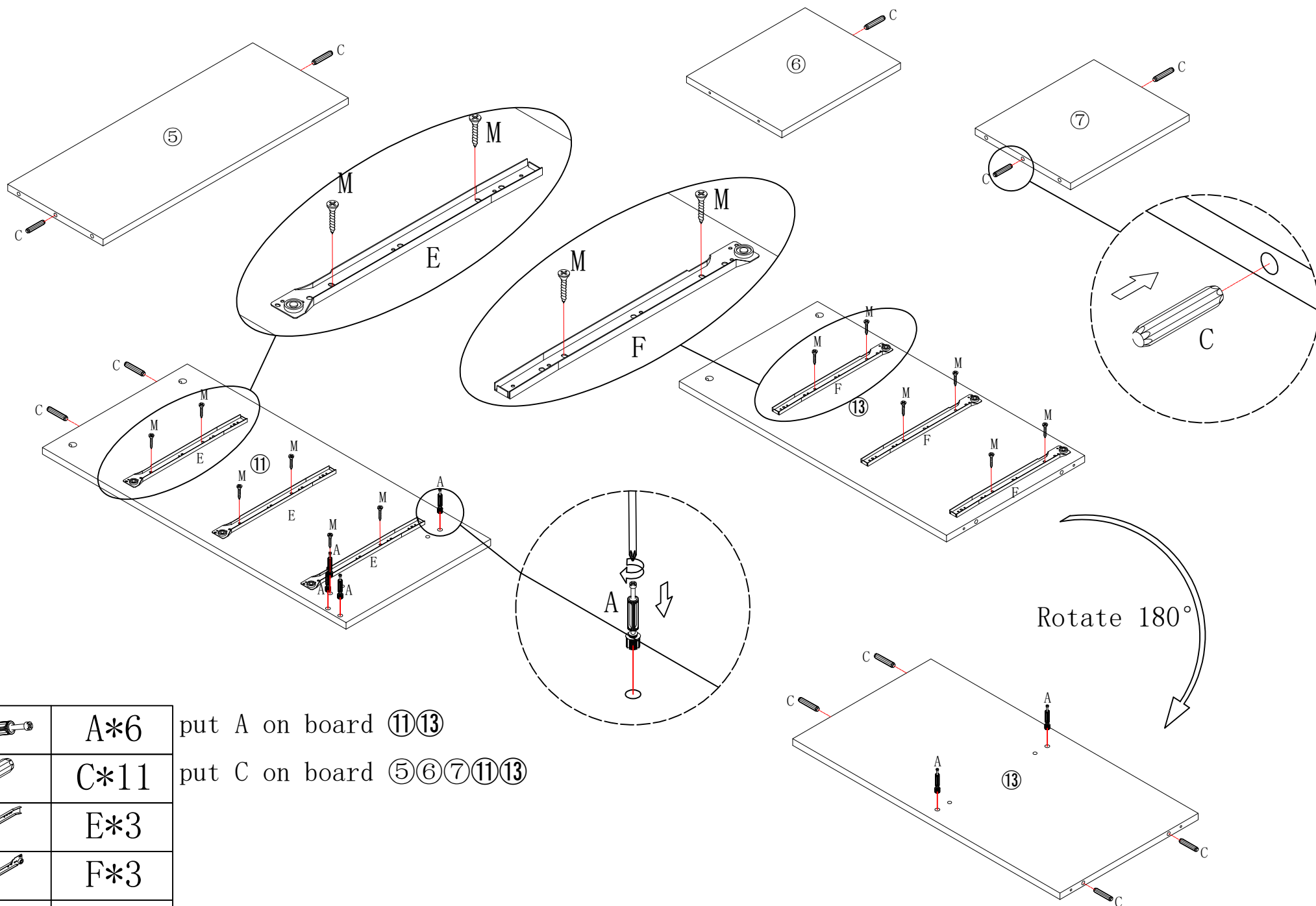

A*16 put A on board ①②③④
C*6 put C on board ②③④

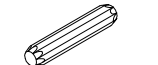
2



	A*6
	C*11
	E*3
	F*3
	M*12

put A on board ⑪⑬
 put C on board ⑤⑥⑦⑪⑬

Rotate 180°

3

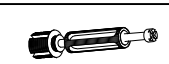
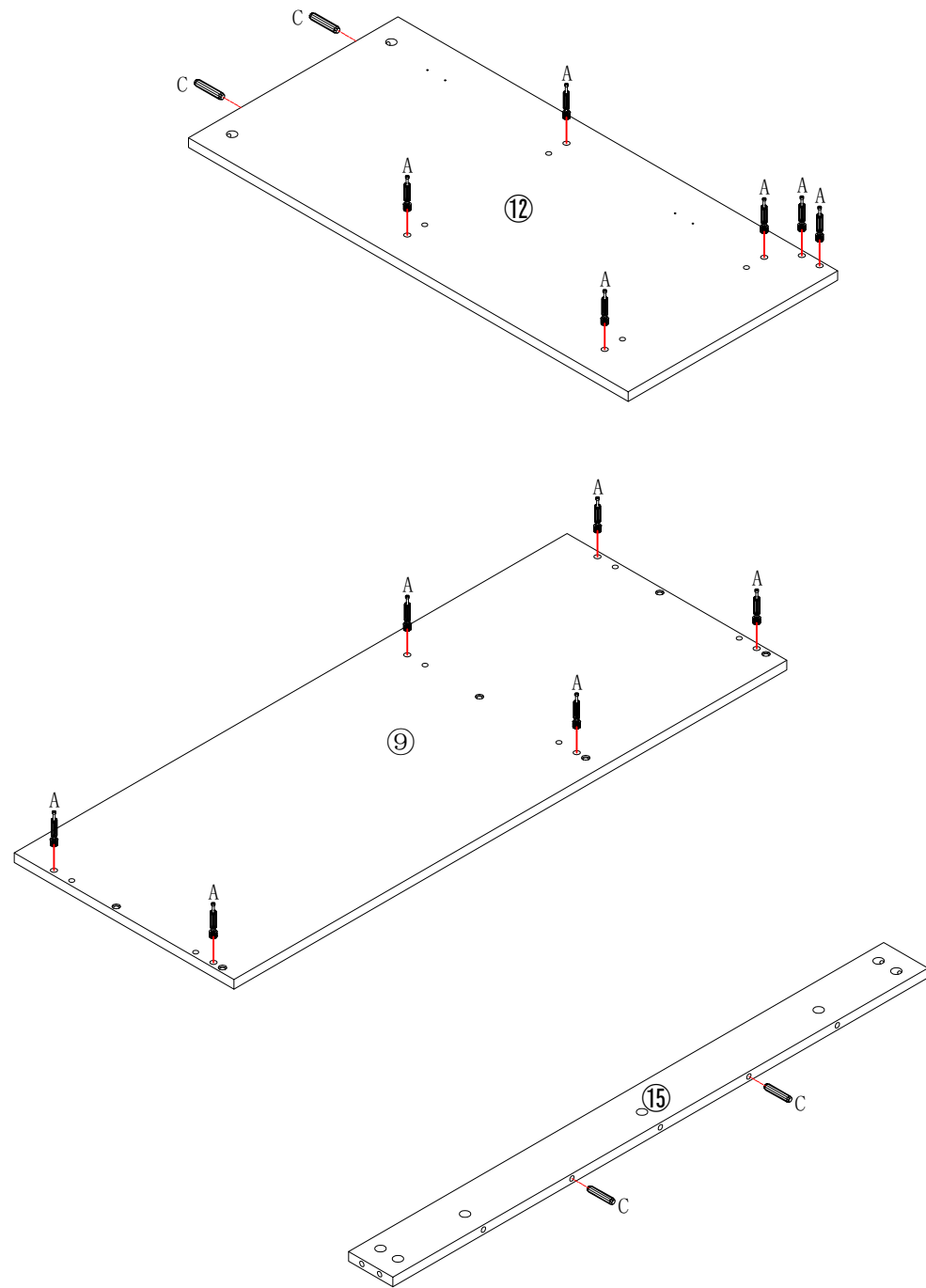
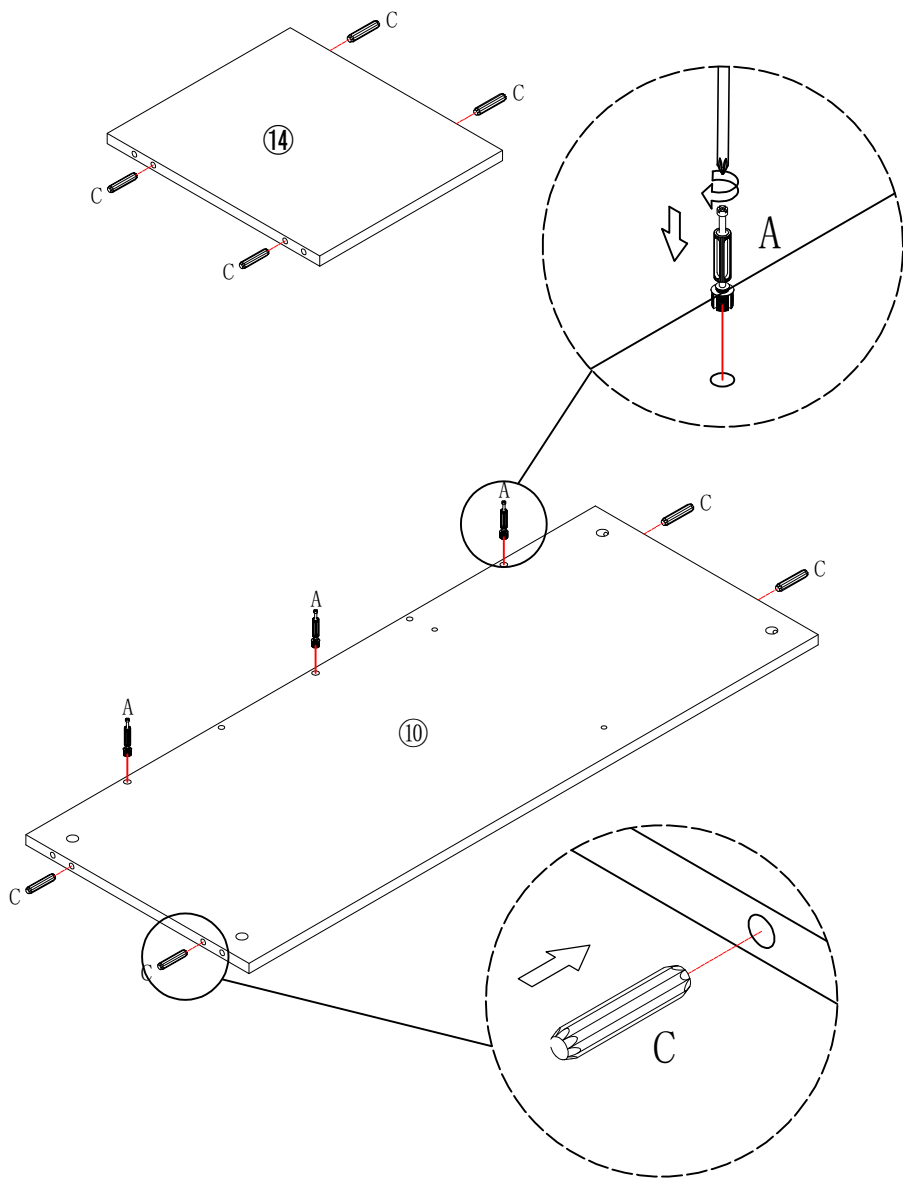

A*15 put A on board ⑨⑩⑫

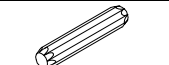

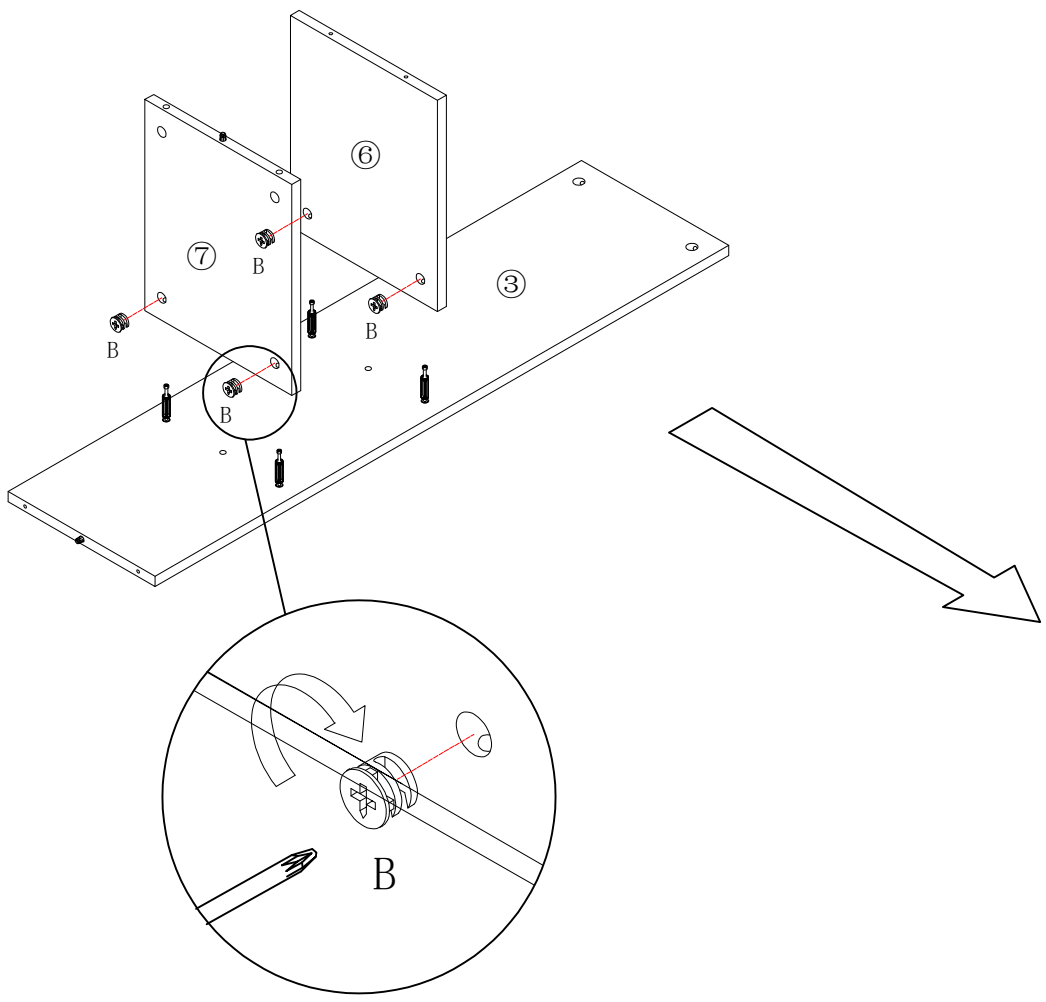

C*12 put C on board ⑩⑫⑭⑮

4

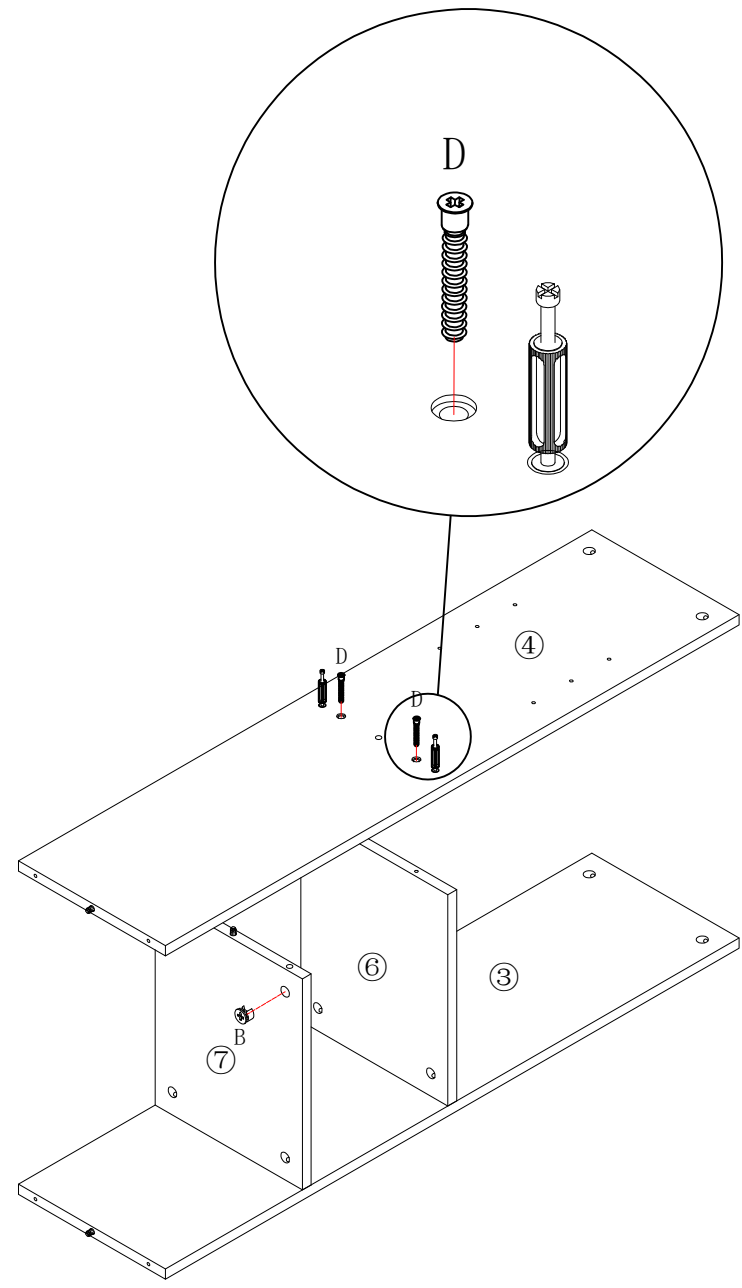

Make sure the arrow on the screw align to the hole on the side.



	B*6
	D*2

put B on board ⑥⑦

5

Make sure the arrow on the screw align to the hole on the side.

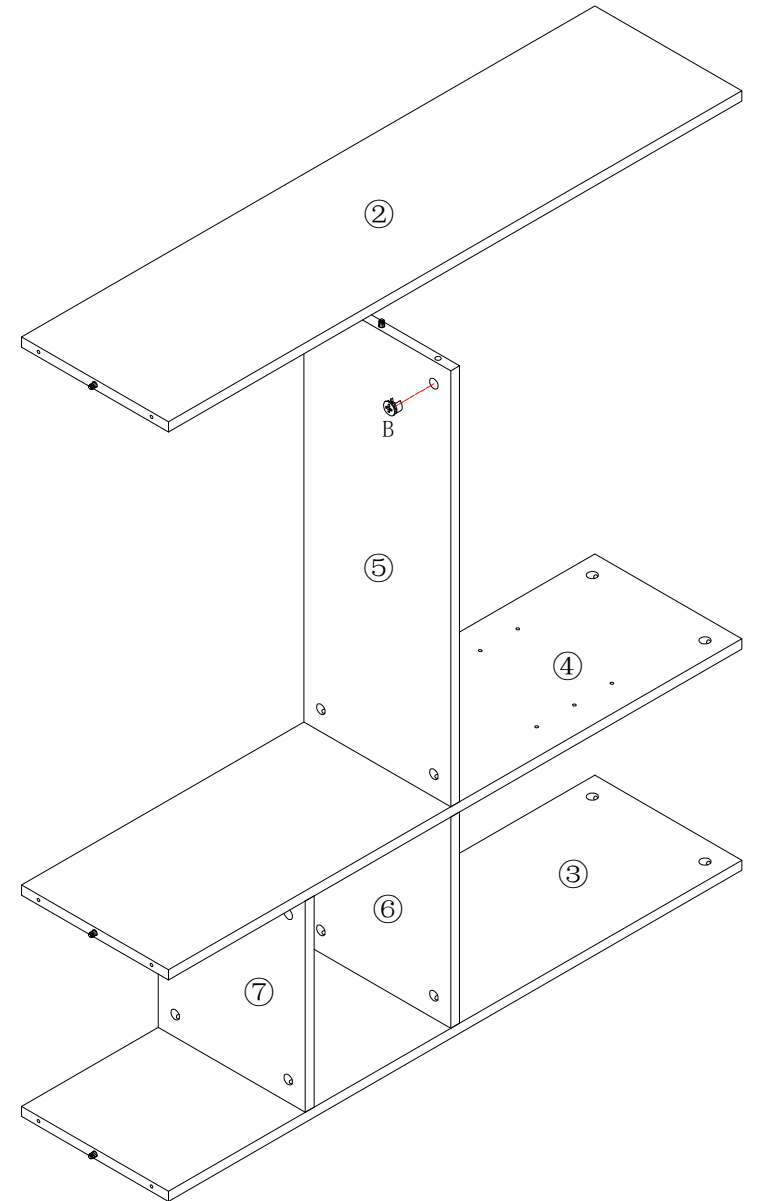
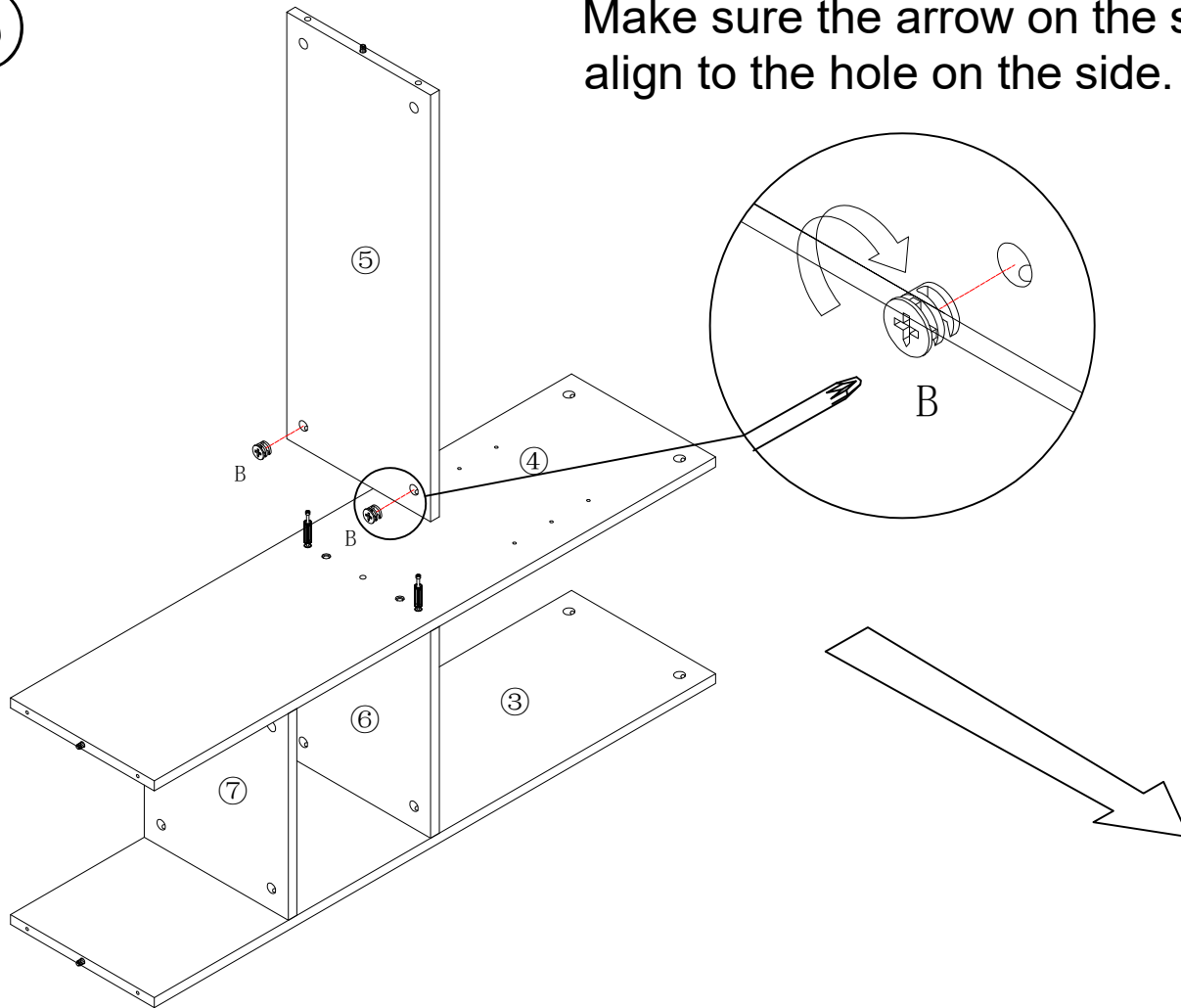

B*4 put B on board 5

6

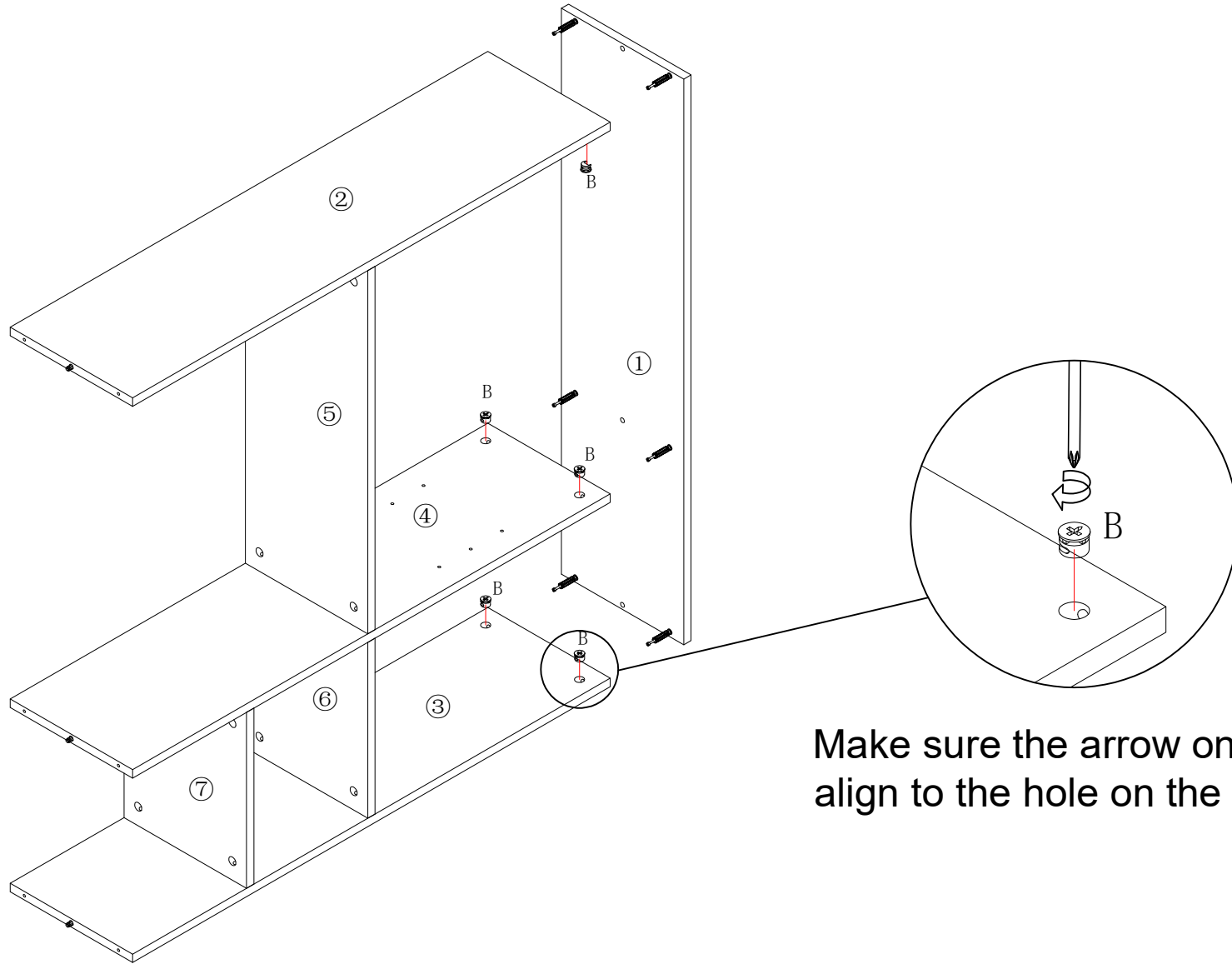

Make sure the arrow on the screw align to the hole on the side.



B*6 put B on board ②③④

7

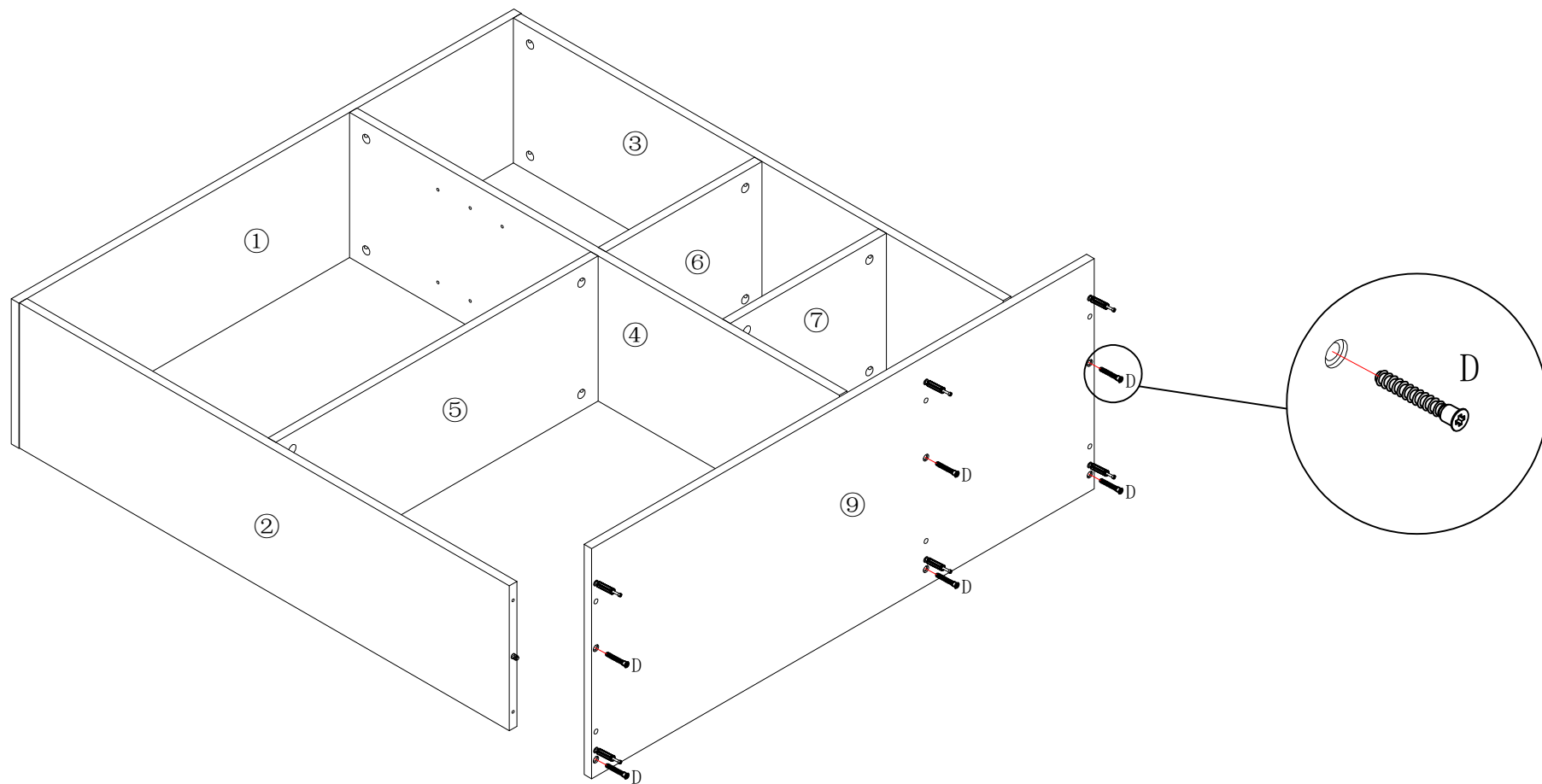

D*6

8

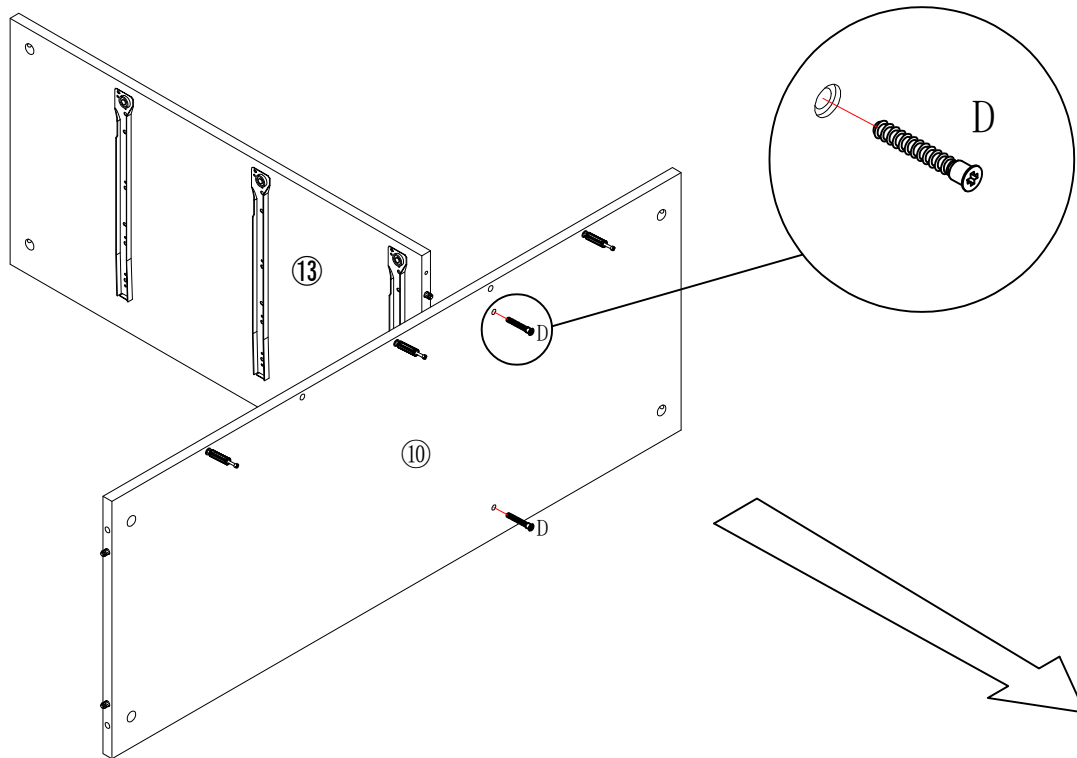

Make sure the arrow on the screw align to the hole on the side.

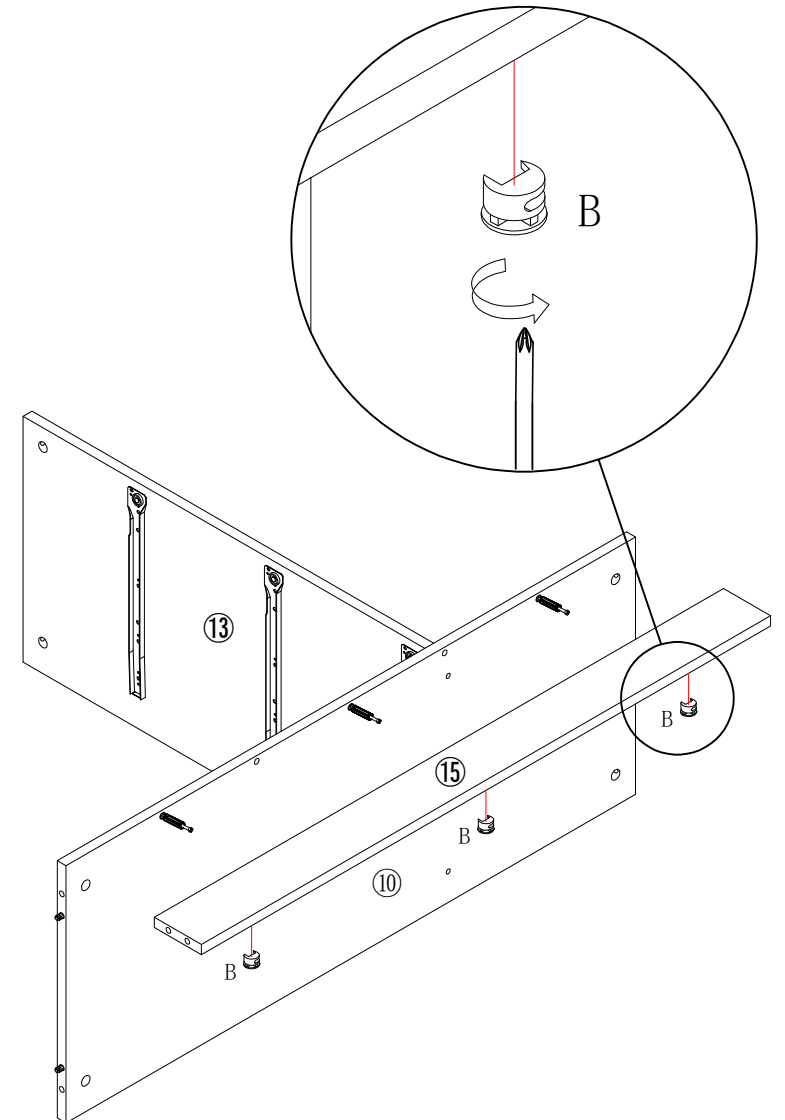

B*3

put B on board 15



D*2

9

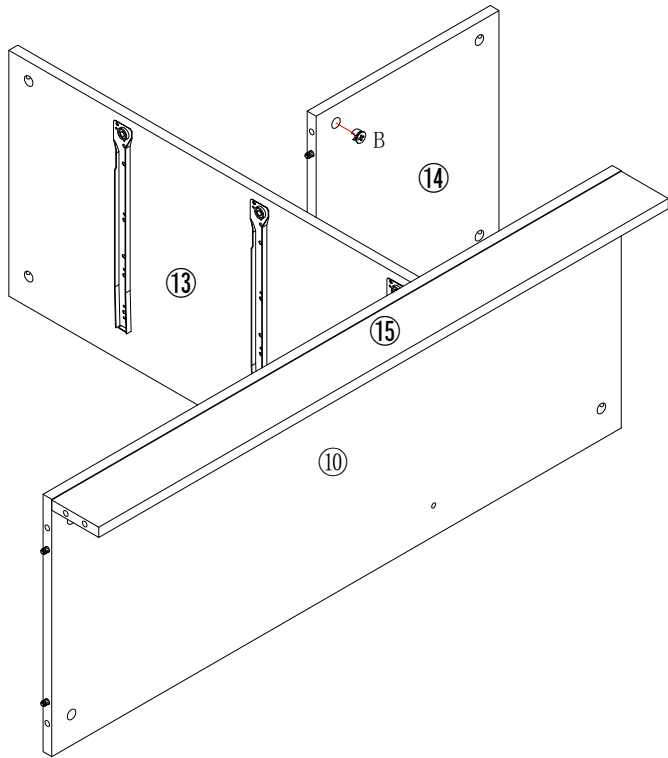

Make sure the arrow on the screw align to the hole on the side.

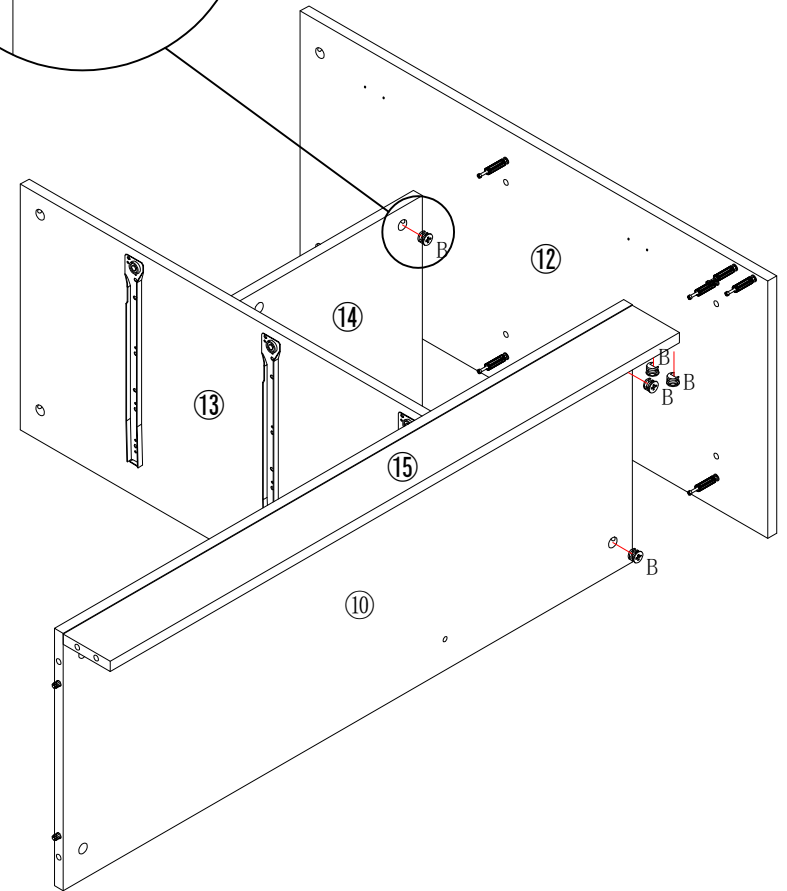
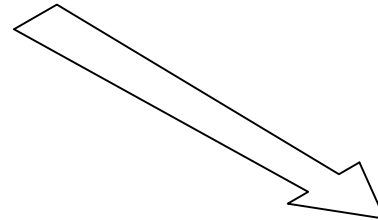
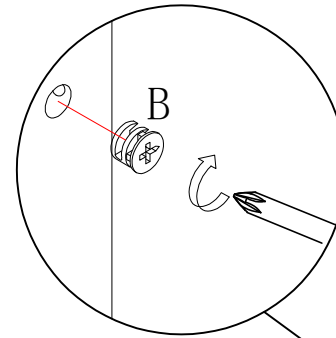



B*8 put B on board 10 14 15

10

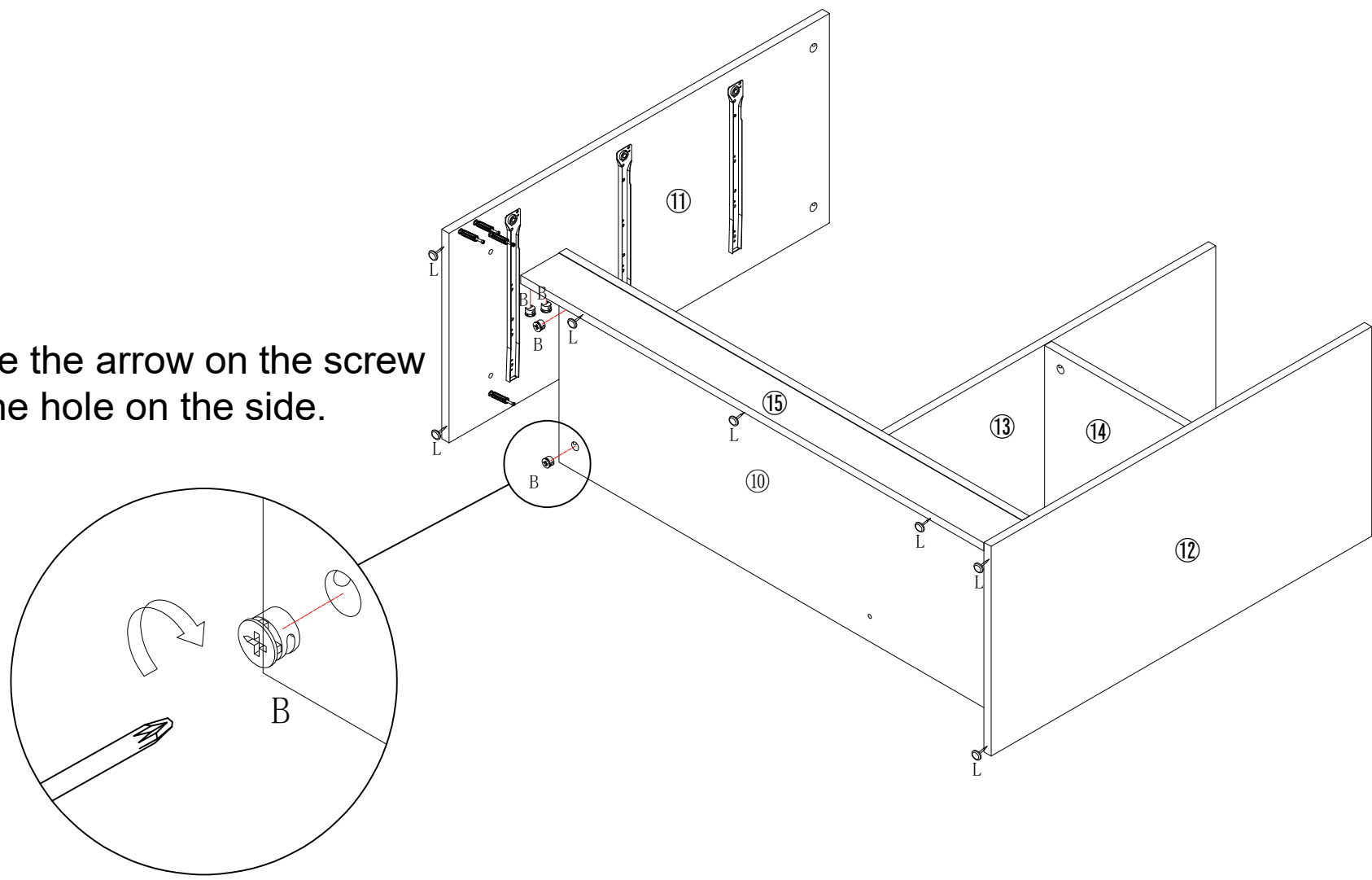
Make sure the arrow on the screw align to the hole on the side.



	B*4
	L*7

put B on board 10 15

11

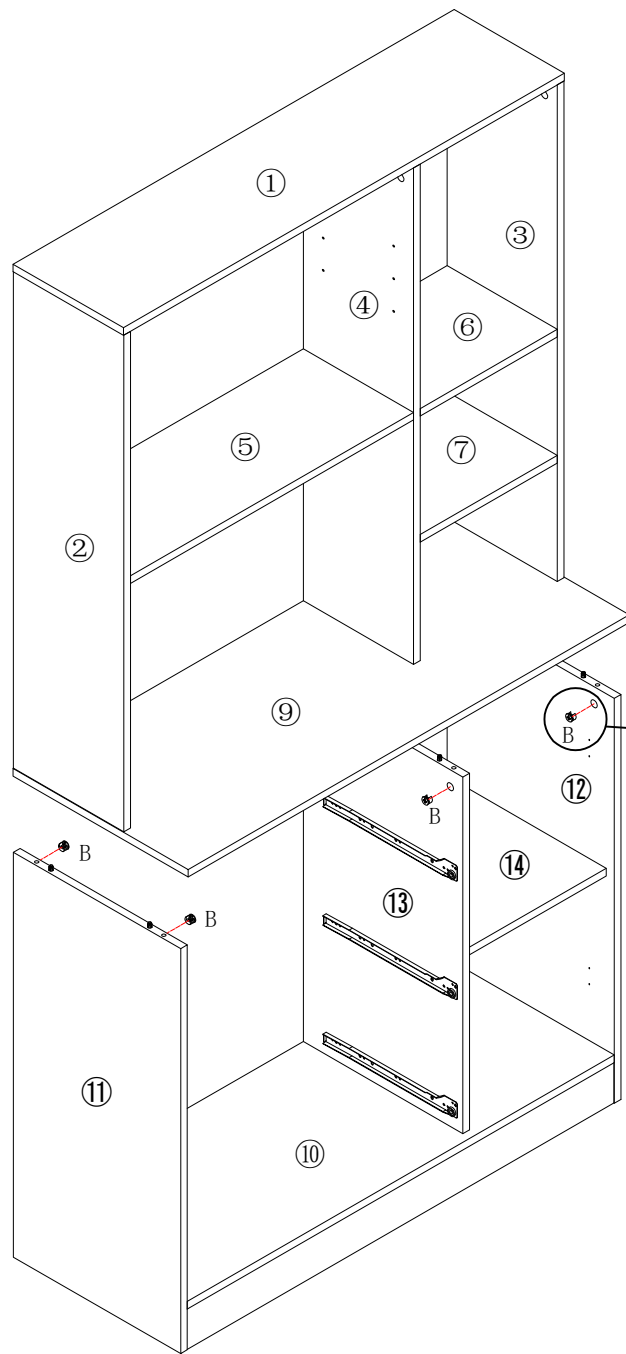

Make sure the arrow on the screw align to the hole on the side.

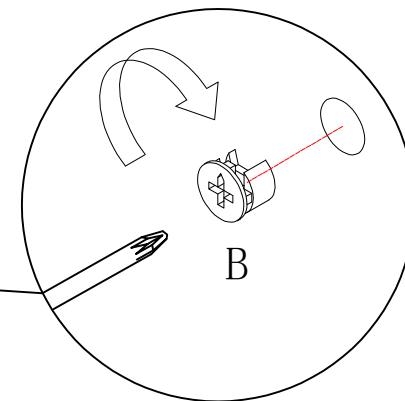

B*6

put B on board 11 12 13

12

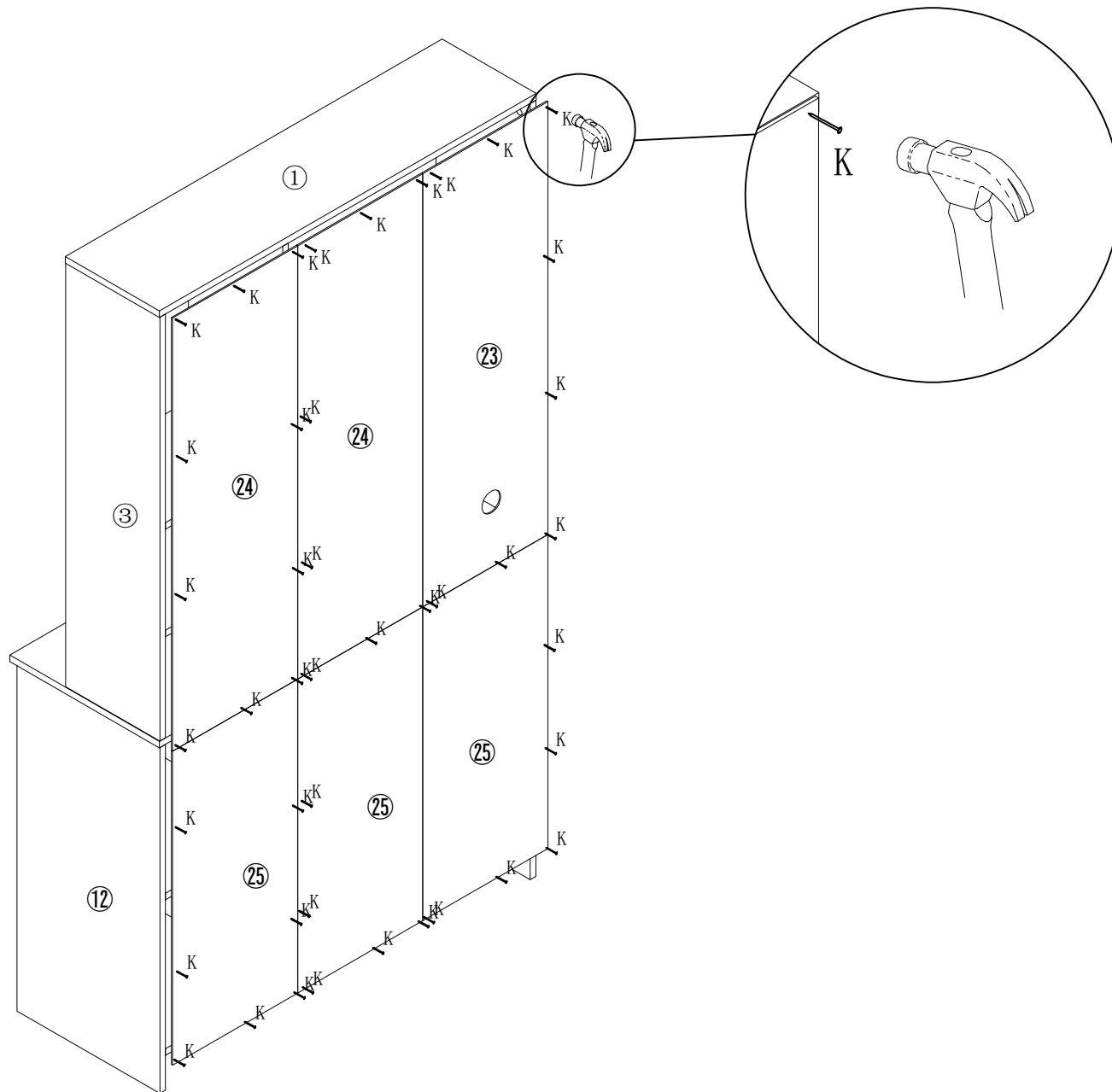

K*52

13

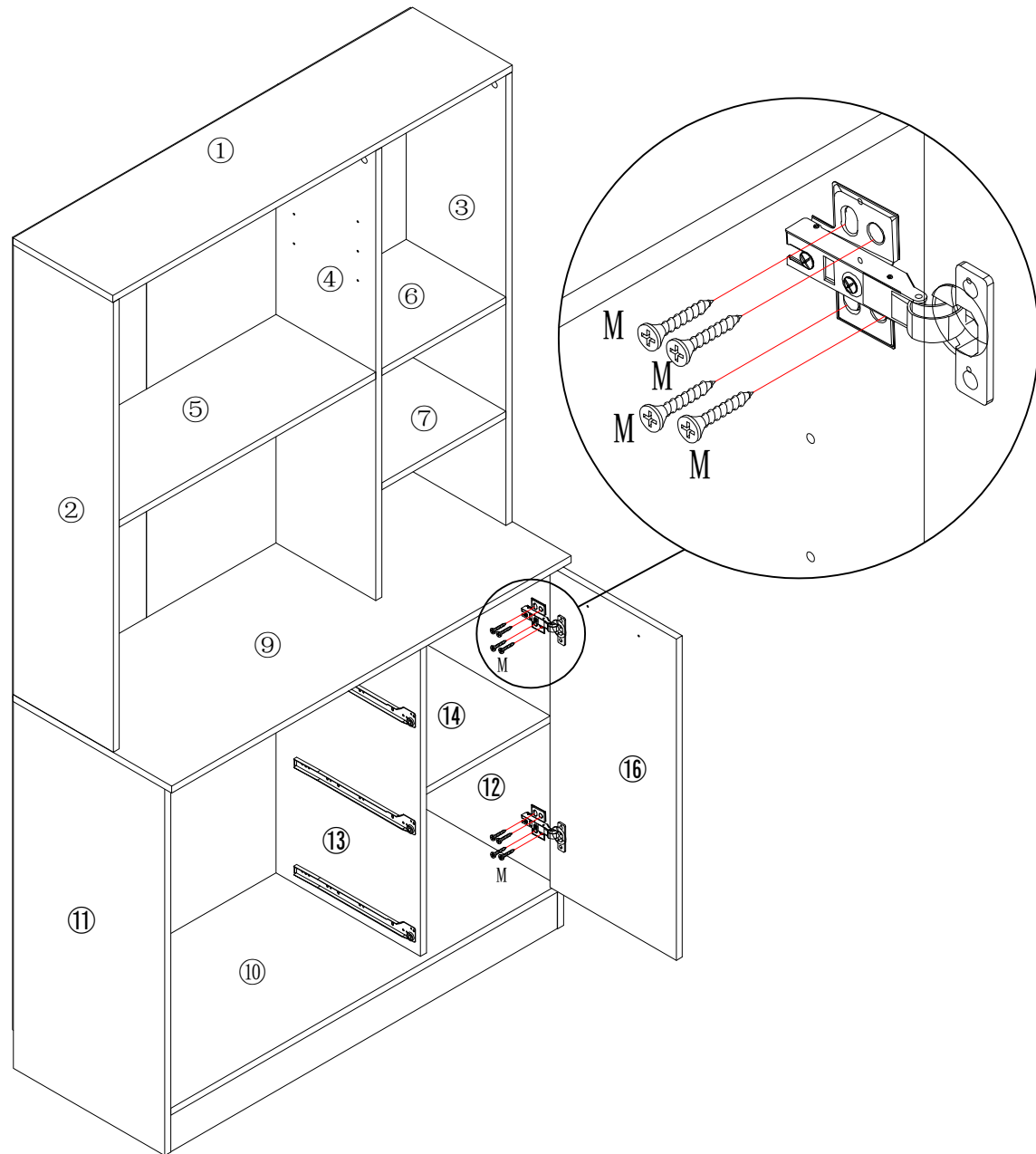
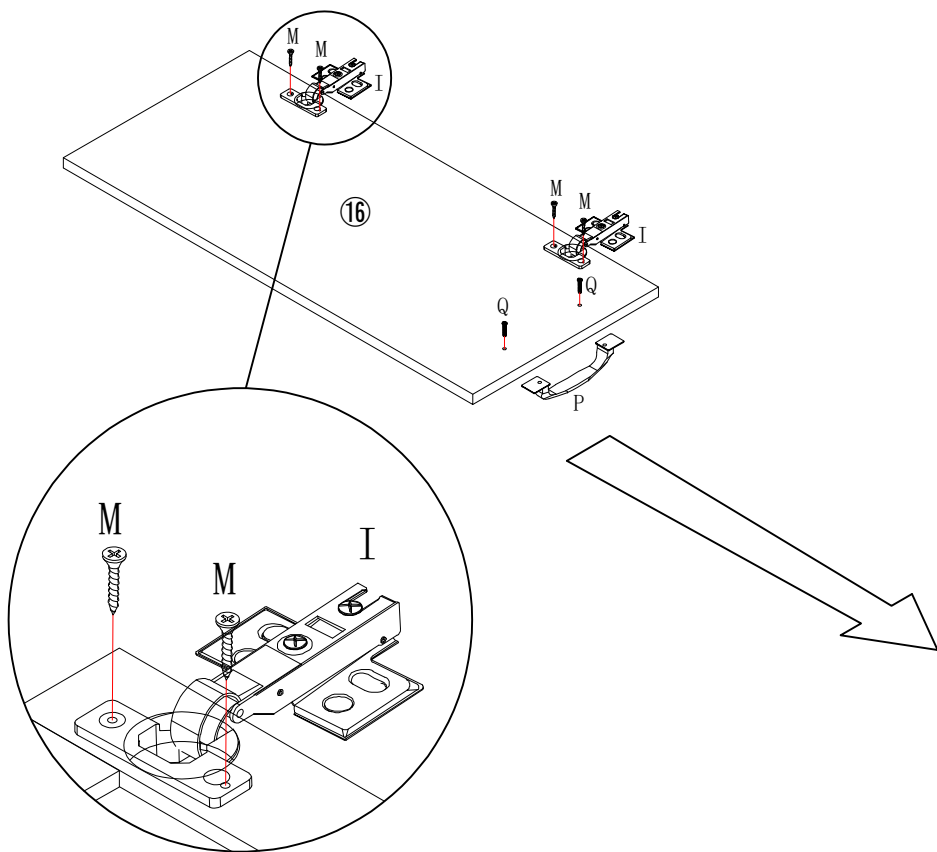

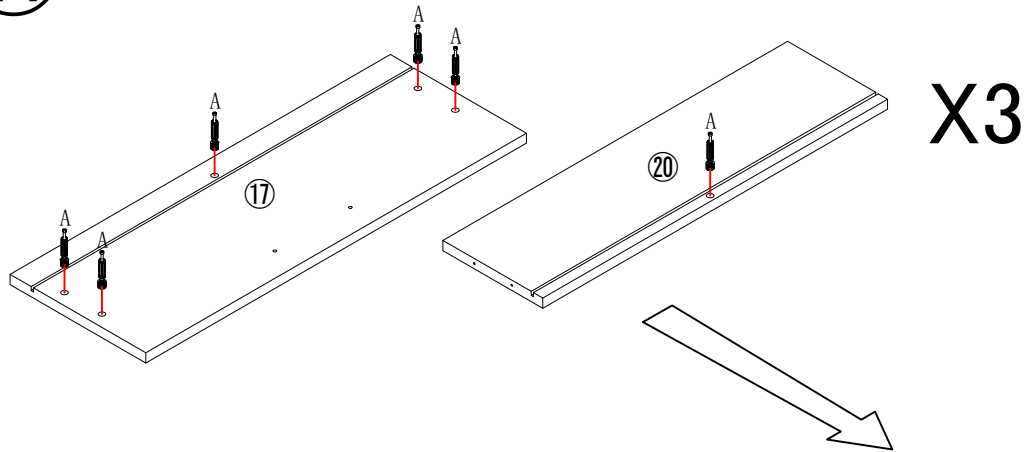

	I*2
	M*12
	P*1
	Q*2

14

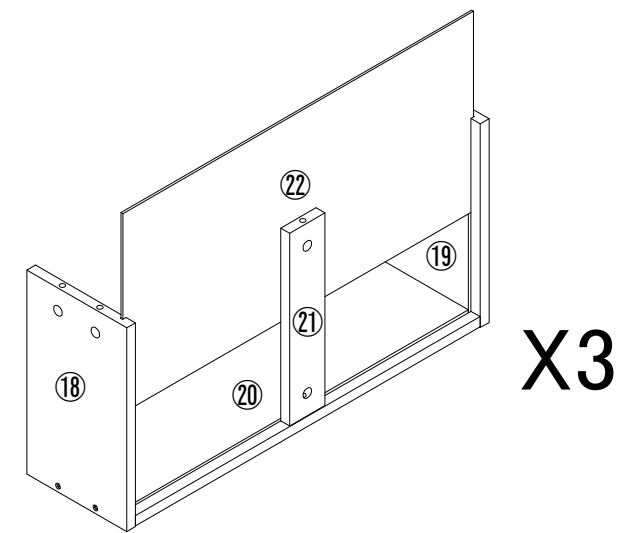
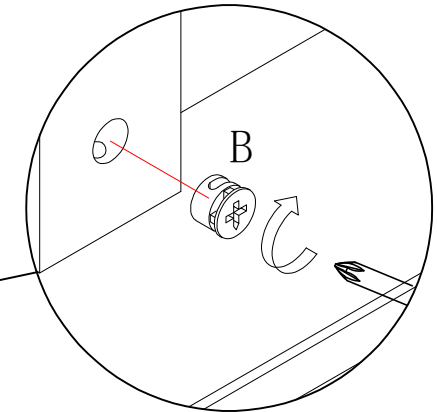
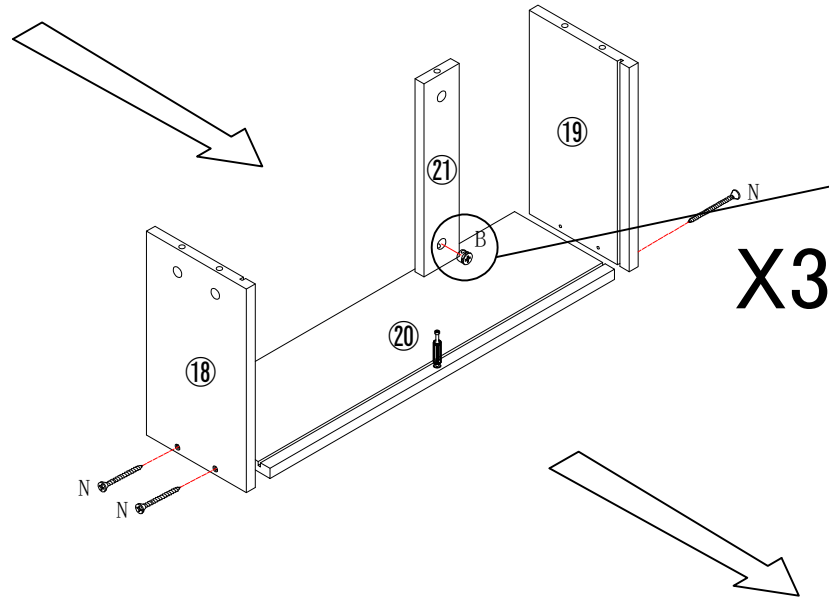

Make sure the arrow on the screw align to the hole on the side.

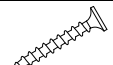

	A*18	put A on board 17 20
	B*3	put B on board 21
	N*12	

15

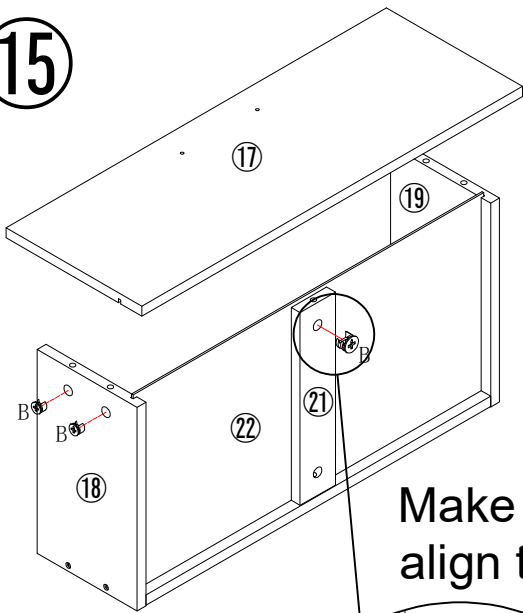

X3

Make sure the arrow on the screw align to the hole on the side.

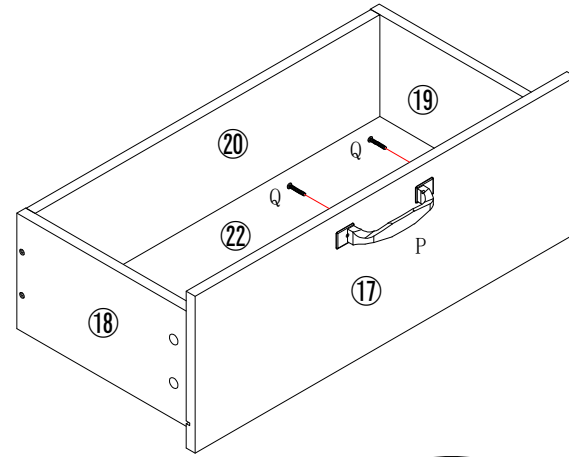
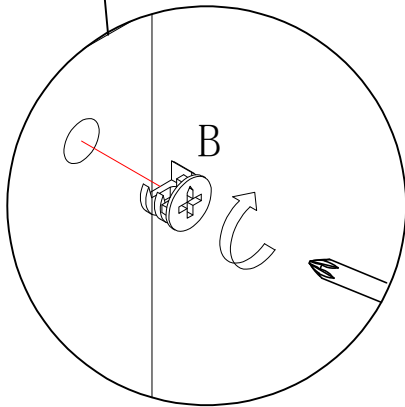



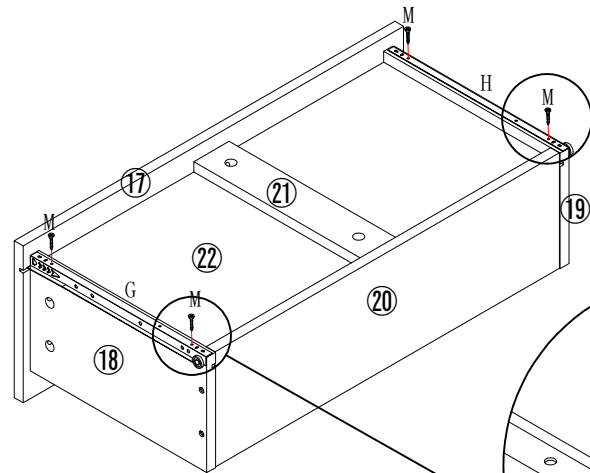
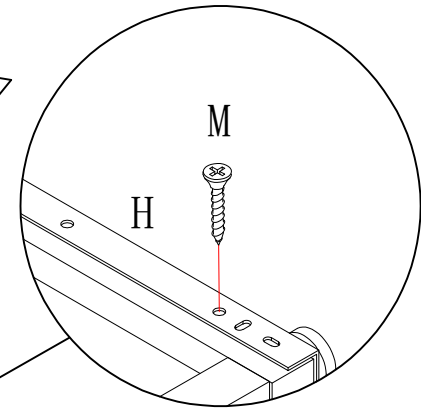
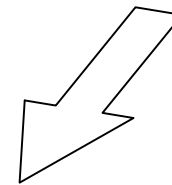

X3

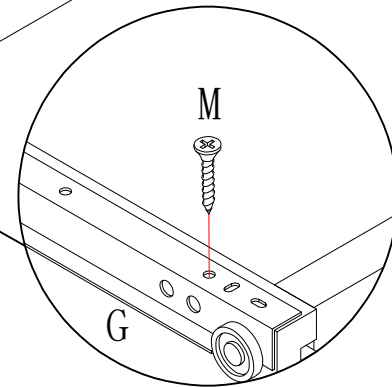

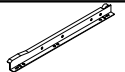
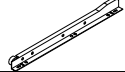
X3



	B*15
	G*3
	H*3
	M*12
	P*3
	Q*6

put B on board 18 19 21

16

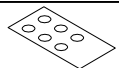
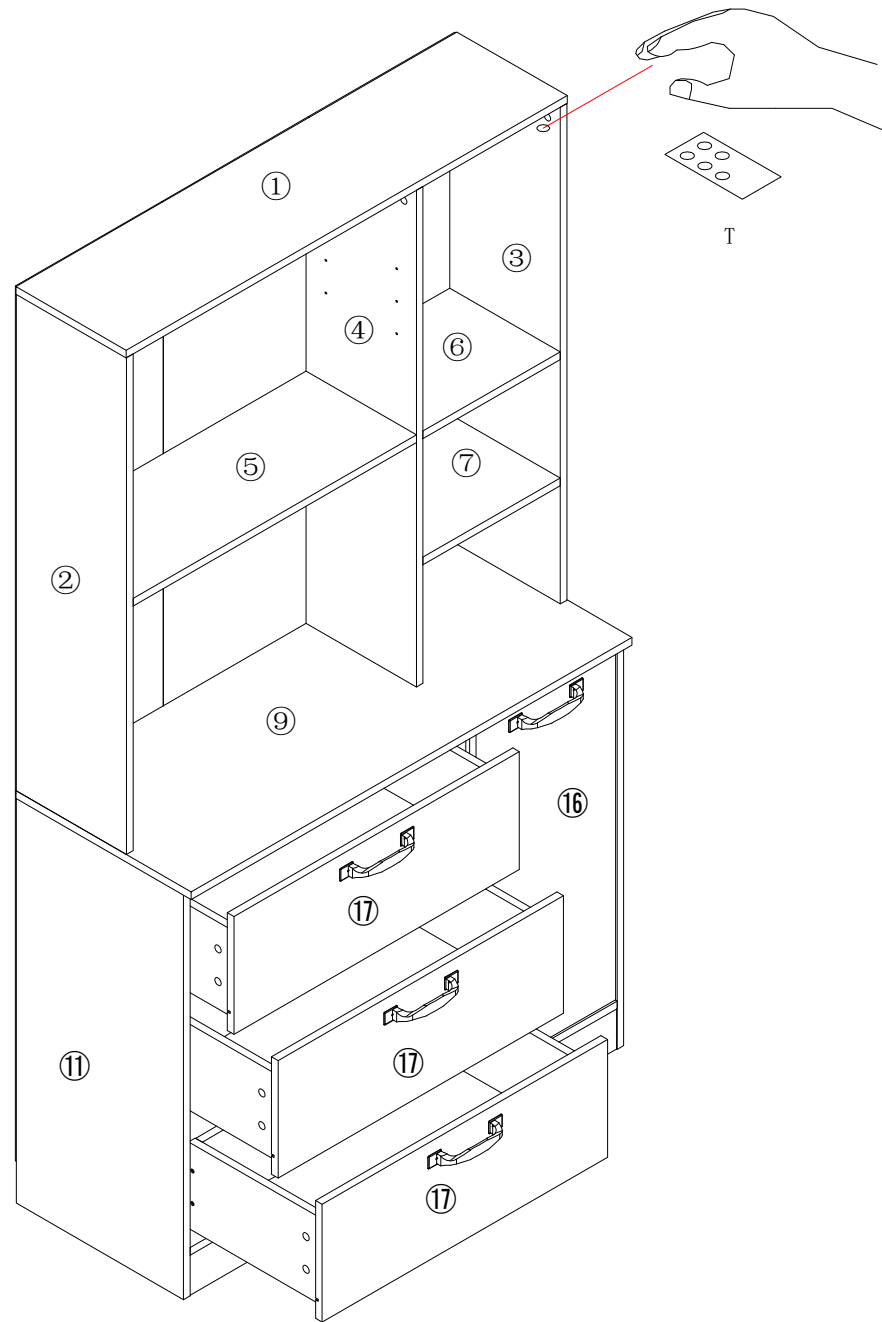

T*6

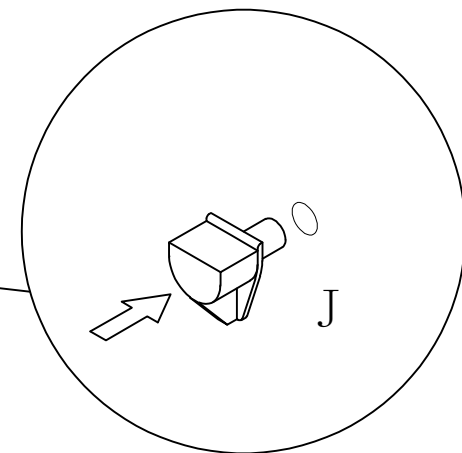
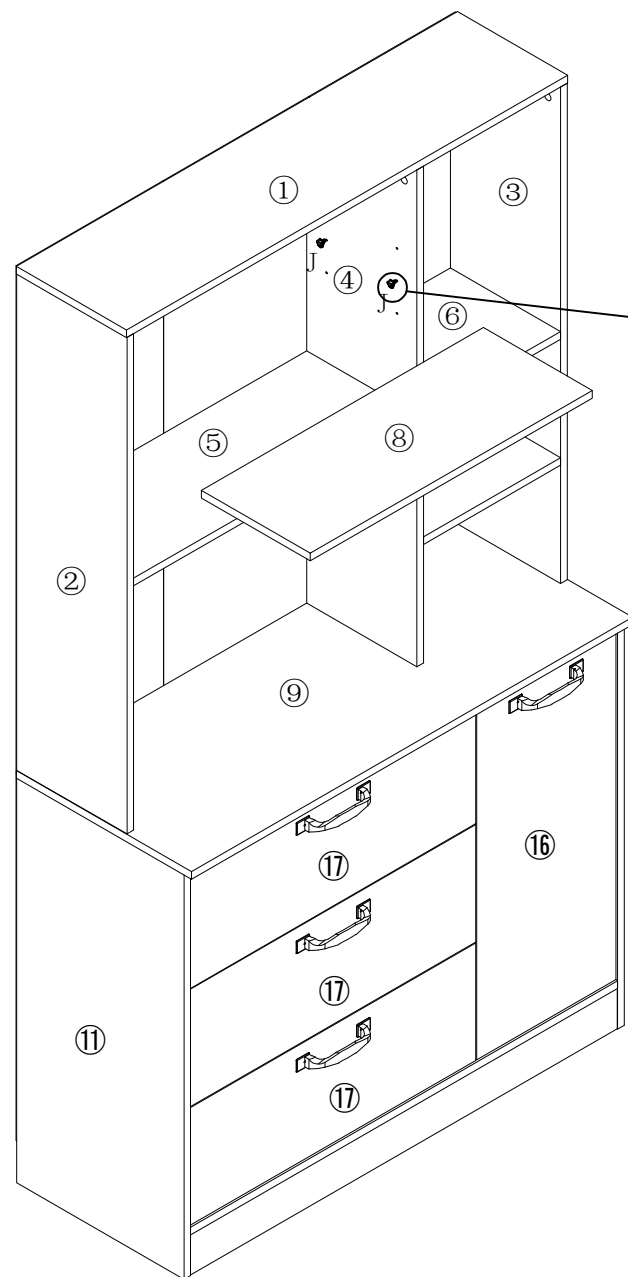

17

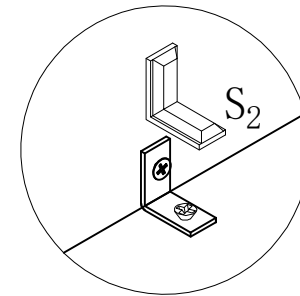
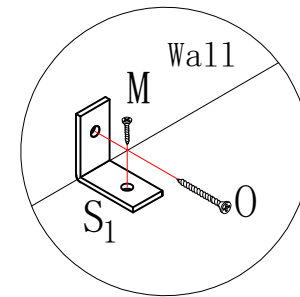
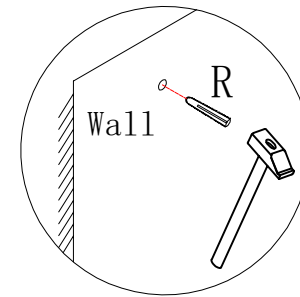
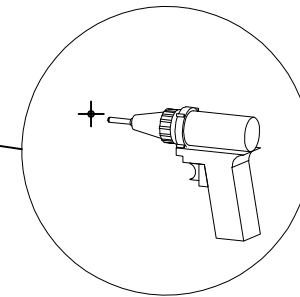
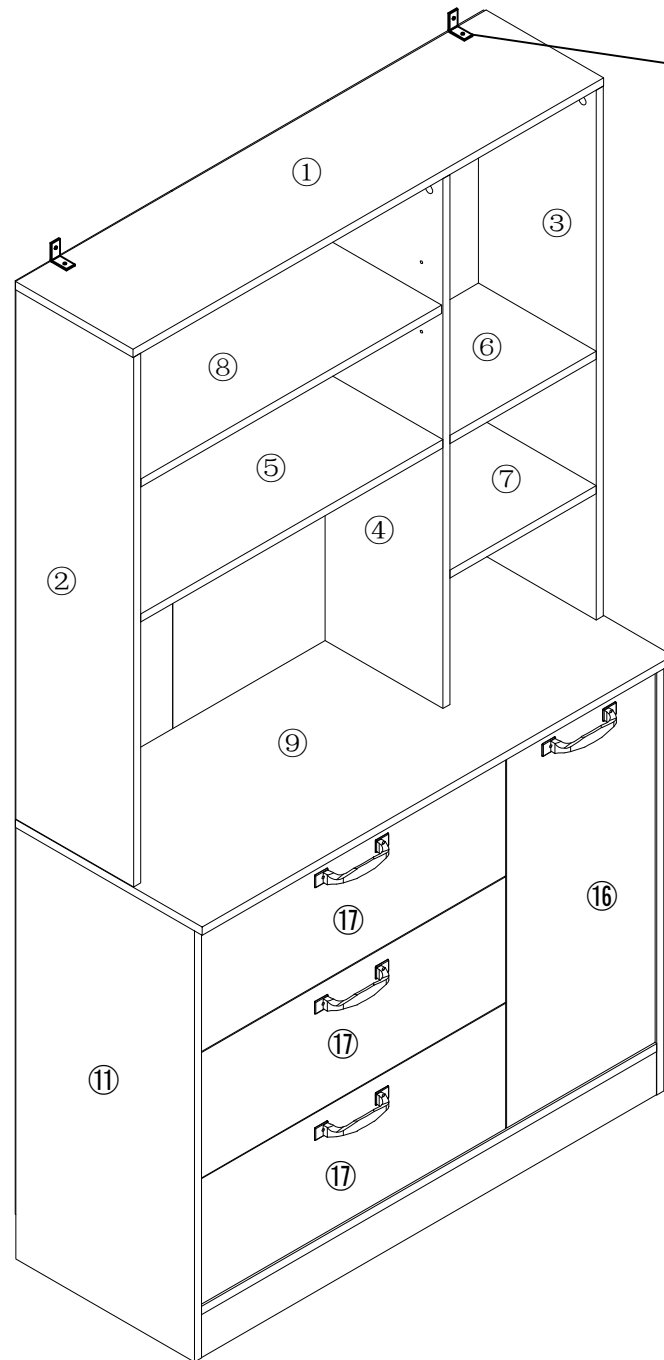

J*4

18

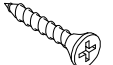
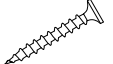

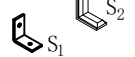
	M*2
	O*2
	R*2
	S*2

19

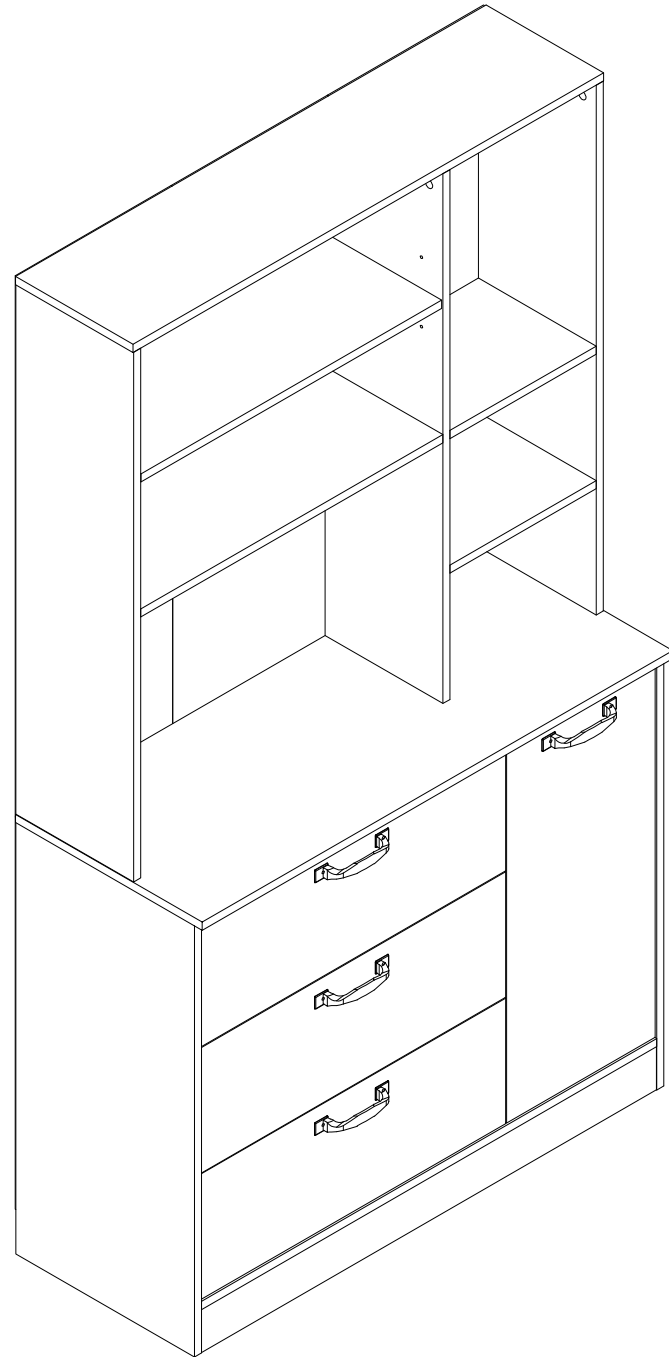

---END---