

ASSEMBLY INSTRUCTIONS

EXPANDABLE TABLE

ASSEMBLY
REQUIREMENTS

2-Person
Assembly

60 Minutes
Assembly Time
(Approximate)

Tools Required
(Not Provided)



Thank you for purchasing our product!

Please refer and use this assembly instruction to assemble the product. Contact our customer service department in case there are any missing or damage parts or hardware. Replacement parts are normally shipped within 2 or 3 days.

We appreciate your business!

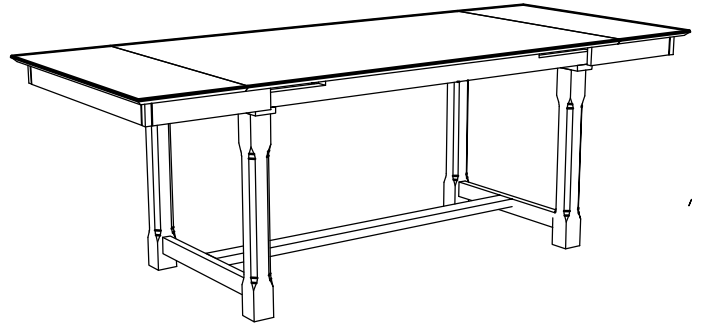

ASSEMBLY PREPARATION

1. Remove all packaging materials, staples and packing straps from the carton.
2. Refer to Parts List and Hardware List and ensure parts and hardware are correct before assembly. Contact customer service for missing parts.
3. Place all wooden parts on a clean, flat and soft surface (e.g. carpet or rug) to prevent scratch and damage to parts.

SAFETY PRECAUTION:

1. KEEP ALL HARDWARE PARTS OUT OF REACH OF CHILDREN.
2. DISPOSE PLASTIC PACKAGING MATERIAL IMMEDIATELY TO AVOID ANY RISK OF SUFFOCATION TO CHILDREN AND ANIMALS.

TIPS FOR ASSEMBLY:

1. Allow ample room for assembly and in close proximity to where product will be placed.
2. Assemble the product on a surface that does not scratch or damage the exterior gloss and finish of the furniture.
3. Identify all of the parts, hardware and quantities required for each step.
4. During assembly, do not over-tighten any fittings as this may cause damage.
5. DO NOT USE POWER TOOLS TO ASSEMBLE THIS PRODUCT.
6. Always place the product on a flat, level surface.
7. Do not sit or stand on the partially assembled product; only use the product for which it is intended.







CARE AND MAINTENANCE







- Use a slightly damp cloth to clean the product. Do not use bleach or abrasive cleaning material.
- Check all the fittings periodically and re-tighten as necessary. Do not use the product if any of the parts is damaged or broken.
- Never allow any kind of liquid to remain on your furniture. Absorption can cause wood to warp or delaminate.
- Do not place hot items (e.g. hot drinks) directly onto the wood surface.
- Do not drag and/or pull the furniture.

This product is for indoor and household use only - not for commercial use.

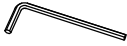
ASSEMBLY INSTRUCTIONS

EXPANDABLE TABLE

Part List		
No	Part Name	Qty
P1	Table Top & Apron 	1 pc
P2	Leg Rail (Top) 	1 pc
P3	Table Leg 	4 pcs
P4	Leg Rail (Bottom) 	1 pc
P5	Leg Support (top) 	2 pcs
P6	Leg Support (Bottom) 	2 pcs

Hardware List			
No	Hardware Name	Qty	Extra
H1	Allen Key M4x65 	1 pc	
H2	Allen Key M5x65 	1 pc	
H3	JCBB Screw M8 x 50mm 	22 pcs	2 pcs
H4	Spring Washer 5/16 	22 pcs	2 pcs
H5	JCBB Screw M6 x 30mm 	4 pcs	1 pc
H6	Spring Washer M6x13mm 	4 pcs	1 pc
H7	Wood Dowel M10x30mm 	12 pcs	2 pcs
H8	Leg Stud 	4 pcs	1 pc

" EXTRA HARDWARE FOR SPARE "

STEP 1

- Set Table Legs (P3) with the bottom base facing up as shown and insert Wood Dowel (H7) into the lower hole
- Attach Bottom Leg Support (P6) to (P3) via Wood Dowel
- Align the screw holes on each part and insert JCBC Screw (H3) fitted Spring Washer (H4). Use Allen Key (H2) to drive (H3) and tighten completely.

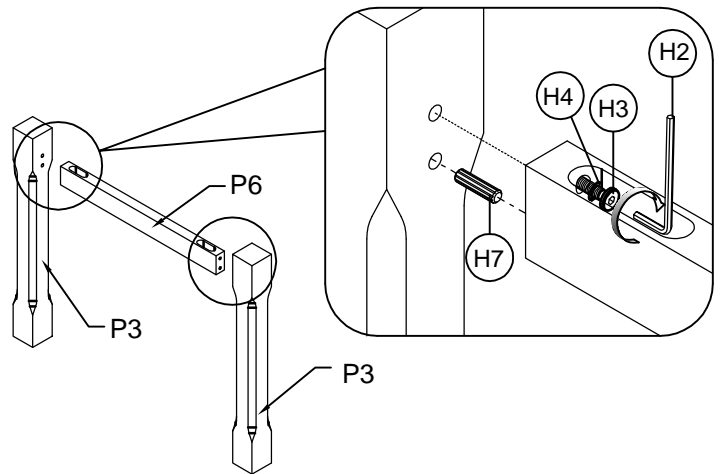

STEP 2

- Turn the Table Leg assemblies from STEP 1 right-side up and insert Wood Dowel (H7) into the middle hole as shown.
- Attach Top Leg Support (P5) to Table Leg (P3) via wood dowel.
- Align the screw holes on each part and insert JCBC Screw (H3) fitted Spring Washer (H4). Use Allen Key (H2) to drive (H3). Do not tighten the screws completely until both screws are in place.

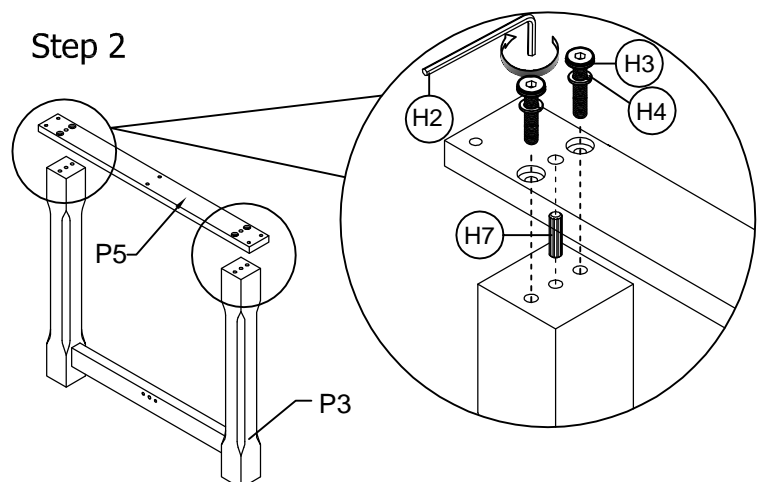

ASSEMBLY INSTRUCTIONS

EXPANDABLE TABLE

STEP 3

- Turn the leg assemblies from STEP 2 bottom-side up and insert Wood Dowel (H7) into the 2 outer holes on Bottom Leg Support (P6) as shown.
- Attach Bottom Leg Rail (P4) to Bottom Leg Support (P6) via wood dowel
- Insert JCBC Screw (H3) fitted Spring Washer (H4) into the designated hole on (P4). Use Allen Key (H2) to drive (H3) to fasten (P4) to (P6) and tighten completely.

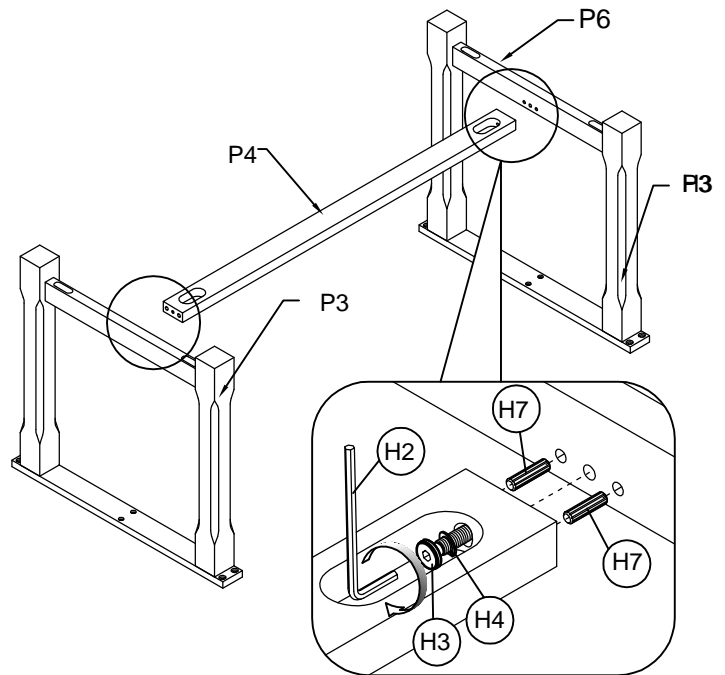

STEP 4

- Turn the assembly from STEP 3 right-side up as shown.
- Place Top Leg Rail (P2) to align the screw holes on (P2) to Top Leg Support (P5).
- Align the screw holes on each part and insert JCBC Screw (H5), fitted with Spring Washer (H6), from the bottom through (P5) to fasten (P2) to (P5). Use Allen Key (H1) to drive (H5). Do not tighten (H5) completely until both screws are in place.

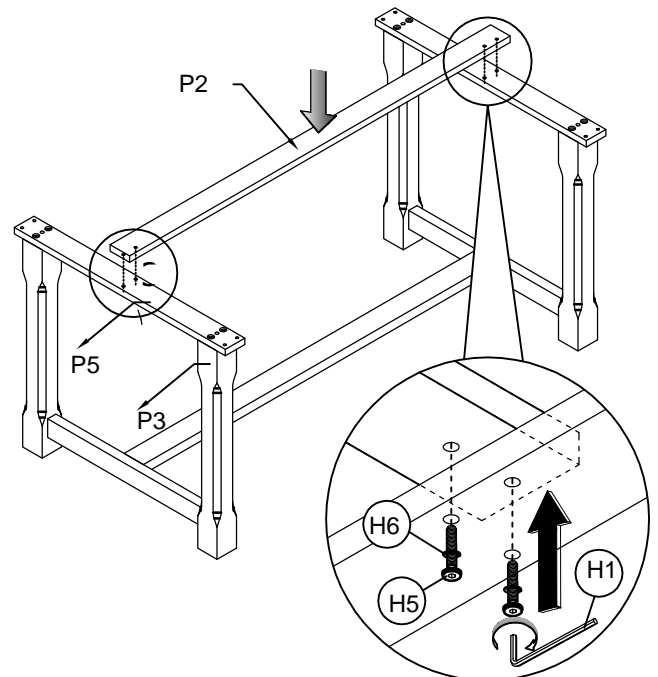

ASSEMBLY INSTRUCTIONS

EXPANDABLE TABLE

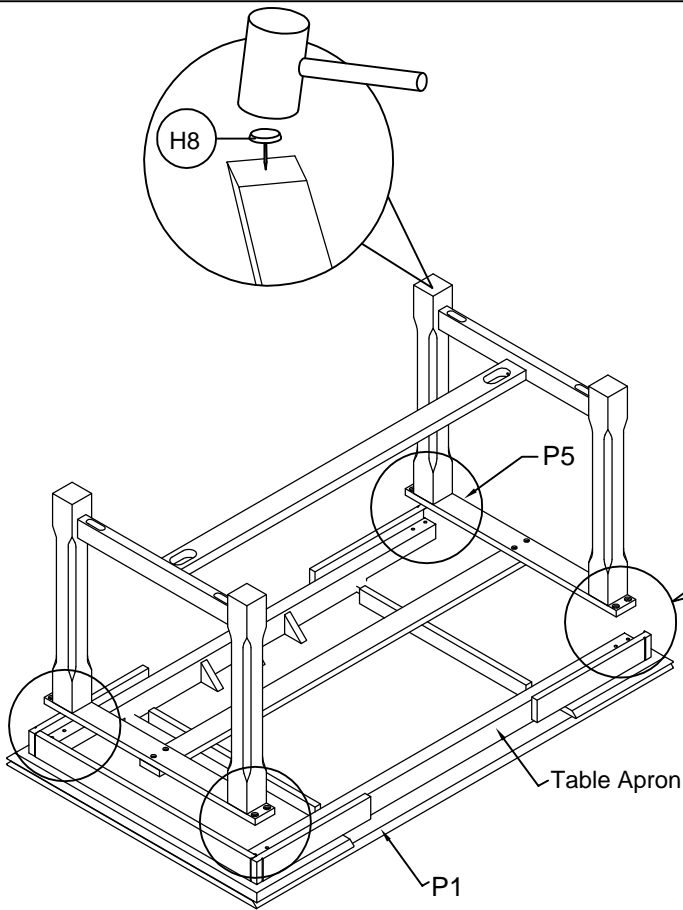

Drawing 5A

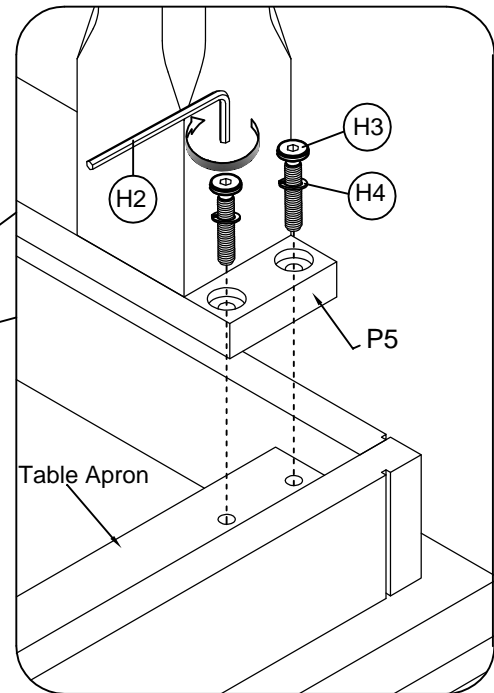

Drawing 5B

STEP 5

- With the assistance of another person, lay Table Top (P1) bottom-side up on a material that does not scratch or damage the part and position the assembly from STEP 4 upside-down as shown in Drawing 5A.
- Align the screw holes near the edge of Top Leg Support (P5) to the screw holes on the Table Apron as shown in Drawing 5B.
- Use JCBC Screw (H3) fitted with Spring Washer (H4) to fasten (P5) to Table Apron. Do not tighten (H3) completely until all 4 screws are in place on (P5). Do not over-tighten the screws.
- Use a mallet or hammer to gently nail Leg Stud (H8) into each leg as shown.
- With assistance, turn the table right-side up.

The assembly of the table is complete.

ASSEMBLY INSTRUCTIONS

EXPANDABLE TABLE

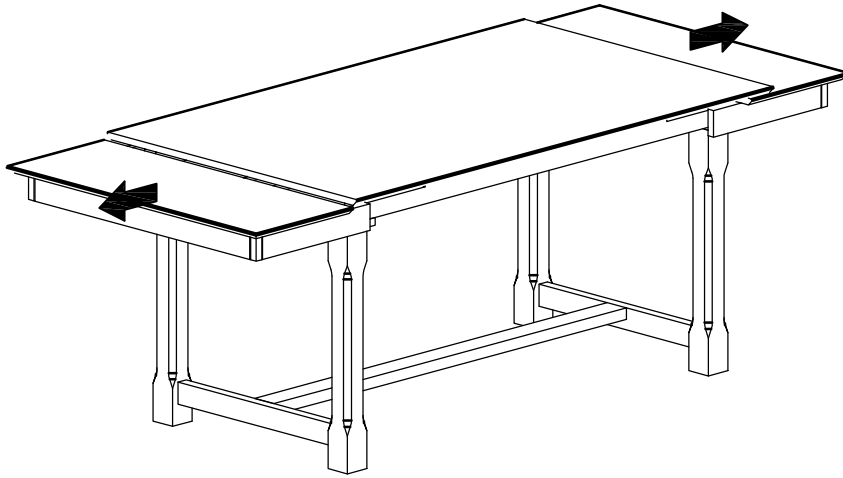

To expand the table, please pull out the leaf underneath table top and hand push the leaf upward to level the leaf with table top. Once in level, please push the leaf into table top and fix the position as picture.

