

I870101135A1/A2/A3

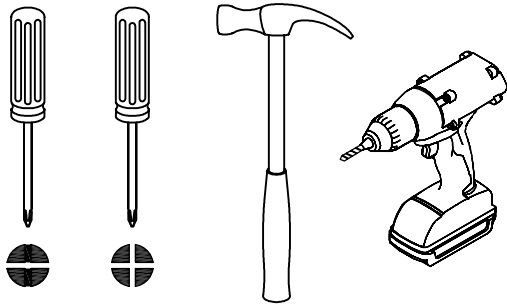

Tools required
(not included)

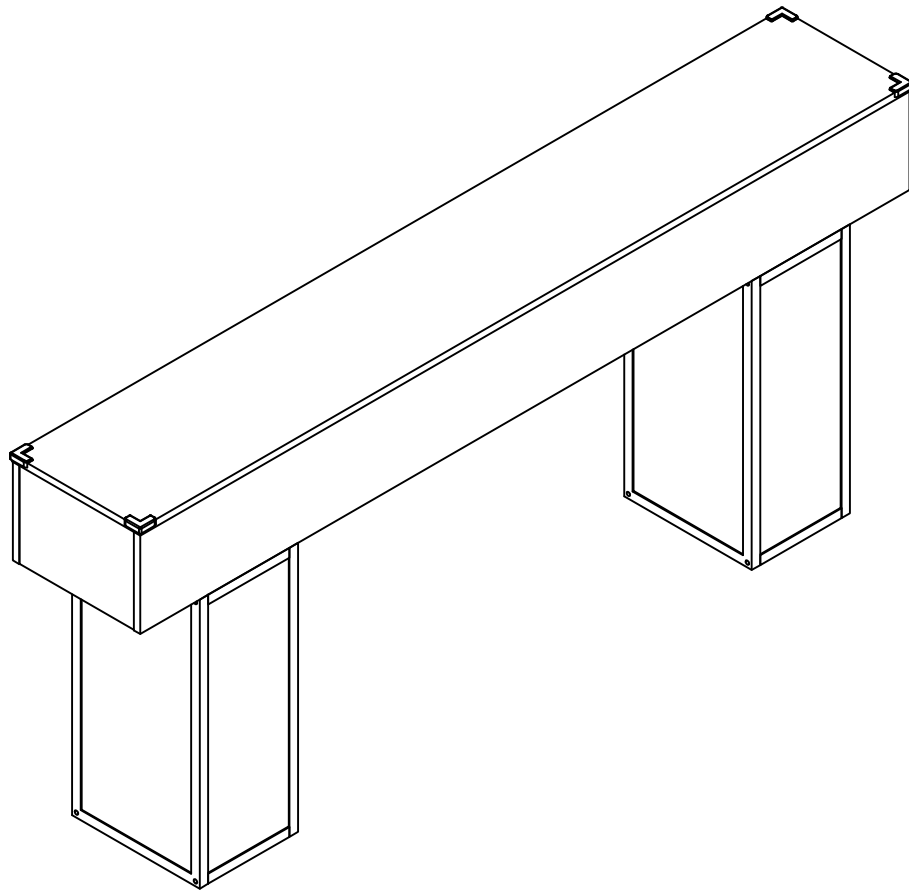
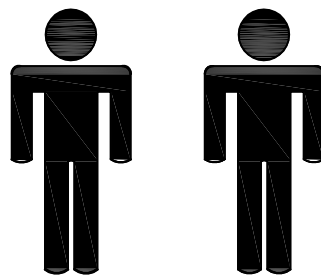

2 people for assembly



Safety and Care Advice

Important – Please read these instructions fully before starting assembly

- Check you have all the components and tools listed on the following pages.
- Remove all fittings from the plastic bags and separate them into their groups.
- Keep children and animals away from the work area, small parts could choke if swallowed.
- Make sure you have enough space to layout the parts before starting.

- During assembly do not stand or put weight on the product, this could cause damage.
- Assemble the item as close to its final position (in the same room) as possible.
- Assemble on a soft level surface to avoid damaging the unit or your floor.
- Parts of the assembly will be easier with 2 people.



- To reduce the likelihood of damaging your product please ensure that your power drill is set on a low torque setting.

Care and maintenance

- Only clean using a damp cloth and mild detergent, do not use bleach or abrasive cleaners.
- From time to time check that there are no loose screws on this unit.
- This product should not be discarded with household waste. Take to your local authority waste disposal centre.

Handy Hints

- Assemble all parts and bolts loosely during assembly, only once the product is complete should you fully tighten the bolts
- Regularly check and ensure That all bolts and fittings are tightend properly.

WARNING

In order to help prevent overturning - please follow these instructions

To help prevent product toppling over please follow the below steps:-

Use the anti tip stap or wall fixing method provided (if applicable)
Do not allow children to climb or hang on the furniture
Do not open more than one drawer at a time
Do not place heavy items in the top drawers
Do not place heavy items on top of the furniture, unless the furniture has been designed for this purpose

Please note that only the anti tip strap is provided.
You will need to provide wall plugs and screws applicable for your wall type

Notes:

1. ASSEMBLY PREPARATION AND TIPS FOR ASSEMBLY

- 1). Remove all packaging materials, staples and packing straps from the carton.
- 2). Refer to Parts List and Hardware List, and ensure parts and hardware are correct before assembly. Contact customer service for missing parts.
- 3). Place all wooden parts on a clean, flat and soft surface (e.g. carpet or rug) to prevent scratch and damage to parts.
- 4). Allow ample room for assembly and assemble the product near where the product will be placed.
- 5). During assembly, do not over-tighten any fittings as this may cause damage.
- 6). Always place the product on a flat, level surface.

2. CARE AND MAINTENANCE

- 1). KEEP ALL HARDWARE PARTS OUT OF REACH OF CHILDREN.
- 2). Wipe clean with a soft, dry cloth; avoid the use of harsh chemicals or household cleaners as they may damage the exterior finish of the furniture.
- 3). Hardware may loosen over time. Periodically, check that all connections are tight; re-tighten as necessary.

3. TIPS TO PROTECT & CARE FOR YOUR FURNITURE

- 1). Avoid placing your furniture in direct sunlight, as sunlight causes fading.
- 2). Use a protective pad when writing on the furniture surface.
- 3). Use cutting boards and trivets for food preparation in order to avoid damaging the top for the unit.

WARNING



Children have died from furniture tipover. To reduce the risk of furniture tipover:

- ALWAYS install tipover restraint provided.
- NEVER put a TV on this product.
- NEVER allow children to stand, climb or hang on drawers, doors, or shelves.
- NEVER open more than one drawer at a time.
- Place heaviest items in the lowest drawers.



This is a permanent label.
Do not remove!

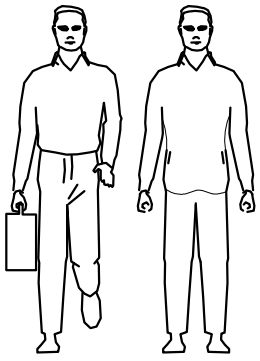

2-Person Assembly



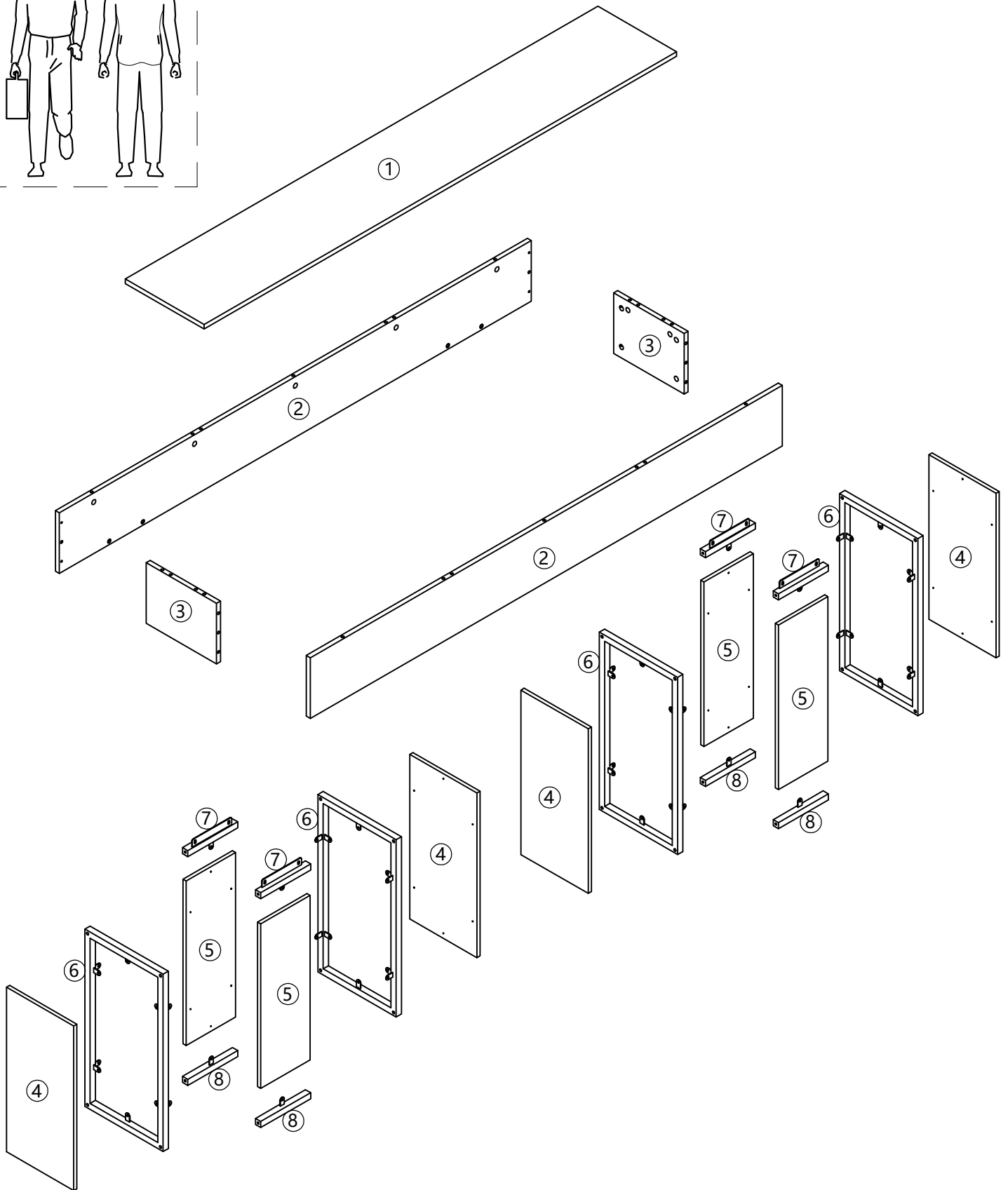



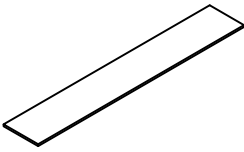
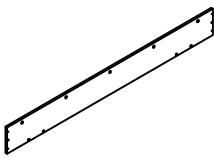
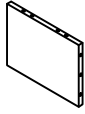
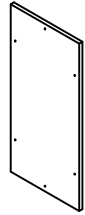
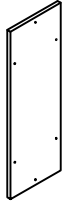
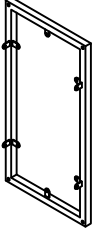

ASSEMBLY OVERVIEW

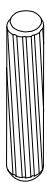

PART LIST

<p>① X1 PCS</p> 	<p>② X2 PCS</p> 	<p>③ X2 PCS</p> 	<p>④ X4 PCS</p> 	<p>⑤ X4 PCS</p> 
<p>⑥ X4 PCS</p> 	<p>⑦ X4 PCS</p> 	<p>⑧ X4 PCS</p> 		

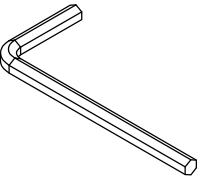
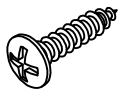
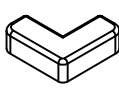
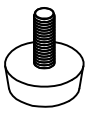
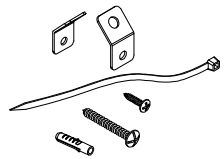
HARDWARE LIST

<p>A</p>  <p>Ø6*35mm</p> <p>22 PCS (Extra 2)</p>	<p>B</p>  <p>Ø15*10mm</p> <p>22PCS (Extra 2)</p>	<p>C</p>  <p>Ø8*30mm</p> <p>12PCS (Extra 2)</p>	<p>D</p>  <p>M6*12mm</p> <p>8 PCS (Extra 2)</p>	<p>E</p>  <p>M6*30mm</p> <p>16PCS (Extra 2)</p>
<p>F</p>  <p>S4</p> <p>1PCS</p>	<p>G</p>  <p>Ø4*12mm</p> <p>48 PCS (Extra 4)</p>	<p>H</p>  <p>4 PCS</p>	<p>I</p>  <p>8 PCS (Extra 1)</p>	<p>J</p>  <p>2 PCS</p>
<p>K</p>  <p>1 PCS</p>				

Instructions For Fastening CAM-BOLT and CAM-LOCK

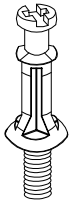

CAM-BOLT

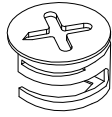

CAM-LOCK

Tools Required

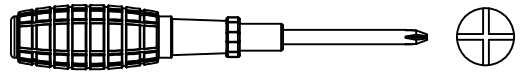

INSERTING AND TIGHTENING CAM-BOLT

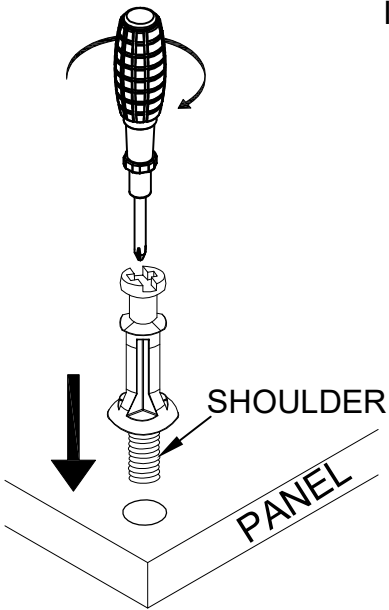

Place Cam-bolt on pre-drilled hole and screw in vertically

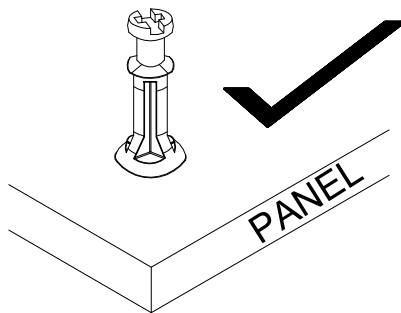

Shoulder is flushed (on the same level) with the panel.

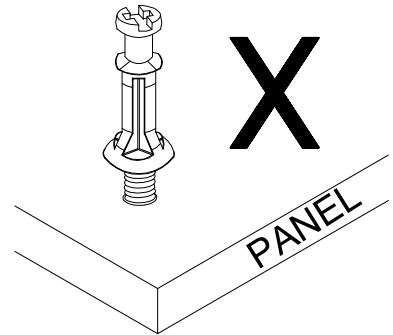

Shoulder is above the panel.

Place Cam-bolt on the designated pre-drilled holes on the panel. Use a Phillips Screwdriver to screw-in Cam-bolt vertically until shoulder is flushed (on the same level) with panel.

INSERTING CAM-LOCK

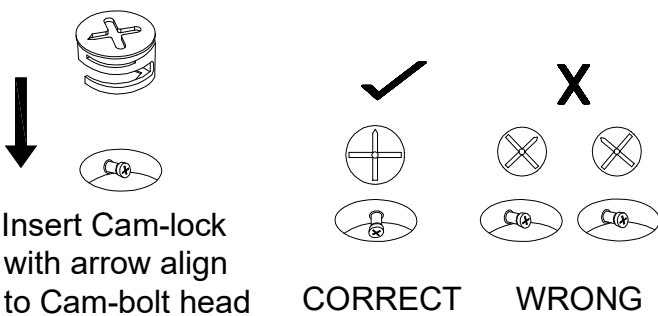

Insert Cam-lock with arrow align to Cam-bolt head

CORRECT

WRONG

TIGHTENING CAM-LOCK

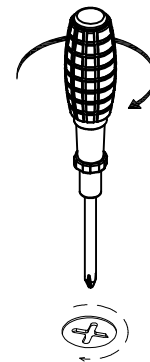

Align the arrow on the Cam-lock to the Cam-bolt head and insert the Cam-lock. Ensure Cam-lock is fully inserted.

Use a Flat-head Screwdriver to turn Camlock clockwise so it locks onto the head of the Cam-bolt. Turn until it is snug (about 3/4ths of a turn) -- over-tightening could damage Cam-lock or/and Cam-bolt.

Step 1.

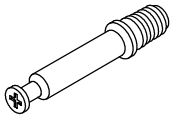

A x8

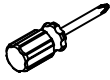

K x1

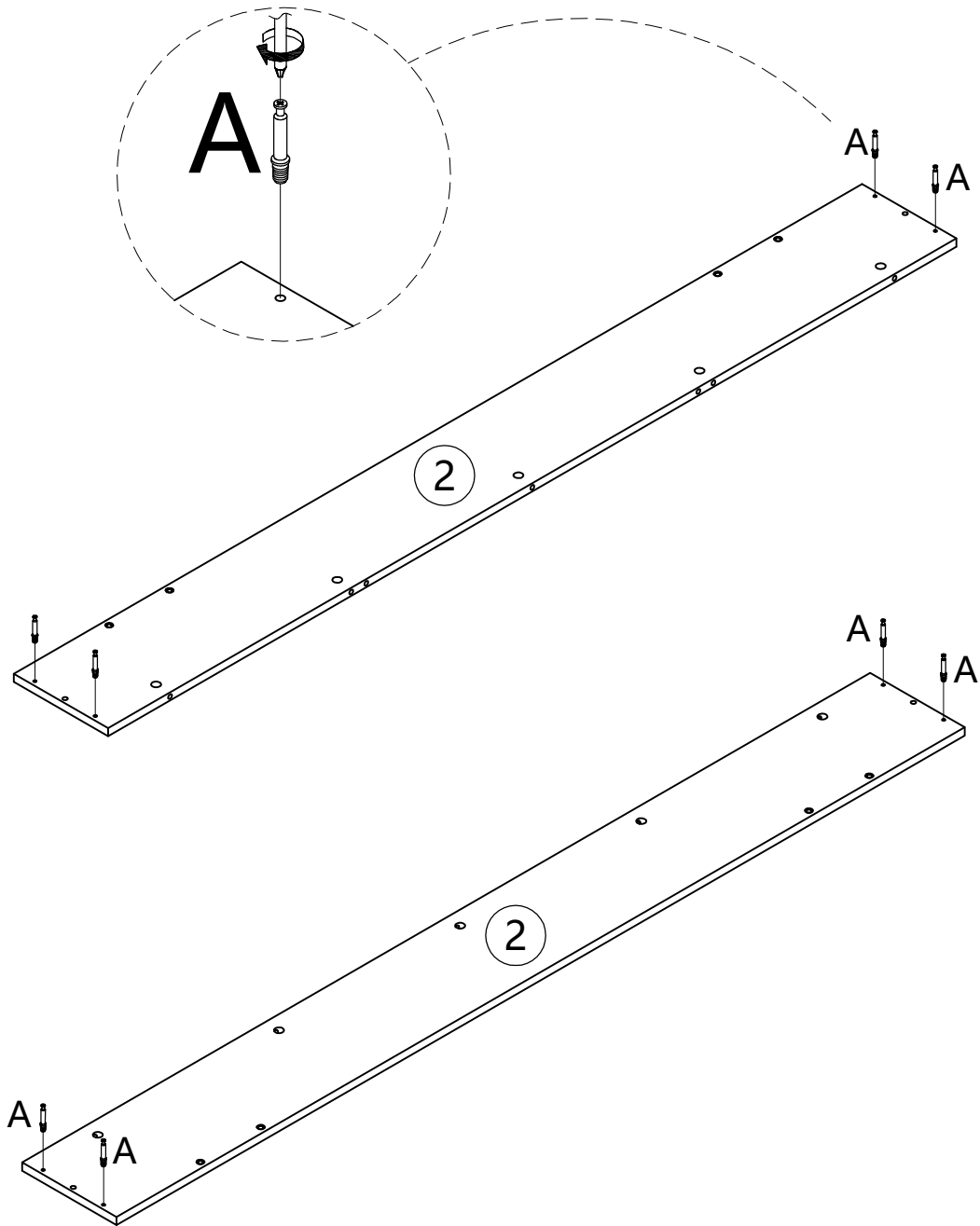

Step 2.



B x 8

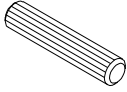

C x 4

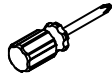

K x 1

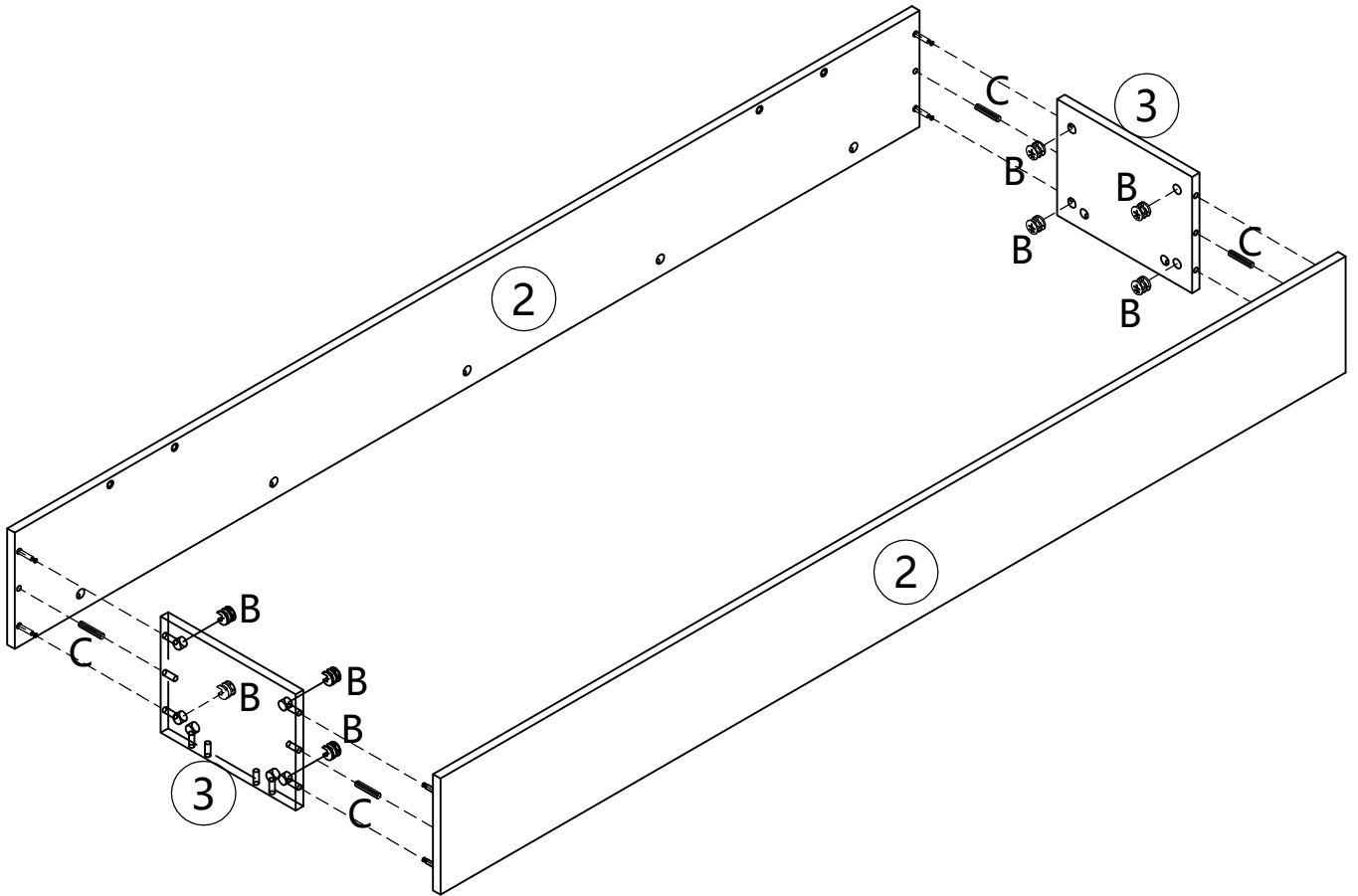

Step 3.

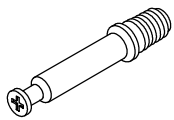

A x14



B x 14

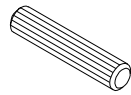

C x 8

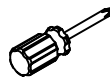

K x1

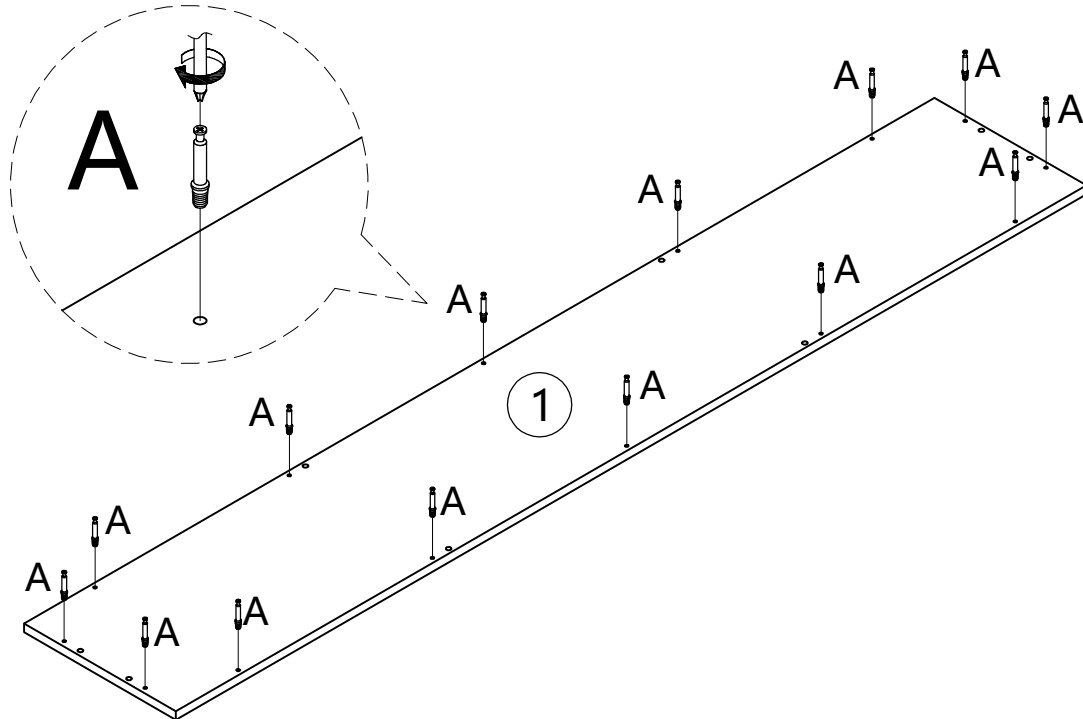

2-Person
Assembly

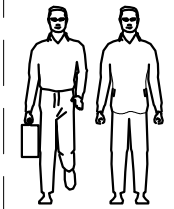

Please note that
this step requires
two - person
cooperation for
installation.

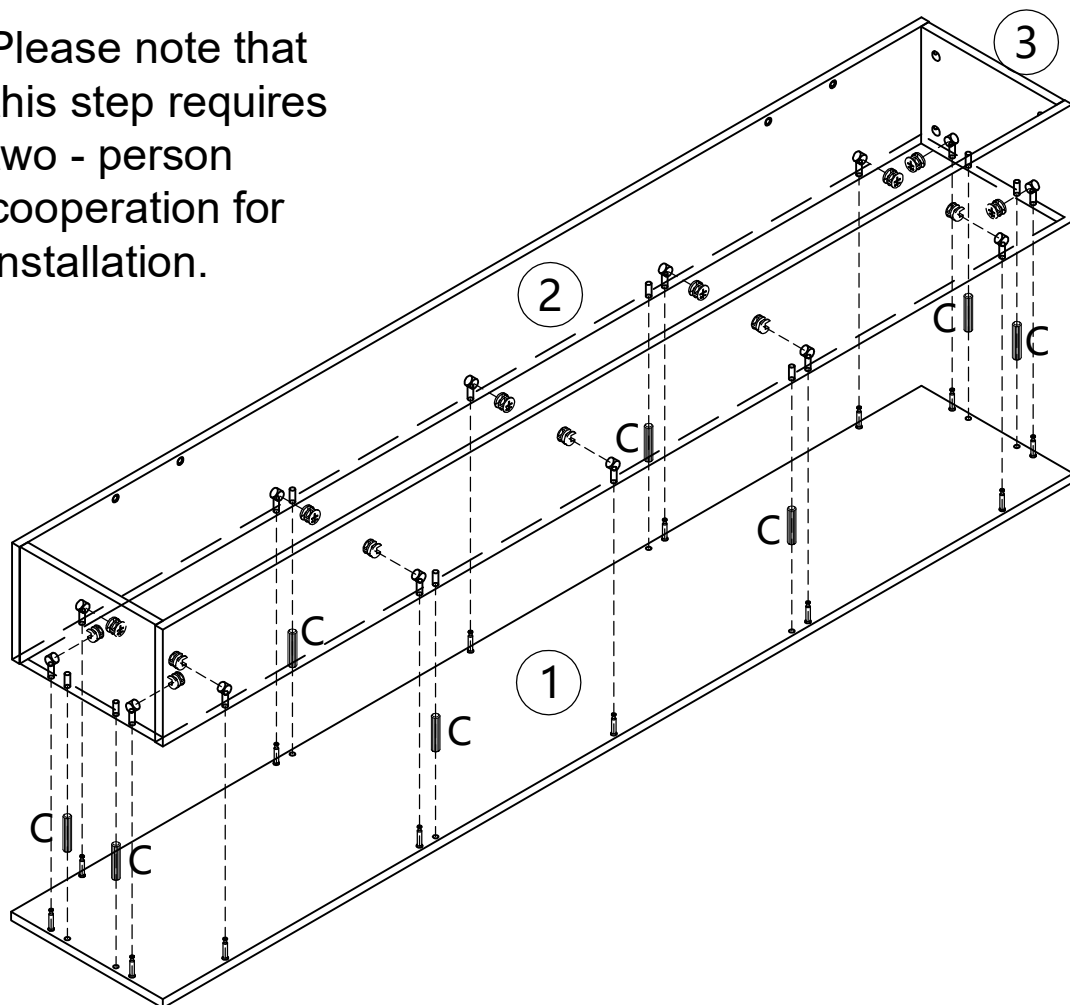

Step 4.

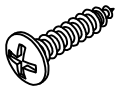

G x 8

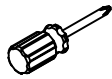

K x 1

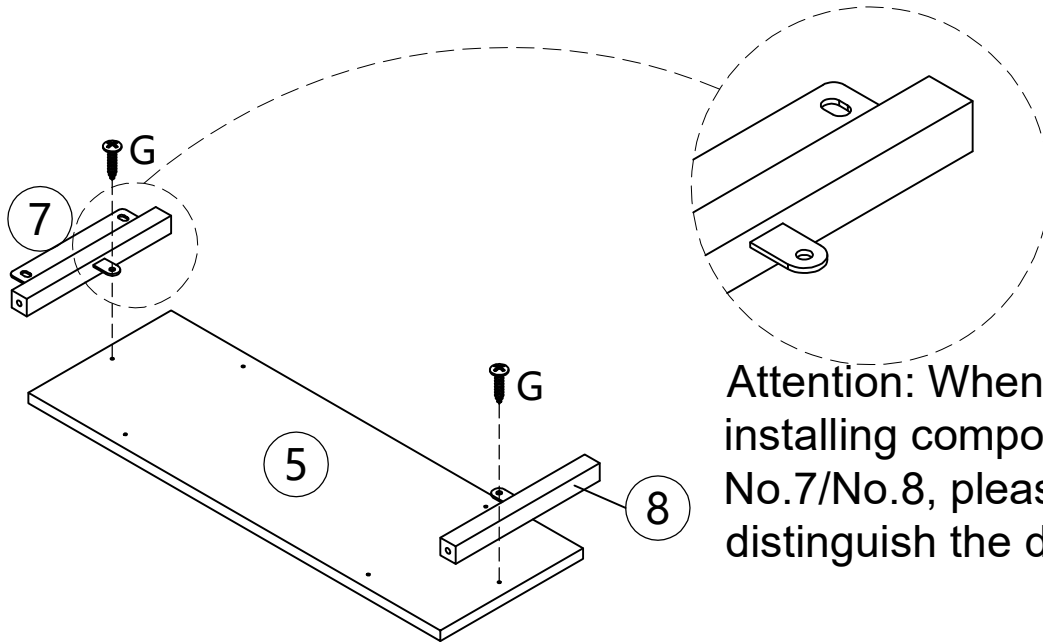

Attention: When installing component No.7/No.8, please distinguish the direction.

x4

Step 5.

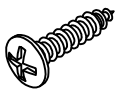

G x 24

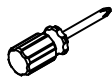

K x 1

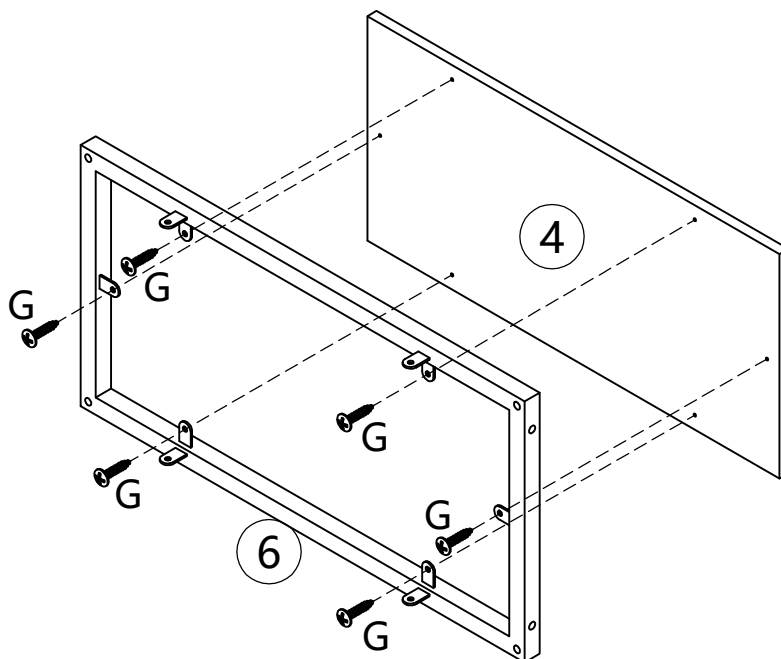

x4

Step 6.

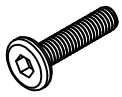

E x8

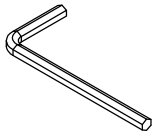

F x1

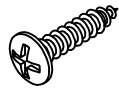

G x 8

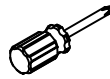

K x1

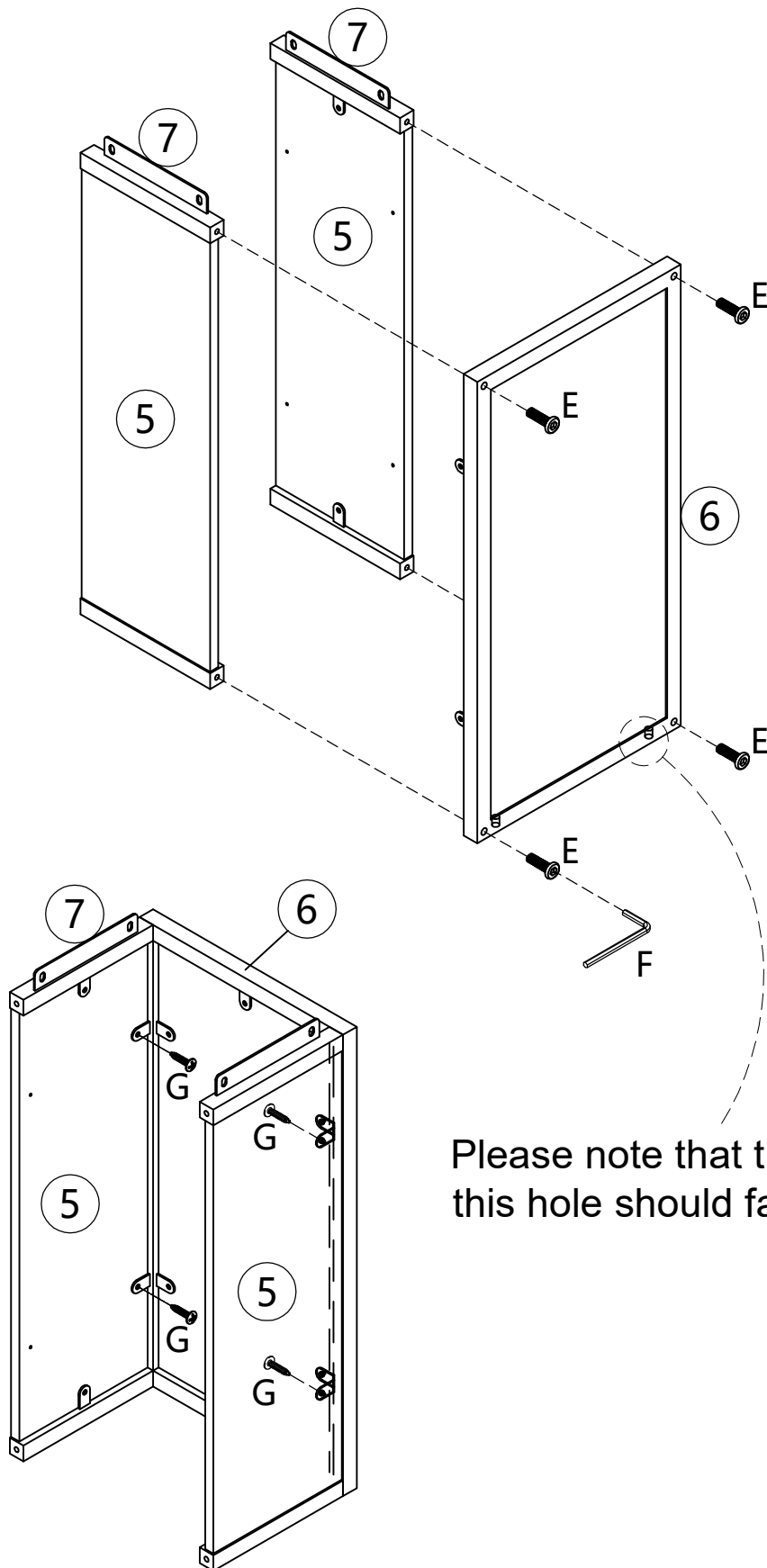

Please note that the direction of this hole should face downward.

x2

Step 7.

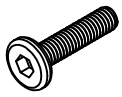

E x8

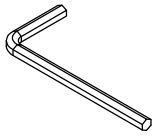

F x1

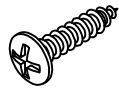

G x 8

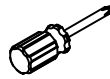

K x1

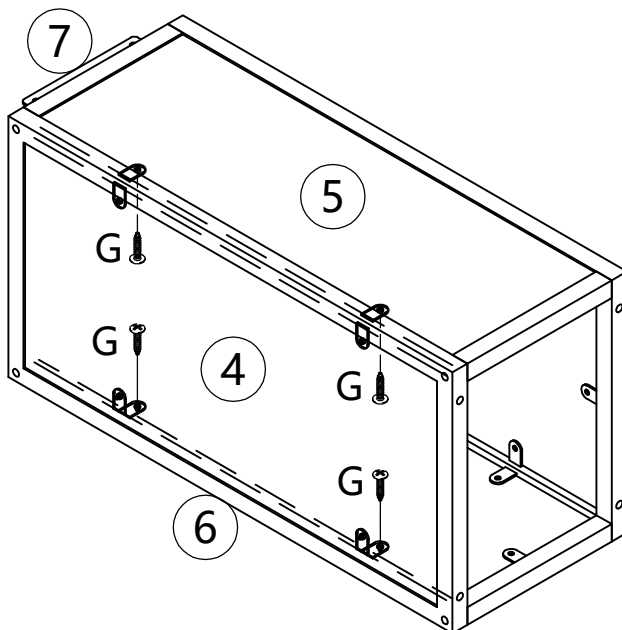
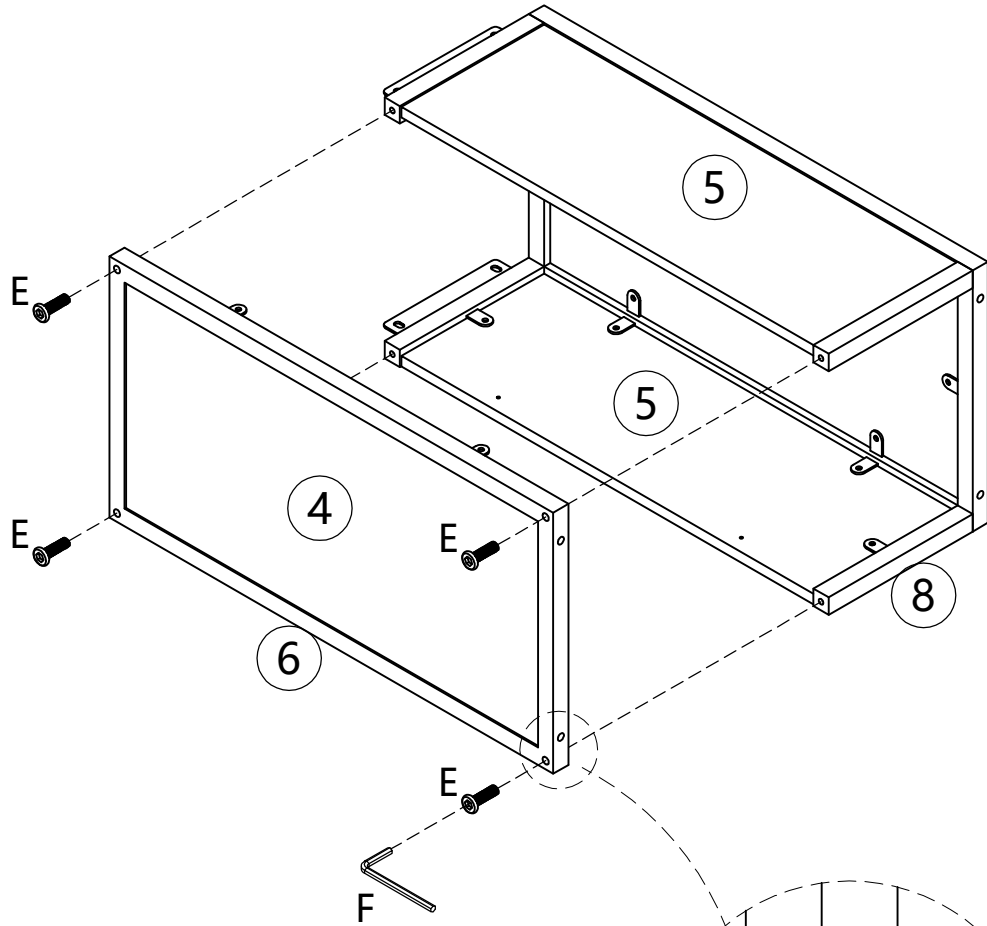

Step 8.

2-Person
Assembly

Please note that this step requires two -
person cooperation for installation.

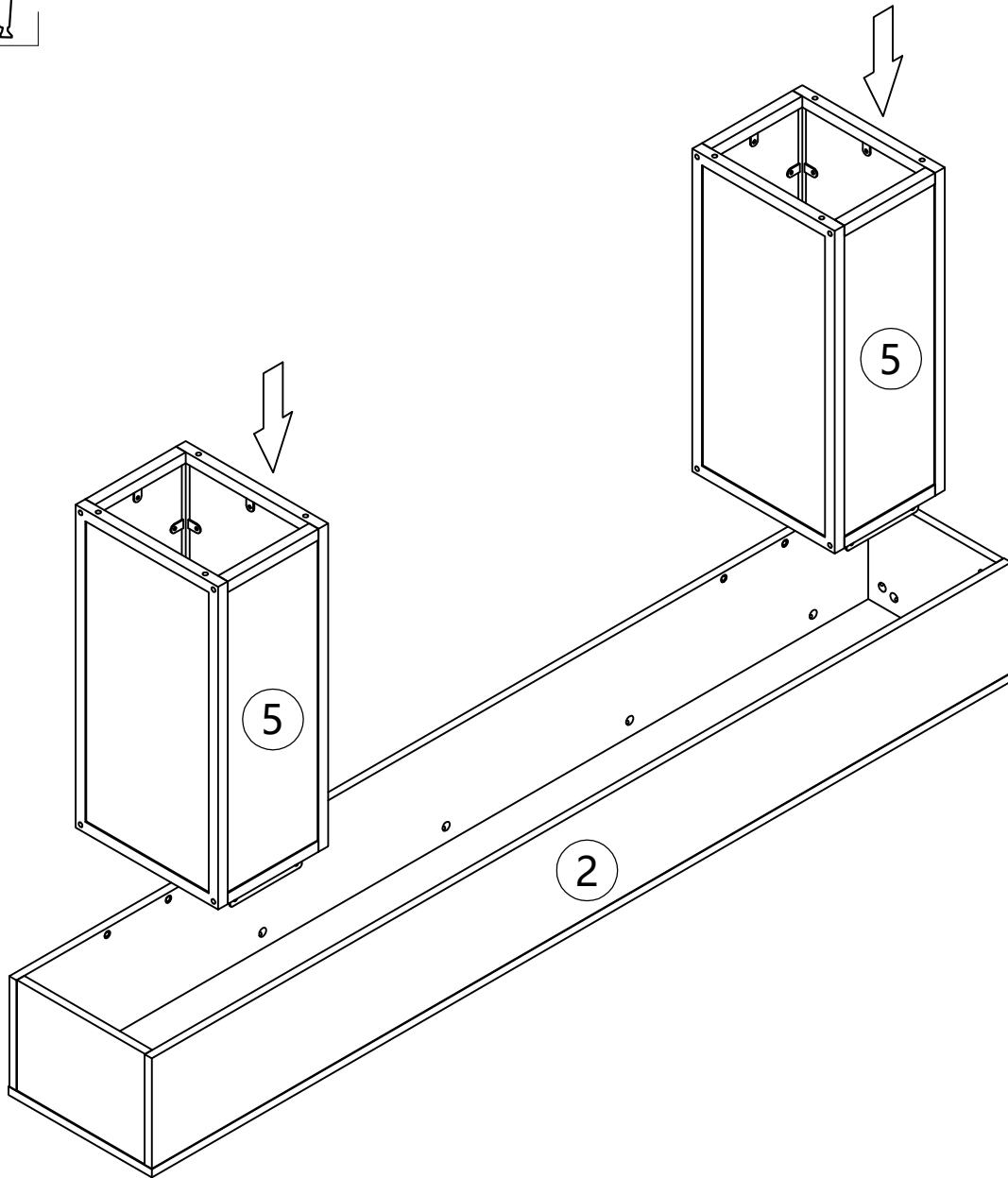
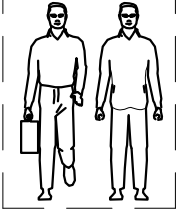

Step 9.



D x 8

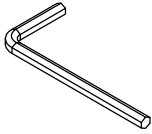

F x 1

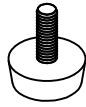

I x 8

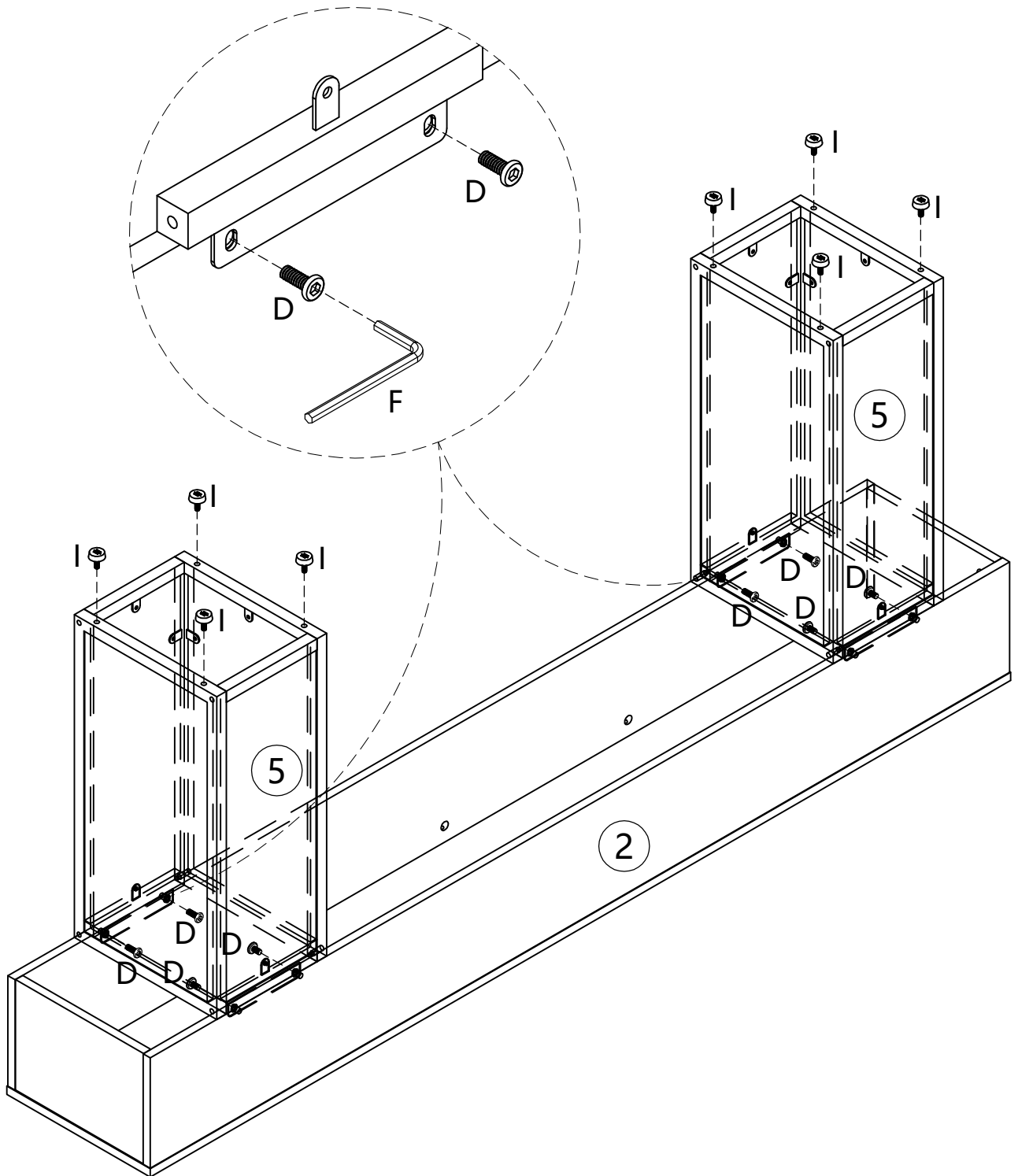

Step 10.



H x4

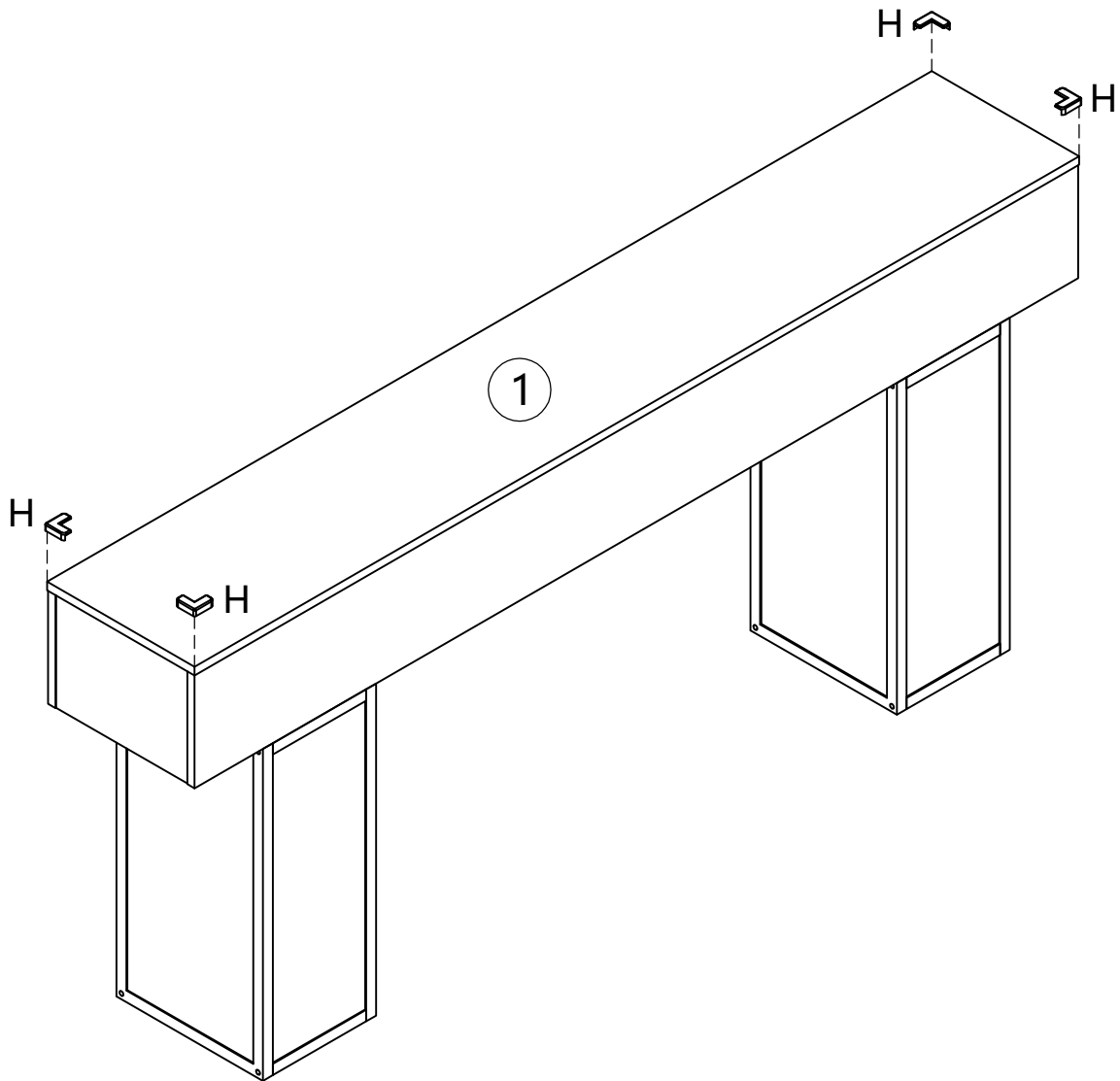

Step 11.

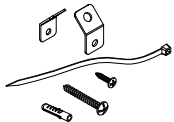

J x2

R x1

